

Silicon PNP Power Transistors

2SA1010

DESCRIPTION

- With TO-220 package
- Complement to type 2SC2334
- Low collector saturation voltage
- Fast switching speed

APPLICATIONS

- Switching regulators
- DC/DC converters
- High frequency power amplifiers

PINNING

PIN	DESCRIPTION
1	Emitter
2	Collector;connected to mounting base
3	Base

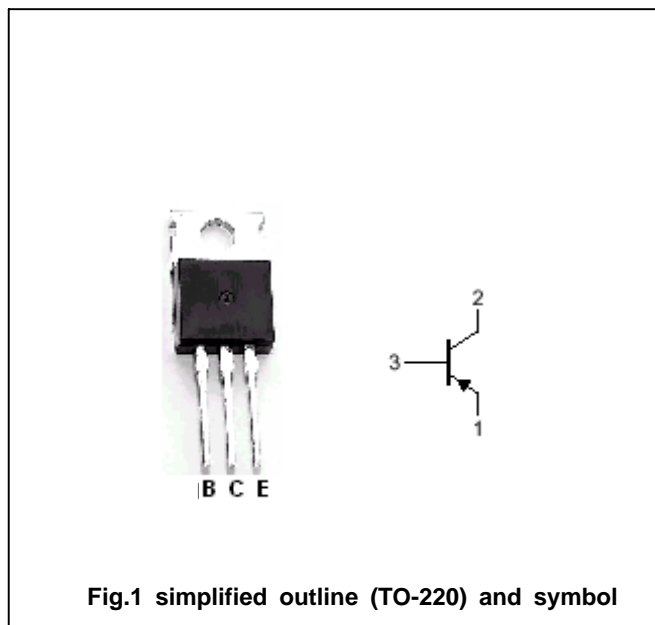

Absolute maximum ratings(Ta=25)

SYMBOL	PARAMETER	CONDITIONS	VALUE	UNIT
V_{CBO}	Collector-base voltage	Open emitter	-100	V
V_{CEO}	Collector-emitter voltage	Open base	-100	V
V_{EBO}	Emitter-base voltage	Open collector	-7	V
I_C	Collector current		-7	A
I_{CM}	Collector current-Peak		-15	A
I_B	Base current		-3.5	A
P_T	Total power dissipation	$T_a=25$	1.5	W
		$T_C=25$	40	
T_j	Junction temperature		150	
T_{stg}	Storage temperature		-55~150	

Silicon PNP Power Transistors

2SA1010

CHARACTERISTICS

T_j=25 unless otherwise specified

SYMBOL	PARAMETER	CONDITIONS	MIN	TYP.	MAX	UNIT
V _{CE0(SUS)}	Collector-emitter sustaining voltage	I _C =-5.0A, I _B =-0.5A, L=1mH	-100			V
V _{CEsat}	Collector-emitter saturation voltage	I _C =-5A; I _B =-0.5A			-0.6	V
V _{BEsat}	Base-emitter saturation voltage	I _C =-5A; I _B =-0.5A			-1.5	V
I _{CBO}	Collector cut-off current	V _{CB} =-100V; I _E =0			-10	μA
I _{EBO}	Emitter cut-off current	V _{EB} =-5V; I _C =0			-10	μA
h _{FE-1}	DC current gain	I _C =-0.5A; V _{CE} =-5V	40		200	
h _{FE-2}	DC current gain	I _C =-3A; V _{CE} =-5V	40		200	
h _{FE-3}	DC current gain	I _C =-5A; V _{CE} =-5V	20			

Switching times resistive load

t _{on}	Turn-on time	I _C =-5.0A I _{B1} =- I _{B2} =-0.5A R _L =10 ; V _{CC} 50V			0.5	μs
t _s	Storage time				1.5	μs
t _f	Fall time				0.5	μs

◆ h_{FE-2} Classifications

M	L	K
40-80	60-120	100-200

Silicon PNP Power Transistors

2SA1010

PACKAGE OUTLINE

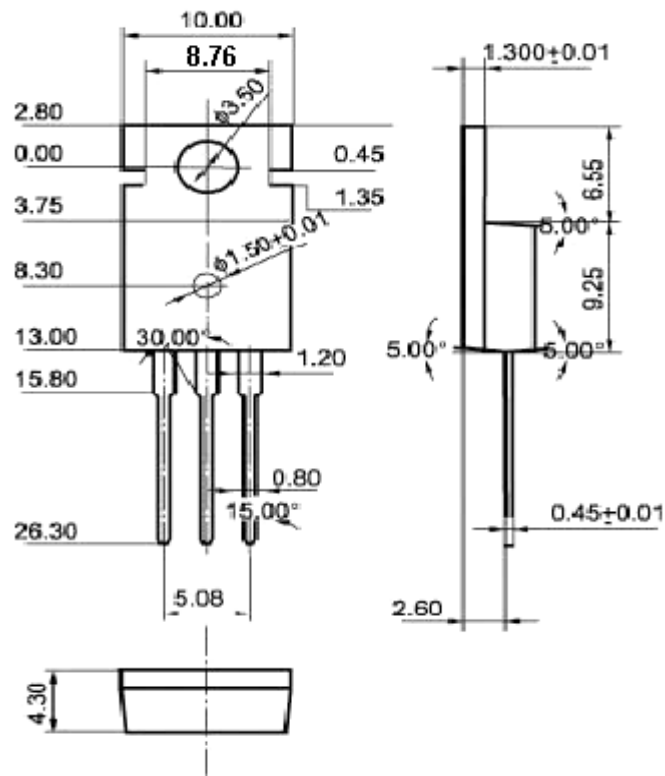

Fig.2 Outline dimensions(unindicated tolerance: ± 0.10 mm)

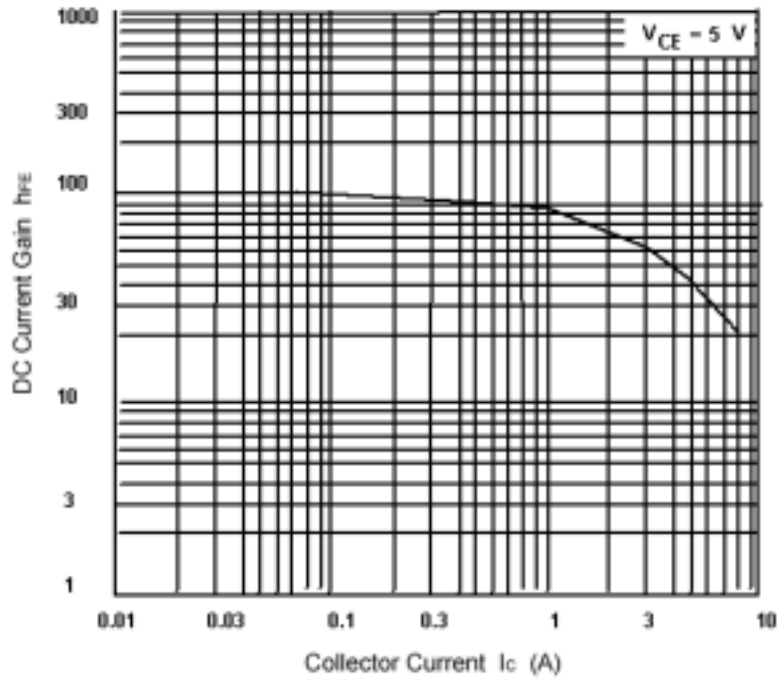

Fig.3 DC current Gain

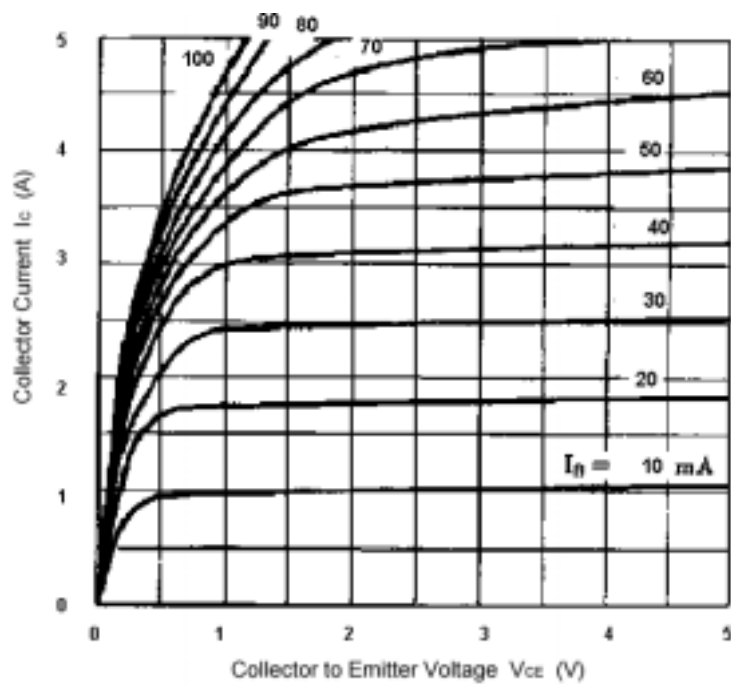

Fig.4 Static Characteristic

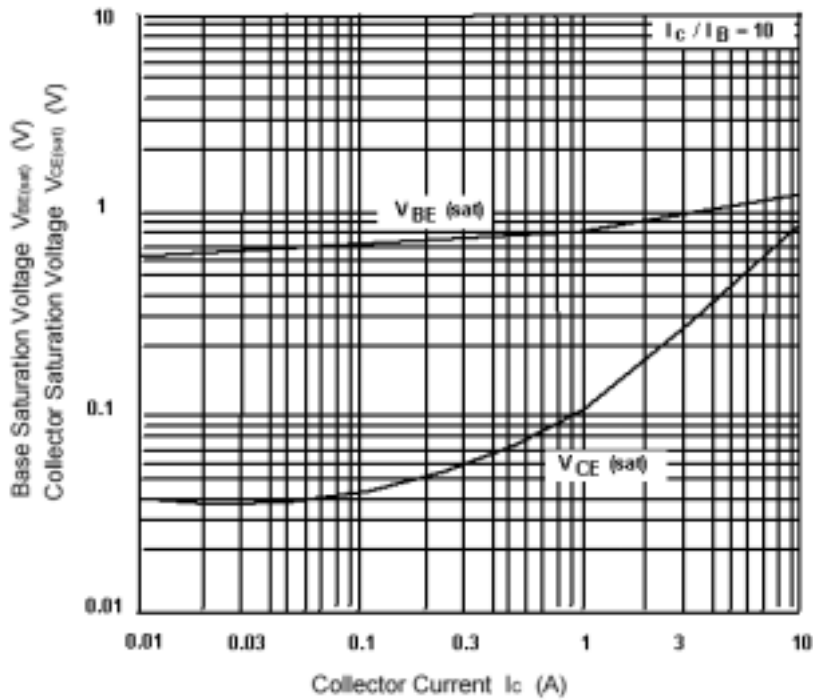

Fig.5 Base-Emitter Saturation Voltage
Collector-Emitter Saturation Voltage

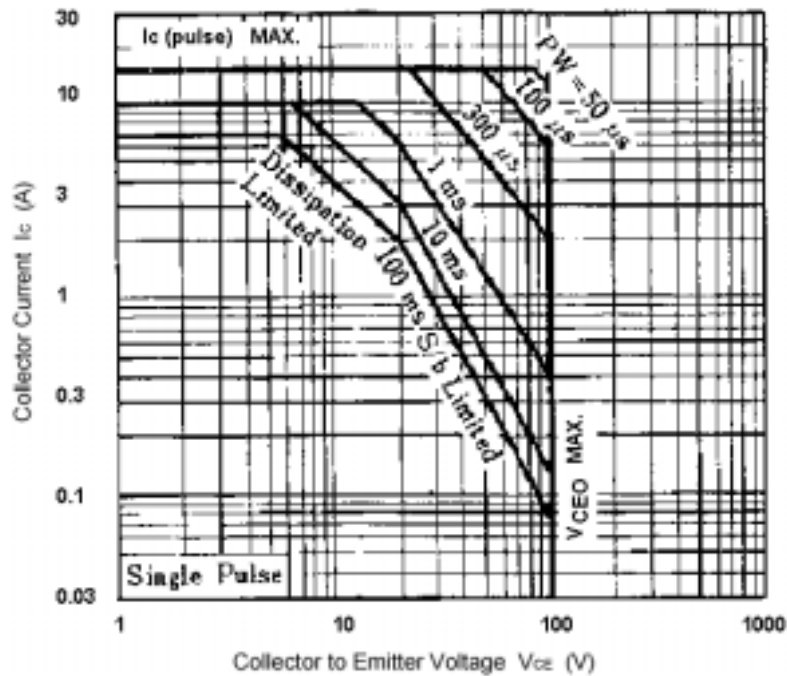

Fig.6 Safe Operating Area