



# 6W Quad Channel DC/DC LED Driver with Diagnostics



## FEATURES

- Four LED Channels with tight current matching
- Integrated DC/DC Boost converter
- Up to 6 W LED Total Output Power
- Up to 92% Efficiency
- Low Dropout LED Channels (500 mV at 175 mA)
- High Frequency PWM interface (up to 2 kHz)
- Adjustable Short/Open LED Detection
- Programmable LED Channel current
- Adjustable LED Channel voltage
- Thermal shutdown protection
- RoHS-compliant 16-lead TQFN 4 x 4 mm and TSSOP packages

## APPLICATIONS

- LCD Backlight Lighting
- Automotive and General Purpose Lighting

## ORDERING INFORMATION

Part Number	Package	Quantity per Reel	Package Marking
CAT4106HV4-GT2	TQFN-16 <sup>(1)</sup>	2,000	CDAL
CAT4106YP-T2	TSSOP-16 <sup>(2)</sup>	2,000	4106Y

Notes: (1) NiPdAu Plated Finish (RoHS-compliant)  
 (2) Matte-Tin Plated Finish (RoHS-compliant).

## PIN CONFIGURATION

TSSOP 16-Lead (Top View)

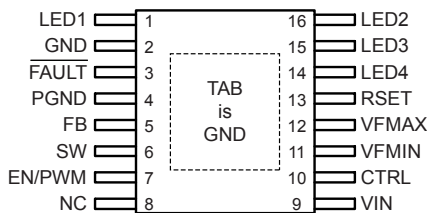

TQFN 16-Lead (Top View)

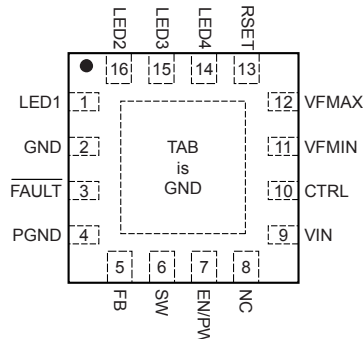

## DESCRIPTION

The CAT4106 is an integrated multi-channel LED driver and high power DC/DC converter suitable for powering backlighting applications up to a total of 6 watts. Up to four matched LED strings can be accurately programmed with uniform drive current set by a single external resistor. Each output channel is suitable for LED string voltages of up to 36 V. The driver automatically adjusts the output voltage to drive the highest forward voltage string with the minimum headroom voltage maximizing the efficiency.

High resolution dimming control is achieved by the EN/PWM logic pin which supports multiple frequencies. This ensures precise PWM dimming control while the device remains fully biased. In addition, when held at logic low, the device to enter a full shutdown “zero” current mode.

External programming resistors set the minimum and maximum voltage limits for the acceptable “window of operation” for LED strings. Any channel which fails to regulate within the window (Open or Short LED) is detected and flagged on the FAULT logic output (active low, open-drain).

The device is available in a 16-lead TQFN 4 mm x 4 mm and TSSOP with exposed pad packages.

For Ordering Information details, see page 16.

## TYPICAL APPLICATION CIRCUIT

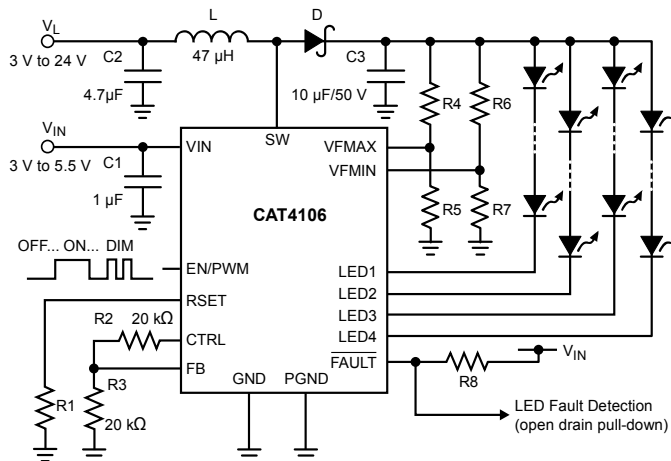

**ABSOLUTE MAXIMUM RATINGS<sup>(1)</sup>**

Parameters	Ratings	Units
VIN, RSET, EN/PWM, CTRL, FB, FAULT	-0.3V to 6	V
VFMIN, VFMAX	-0.3V to 6	V
LED1, LED2, LED3, LED4	-0.3V to 25	V
SW (internally clamped to 40 V)	50	V
Storage Temperature Range	-65 to +160	°C
Junction Temperature Range	-40 to +150	°C
Lead Temperature	300	°C

**RECOMMENDED OPERATING CONDITIONS**

Parameter	Range	Units
VIN	3.0 to 5.5	V
Inductor Drive Voltage	3.0 to 24	V
LED String Forward Voltage per channel	up to 36	V
Ambient Temperature Range	-40 to +85	°C
I <sub>LED</sub> per LED pin	10 to 175	mA

Typical application circuit with external components is shown on page 1.

**RECOMMENDED EN/PWM TIMING**

For  $3.0 \leq V_{IN} \leq 5.5V$ , over full ambient temperature range -40 to +85°C.

Symbol	Name	Conditions	Min	Typ	Max	Units
T <sub>LEDCURSETUP</sub>	LED setup time from shutdown		10	40	100	µs
T <sub>LO</sub>	EN/PWM low time		0.2		2000	µs
T <sub>HI</sub>	EN/PWM high time		0.2			µs
T <sub>PWRDWN</sub>	EN/PWM low time to shutdown delay				8	ms
T <sub>LEDSET</sub>	LED current settling time	I <sub>LED</sub> = 100 mA		0.2		µs

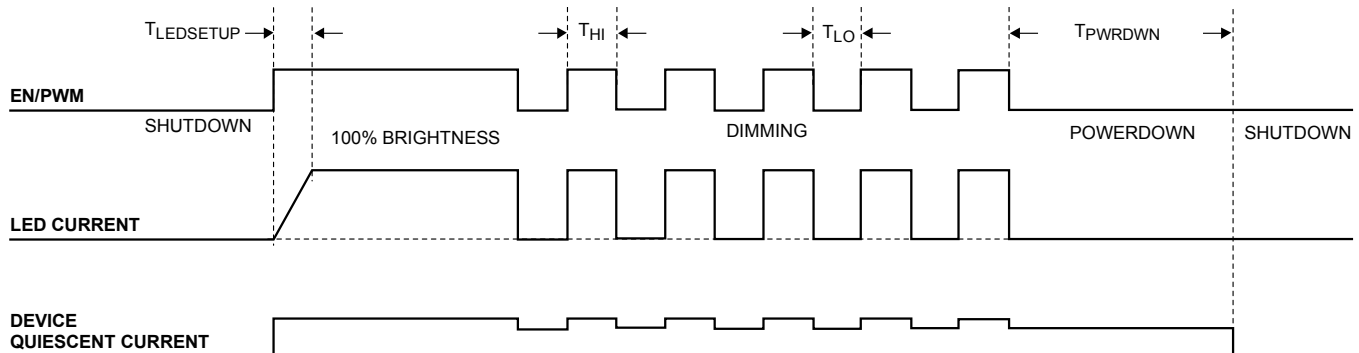

**Figure 3. CAT4106 EN/PWM Timing**

**Notes:**

- (1) Stresses above those listed under "Absolute Maximum Ratings" may cause permanent damage to the device. These are stress ratings only, and functional operation of the device at these or any other conditions outside of those listed in the operational sections of this specification is not implied. Exposure to any absolute maximum rating for extended periods may affect device performance and reliability.

**ELECTRICAL OPERATING CHARACTERISTICS**

V<sub>IN</sub> = 5 V, V<sub>L</sub> (inductor drive voltage) = 12 V, T<sub>AMB</sub> = 25°C (over recommended operating conditions unless specified otherwise)

Symbol	Description	Conditions	Min	Typ	Max	Units
I <sub>Q</sub>	V <sub>IN</sub> Operating Current	Switching (I <sub>LED</sub> = 30 mA) Not Switching (I <sub>LED</sub> = 30 mA) Switching (I <sub>LED</sub> = 60 mA) Not Switching (I <sub>LED</sub> = 60 mA)		2.5 2.0 3.4 2.9	3.5 3.0 4.4 3.9	mA
I <sub>SD</sub>	V <sub>IN</sub> input shutdown Current	V <sub>EN</sub> = 0V			1	μA
V <sub>IH</sub> V <sub>IL</sub> R <sub>EN</sub>	<b>EN/PWM</b> Logic High Threshold Logic Low Threshold Internal Pull-Down Resistor	Device Enable Level Disable/PWM Level	0.4 100	0.8 0.7 200	1.3 300	V V kΩ
V <sub>UVLO</sub>	Undervoltage lockout (UVLO)	V <sub>IN</sub> pin voltage		2.0		V
T <sub>SD</sub>	Thermal Shutdown Threshold			150		°C
T <sub>HYS</sub>	Thermal Hysteresis			20		°C
V <sub>RSET</sub>	RSET regulation voltage	10 μA < I <sub>RSET</sub> < 2 mA.	1.17	1.20	1.23	V
I <sub>LED</sub> /I <sub>RSET</sub>	RSET to LED Current gain ratio	30 mA LED current		100		
V <sub>DO</sub>	LED Channel Dropout Voltage	I <sub>LED</sub> = 175 mA		0.5		V
ΔI <sub>LED</sub>	LED Channel Matching	0.5 V < V <sub>LED</sub> < 5 V	-5	±1	+5	%
I <sub>LED-OFF</sub>	LED Channel leakage	Channel is Off			1	μA
V <sub>VFMAX</sub>	O/C Detect voltage threshold		1.15	1.20	1.25	V
V <sub>VFMIN</sub>	S/C Detect voltage threshold		1.15	1.20	1.25	V
V <sub>CTRL</sub> I <sub>CTRL</sub>	CTRL pin voltage accuracy CTRL pin maximum load	Offset to Lowest LED output	- 0.1 25	0	+ 0.1	V μA
I <sub>FAULT</sub>	Pull-down Drive Current Open Drain Leakage Current	<u>FAULT</u> is Active (0.1 V bias) <u>FAULT</u> is Inactive	1	2	1	mA μA
V <sub>FB</sub> I <sub>FB</sub>	FB Pin control voltage FB pin input leakage current	Normal switching mode regulation	285	300	315 1	mV μA
F <sub>SW</sub> I <sub>SWMAX</sub> R <sub>SW</sub> DC <sub>MAX</sub> DC <sub>MIN</sub> I <sub>SWLEAK</sub> OVP <sub>SW</sub>	<b>SW Pin</b> Switching Frequency Switch Pin Current Limit Switch Pin On-resistance Maximum Duty Cycle Minimum Duty Cycle Switch Leakage Current Over Voltage Protection Detect	I <sub>SW</sub> = 500 mA Prior to Current Limiting Prior to Pulse-Skipping V <sub>SW</sub> = 20 V Enters Low Power mode	0.7 0.8	1.0 1.0 1.0 96 5	1.3	MHz A Ω % % μA V

**TYPICAL ELECTRICAL OPERATING CHARACTERISTICS**

V<sub>IN</sub> = 5 V, V<sub>L</sub> = 12 V, T<sub>AMB</sub> = 25°C, typical application circuit unless otherwise specified.

**Quiescent Current vs. RSET Current**

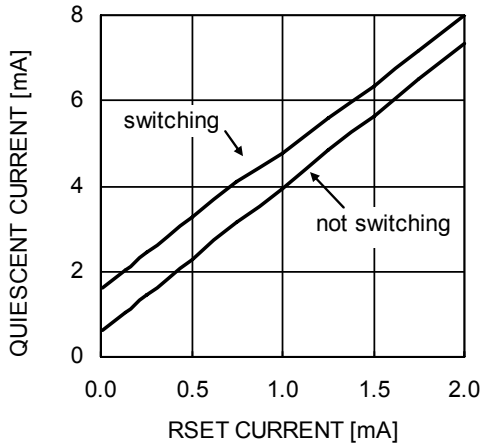

**RSET Voltage vs. VIN Supply**

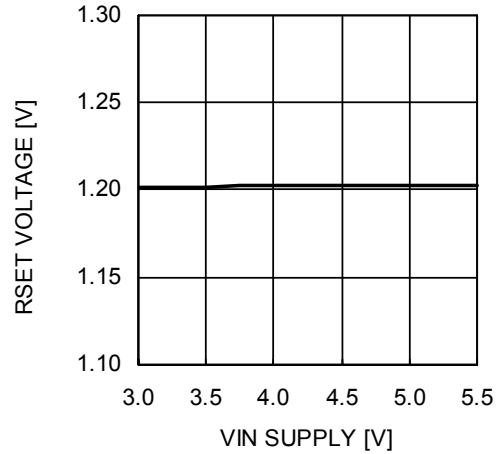

**RSET Voltage vs. Temperature**

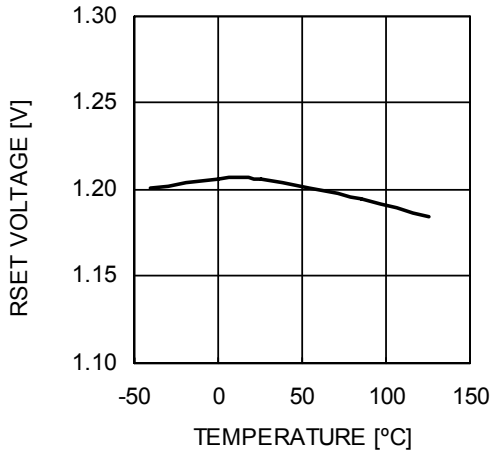

**I<sub>LED</sub>/I<sub>RSET</sub> Gain vs. LED Current**

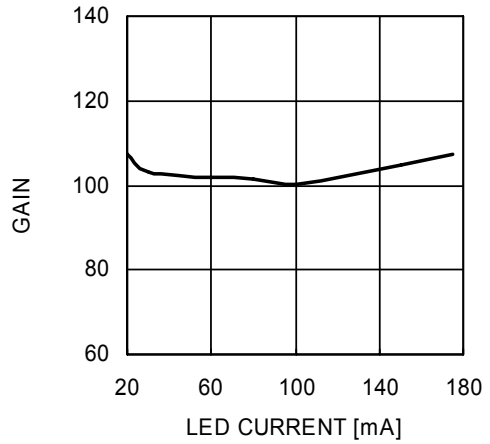

**LED Channel Current vs. LED Pin Voltage**

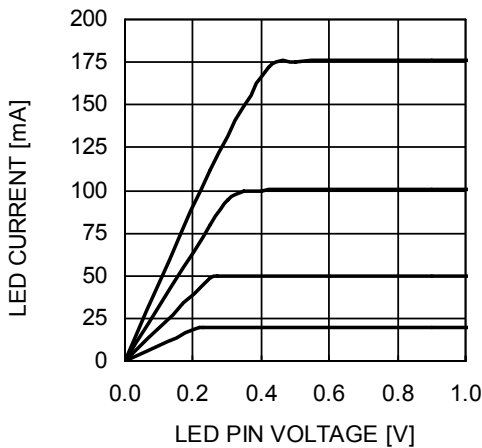

**LED Channel Current vs. VIN Supply**

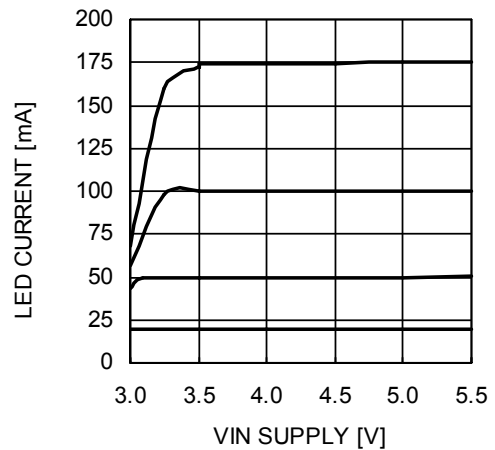

**TYPICAL ELECTRICAL OPERATING CHARACTERISTICS**

VIN = 5 V, VL = 12 V, T<sub>AMB</sub> = 25°C, typical application circuit unless otherwise specified.

**LED Channel Voltage vs. VIN Supply**

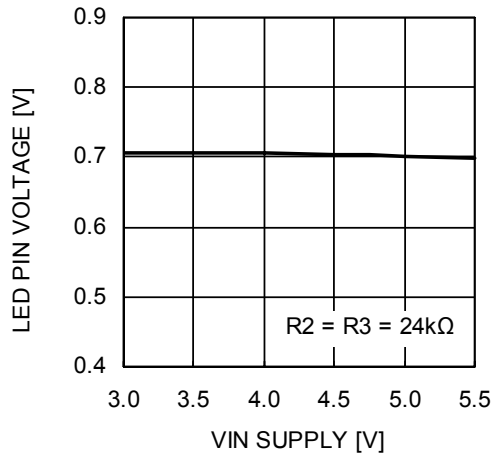

**FAULT Drive R<sub>DS(on)</sub> vs. VIN Supply**

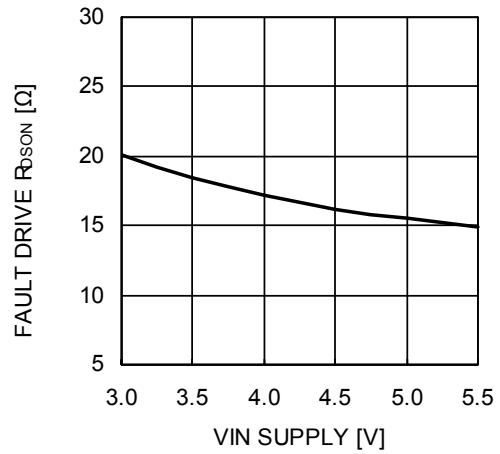

**Switch Resistance vs. VIN Supply**

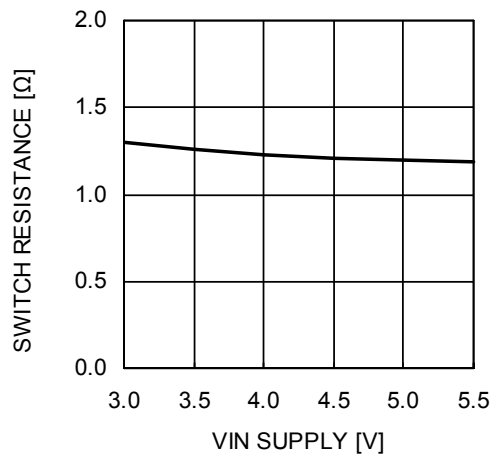

**Switching Frequency vs. VIN Supply**

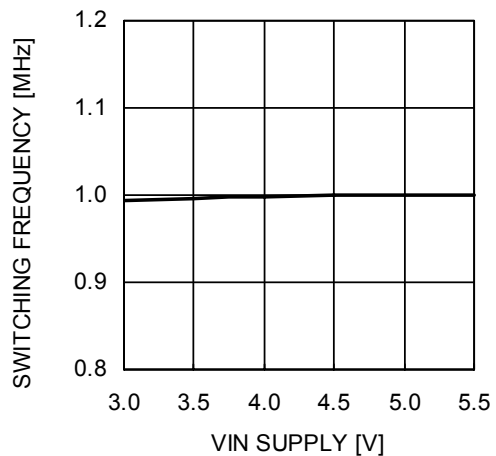

**Switching Current Limit vs. VIN Supply**

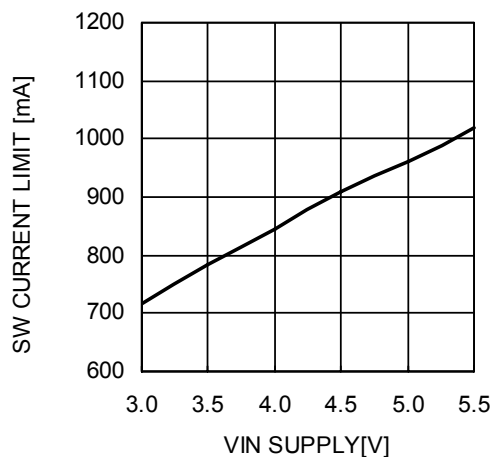

**Powerdown Delay vs. VIN Supply**

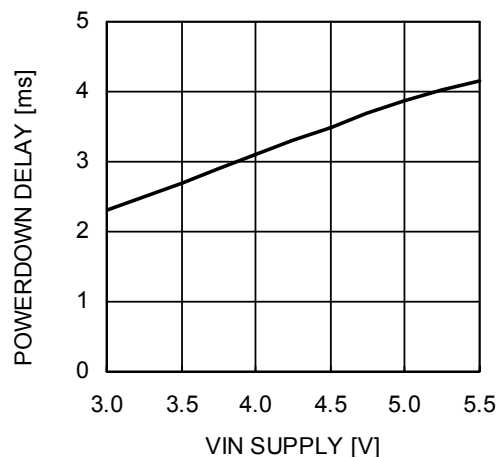

**TYPICAL ELECTRICAL OPERATING CHARACTERISTICS**

VIN = 5 V, VL = 12 V, TAMB = 25°C, typical application circuit unless otherwise specified.

**EN/PWM Threshold vs. VIN Supply**

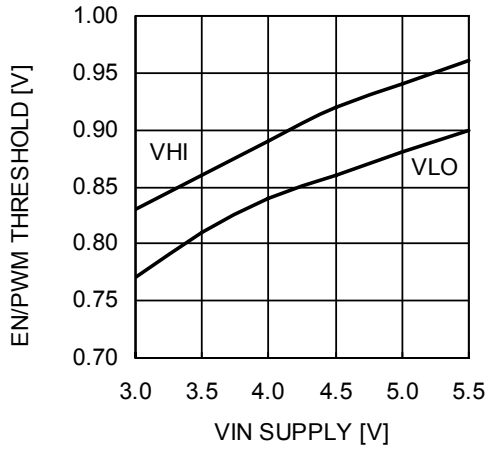

**PWM Duty Cycle vs. LED Current**

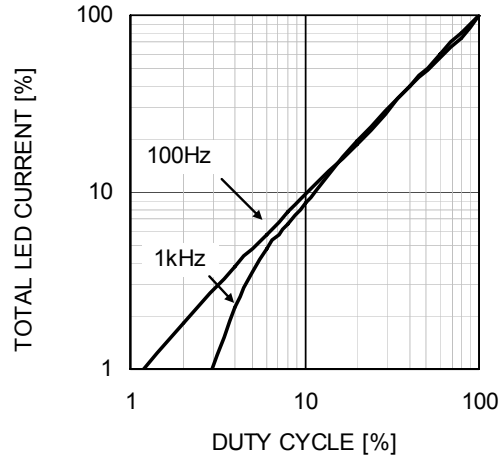

**PWM Dimming 100 Hz**

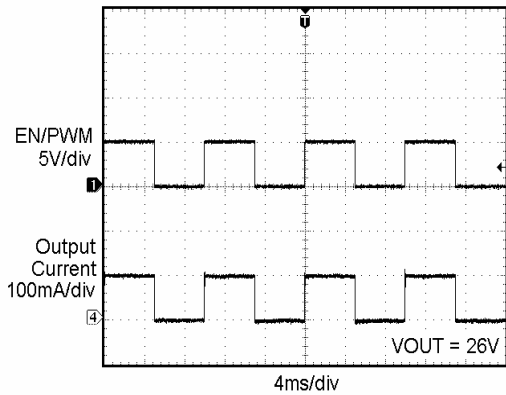

**PWM Dimming 1 kHz**

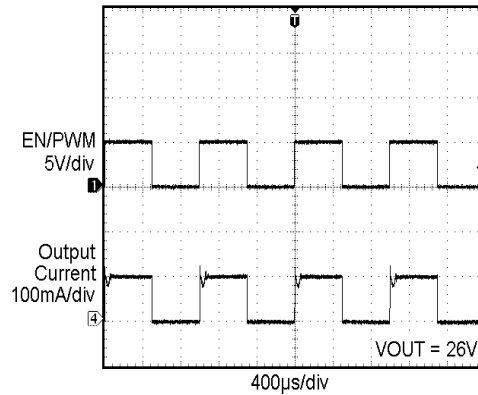

**Power-Up 4 x 10 LEDs, 50 mA per Channel**

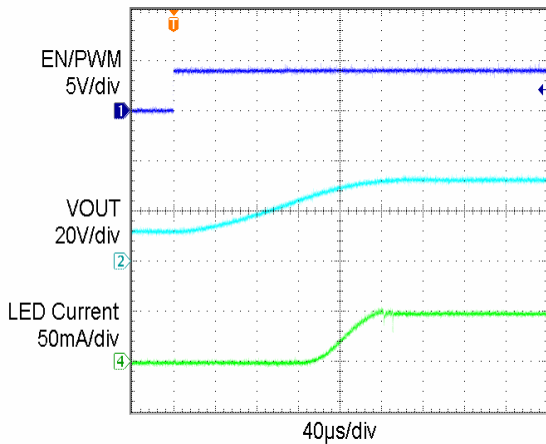

**Maximum LED Current vs. VL Supply**

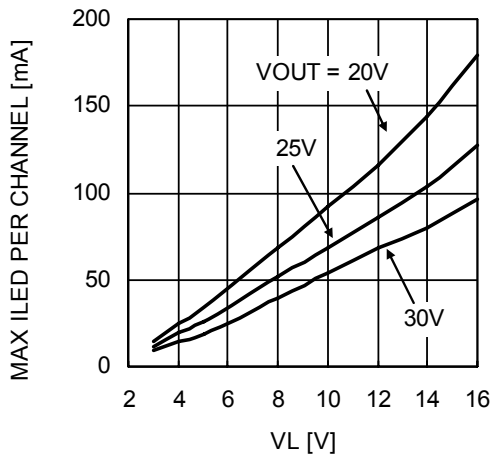

**TYPICAL ELECTRICAL OPERATING CHARACTERISTICS**

VIN = 5 V, VL = 12 V, 20mA per channel (80mA total output current), T<sub>AMB</sub> = 25°C, typical application circuit unless otherwise specified.

**Efficiency vs. VIN (VIN = VL)**

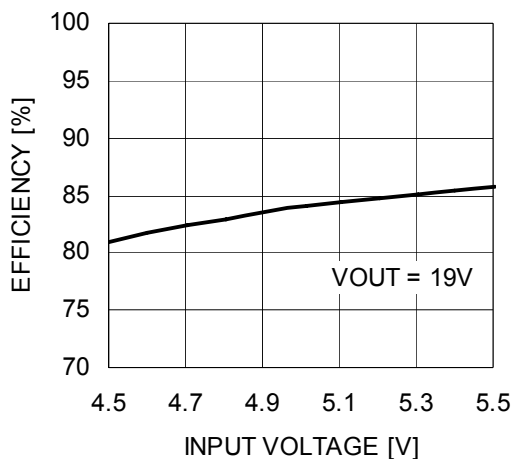

**Efficiency vs. VL (VIN = 5V)**

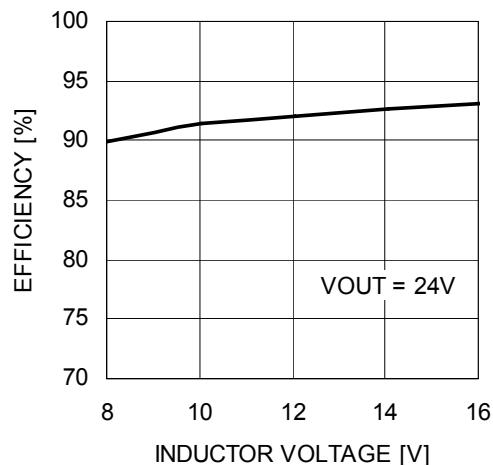

**Efficiency vs. Output Current (9-LED string)**

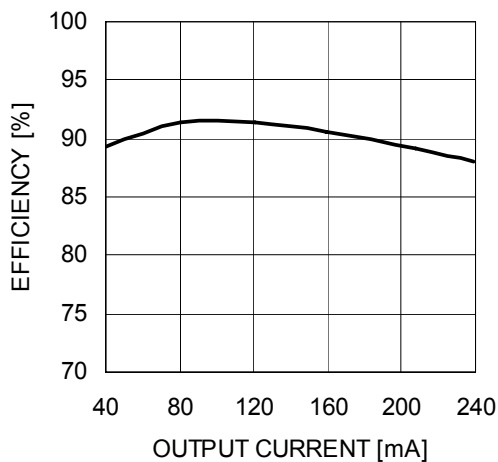

## PIN DESCRIPTION

Name	TQFN-16 TSSOP-16	Function
LED1	1	LED1 cathode terminal
GND	2	Signal Ground reference
$\overline{\text{FAULT}}$	3	Open/Short LED Fault detection output (active-low)
PGND	4	Power Ground Reference (DC/DC Power Switch)
FB	5	Feedback reference (300 mV) for setting LED channel operating voltage
SW	6	Internal power FET switch drain connection
EN/PWM	7	Device Enable (active high) and PWM control input
N.C	8	Not connected
VIN	9	Supply voltage for the device
CTRL	10	LED channel operating voltage (lowest of all 4 channels)
VFMIN	11	Comparator input for setting the LED string short-circuit voltage limit
VFMAX	12	Comparator input for setting the LED string open-circuit voltage limit
RSET	13	RSET resistor pin for setting the LED channel operating current
LED3	14	LED3 cathode terminal
LED3	15	LED3 cathode terminal
LED4	16	LED4 cathode terminal
TAB	TAB	Thermal pad (connect to GND and PGND)

## PIN DESCRIPTIONS

**VIN** is the supply pin for the device. The supply input current needed for normal operation is approximately 2 mA plus 3 times  $I_{\text{RSET}}$  pin current. During intervals of PWM dimming, or whenever the converter is not switching, the supply current will decrease by around 1 mA. The voltage applied at VIN should be kept between 3 V and 5.5 V. A small ceramic bypass capacitor of 0.1  $\mu\text{F}$  or greater is recommended to be in close proximity to the VIN pin.

**EN/PWM** is the device Enable and PWM dimming control input for all LED channels. Guaranteed levels of logic high and logic low are set at 1.3 V and 0.4 V respectively. During normal PWM dimming, the entire device remains fully biased and only the LED channels are pulsed on/off. The device will only enter zero current shutdown mode after the EN/PWM is held low for at least 5 ms typically. This pin has an internal pull-down resistor of 200 k $\Omega$ .

**RSET** is the voltage regulated control pin for sensing the desired programming current level to be applied on all LED channels. During normal operation, the RSET pin is kept at 1.2 V and accurately monitors the current level in the externally applied R1 resistor. The current transfer ratio from RSET pin current to LED pin current is 100.

**LED1 to LED4** provide the regulated current source for driving each of the LED strings with a tightly matched constant current. To ensure optimal performance, the bias voltage on the LED channels should be set at a nominal 0.6 V or higher. Each channel is capable of driving a current up to 175 mA. All channels immediately enter a high impedance mode whenever the EN/PWM is taken LOW.

**CTRL** pin is a multiplexer output which selects the lowest operating voltage appearing on any of the four LED output drive channels. This control signal represents the cathode terminal voltage of the LED string with greatest forward voltage ( $V_F$ ). An external resistor network from CTRL to FB can be used to set the lowest operating voltage of each channel. External current loading of the CTRL pin is recommended to be less than 25  $\mu\text{A}$ .

**FB** is the voltage feedback control pin for the internal high power DC/DC converter. This pin has a high impedance input and its voltage remains accurately regulated to 0.3 V during normal steady state operation



**SW** pin is the drain terminal of the high voltage CMOS power switch which has a typical on-resistance of 1  $\Omega$  and is current limited to 1 A typically. An overvoltage protection circuit places the device in a soft-clamping low power mode if the voltage transients exceed 40 V.

**VFMIN** pin uses a pair of external resistors (R6 & R7) to program the worst case, minimum LED string forward voltage ( $V_{FMIN}$ ) expected in the specific application. If, during power-up, any LED string enters full regulation before this programmed level is reached ( $V_{FMIN}$  pin voltage < 1.2 V), the string will be considered to contain LEDs which are short-circuit and a fault condition will be flagged. The VFMIN input circuitry consists of a comparator referenced to 1.2 V. A typical value for resistor R7 is around 20 k $\Omega$ . R6 can be calculated as follows:

$$R6 = R7 \times \left( \frac{V_{FMIN}}{1.2 V} - 1 \right)$$

If this detection feature is not needed, the VFMIN pin must be tied to ground.

**VFMAX** pin uses a pair of external resistors (R4 & R5) to program the worst case, maximum LED string forward voltage ( $V_{FMAX}$ ) expected in the specific application. If any LED string fails to become regulated before the programmed voltage is reached, the string will be considered to contain LEDs which are open-circuit and a fault condition will be flagged. When an open-circuit is flagged, the individual channel that causes the open-circuit is internally flagged and subsequently ignored. In the event that all channels are detected as being Open-LED, the Output Voltage (top LED Anode) will stabilize at the

VFMAX programmed voltage. The VFMAX input circuitry consists of a comparator referenced to 1.2 V.

A typical value for resistor R5 is 20 k $\Omega$ . R4 can be calculated as follows:

$$R4 = R5 \times \left( \frac{V_{FMAX}}{1.2 V} - 1 \right)$$

If this detection feature is not needed, the VFMAX pin must be tied to ground.

**FAULT** is an open-drain, active-low, logic signal which becomes active during an LED short-circuit or open-circuit condition. The pin must be connected to a pull-up resistor of around 100 k $\Omega$  tied to VIN. The drive pull-down resistance (when active) is typically less than 100  $\Omega$ . The diagnostic sequence used to determine a fault condition is initiated when the device is first enabled.

**PGND** pin is the source connection terminal of the high voltage CMOS power switch in the DC/DC converter. The inductor supply bypass capacitor should be connected in close proximity to the PGND pin. The return current from PGND should be connected to the PCB ground plane.

**GND** is the ground reference pin for the device. All analog control voltages are referenced to this pin. In addition, all LED drive currents are conducted through the GND pin.

**TAB** is the thermal pad connection of the package and should be connected to PCB ground plane.

**BLOCK DIAGRAM**

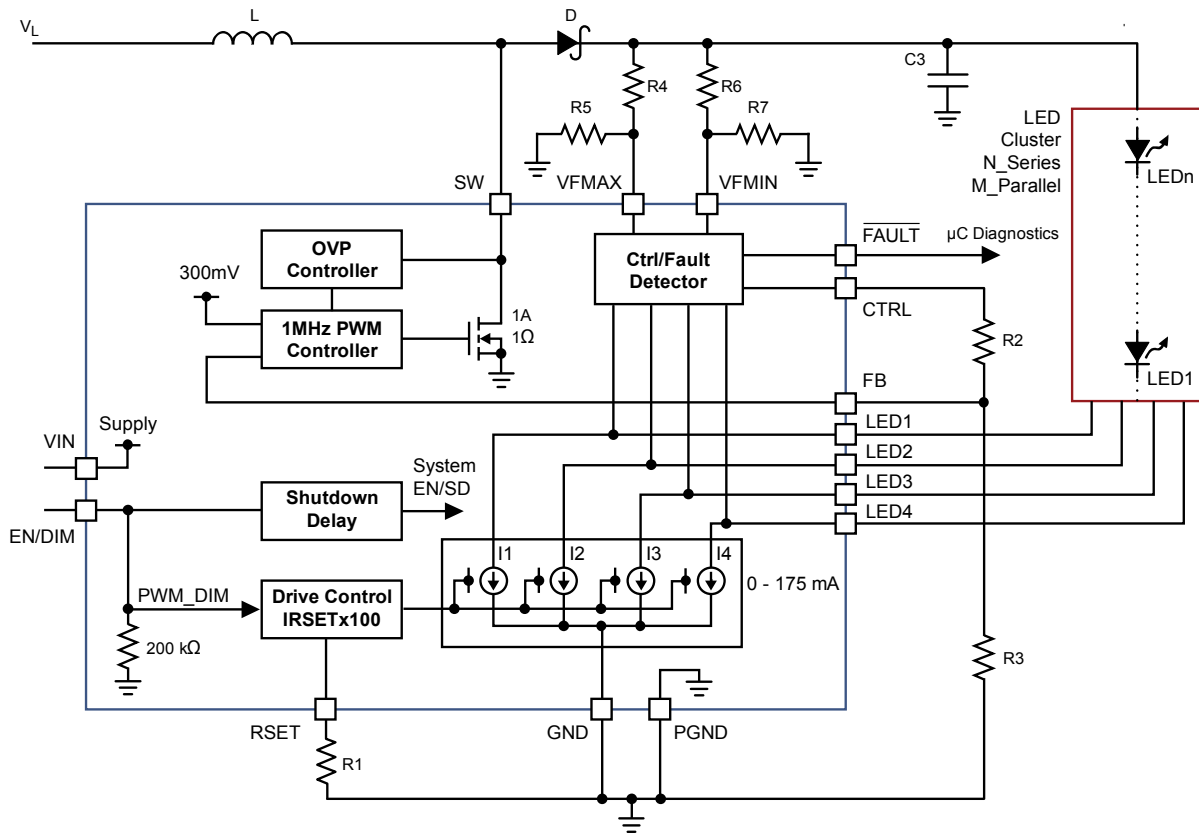

**Figure 4. CAT4106 Simplified Functional Block Diagram**

**DEVICE OPERATION**

In a typical application, the CAT4106 drives an LED array consisting of up to four separate strings. A single external resistor value is used to select the drive level in all output channels. Each channel provides a very well regulated and tightly matched bias current on all LED strings.

An integrated DC/DC boost converter is used to generate the high voltage output required to power the LED strings. Up to a maximum of 6 W of LED power can be delivered when powered from a 12 V supply.

To offer improved performance, the device also allows the user to set the operating voltage level on the output drive channels. A pair of external resistors is used to control the nominal channel voltage, during normal operation. The resulting output voltage (LED anodes) will be equal to the sum of the adjusted channel voltage plus the maximum forward voltage present on any string.

The CAT4106 provides four tightly matched current sinks to accurately regulate LED current in each channel. Up to 175 mA per channel can be programmed by selecting a suitable value for the

external R1 resistor (connected between RSET and GND pins).

**LED CURRENT SETTING**

The CAT4106 provides four tightly matched current sinks to accurately regulate LED current in each channel. The LED current is set by the external resistor R1 connected between the feedback pin (FB) and ground. The following formula gives the relationship between the resistor value and the LED current per channel.

$$R1 \approx 103 \times \frac{1.2 \text{ V}}{\text{LED current per channel}}$$

LED current per channel (mA)	R1 (Ω)
10	12.4 k
20	6.19 k
30	4.12 k
50	2.49 k
100	1.24 k
150	820

**Table 1. Resistor R1 and LED current**

## SETTING THE CHANNEL VOLTAGE

Each LED channel typically requires less than 0.5 V of headroom for full load operation. The lowest channel operating voltage can be controlled and programmed via the external resistor network connected between, CTRL, FB and GND as shown in Figure 4.

$$\text{Lowest LED pin voltage} = V_{FB} \times \frac{R2 + R3}{R3}$$

For most applications, a gain of 2x (R2 equals R3) is recommended. The CTRL output pin has optimal performance when loaded with around 15  $\mu$ A, which equates to an R3 resistor value of 20 k $\Omega$ .

## LED DETECTION

The CAT4106 detects failure conditions related to the LED load, such as if one of the LED strings has been disconnected (Open-LED) or if one LED string has a lower LED pin voltage than expected (Short-LED). Either condition is flagged by turning on the open-drain output on the FAULT pin. The Open-LED detection is active in normal operation. The Short-LED detection is only active during power-up, just after the EN/PWM input goes from low to high. If in normal operation (LEDs are in regulation) a short-LED condition occurs, it will not be detected.

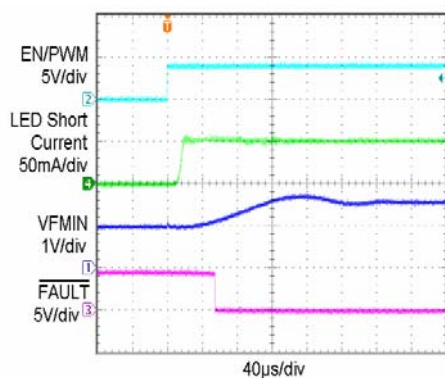

Figure 5. Cold Power-Up Short-LED Detection

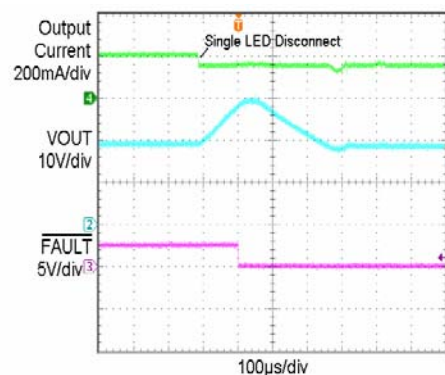

Figure 6. Normal Operation Open-LED Detection

The test condition in Figure 5 is with one LED pin shorted to the output (top LED anode). The test condition in Figure 6 is with one LED pin floating or disconnected. In both cases, the CAT4106 is set to drive 50 mA per channel.

## SETTING VFMIN LEVEL (SHORT-LED)

The VFMIN level represents the minimum level expected for the LED string voltage “window of operation”. This voltage setting is based on the number of series LEDs being used and the expected minimum forward voltage  $V_F$  during normal operation.

Example: Consider a string of 6 LEDs in series, with each LED having a  $V_F$  range of  $3.5 \text{ V} \pm 0.5 \text{ V}$ . Since the minimum  $V_F$  of each LED is 3.0 V the overall lowest expected string voltage would be 18 V. Any string voltage of less than 18 V is considered as a short-circuit fault in one or more of the series LEDs.

The external resistor R6 value needed to set a VFMIN level of 18 V is calculated as follows:

$$R6 = R7 \times \left( \frac{18 \text{ V}}{1.2 \text{ V}} - 1 \right)$$

For R7 = 20 k $\Omega$ , R6 = 280 k $\Omega$ .

## SETTING VFMAX LEVEL (OPEN-LED)

The VFMAX level represents the maximum level expected for the LED string voltage “window of operation”. This voltage setting is based on the number of series LEDs being used and the expected maximum  $V_F$  during normal operation.

Example: Consider a string of 6 LEDs in series, with each LED having a  $V_F$  range of  $3.5 \text{ V} \pm 0.5 \text{ V}$ . Since the maximum  $V_F$  of each LED is 4.0 V, the overall maximum expected string voltage would be 24 V. Any string voltage which appears greater than 24 V would be considered as containing an open-circuit in one or more of the series LEDs. The external resistor R4 value needed to set a VFMAX level of 24 V is calculated as follows:

$$R4 = R5 \times \left( \frac{24 \text{ V}}{1.2 \text{ V}} - 1 \right)$$

For R5 = 20 k $\Omega$ , R4 = 380 k $\Omega$ .

In normal operation, the LED string which has the largest  $V_F$  will be used to set the VCTRL/VFB voltage levels. If the largest string voltage tries to exceed VFMAX setting, it will no longer be allowed to control the voltage level of VCTRL/VFB (i.e it will be ignored) and subsequently the next largest LED string voltage will then be used in the control loop. All remaining functional LED channels will continue to operate as

normal. If a disconnected LED string is reconnected, the FAULT flag remains on and the channel disabled until the device has been re-enabled with the EN pin going from low to high.

If all LED channels are detected as being open-circuit, then the boost converter will limit the output voltage to the VFMAX setting. This eliminates the need for an external protection zener.

**ENABLE AND PWM DIMMING CONTROL**

EN/PWM input signal provides two independent functions. The first function is to enable and disable the entire device. The second function is to apply PWM dimming on the output channels while the chip remains fully enabled. Applying logic high on the EN/PWM input will power up the device. The device will continue to remain powered up, even in the presence of PWM signals being applied. To disable the device into complete system shutdown mode, a logic low must be applied to the EN/PWM input for typically 5 ms.

The duty cycle applied at the EN/PWM is directly applied to all the output channels. Each time the input is taken low, all output channels will immediately be switched off and the channels will resume normal operation when the PWM is taken back high. The response time of the channels when switching ON or OFF is typically 0.2 μs.

During PWM dimming, the recommended minimum pulse width interval (either High or Low) is 0.2 μs. The recommended maximum pulse width during PWM dimming is 2.5 ms, however this only applies to the Low pulse interval. Pulse durations extending past 2.5 ms may cause the device to enter full shutdown mode. The LED channel response time is much longer if the device has been in shutdown mode.

For most applications, a maximum dimming resolution can be achieved with PWM clock frequencies in the range of 100 Hz to 2 kHz. Pulse width intervals of 1 μs, allows up to 1000:1 dimming ratio at 1 kHz PWM frequency.

**ONE OR TWO LED STRING APPLICATIONS**

The CAT4106 can be used to drive one or two strings of LEDs by connecting together some LED pins. Also for applications requiring LED current greater than 175 mA, LED channels can be tied together, assuming the supply is suitable to drive the load. Figure 7 shows a typical application for driving a single string of LEDs. The LED current is equal to four times the channel current.

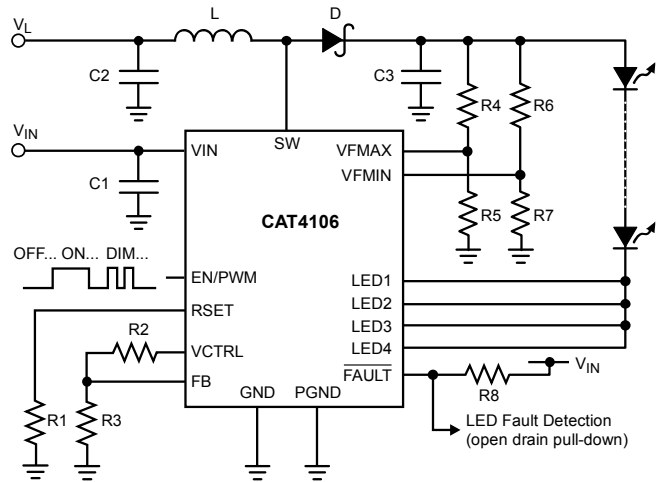

**Figure 7. Application Circuit for One LED String**

Figure 8 shows a typical application for driving two strings of LEDs. The LED current is equal to two times the channel current.

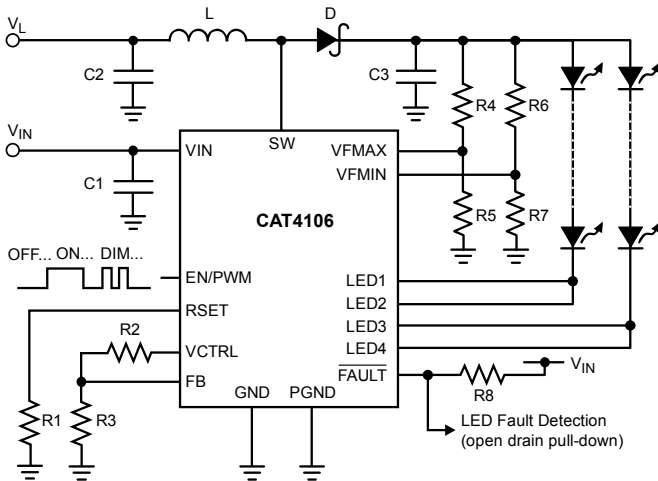

**Figure 8. Application Circuit for Two LED Strings**

## APPLICATION INFORMATION

### External Component Selection

#### Capacitors

The CAT4106 requires small ceramic capacitors of 1  $\mu\text{F}$  on the VIN pin (C1), 4.7  $\mu\text{F}$  on the inductor input (C2), and 10  $\mu\text{F}$  on the output (C3). Under normal condition, a 4.7  $\mu\text{F}$  input capacitor (C2) is sufficient. The voltage rating of each capacitor should be compatible with the maximum voltage applied. For the output, a 50 V rated capacitor (C3) is recommended in case the LED becomes disconnected (Open-LED condition). X5R and X7R capacitor types are ideal due to their stability across temperature range.

#### Inductor

A 47  $\mu\text{H}$  inductor is recommended for most applications. In cases where the efficiency is critical, inductances with lower series resistance are preferred. Inductors with current rating of 1 A or higher are recommended for most applications. Coilcraft CR73-470 inductor rated at 1.08 A is recommended for most applications.

#### Schottky Diode

The current rating of the Schottky diode (D) must exceed the peak current flowing through it. A 1A rated Schottky diode is recommended. The Schottky diode performance is rated in terms of its forward voltage at a given current. In order to achieve the best efficiency, this forward voltage should be as low as possible. The response time is also critical since the driver is operating at 1 MHz. NXP PMEG6010CEJ (60 V / 1 A rated) Schottky barrier rectifier is recommended for most applications.

### Recommended Layout

The board layout should provide good thermal dissipation through the PCB. Multiple via can be used to connect the tab of the CAT4106 to a large ground plane underneath the package.

Input capacitor C1 should be placed as close to the driver IC as possible. The RSET resistor (R1) and channel voltage setting resistor (R3) should have a Kelvin connection to the GND pin of the CAT4106.

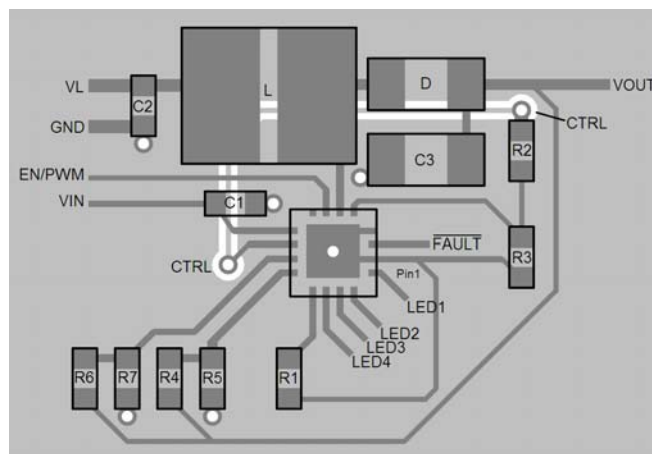
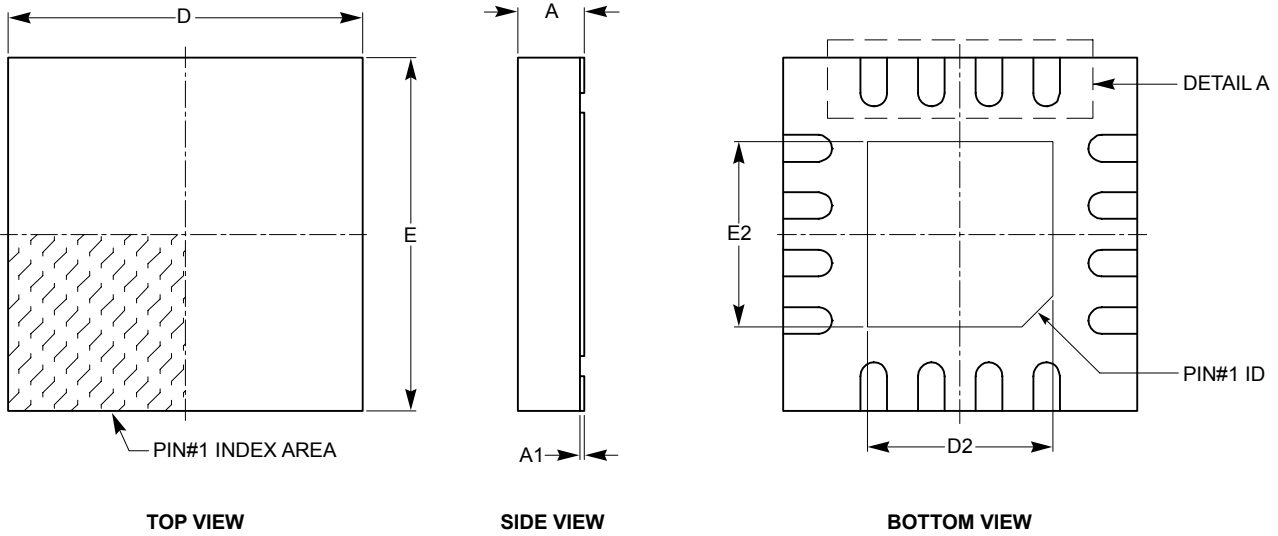
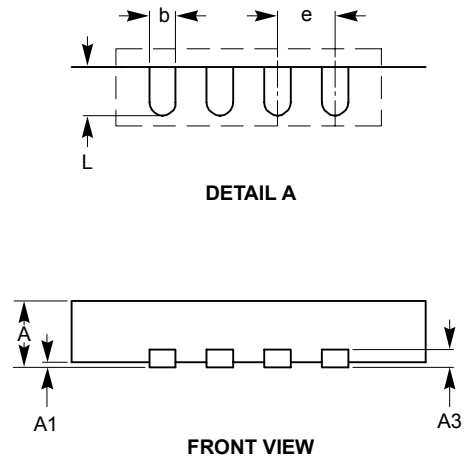

Figure 9. Recommended Layout for TQFN-16

**PACKAGE OUTLINE DRAWINGS**  
**TQFN 16-Pad 4 x 4 mm (HV4) <sup>(1)</sup> <sup>(2)</sup>**



SYMBOL	MIN	NOM	MAX
A	0.70	0.75	0.80
A1	0.00	0.02	0.05
A3	0.20 REF		
b	0.25	0.30	0.35
D	3.90	4.00	4.10
D2	2.00	-	2.25
E	3.90	4.00	4.10
E2	2.00	-	2.25
e	0.65 BSC		
L	0.45	-	0.65



**For current Tape and Reel information, download the PDF file from:**  
<http://www.catsemi.com/documents/tapeand reel.pdf>.

- Notes:**  
 (1) All dimensions are in millimeters. Angles in degrees.  
 (2) Complies with JEDEC standard MO-220

TSSOP 16-Lead Exposed Thermal Pad 4.4 mm (YP) <sup>(1) (2)</sup>

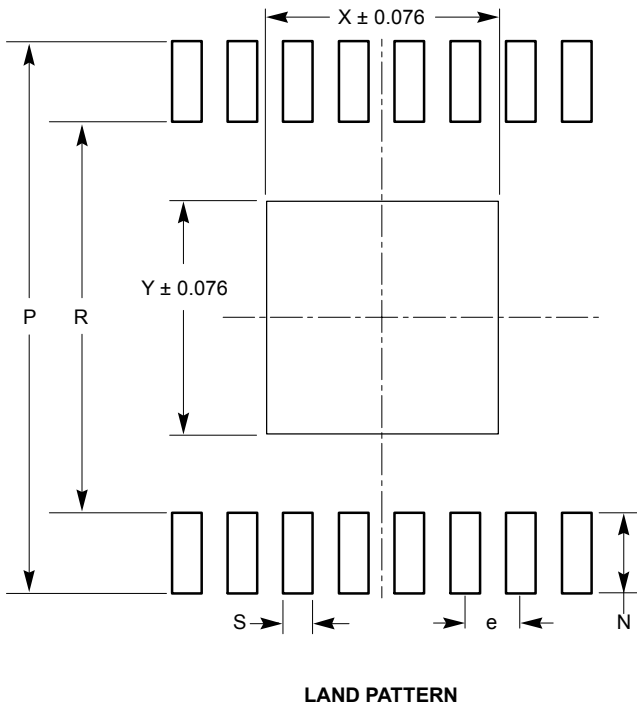
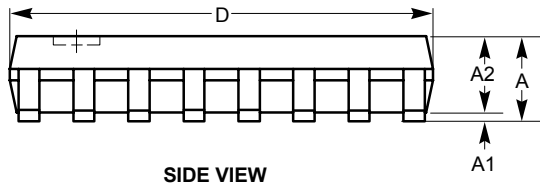
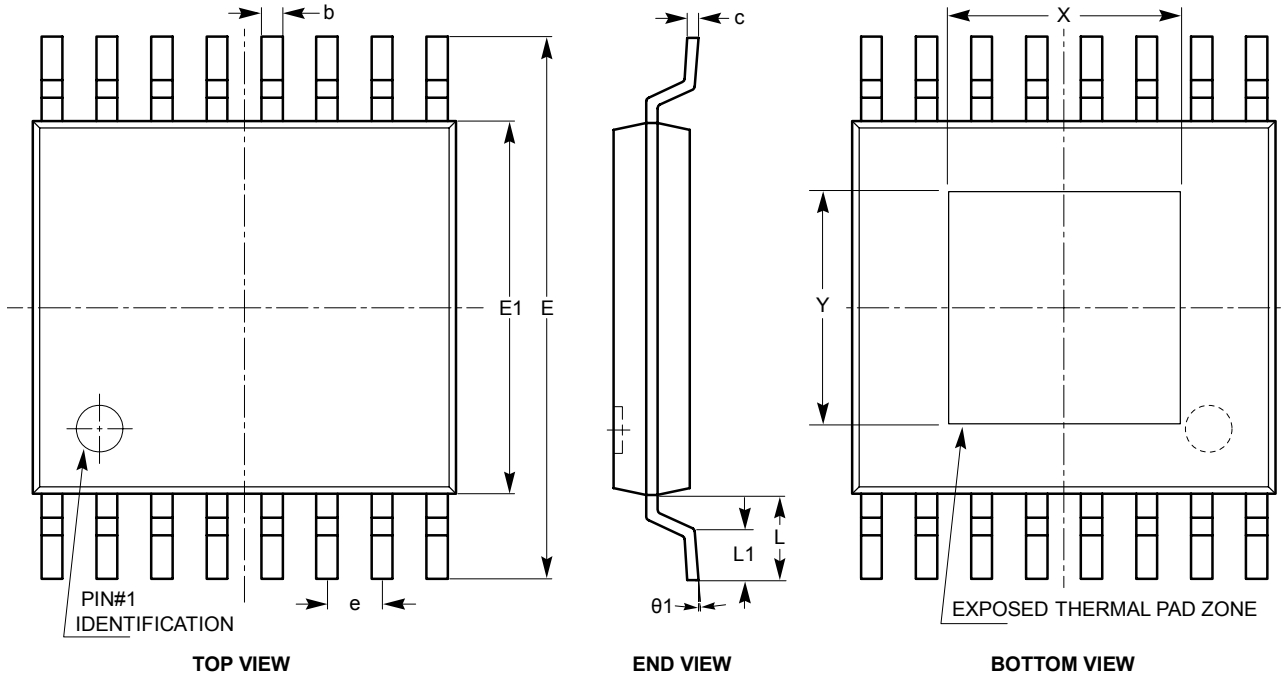

SYMBOL	MIN	NOM	MAX
A			1.10
A1	0.05		0.15
A2	0.85		0.95
b	0.19		0.30
c	0.13		0.20
D	4.90		5.10
E	6.30		6.50
E1	4.30		4.50
e	0.65 BSC		
L	1.00 REF		
L1	0.45		0.75
N	0.90		1.00
P	6.50		6.70
R	4.60		4.80
S	0.37		0.47
θ1	0°		8°
X		2.74 REF	
Y		2.74 REF	

Notes:

- (1) All dimensions are in millimeters. Angles in degrees.
- (2) Complies with JEDEC standard MO-153 variations ABT

For current Tape and Reel information, download the PDF file from:  
<http://www.catsemi.com/documents/tapeandreel.pdf>.

**EXAMPLE OF ORDERING INFORMATION**

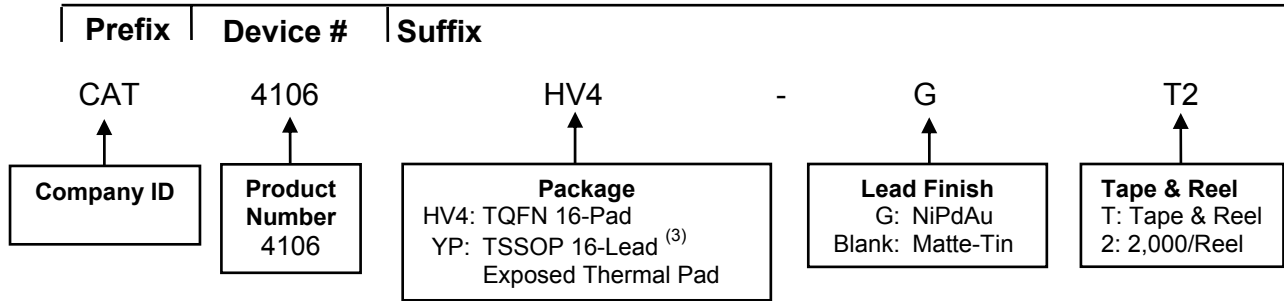

**For Product Top Mark Codes, click here:**  
<http://www.catsemi.com/techsupport/producttopmark.asp>

**Notes:**

- (1) All packages are RoHS-compliant (Lead-free, Halogen-free).
- (2) The standard plated finish is NiPdAu.
- (3) TSSOP only available in Matte-Tin plated finish.
- (4) The device used in the above example is a CAT4106HV4-GT2 (TQFN, NiPdAu, Tape & Reel, 2,000/Reel).
- (5) For additional temperature options, please contact your nearest ON Semiconductor Sales office.



**REVISION HISTORY**

Date	Revision	Description
17-Feb-09	A	Initial Issue

**ON Semiconductor** and  are registered trademarks of Semiconductor Components Industries, LLC (SCILLC). SCILLC reserves the right to make changes without further notice to any products herein. SCILLC makes no warranty, representation or guarantee regarding the suitability of its products for any particular purpose, nor does SCILLC assume any liability arising out of the application or use of any product or circuit, and specifically disclaims any and all liability, including without limitation special, consequential or incidental damages. "Typical" parameters which may be provided in SCILLC data sheets and/or specifications can and do vary in different applications and actual performance may vary over time. All operating parameters, including "Typicals" must be validated for each customer application by customer's technical experts. SCILLC does not convey any license under its patent rights nor the rights of others. SCILLC products are not designed, intended, or authorized for use as components in systems intended for surgical implant into the body, or other applications intended to support or sustain life, or for any other application in which the failure of the SCILLC product could create a situation where personal injury or death may occur. Should Buyer purchase or use SCILLC products for any such unintended or unauthorized application, Buyer shall indemnify and hold SCILLC and its officers, employees, subsidiaries, affiliates, and distributors harmless against all claims, costs, damages, and expenses, and reasonable attorney fees arising out of, directly or indirectly, any claim of personal injury or death associated with such unintended or unauthorized use, even if such claim alleges that SCILLC was negligent regarding the design or manufacture of the part. SCILLC is an Equal Opportunity/Affirmative Action Employer. This literature is subject to all applicable copyright laws and is not for resale in any manner.

**PUBLICATION ORDERING INFORMATION**

**LITERATURE FULFILLMENT:**

**Literature Distribution Center for ON Semiconductor**  
 P.O. Box 5163, Denver, Colorado 80217 USA  
**Phone:** 303-675-2175 or 800-344-3860 Toll Free USA/Canada  
**Fax:** 303-675-2176 or 800-344-3867 Toll Free USA/Canada  
**Email:** [orderlit@onsemi.com](mailto:orderlit@onsemi.com)

**N. American Technical Support:** 800-282-9855 Toll Free  
 USA/Canada  
**Europe, Middle East and Africa Technical Support:**  
 Phone: 421 33 790 2910  
**Japan Customer Focus Center:**  
 Phone: 81-3-5773-3850

**ON Semiconductor Website:** [www.onsemi.com](http://www.onsemi.com)  
**Order Literature:** <http://www.onsemi.com/orderlit>  
 For additional information, please contact your local Sales Representative