

## ■ FEATURES

- Fast Charge Control of NiMH/NiCd Batteries, even with a Fluctuating Charging Current.
- Fast Charge Termination by:  $\Delta T / \Delta t$ ,  $-\Delta V$ ,  $0\Delta V$ , Safety Timer, Maximum Temperature, Maximum Voltage.
- Linearly Adjustable  $\Delta T / \Delta t$  Detection Slope and Safety Timer.
- Protection against Battery Voltage and Battery Temperature Faults.
- Pulsed Trickle Charge Modes.
- Quick and Easy Testing for Production.
- 8-pin DIP or SO Packages.

## ■ APPLICATIONS

Battery Fast Chargers for:

- Mobile Phones.
- Notebook and Laptop Personal Computers.
- Portable Power Tools and Toys.
- Portable Communication Equipments.
- Portable Video & Stereo Equipments.

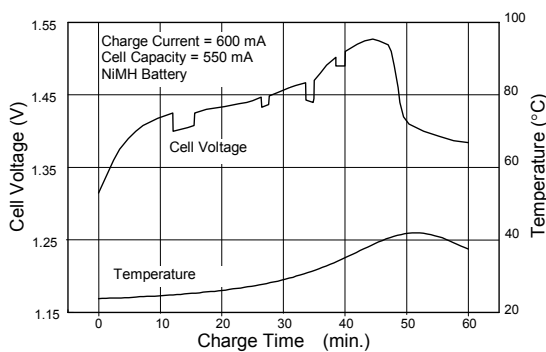

**Fig. 1 Battery Charging Characteristics Resulting from an AIC1784-Controlled Charger with a Fluctuating Charging Current**

## ■ DESCRIPTION

The AIC1784 fast charge controller IC is designed for intelligent charging of NiMH or NiCd batteries without the risk of overcharge.  $-\Delta V$  Detection ( $-0.25\%$ ),  $0\Delta V$  detection (peak voltage timer) and  $\Delta T / \Delta t$  detection are the primary methods employed by the AIC1784 to terminate fast charge. The fast charge can also be cut off by maximum battery voltage and maximum battery temperature detection along with the safety timer to prevent charging under fault conditions of the charging system or the battery itself.

Both  $\Delta T / \Delta t$  and  $-\Delta V$  detection methods have been proved powerful in terminating fast charging for NiMH and NiCd batteries. The AIC1784 utilizes the combination of these two methods to achieve reliable decision of ending fast charge and prevent misacting caused by using  $-\Delta V$  detection alone under certain conditions. Fig. 1 shows an example of charging curve of a battery charged by a fluctuating current from a NiMH battery charger, which uses the AIC1784 controller IC to achieve optimal charging. This technique, in cooperating with the  $0\Delta V$  detection (peak voltage timer), is particularly suitable for NiMH batteries, whose voltage drop is hardly significant yet temperature rises rapidly.

The safety timer period is adjustable. Test mode is provided for charger manufactures to dramatically reduce production test time.

## ■ TYPICAL APPLICATION CIRCUIT

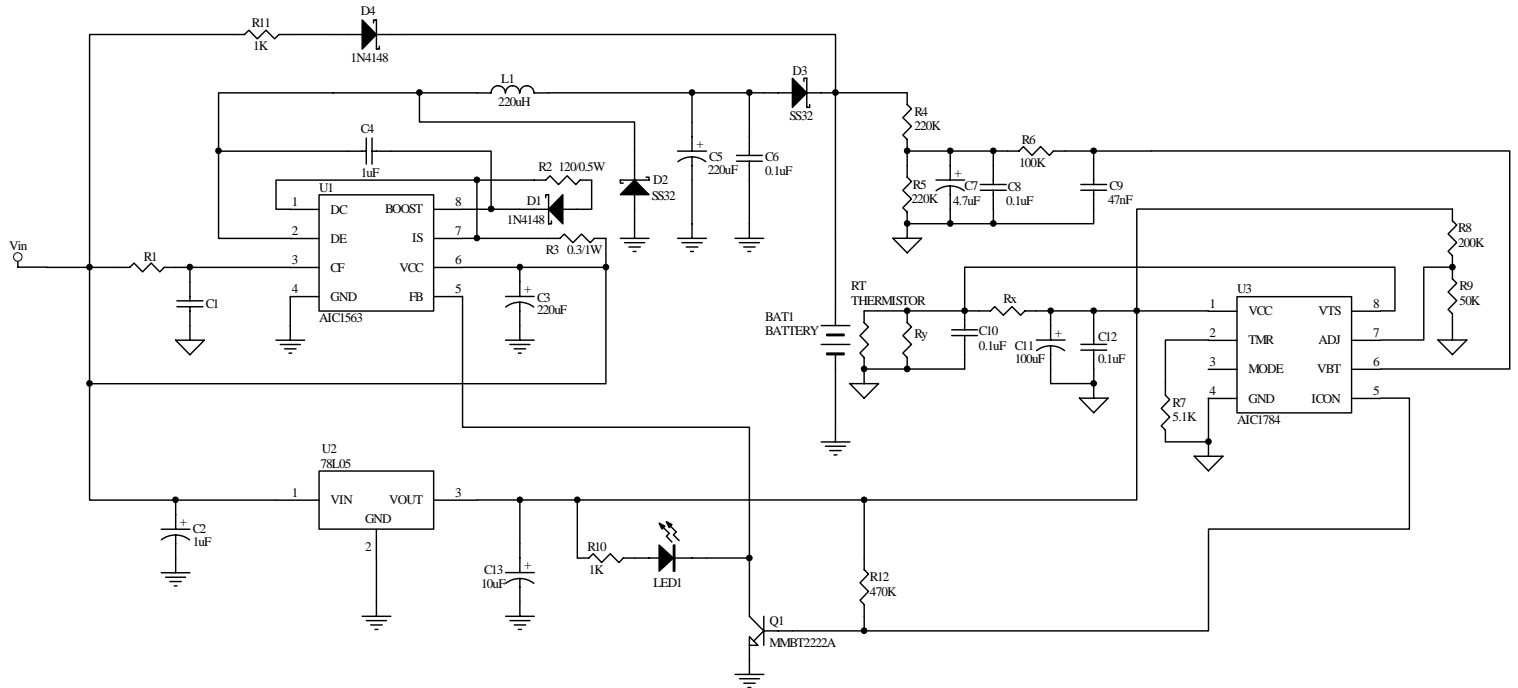

**Battery Charge Circuit for Fluctuating Charging Current Application**

## ■ ORDERING INFORMATION

AIC1784XXXX

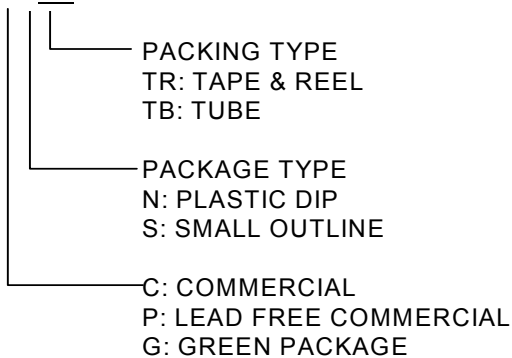

Example: AIC1784CSTR

→ in SO-8 Package & Tape & Reel Packing Type  
(CN is not available in TR packing type)

AIC1784PSTR

→ in SO-8 Lead Free Package & Tape & Reel  
Packing Type

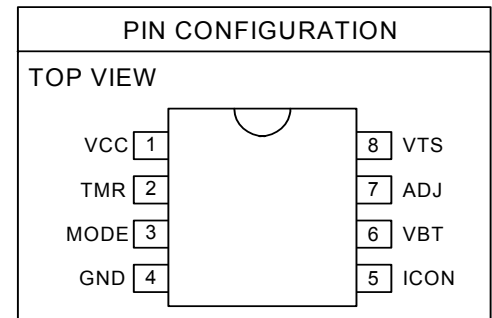

**■ ABSOLUTE MAXIMUM RATINGS**

Supply Voltage.....	5.5V
DC Voltage Applied on any pin.....	5.5V
Sink current of ICON pin.....	20mA
Operating Temperature Range.....	-40°C~ 85°C
Storage Temperature Range.....	-65°C~ 150°C
Junction Temperature Range.....	125°C
Lead Temperature (Soldering 10 sec) .....	260°C

*Absolute Maximum Ratings are those values beyond which the life of a device may be impaired.*

**■ TEST CIRCUIT**

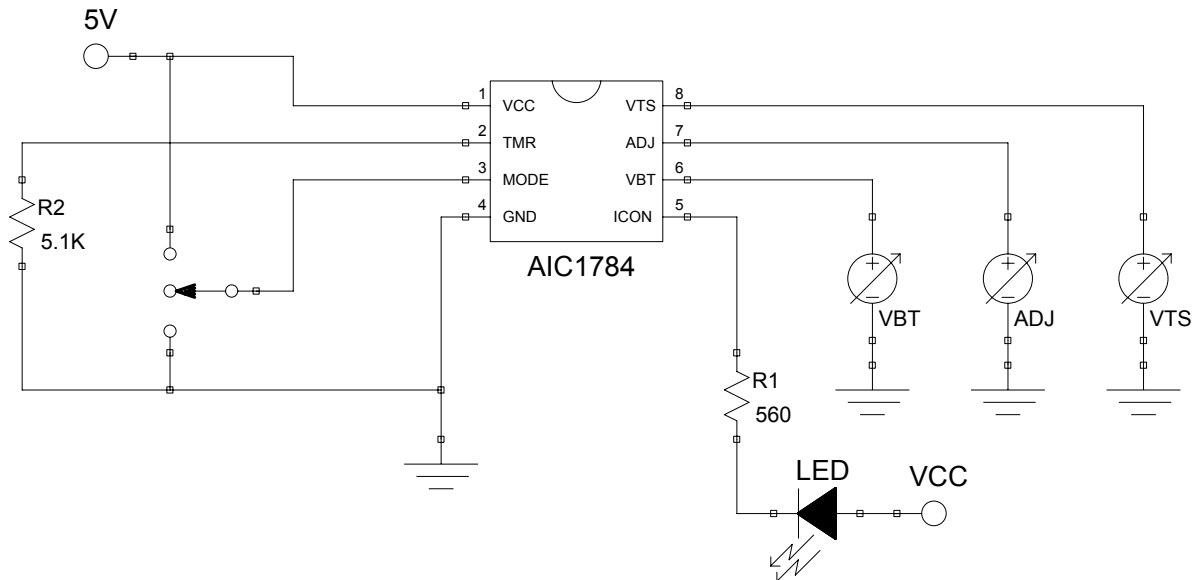

**ELECTRICAL CHARACTERISTICS** ( $T_A=25^{\circ}\text{C}$ ,  $V_{CC}=5\text{V}$ , unless otherwise specified.)

(Note1)

PARAMETER	TEST CONDITIONS	SYMBOL	MIN.	TYP.	MAX.	UNIT
Supply Voltage		$V_{CC}$	4.5	5.0	5.5	V
Supply Current		$I_{CC}$		1.1		mA
Voltage Protection Limit	Battery Low During Initial Timer	$V_{BT}$	0.11	0.16	0.21	V
	After Initial Timer		0.63	0.69	0.75	
	Battery High		2.6	2.7	2.80	
Temperature Sense Limit	Temperature High	$V_{TS}$	1.35	1.45	1.55	V
	Temperature Low		3.5	3.6	3.70	
Output Impedance(ICON pin)	ON			25	50	$\Omega$
	OFF		1			$M\Omega$
Input Impedance	MODE pin			300		$k\Omega$
	VBT, VTS, ADJ pins		1			$M\Omega$
Recommended External Resistor of TMR pin		$R_{TMR}$	0.9	5.1	27	$k\Omega$
Battery Charge Current (Note2, Note3, Note4)	Temperature detective function is enabled. Battery's type is GP180AAHC		0.25	0.8	1	C
$-\Delta V$ Detection Level w.r.t. Peak Value				-0.25		%

\* w.r.t.: with respect to

**Note 1:** Specifications are production tested at  $T_A=25^{\circ}\text{C}$ . Specifications over the  $-40^{\circ}\text{C}$  to  $85^{\circ}\text{C}$  operating temperature range are assured by design, characterization and correlation with Statistical Quality Controls (SQC).

**Note 2:** Guaranteed by battery's specification.

**Note 3:** Disable the temperature detective function is not recommended. Disable the temperature detection function may cause the detection error in some condition. (For example, battery over discharge)

**Note 4:** Generally the electrical current for charge or discharge is expressed in terms of a multiplier of C. For example, if the capacity is 1800mAh, we have the following:  $0.1C=0.1*1800=180\text{mA}$ .

**TYPICAL PERFORMANCE CHARACTERISTICS** ( $T_A=25^\circ\text{C}$ ,  $R_2=5.1\text{K}\Omega$ ,  $V_{CC}=5\text{V}$ , refer to Test Circuit)

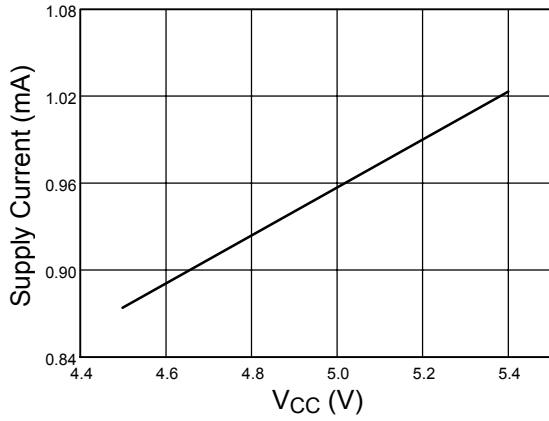

Fig.2 Supply Current vs. Supply Voltage

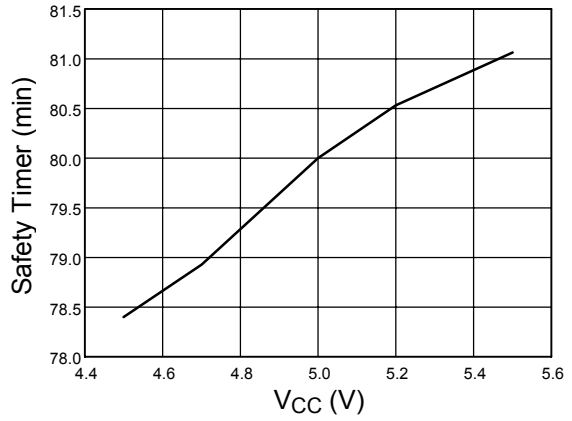

Fig.3 Safety Timer vs. Supply Voltage

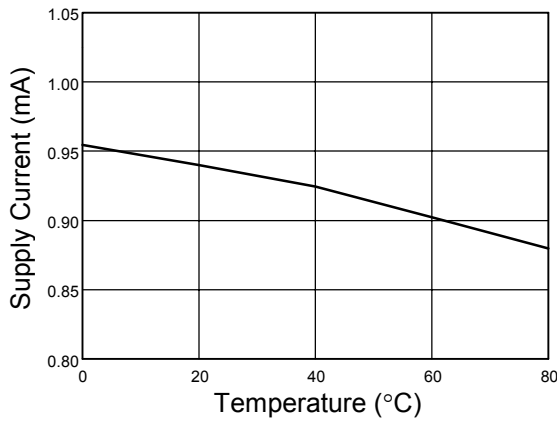

Fig.4 Supply Current vs. Temperature

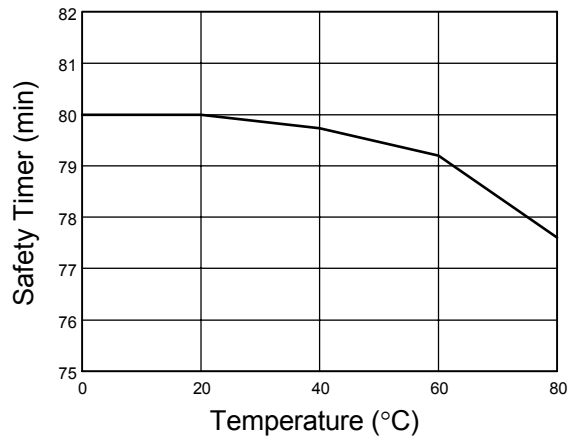

Fig.5 Safety Timer vs. Temperature

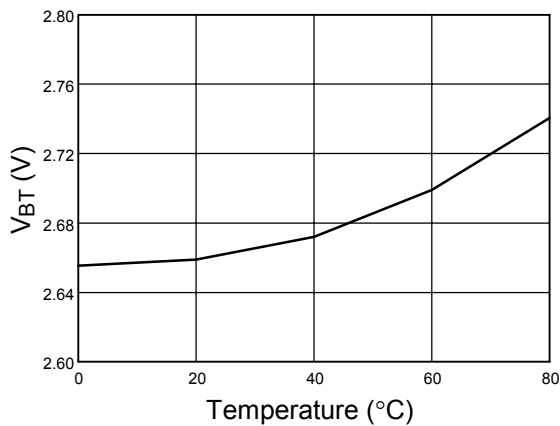

Fig.6 V<sub>BT</sub> (High) Limit vs. Temperature

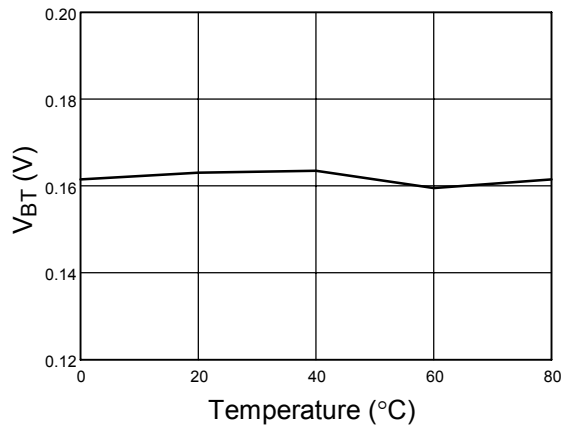

Fig.7 V<sub>BT</sub> (Low) Limit vs. Temperature (During Initial Timer)

■ TYPICAL PERFORMANCE CHARACTERISTICS (Continued)

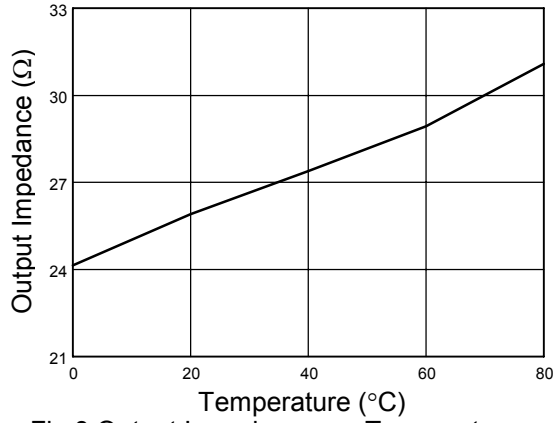

Fig.8 Output Impedance vs. Temperature (ICON Pin)

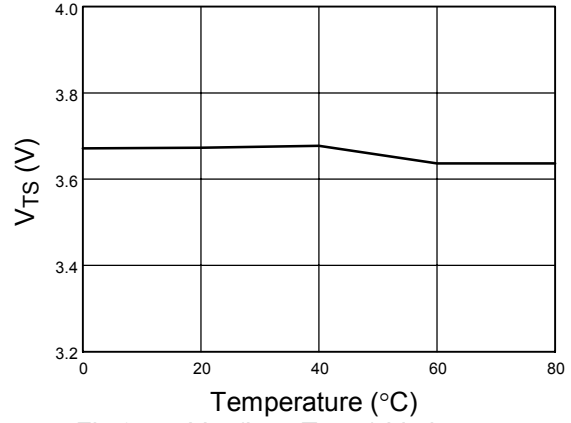

Fig.9 V<sub>TS</sub> (Low Temp) Limit vs. Temperature

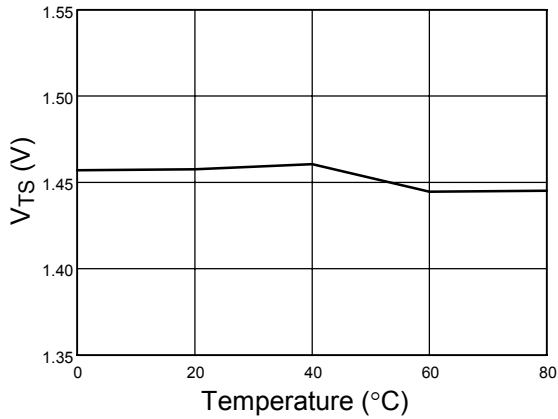

Fig.10 V<sub>TS</sub> (High Temp) Limit vs. Temperature

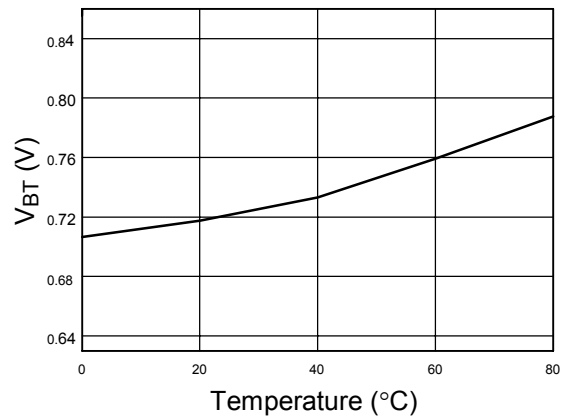
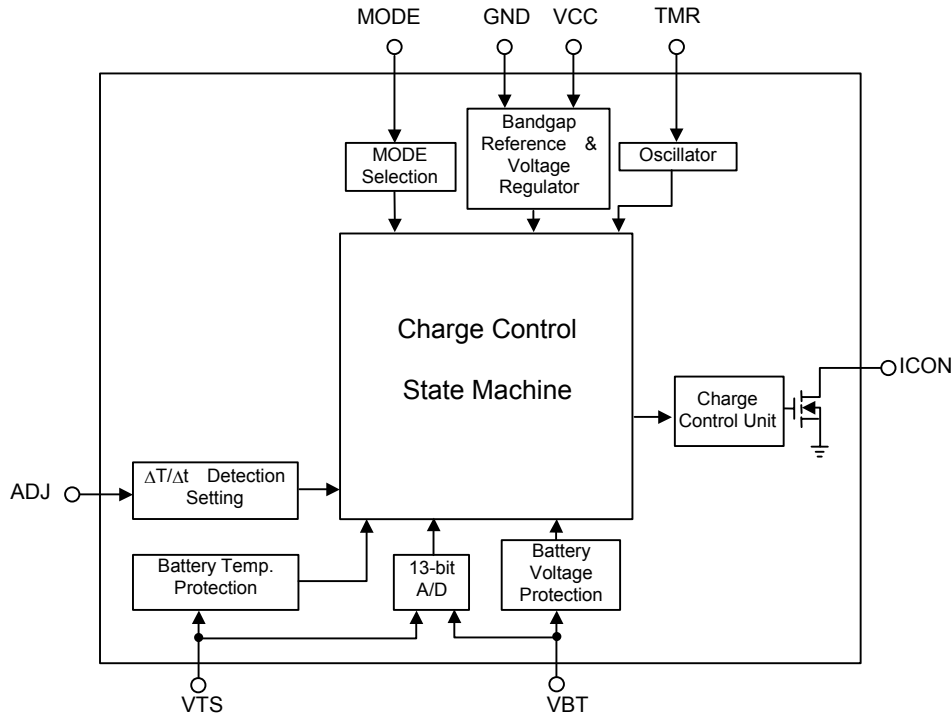

Fig.11 V<sub>BT</sub> (Low) Limit vs. Temperature (After Initial Timer)

## ■ BLOCK DIAGRAM



## ■ PIN DESCRIPTIONS

- PIN 1: VCC- Power supply input at  $5V \pm 10\%$ .
- PIN2: TMR- Determine the period of safety timer with an external resistor connected to GND.
- PIN 3: MODE- Determine the mode of operation for the AIC1784.
- PIN 4: GND- Power ground.
- PIN 5: ICON- Open-drained output, used to control the charging current to the battery.
- PIN 6: VBT- Divided battery voltage input to sense the battery voltage.
- PIN 7: ADJ- For adjusting the slope of  $\Delta T/\Delta t$ . Acceptable voltage range for

this pin is approximately 0.28V to 3.8V. If voltage higher than  $V_{CC}-0.3V$ , the function of  $\Delta T/\Delta t$  detection is disabled.

- PIN 8: VTS- The battery cell temperature is represented as a voltage input to the AIC1784 at this pin. The acceptable voltage range of VTS pin is  $0.29V_{CC}$  to  $0.72V_{CC}$ . The battery temperature is regarded as too high if the voltage of VTS pin is lower than  $0.29V_{CC}$ , and is otherwise regarded as too low if the voltage of VTS pin is higher than  $0.72V_{CC}$ .

## ■ APPLICATION INFORMATION

### ● THE AIC1784 OPERATION

#### Power-on and Battery Pre-qualifying

When power is first applied to the AIC1784, all internal digital circuit blocks of the AIC1784 are reset by the internal power-on-reset circuitry. The internal control unit then examines the battery condition through the VBT and VTS pins.

The acceptable range of VBT pin is 0.16V to 2.7V and the acceptable temperature sense voltage window for VTS pin is  $0.29 V_{CC}$  to  $0.72 V_{CC}$ . If the voltage of VBT pin fails to fall within the predetermined acceptable limits, the AIC1784 enters a charge-suspending mode, in which all the internal circuitry remains in reset state. If the voltage of VTS pin is outside the  $0.29 V_{CC}$  to  $0.72 V_{CC}$  window, AIC1784 enters a charge-suspending mode.

#### Fast Charge

After the battery passes fault checks, fast charging begins while initial timer and safety timer of the AIC1784 start counting. Functions of  $-\Delta V$  detection, peak voltage timer,  $\Delta T/\Delta t$  detection, and maximum battery voltage are, however, disabled temporarily until the initial timer period in the initial stage of a charge cycle elapses. The initial timer period is equal to 1/80 of safety timer.

Since the low limit of acceptable VBT voltage is only about 0.16V during the initial timer period, even deeply discharged batteries can easily qualify to be fast charged subsequently.

In the course of fast charge, the AIC1784 constantly monitors the voltages at VBT and VTS pins. The fast charge process is switched to trickle charge when any one of the following situations is encountered, which are explained below:

- Negative delta voltage ( $-\Delta V$ )
- Peak voltage timer ( $0\Delta V$ )

- Delta temperature/ delta time ( $\Delta T/\Delta t$ )
- Maximum charge time
- Maximum battery voltage
- Maximum battery temperature

#### $-\Delta V$ Cutoff

The AIC1784 makes a voltage sampling at VBT pin every 4 seconds when safety timer period is set equal to 80 minutes. If a negative delta voltage of 0.25% compared to its peak value is detected at VBT pin, the fast charge cycle is terminated.

#### $0\Delta V$ Cutoff

If the battery voltage stays at its peak value or decreases very slowly for the duration, which is 6% of safety time, the fast charge action is terminated.

#### $\Delta T/\Delta t$ Cutoff

The  $\Delta T/\Delta t$  detection of the AIC1784 is performed by sensing the decrease of VTS pin voltage in a specific timer interval dictated by the safety timer. The fast charging terminates when the decrease of VTS pin voltage in 56 seconds exceeds the predetermined value set by ADJ pin input. This time interval of 56 seconds is based on the assumption that voltage of VTS pin is sampled once for every 8 seconds, which is also determined by safety timer.

Functioning of  $-\Delta V$  detection and peak voltage timer ( $0\Delta V$ ) can be disabled if the MODE pin is biased to GND. Functioning of  $\Delta T/\Delta t$  detection can be disabled if the voltage of ADJ pin is higher than  $V_{CC} - 0.3V$ .

#### Maximum Safety Timer Cutoff

The maximum fast charge period is determined by the safety timer, which is set by a resistor connected from TMR pin to GND. Safety timer,  $-\Delta V$  sampling rate, and  $\Delta T/\Delta t$  sampling rate will be longer if the resistor value is larger. When the value of the



resistor is  $5.1K\Omega$ , the safety timer period equals 80 minutes. After the safety timer period is finished, the fast charge action is terminated.

**Maximum Voltage and Temperature Cutoff**

The AIC1784 guards against the maximum limits for battery voltage and temperature during fast charging. If either of these limits is exceeded, fast charge action is terminated.

**Trickle Charge**

The trickle charge after the fast charge can prevent the loss of charge due to battery self-discharging. The duty cycle is set to 1/128 by internal circuitry.

The functions and charging states control mentioned above are illustrated in the function flow chart of AIC1784 (Fig. 12)

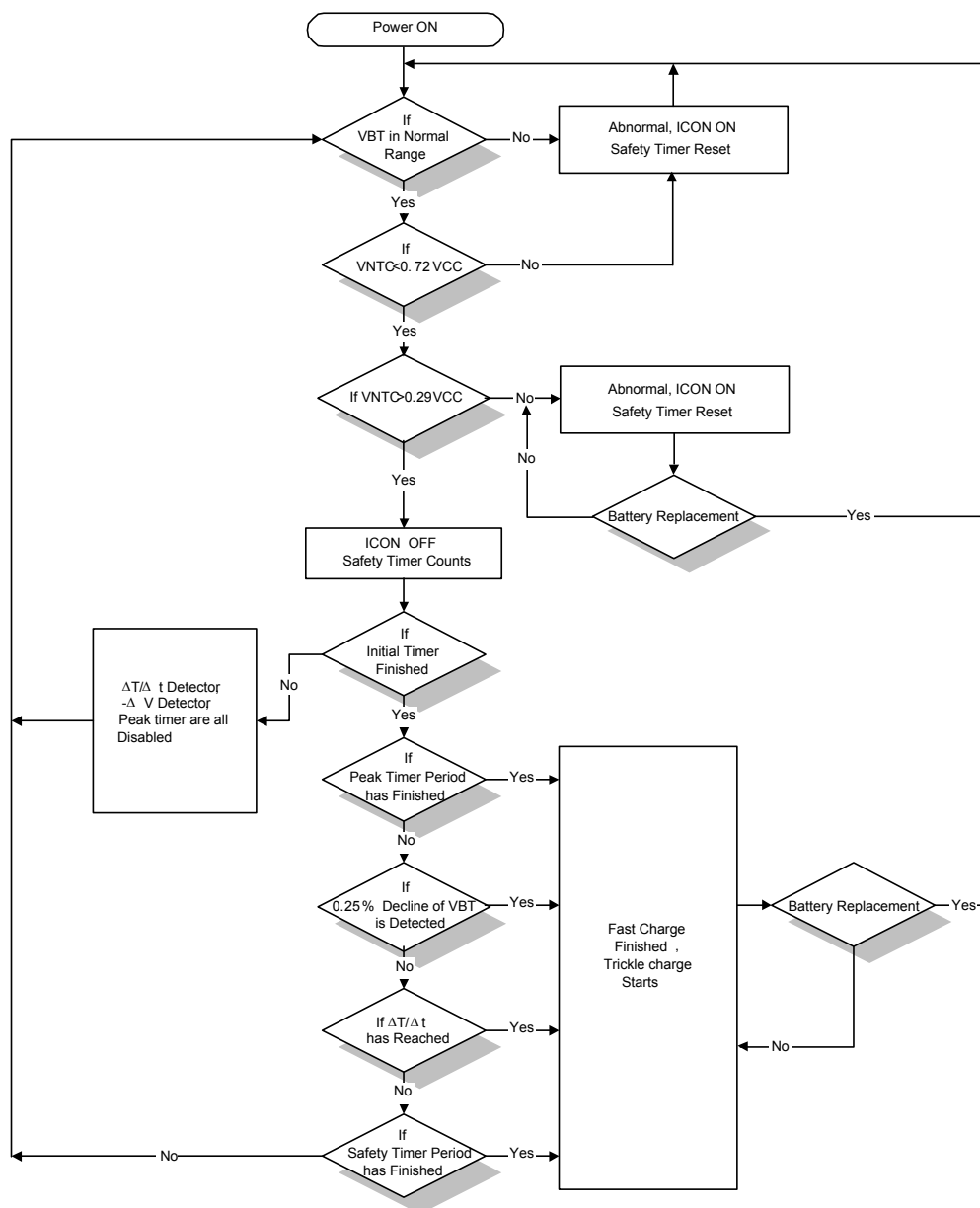
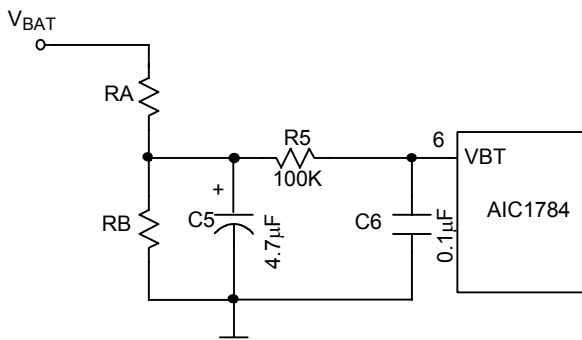

Fig. 12 Function Flow Chart of AIC1784

**● DESIGN GUIDE**
**Battery Voltage Measurement**

The AIC1784 measures the battery voltage through VBT pin, which is connected to battery positive terminal through a resistor-divider network, as shown in Fig. 13

**Fig. 13 Battery Voltage Divider**

The suggested divider resistance of RA and RB for the corresponding number of battery cells are as below:

**TABLE 1**

BATTERY CELLS	RA/RB	RA (KΩ)	RB (KΩ)
2~4	2	240	120
3~6	3.3	300	91
4~8	4.9	300	62
5~10	6.4	300	47
6~12	7.8	310	39
8~16	10.8	390	36

**Battery Temperature Measurement**

The AIC1784 employs a negative temperature coefficient (NTC) thermistor to measure the battery's temperature. The thermistor is inherently nonlinear with respect to temperature. To reduce the effect of nonlinearity, a resistor-divider network

in parallel with the thermistor is recommended. A typical application circuit is shown in Fig. 14.

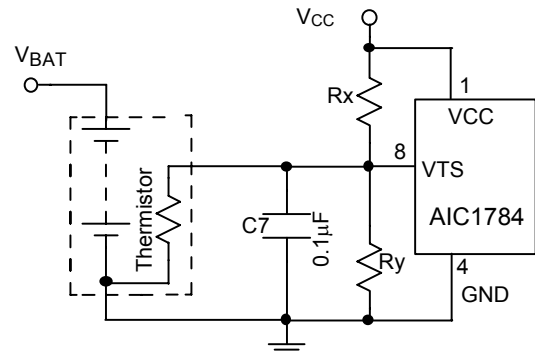
**Fig. 14 Battery Temperature Sense Circuit with a Negative Temperature Coefficient (NTC) Thermistor**

The calculation for Rx and Ry in the circuit is as following.

$$0.29 V_{CC} = \frac{R_y // R_{TH}}{R_x + (R_y // R_{TH})} \times V_{CC}$$

$R_{TH}$  = The resistance of thermistor at upper limit of temperature protection.

$$0.72 V_{CC} = \frac{R_y // R_{TL}}{R_x + (R_y // R_{TL})} \times V_{CC}$$

$R_{TL}$  = The resistance of thermistor at lower limit of temperature protection.

Substitution and rearranging the equations yield

$$R_x = 2.061 \times \frac{R_{TL} \times R_{TH}}{R_{TL} - R_{TH}}$$

$$R_y = \frac{5.3 \times R_{TL} \times R_{TH}}{R_{TL} - 6.3 R_{TH}}$$

If temperature characteristic of the thermistor is like that of SEMITEC 103AT-2, the resistance of Rx and Ry is tabulated for different TL and TH as below.

(Note: TL is lower temperature limit and TH is upper temperature limit.)

**TABLE 2 Values of Rx and Ry at TL = 0°C**

TH (°C)	Rx(KΩ)	Ry (KΩ)
50	10.1	551.1
51	9.7	300.7
52	9.4	204.8
53	9.0	153.9
54	8.7	122.8
55	8.4	101.8
56	8.1	86.5
57	7.8	75.0
58	7.5	66.0
59	7.2	58.7
60	7.0	52.8
61	6.8	47.8
62	6.5	43.6
63	6.3	39.9
64	6.1	36.8
65	5.9	34.0
66	5.7	31.6
67	5.5	29.5
68	5.3	27.5
69	5.2	25.8
70	5.0	24.3

**TABLE 3 Values of Rx and Ry at TL = -10°C**

TH (°C)	Rx (KΩ)	Ry (KΩ)
45	11.4	95.6
46	11.0	85.0
47	10.6	76.2
48	10.2	68.9
49	9.8	62.8
50	9.5	57.5
51	9.1	52.9
52	8.8	48.8
53	8.5	45.3
54	8.2	42.1
55	7.9	39.4
56	7.6	36.8
57	7.4	34.6
58	7.1	32.5
59	6.9	30.7

60	6.7	29.0
61	6.4	27.4
62	6.2	26.0
63	6.0	24.6
64	5.8	23.4
65	5.6	22.2

### Setting the ADJ Pin Voltage

The slope of  $\Delta T/\Delta t$  detection is determined by ADJ pin voltage of the AIC1784.

The calculation of ADJ pin voltage is shown in the following procedure followed by an example.

### Procedure

- (a) First, determine the temperature protection limits TH and TL. Then, substitute TH & TL into the following equation:

$$\frac{\Delta V_{TS}}{\Delta T_{BASE}} = \frac{0.72 V_{CC} - 0.29 V_{CC}}{TH - TL} = \frac{0.43 V_{CC}}{TH - TL}$$

- (b) Determine the safety timer to obtain the value of  $\Delta t_{BASE}$ .

$$\Delta t_{BASE}(\text{sec.}) = \frac{56(\text{sec.})}{80(\text{min.})} \times \text{Safety Timer}(\text{min.})$$

- (c) Determine the expected slope of  $\Delta T / \Delta t$  at which temperature rises  $y^\circ\text{C}$  in  $x$  seconds and fast charge is subsequently cut off.

$$\frac{\Delta T}{\Delta t} = \frac{y}{x}$$

- (d) Calculate the value of  $V_{ADJ}$

$$V_{ADJ} = 30 \times \frac{\Delta V_{TS}}{\Delta T_{BASE}} \times \frac{\Delta T}{\Delta t} \times \Delta t_{BASE}$$

### Example

- (a) Let TH=50°C, TL=0°C,  $V_{CC}$  =5V. We have

$$\frac{\Delta V_{TS}}{\Delta T_{BASE}} = \frac{0.43 \times 5}{50 - 0} = 0.043\text{V}/^\circ\text{C}$$

which means that  $V_{TS}$  decreases 43mV as temperature rises 1°C.

- (b) If safety timer is equal to 80 minutes,  $\Delta t_{BASE}$  is then 56 seconds.

- (c) If fast charge should be terminated when temperature rises 1°C in 60 seconds, then

$$\Delta T / \Delta t = \frac{1}{60} = 0.0166$$

$$(d) V_{ADJ} = 30 \times 0.043 \times 0.0166 \times 56 = 1.2(V)$$

If the temperature range is from 0°C to 50°C, the voltage of  $V_{ADJ}$  under different setting conditions should be set as tabulated below.

**TABLE 4 ADJ pin Voltage (TL=0°C, TH=50°C)**

$\Delta T / \Delta t$ S.T.	0.75 (°C/min.)	1.0 (°C/min.)	1.25 (°C/min.)
40 min. (2C)	0.45	0.60	0.75
80 min. (1C)	0.90	1.20	1.50
120 min. (0.67C)	1.35	1.80	2.25
160 min. (0.5C)	1.80	2.40	3.01
200 min. (0.4C)	2.25	3.01	3.76
240 min. (0.33C)	2.70	3.61	X

A similar table for temperature range from 0°C to 60°C is as below.

**TABLE 5 ADJ Pin Voltage (TL=0°C, TH=60°C)**

$\Delta T / \Delta t$ S.T.	0.75 (°C/min.)	1.0 (°C/min.)	1.25 (°C/min.)
40 min. (2C)	0.37	0.50	0.62
80 min. (1C)	0.75	1.00	1.25
120 min. (0.67C)	1.12	1.50	1.88
160 min. (0.5C)	1.50	2.00	2.50
200 min. (0.4C)	1.88	2.50	3.13
240 min. (0.33C)	2.25	3.01	3.76

### VBT Range and Temperature Protection

Acceptable VBT Range:

Before initial timer: 0.16V~2.7V

After initial timer: 0.69V~2.7V

Temperature Protection Mode:

Entering charge-suspending mode when temperature is either too low or too high, same as abnormal battery voltage. Latch for charge-suspending function is provided for high temperature protection, but not for low temperature protection.

### Setting the Period of Safety Timer

The AIC1784 provides a method for linearly adjusting the period of safety timer with an

external resistor connected from TMR pin to GND. The relation between safety timer length and the external resistor ( $R_{TMR}$ ) is shown in Fig. 15. The table following shows the resistor values for some of the commonly chosen safety timer periods. Also shown in the table are their corresponding oscillator frequencies.

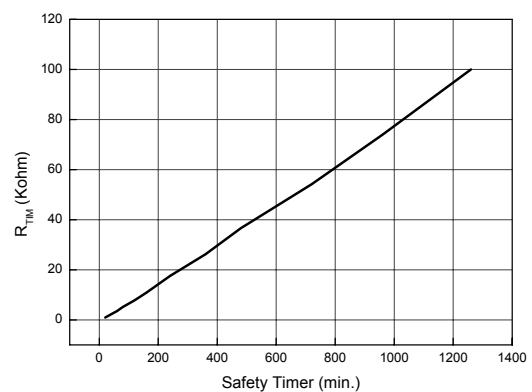
**Fig. 15 Safety Timer vs.  $R_{TMR}$** 
**TABLE 6**

$R_{TMR}$ (K $\Omega$ )	OSC. Freq.(KHz)	Safety timer (min.)
0.9	2100	20
2.2	1049.6	40
3.5	704	60
5.1	518.4	80
7.8	353.6	120
10.9	264	160
17.5	174.4	240
26.2	116.8	360

### Selecting Mode of Operation

The AIC1784 provides three modes of operation: normal, test, and AC mode determined by the setting of MODE pin according to TABLE 7. The AIC1784 will operate normally when the MODE pin is left floating (a 0.1 $\mu$ F capacitor is recommended to be tied to MODE pin if the charge circuit works in a noisy environment). When the MODE pin is biased to GND, the function of  $-\Delta V$  detection is disabled. When the MODE pin is biased to VCC,

the AIC1784 enters the test mode. The test mode can be used to significantly reduce production test time. For relevant information please contact AIC directly.

**TABLE 7 The Operating Mode of AIC1784**

MODE pin	Mode	Function
VCC	Test	Safety timer period scaled down to 1/512....etc.
Floating	Normal	Normal operation
GND	AC	- ΔV detection disabled

**Charging Current Control**

As shown in the typical application circuit, the AIC1784 offers an open-drained output pin, ICON pin, to control the charging current flow in fast charge state and switch on to inhibit the charging current flow in fault conditions. When fast charge is completed, the AIC1784 enters the trickle charge mode. In trickle charge mode, the ICON pin output switches with 1/128 duty cycle. The following table summarizes how ICON pin corresponds to various charging states.

	Power ON	Fast Charging	Charge Completed	Fault Conditions
ICON	ON	OFF	1/128 duty cycle	ON

**Test Mode**

Fig. 16 shows the timing diagram for externally controlled ADJ, VBT and VTS pin voltages of a recommended AIC1784 test scheme, utilizing TEST mode function. Output waveform of ICON of a properly functioning AIC1784 is also shown in the figure.

### TIMING DIAGRAM

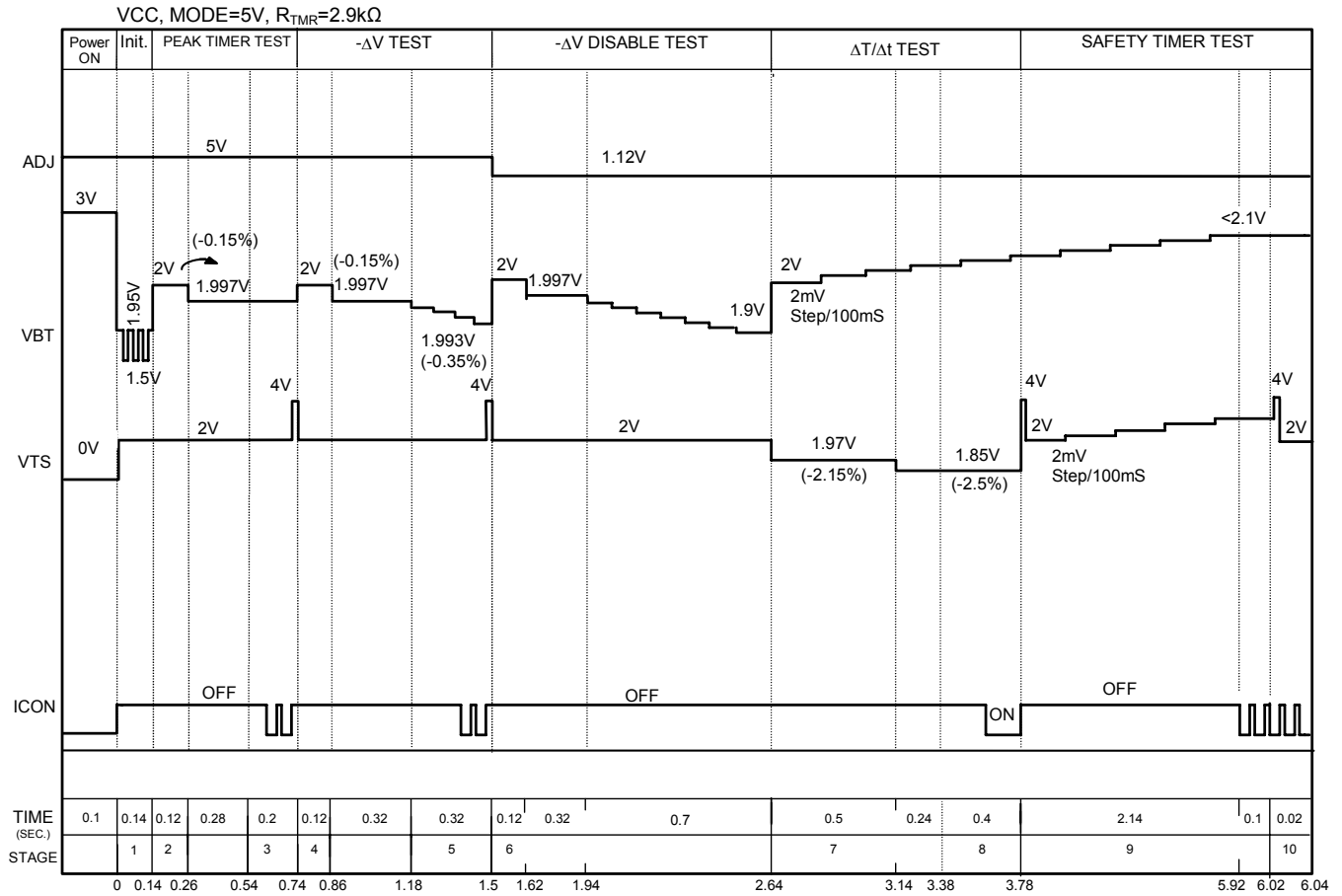
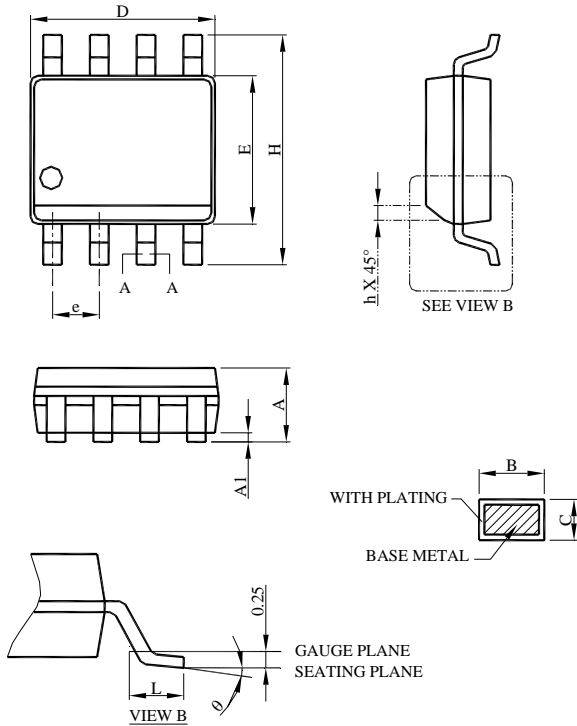

Fig. 16 Timing Diagram of AIC1784 in Test Mode

■ PHYSICAL DIMENSIONS (unit: mm)

● SOP-8



SYMBOL	SOP-8	
	MILLIMETERS	
	MIN.	MAX.
A	1.35	1.75
A1	0.10	0.25
B	0.33	0.51
C	0.19	0.25
D	4.80	5.00
E	3.80	4.00
e	1.27 BSC	
H	5.80	6.20
h	0.25	0.50
L	0.40	1.27
θ	0°	8°

Note:

1. Refer to JEDEC MS-012AA.
2. Dimension "D" does not include mold flash, protrusions or gate burrs. Mold flash, protrusion or gate burrs shall not exceed 6 mil per side.
3. Dimension "E" does not include inter-lead flash or protrusions.
4. Controlling dimension is millimeter, converted inch dimensions are not necessarily exact.

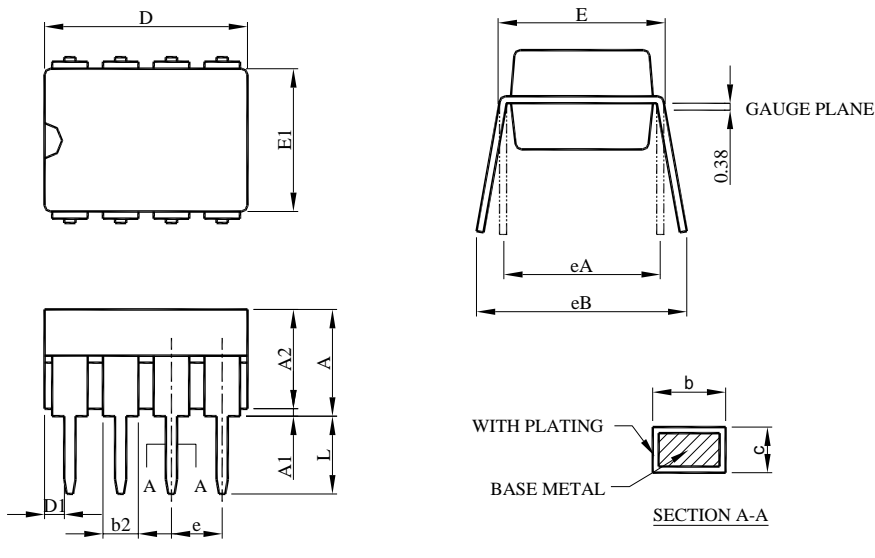
**● DIP-8**

SYMBOL	DIP-8	
	MILLIMETERS	
	MIN.	MAX.
A		5.33
A1	0.38	
A2	2.92	4.95
b	0.36	0.56
b2	1.14	1.78
c	0.20	0.35
D	9.01	10.16
D1	0.13	
E	7.62	8.26
E1	6.10	7.11
e	2.54 BSC	
eA	7.62 BSC	
eB		10.92
L	2.92	3.81

**Note:**

- 1.Refer to JEDEC MS-001BA.
- 2.Dimension "D" does not include mold flash, protrusions or gate burrs.  
Mold flash, protrusion or gate burrs shall not exceed 10 mil per side.
- 3.Dimension "D1" and "E1" do not include inter-lead flash or protrusions.
- 4.Controlling dimension is millimeter, converted inch dimensions are not necessarily exact.

**Note:**

Information provided by AIC is believed to be accurate and reliable. However, we cannot assume responsibility for use of any circuitry other than circuitry entirely embodied in an AIC product; nor for any infringement of patents or other rights of third parties that may result from its use. We reserve the right to change the circuitry and specifications without notice.

Life Support Policy: AIC does not authorize any AIC product for use in life support devices and/or systems. Life support devices or systems are devices or systems which, (i) are intended for surgical implant into the body or (ii) support or sustain life, and whose failure to perform, when properly used in accordance with instructions for use provided in the labeling, can be reasonably expected to result in a significant injury to the user.