

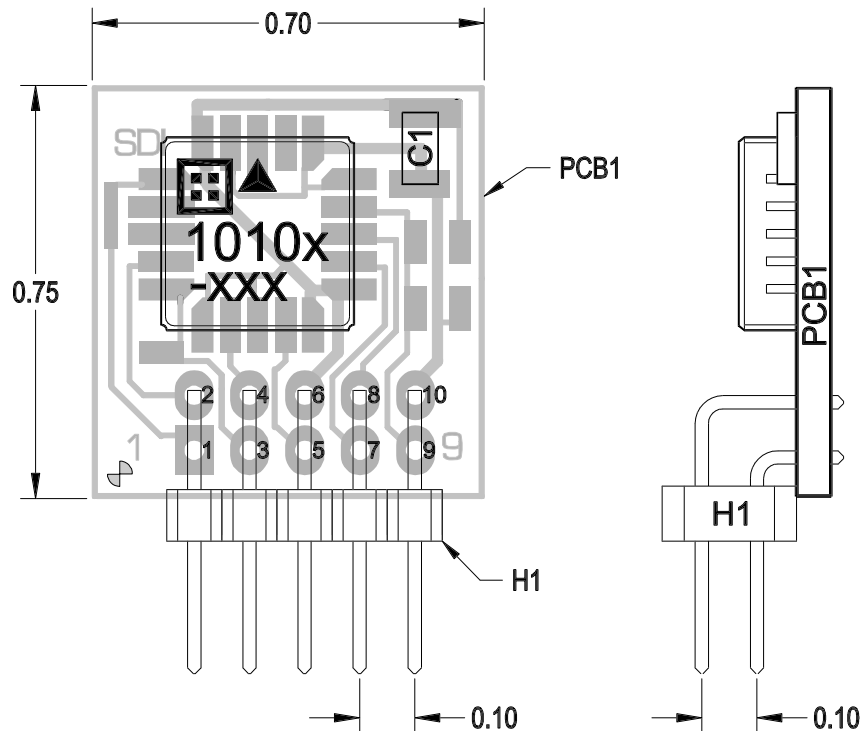

PARTS LIST

| QTY | REFERENCE DESIGNATION | PART NUMBER | PART DESCRIPTION |
|-----|-----------------------|----------------------|---|
| 1 | - | Model 1010L or 1010J | Model 1010 Accelerometer (Sold Separately) |
| 1 | PCB1 | 100-00023-01 | Printed Circuit Board |
| 1 | C1 | 753-00001-23 | Capacitor, Surface Mount Chip, Size 1205, 0.1uF |
| 1 | H1 | 702-00001-10 | Header, Right Angle, 2x5 Pins |



| HEADER PIN | SIGNAL NAME | SIGNAL DESCRIPTION |
|------------|-------------|--------------------------|
| 1 | DV | Deflection Voltage input |
| 2 | - | (not used) |
| 3 | CLK | Clock input |
| 4 | CNT | Count output |
| 5 | DIR | Direction output |
| 6 | VDD | +5V Power |
| 7 | CLK/2 | Clock+2 output |
| 8 | DIR | Direction not output |
| 9 | - | (not used) |
| 10 | GND | Ground |

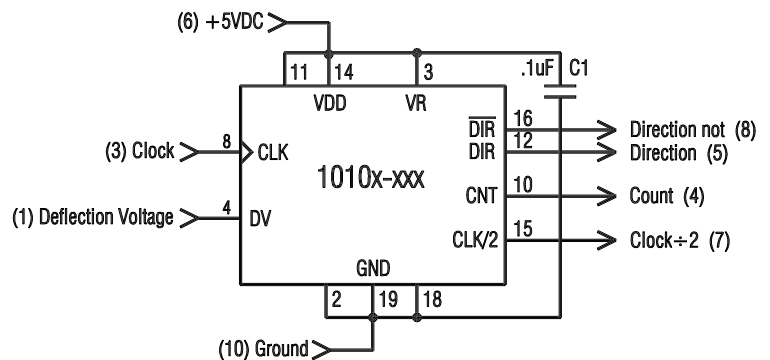

TB1010 & TB1210 SOLDER ASSEMBLY TIPS

Reflow using a hotplate is the preferred method for assembling the model TB1010 or TB1210 and Sn62 or Sn63 type solder is recommended. Hand soldering using a fine tipped soldering iron is possible but difficult without a steady hand and some form of visual magnification due to the small size of the connections. When using the hand solder iron method, it's best to purchase the J-Leaded version (1010J or 1210J) for easier visual inspection of the finished solder joints.

Pre-Tinning of Accelerometer Leads is Recommended: To prevent gold migration embrittlement of the solder joints, it is best to pre-tin the accelerometer leads. The solder bath method of pre-tinning is not recommended due to the high degree of heat the interior of the device gets subjected to which may cause permanent shifts in the bias and scale factor. Instead, we recommend tinning one lead at a time, to prevent excessive heating of the accelerometer, using a fine-tipped solder iron and solder wire.

Hotplate Attach Method using Solder Paste or Solder Wire: Apply solder to the circuit board's pads using Sn62 or Sn63 solder paste or pre-tin the pads using solder and a fine tipped soldering iron. If pre-tinning with an iron, apply flux to the tinned pads prior to placing the components. Place the accelerometer & C1 (R1 & R2 also for TB1210) in their proper positions onto the pasted or tinned pads then place the entire assembly onto a hotplate that has been pre-heated to around 200°C. Leave on hotplate only long enough for the solder to flow on all pads (**DO NOT OVERHEAT!**)

Solder Iron Attach Method using Solder Paste: Apply solder paste to the circuit board's pads where the accelerometer & C1 (R1 & R2 also for TB1210) will be attached. Place the components in their proper positions onto their pasted pads. Press gently on the top of the accelerometer with an appropriate tool to keep it from moving and heat one of the corner pads, then an opposite corner pad with the soldering iron. Make sure the accelerometer is positioned so all 20 of its connections are centered on the board's pads. Once the two opposite corner pads are soldered, the part is secure to the board and you can work your way around soldering the remaining 18 connections. Allow the accelerometer to cool in between soldering each pin to prevent overheating. Solder the remaining passive component(s) to the board one at a time by pressing on their tops with an appropriate tool and applying heat to each pad. Once the part has seated on its tinned pad, solder the other end of the part to the board.

Solder Iron Attach Method using Solder Wire: Solder pre-tin two opposite corner pads on the circuit board where the accelerometer will be attached and one of the two pads for C1 (R1 & R2 also for TB1210). Place the accelerometer in its proper position onto the board. Press gently on the top of the accelerometer and heat one of the corner pads that was tinned and the part will drop down through the solder and seat on the board. Do the same at the opposite corner pad that was tinned. Make sure the accelerometer is positioned so all 20 of its connections are centered on the board's pads. Once the two opposite corner pads are soldered, the part is secure to the board and you can work your way around soldering the remaining 18 connections. Allow the accelerometer to cool in between soldering each pin to prevent overheating. Solder the remaining component(s) by gently pressing on their top(s) with an appropriate tool and applying heat to the tinned pad end only. Once the part has seated on its tinned pad, solder the other end of the part to the board.