

RoHS Compliant Product
A suffix of "-C" specifies halogen free

DESCRIPTION

The SSE55N03 provide the designer with the best combination of fast switching, ruggedized device design, low on-resistance and cost-effectiveness. The through-hole version (TO-220) is available for low-profile applications and suited for low voltage applications such as DC/DC converters.

FEATURES

- Dynamic dv/dt Rating
- Simple Drive Requirement
- Repetitive Avalanche Rated
- Fast Switching

PACKAGE DIMENSIONS

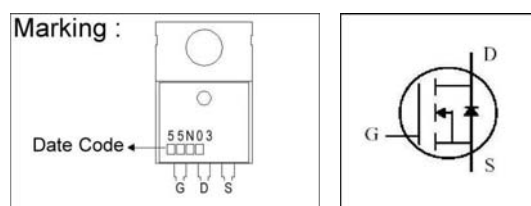
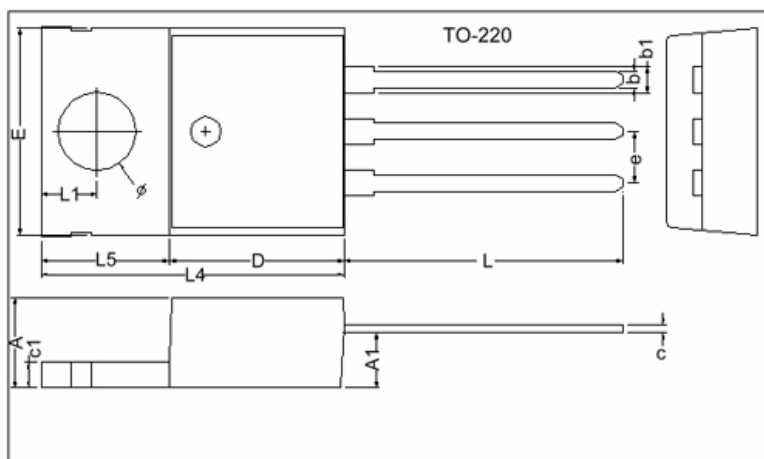

REF.	Millimeter		REF.	Millimeter	
	Min.	Max.		Min.	Max.
A	4.40	4.80	c1	1.25	1.45
b	0.76	1.00	b1	1.17	1.47
c	0.36	0.50	L	13.25	14.25
D	8.60	9.00	e	2.54 REF.	
E	9.80	10.4	L1	2.60	2.89
L4	14.7	15.3	\varnothing	3.71	3.96
L5	6.20	6.60	A1	2.60	2.80

ABSOLUTE MAXIMUM RATINGS

Parameter	Symbol	Ratings	Unit
Drain-Source Voltage	V_{DS}	25	V
Gate-Source Voltage	V_{GS}	± 20	V
Drain Current, $V_{GS}@ 10V$	$I_D @ T_a=25^\circ C$	55	A
Drain Current, $V_{GS}@ 10V$	$I_D @ T_a=100^\circ C$	35	A
Pulsed Drain Current ¹	I_{DM}	215	A
Total Power Dissipation	$P_D @ T_c=25^\circ C$	62.5	W
Linear Derating Factor		0.5	W/ $^\circ C$
Single Pulse Avalanche Energy ²	E_{AS}	240	mJ
Single Pulse Avalanche Current	I_{AS}	31	A
Operating Junction and Storage Temperature Range	T_j, T_{stg}	-55 ~ +150	$^\circ C$

THERMAL DATA

Parameter	Symbol	Value	Unit
Thermal Resistance Junction-case Max.	$R_{\theta j-case}$	2.0	$^\circ C/W$
Thermal Resistance Junction-ambient Max.	$R_{\theta j-amb}$	62	$^\circ C/W$

ELECTRICAL CHARACTERISTICS (T_j = 25°C unless otherwise specified)

Parameter	Symbol	Min.	Typ.	Max.	Unit	Test Conditions
Drain-Source Breakdown Voltage	BV_{DSS}	25	-	-	V	$V_{GS}=0, I_D=250\mu A$
Breakdown Voltage Temp. Coefficient	$\Delta BV_{DSS}/\Delta T_j$	-	0.037	-	V/°C	Reference to 25°C, $I_D=1mA$
Gate Threshold Voltage	$V_{GS(th)}$	1.0	-	3.0	V	$V_{DS}=V_{GS}, I_D=250\mu A$
Forward Transconductance	g_{fs}	-	30	-	S	$V_{DS}=10V, I_D=28A$
Gate-Source Leakage Current	I_{GSS}	-	-	±100	nA	$V_{GS}= \pm 20V$
Drain-Source Leakage Current(T _j =25°C)	I_{DSS}	-	-	1	uA	$V_{DS}=25V, V_{GS}=0$
Drain-Source Leakage Current(T _j =150°C)		-	-	25	uA	$V_{DS}=20V, V_{GS}=0$
Static Drain-Source On-Resistance ³	$R_{DS(ON)}$	-	4.5	6	m Ω	$V_{GS}=10V, I_D=30A$
		-	7	9		$V_{GS}=4.5V, I_D=30A$
Total Gate Charge ³	Q_g	-	16.8	-	nC	$I_D=28A$ $V_{DS}=20V$ $V_{GS}=5V$
Gate-Source Charge	Q_{gs}	-	6	-		
Gate-Drain ("Miller") Charge	Q_{gd}	-	4.9	-		
Turn-on Delay Time ³	$T_{d(on)}$	-	15.1	-	ns	$V_{DS}=15V$ $I_D=28A$ $V_{GS}=10V$ $R_G=3.3\Omega$ $R_D=0.53\Omega$
Rise Time	T_r	-	4	-		
Turn-off Delay Time	$T_{d(off)}$	-	45.2	-		
Fall Time	T_f	-	7.6	-		
Input Capacitance	C_{iss}	-	2326	-	pF	$V_{GS}=0V$ $V_{DS}=25V$ $f=1.0MHz$
Output Capacitance	C_{oss}	-	331	-		
Reverse Transfer Capacitance	C_{rss}	-	174	-		

SOURCE-DRAIN DIODE

Parameter	Symbol	Min.	Typ.	Max.	Unit	Test Conditions
Forward On Voltage ²	V_{SD}	-	-	1.5	V	$I_S=20A, V_{GS}=0V, T_j=25^\circ C$
Reverse Recovery Charge	I_S	-	-	55	A	$V_D= V_G=0V, V_S=1.5V$

- Notes: 1. Pulse width limited by safe operating area.
2. Staring T_j=25°C, V_{DD}=20V, L=0.1mH, R_G=25 Ω , I_{AS}=10A.
3. Pulse width ≤ 300us, duty cycle ≤ 2%.

CHARACTERISTIC CURVE

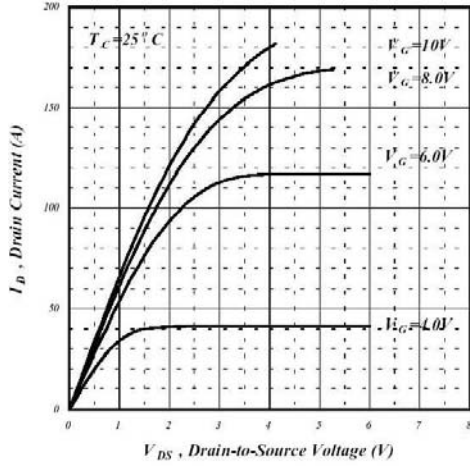

Fig 1. Typical Output Characteristics

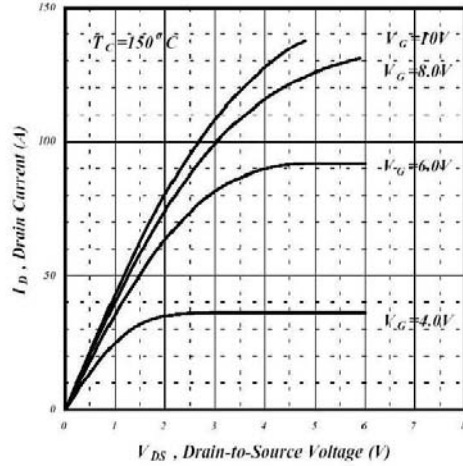

Fig 2. Typical Output Characteristics

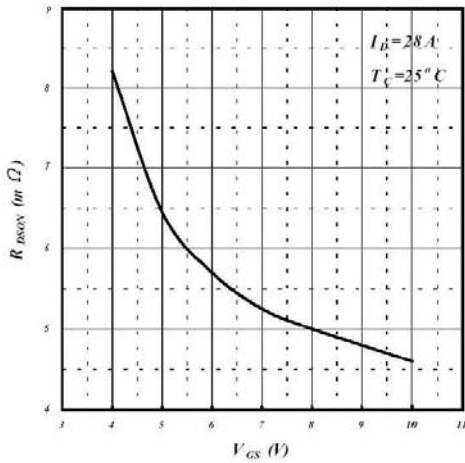

Fig 3. On-Resistance vs. Gate Voltage

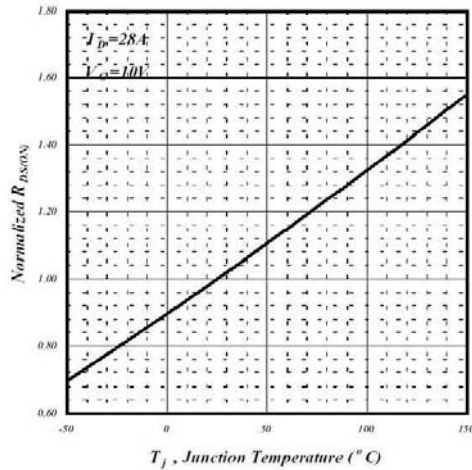

Fig 4. Normalized On-Resistance vs. Junction Temperature

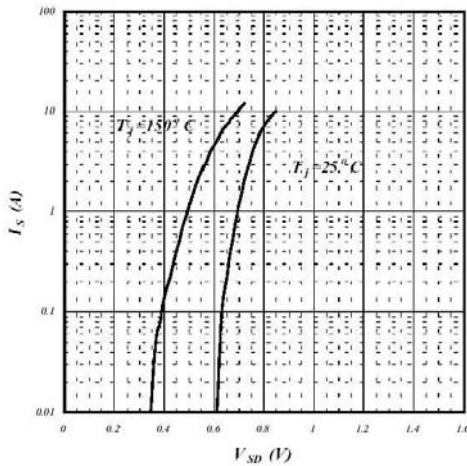

Fig 5. Forward Characteristics of Reverse Diode

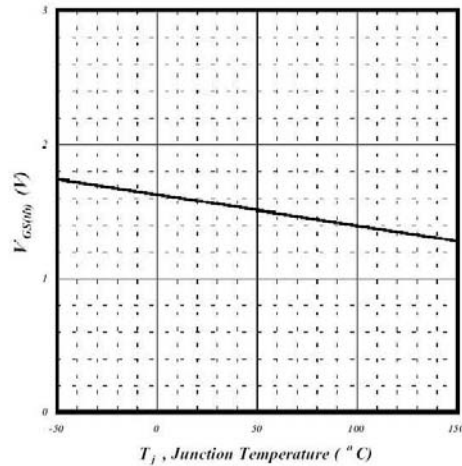

Fig 6. Gate Threshold Voltage vs. Junction Temperature

CHARACTERISTIC CURVE

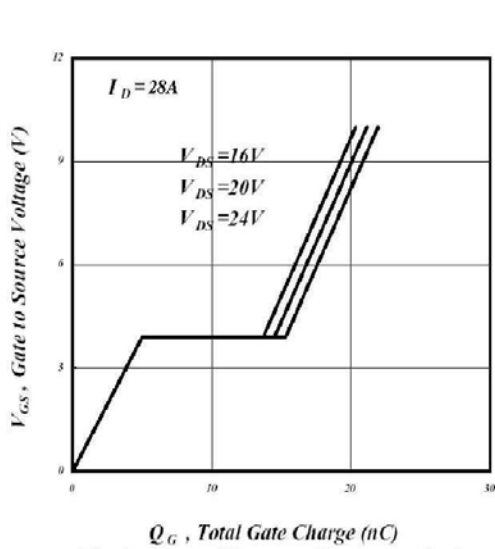

Fig 7. Gate Charge Characteristics

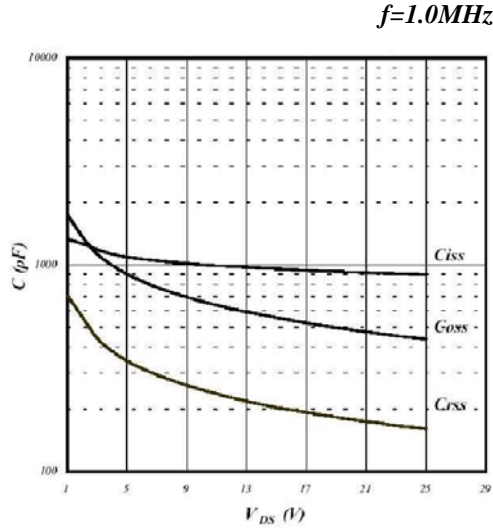

Fig 8. Typical Capacitance Characteristics

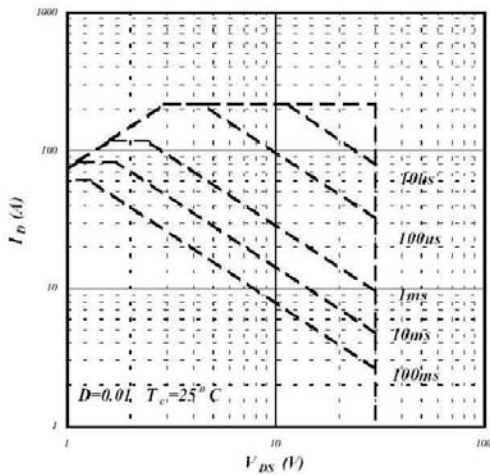

Fig 9. Maximum Safe Operating Area

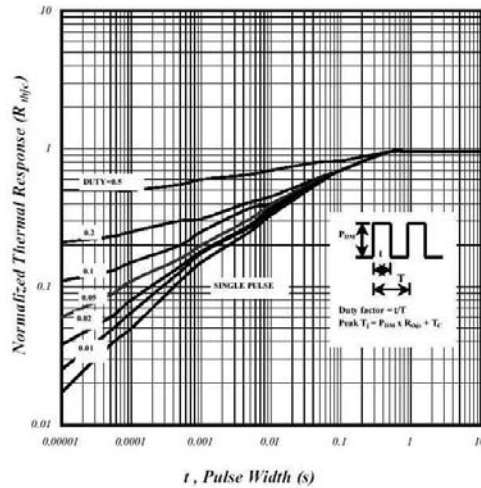

Fig 10. Effective Transient Thermal Impedance

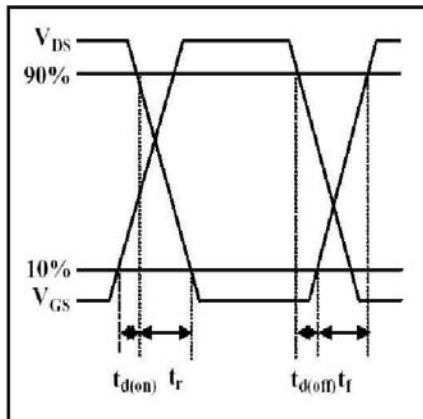

Fig 11. Switching Time Waveform

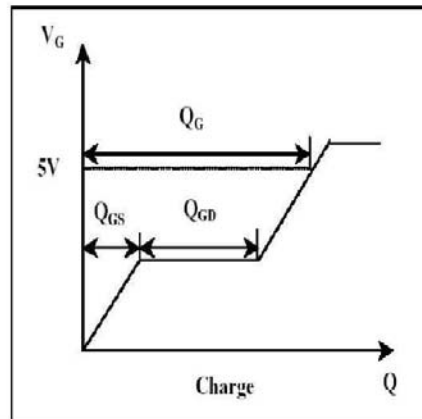

Fig 12. Gate Charge Waveform