

Silicon NPN Power Transistors

BU2520D

DESCRIPTION

- With TO-3PN package
- High voltage,high speed
- Built-in damper diode

APPLICATIONS

- For use in horizontal deflection circuits of large screen colour TV receivers.

PINNING

PIN	DESCRIPTION
1	Base
2	Collector;connected to mounting base
3	Emitter

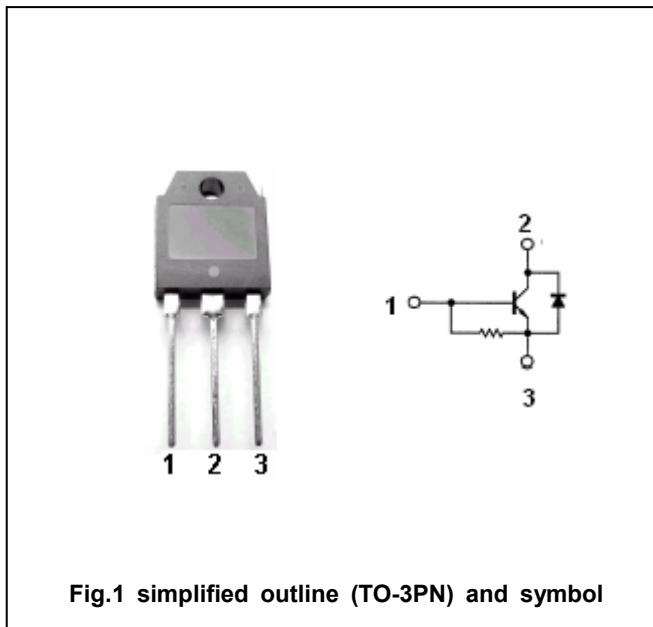

Fig.1 simplified outline (TO-3PN) and symbol

Absolute maximum ratings (Ta=25°C)

SYMBOL	PARAMETER	CONDITIONS	VALUE	UNIT
V _{CBO}	Collector-base voltage	Open emitter	1500	V
V _{CEO}	Collector-emitter voltage	Open base	800	V
V _{EBO}	Emitter-base voltage	Open collector	7.5	V
I _C	Collector current (DC)		10	A
I _{CM}	Collector current-peak		25	A
I _B	Base current(DC)		6	A
I _{BM}	Base current-peak		9	A
P _C	Collector power dissipation	T _C =25°C	125	W
T _j	Junction temperature		150	°C
T _{stg}	Storage temperature		-65~150	°C

Silicon NPN Power Transistors

BU2520D

CHARACTERISTICS

T_j=25°C unless otherwise specified

SYMBOL	PARAMETER	CONDITIONS	MIN	TYP.	MAX	UNIT
V _{CEO(SUS)}	Collector-emitter sustaining voltage	I _C =100mA ; I _B =0, L=25mH	800			V
V _{(BR)EBO}	Emitter-base breakdown voltage	I _B =600mA; I _C =0	7.5	13.5		V
V _{CEsat}	Collector-emitter saturation voltage	I _C =6A; I _B =1.2A			5.0	V
V _{BEsat}	Base-emitter saturation voltage	I _C =6A; I _B =1.2A			1.3	V
I _{CES}	Collector cut-off current	V _{CE} =rated V _{CE} ; V _{BE} =0 T _j =125°C			1.0 2.0	mA
I _{EBO}	Emitter cut-off current	V _{EB} =7.5V; I _C =0	100		300	mA
h _{FE-1}	DC current gain	I _C =1A ; V _{CE} =5V			23	
h _{FE-2}	DC current gain	I _C =6A ; V _{CE} =5V	5	7	10	
V _F	Diode forward voltage	I _F =6A			2.2	V
C _C	Collector capacitance	I _E =0 ; V _{CB} =10V; f=1MHz		115		pF

Silicon NPN Power Transistors

BU2520D

PACKAGE OUTLINE

