

High-Voltage Switching Applications

2SC3646

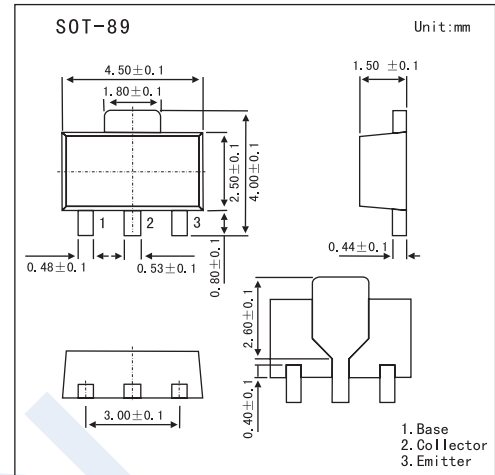

■ Features

- Adoption of FBET, MBIT Processes
- High Breakdown Voltage and Large Current Capacity
- Fast Switching Time

■ Absolute Maximum Ratings Ta = 25°C

Parameter	Symbol	Rating	Unit
Collector-Base Voltage	V _{CB0}	120	V
Collector-Emitter Voltage	V _{CEO}	100	V
Emitter-Base Voltage	V _{EBO}	6	V
Collector Current	I _C	1	A
Collector Current (Pulse)	I _{CP}	2	A
Collector Power Dissipation	P _C	500	mW
	P _C *	1.3	W
Junction temperature	T _j	150	°C
Storage temperature Range	T _{stg}	-55 to +150	°C

* Mounted on ceramic board (250 mm² x 0.8 mm)

■ Electrical Characteristics Ta = 25°C

Parameter	Symbol	Testconditions	Min	Typ	Max	Unit
Collector Cut-off Current	I _{CBO}	V _{CB} = 100V, I _E = 0			100	nA
Emitter Cut-off Current	I _{EBO}	V _{EB} = 4V, I _C = 0			100	nA
Collector-Base Breakdown Voltage	V _{(BR)CBO}	I _C = 10uA, I _E = 0	120			V
Collector-Emitter Breakdown Voltage	V _{(BR)CEO}	I _C = 1mA, R _{BE} = ∞	100			V
Emitter-Base Breakdown Voltage	V _{(BR)EBO}	I _E = 10uA, I _C = 0	6			V
DC Current Gain	h _{FE}	V _{CE} = 5V, I _C = 100mA	100		400	
Collector-Emitter Saturation Voltage	V _{CE(sat)}	I _C = 400mA, I _B = 40mA		0.2	0.6	V
Base-Emitter Saturation Voltage	V _{BE(sat)}	I _C = 400mA, I _B = 40mA		0.85	1.2	V
Gain-Bandwidth Product	f _T	V _{CE} = 10V, I _C = 100mA		120		MHz
Collector Output Capacitance	C _{ob}	V _{CB} = 10V, I _E = 0, f = 1MHz		13		pF
Turn-On Time	t _{on}	See Test Circuit.		80		ns
Storage Time	t _{stg}			700		
Fall Time	t _f			40		

2SC3646

■ Test Circuit

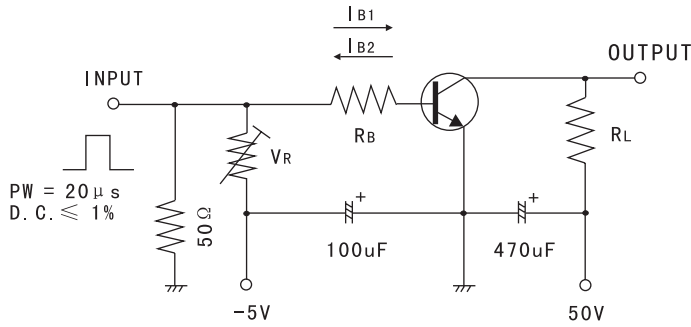

$10I_{B1} = -10I_{B2} = I_C = 400\text{mA}$
 (For PNP, the polarity is reversed.)

■ hFE Classification

Marking	CB		
Rank	R	S	T
hFE	100 ~ 200	140 ~ 280	200 ~ 400

■ Electrical Characteristics Curves

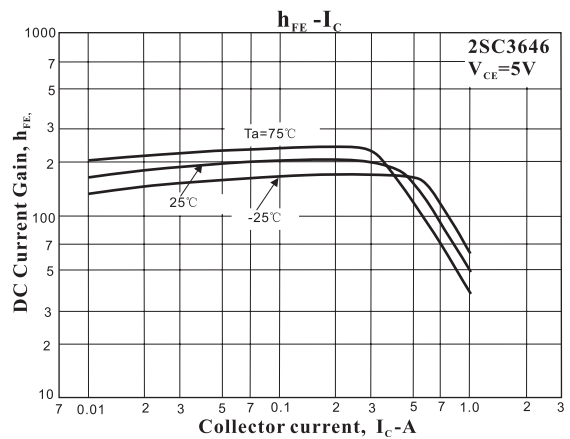
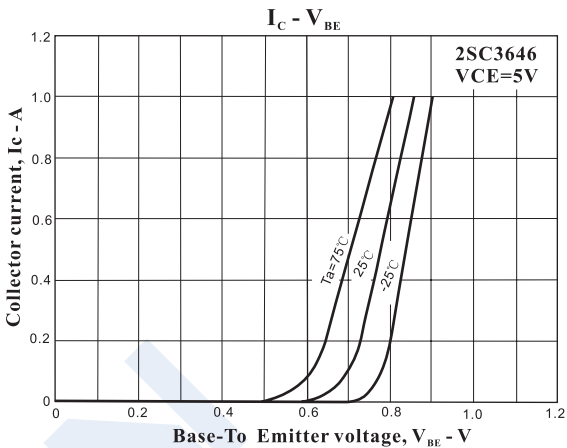
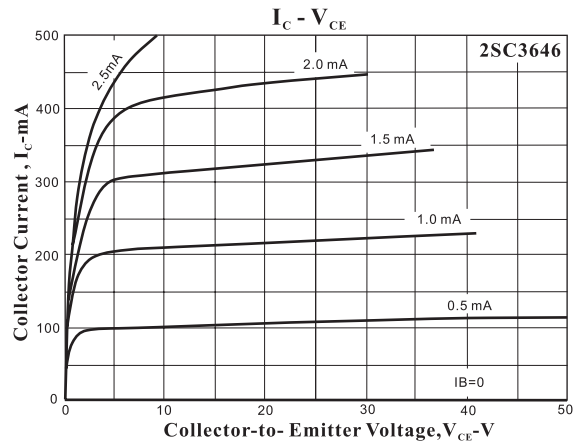
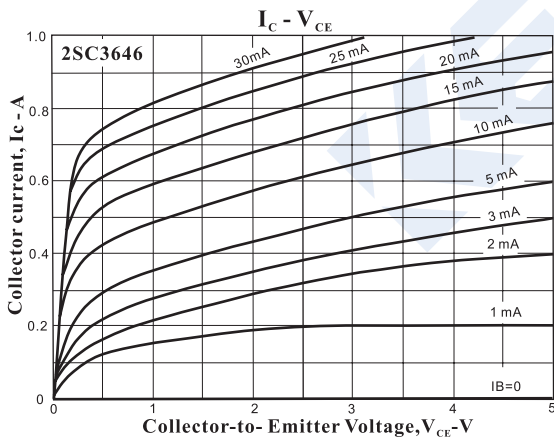

2SC3646

