

Data Sheet



Description

The Avago Technologies PLCC-4 family of SMT LEDs is packaged in the industry standard PLCC-4 Package and is an extension of our PLCC-2 SMT LEDs. The product is able to dissipate heat more efficiently compared to the conventional PLCC-2 SMT LEDs. In proportion to the increase in driving current, this family of LEDs is able to produce higher light output compared to the conventional PLCC-2 SMT LEDs.

These SMT LEDs have higher reliability and better performance and are designed to work under a wide range of environment conditions. This higher reliability makes them suitable for use in harsh conditions such as the Interior Automotive, Electronics Signs and Signals and Office automation and Industrial applications.

The super wide viewing angle at 120° makes these LEDs ideally suited for panel, push button, or general backlighting in automotive interior, office equipment, industrial equipment, and home appliances. The flat top emitting surface makes it easy for these LEDs to mate with light pipes. With the built-in reflector pushing up the intensity of the light output, these LEDs are also suitable to be used as LED pixels in interior electronic signs. These super high brightness LEDs can be used in localized area ambient lighting in applications such as vanity mirror light, cabin light, and car door puddle light. The white color backlighting is suitable to backlight color LCD screens in applications such as GPS (global positioning system) screens in cars.

To facilitate easy pick and place assembly, the LEDs are packed in EIA-compliant tape and reel. Every reel will be shipped in single intensity and color bin, to provide close uniformity.

These LEDs are compatible with IR solder reflow process. Due to the high reliability feature of these products, they can also be mounted using through-the-wave soldering process.

Features

- Industry Standard PLCC-4
- High reliability LED package
- High brightness using InGaN dice technologies
- High optical efficiency
- Super wide viewing angle at 120°
- Available in 8mm carrier tape on 7-inch reel
- Tight White color Binning
- Compatible with both IR and TTW soldering process

Applications

- Interior automotive
 - Instrument panel backlighting
 - Central console backlighting
 - Cabin lighting
 - Navigation and audio system
 - Dome lighting
 - Push button backlighting
- Electronic signs and signals
 - Variable message sign
 - Garden lighting
- Office automation, home appliances, industrial equipment
 - Front panel backlighting
 - Push button backlighting

CAUTION: HSMW-A40x-xxxxx LEDs are Class 2 ESD sensitive. Please observe appropriate precautions during handling and processing. Refer to Avago Technologies Application Note AN-1142 for additional details

Package Dimensions

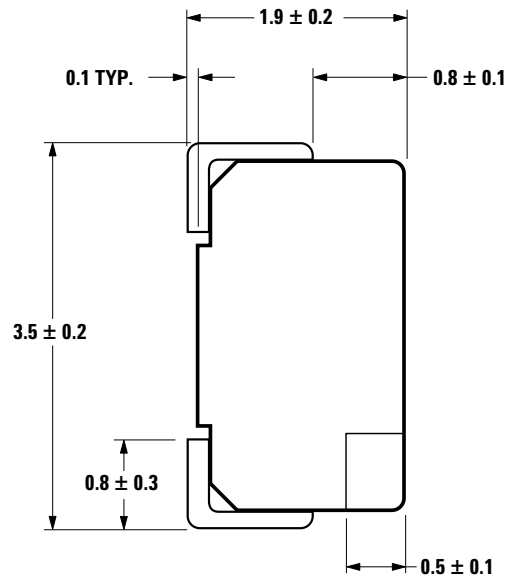
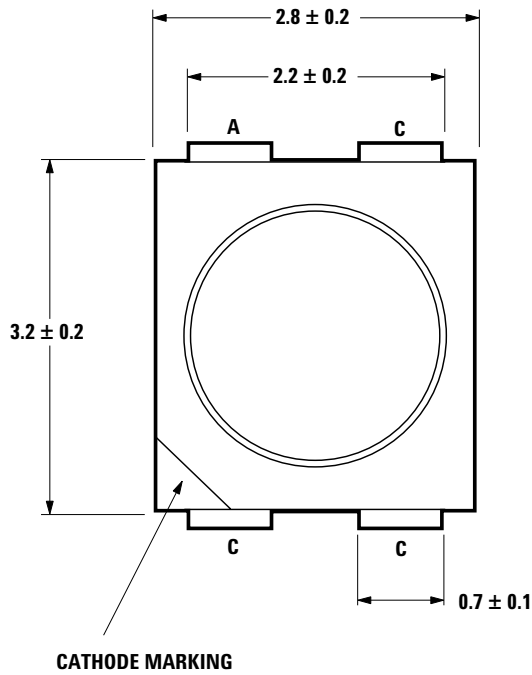

NOTE: ALL DIMENSIONS IN mm.

Device Selection Guide

Color	Part Number	Min. I_V (mcd)	Typ. I_V (mcd)	Max. I_V (mcd)	Test Current (mA)	Dice Technology
White	HSMW-A400-U00M2	450.00	700.00	-	30	InGaN

Notes:

1. The luminous intensity I_V is measured at the mechanical axis of the lamp package. The actual peak of the spatial radiation pattern may not be aligned with this axis.
2. I_V tolerance = $\pm 12\%$.

Absolute Maximum Ratings ($T_A=25^\circ\text{C}$)

Parameters	HSMW
DC Forward Current [1]	30 mA
Peak Forward Current [2]	100 mA
Power Dissipation	114 mW
Reverse Voltage	5 V
Junction Temperature	110 °C
Operating Temperature	- 40 °C to + 100 °C
Storage Temperature	- 40 °C to + 100 °C

Notes:

1. Derate linearly as shown in Figure 3
2. Duty factor = 10%, Frequency = 1kHz

Optical Characteristics ($T_A = 25\text{ }^\circ\text{C}$)

Color	Part Number	Dice Technology	Typical Chromaticity Coordinates ^[1]		Viewing Angle $2\theta_{1/2}$ ^[2] (Degrees)	Luminous Efficacy η_V ^[3] (lm/W)	Luminous Intensity / Total Flux I_V (mcd) / Φ_V (lm)
			x	y	Typ.	Typ.	Typ.
White	HSMW-A400	InGaN	0.31	0.31	120	260	0.45

Notes:

1. The chromaticity coordinates are derived from the CIE 1931 Chromaticity Diagram and represent the perceived color of the device.
2. $\theta_{1/2}$ is the off-axis angle where the luminous intensity is $1/2$ the peak intensity.
3. Radiant intensity, I_e in watts / steradian, may be calculated from the equation $I_e = I_V / \eta_V$, where I_V is the luminous intensity in candelas and η_V is the luminous efficacy in lumens / watt.

Electrical Characteristics ($T_A = 25\text{ }^\circ\text{C}$)

Part Number	Forward Voltage V_F (Volts) @ $I_F = 20\text{ mA}$		Reverse Voltage V_R @ $100\text{ }\mu\text{A}$	Reverse Voltage V_R @ $10\text{ }\mu\text{A}$
	Typ.	Max.	Min.	Min.
HSMW	3.8	4.6	-	5

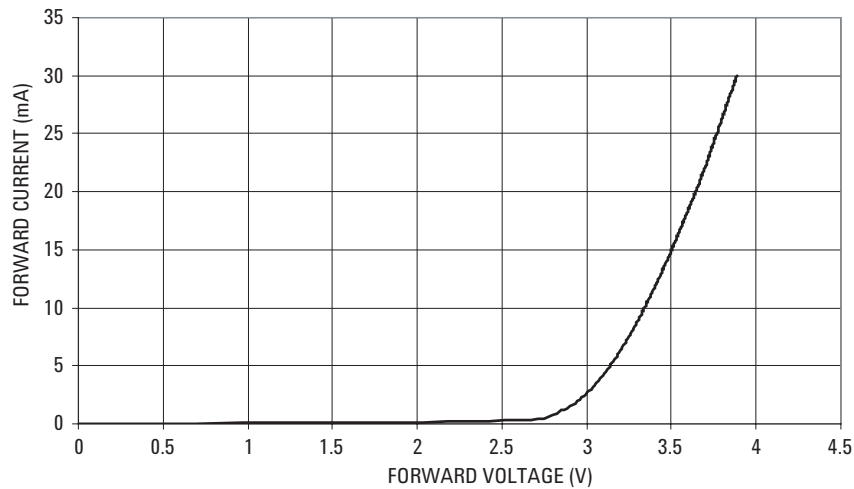

Figure 1. Forward Current Vs. Forward Voltage.

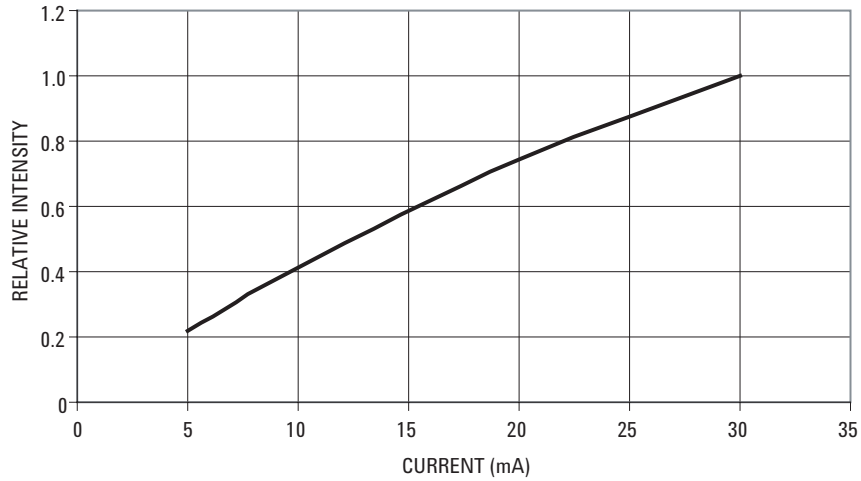

Figure 2. Relative Intensity Vs. Forward Current

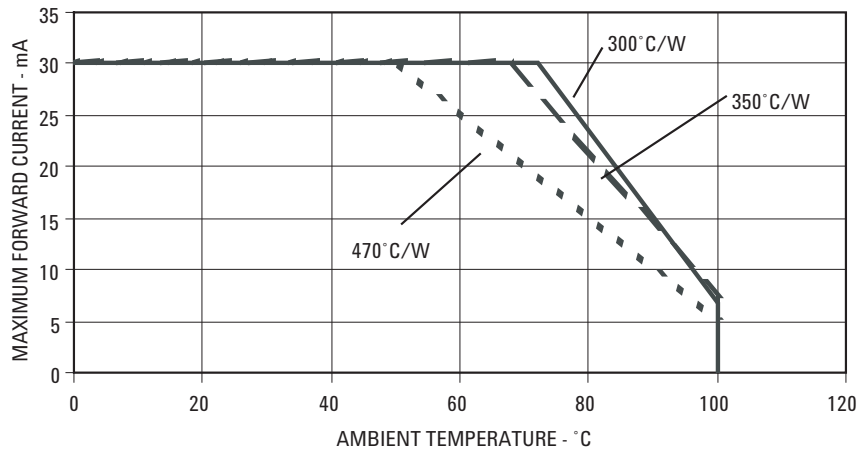

Figure 3. Maximum Forward Current Vs. Ambient Temperature. Derated Based on $T_{JMAX} = 110^{\circ}C$.

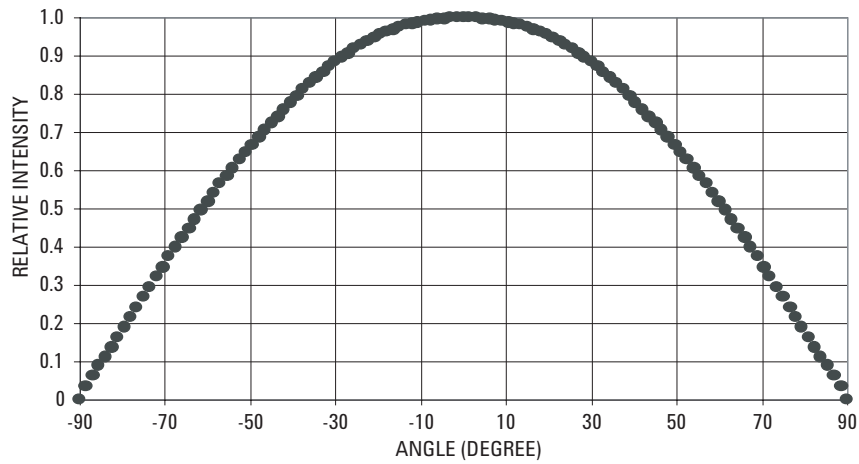

Figure 4. Radiation Pattern

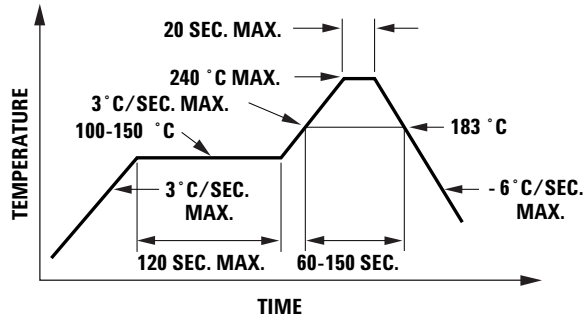
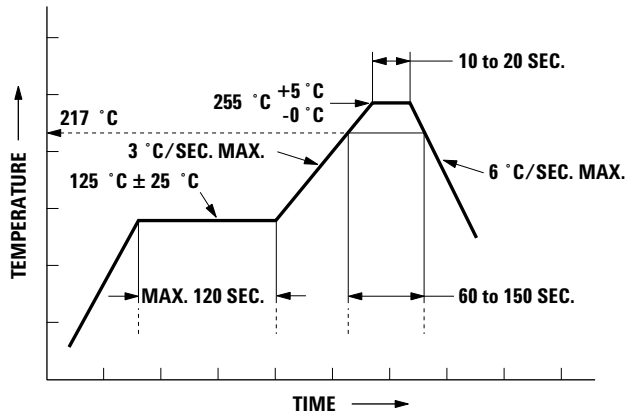

Figure 5a. Recommended SnPb Reflow Soldering Profile.



* THE TIME FROM 25 °C TO PEAK TEMPERATURE = 6 MINUTES MAX.

Figure 5b. Recommended Pb-free Reflow Soldering Profile.

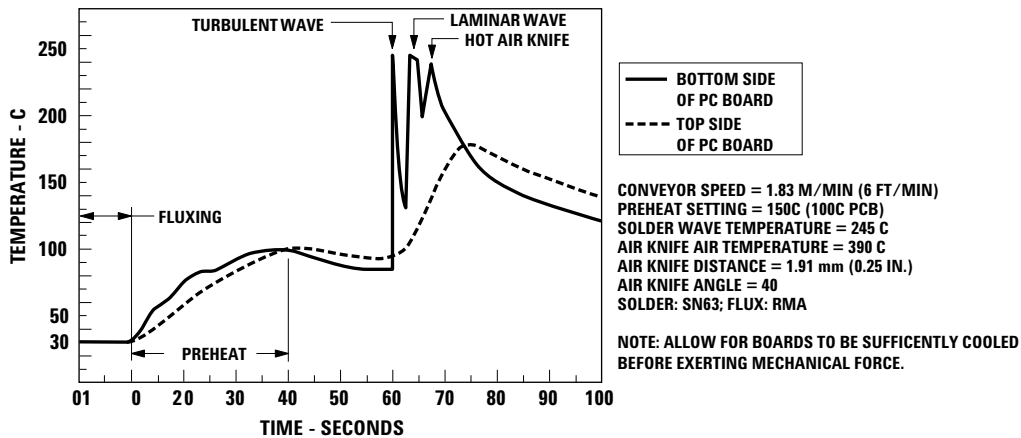

Figure 6. Recommended Wave Soldering Profile.

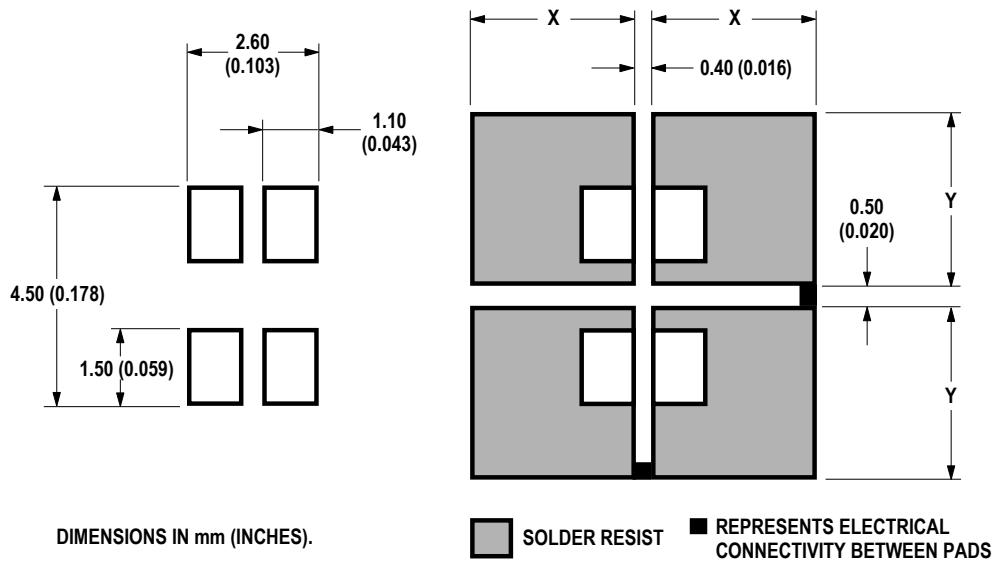

Figure 7a. Recommended Soldering Pad Pattern.

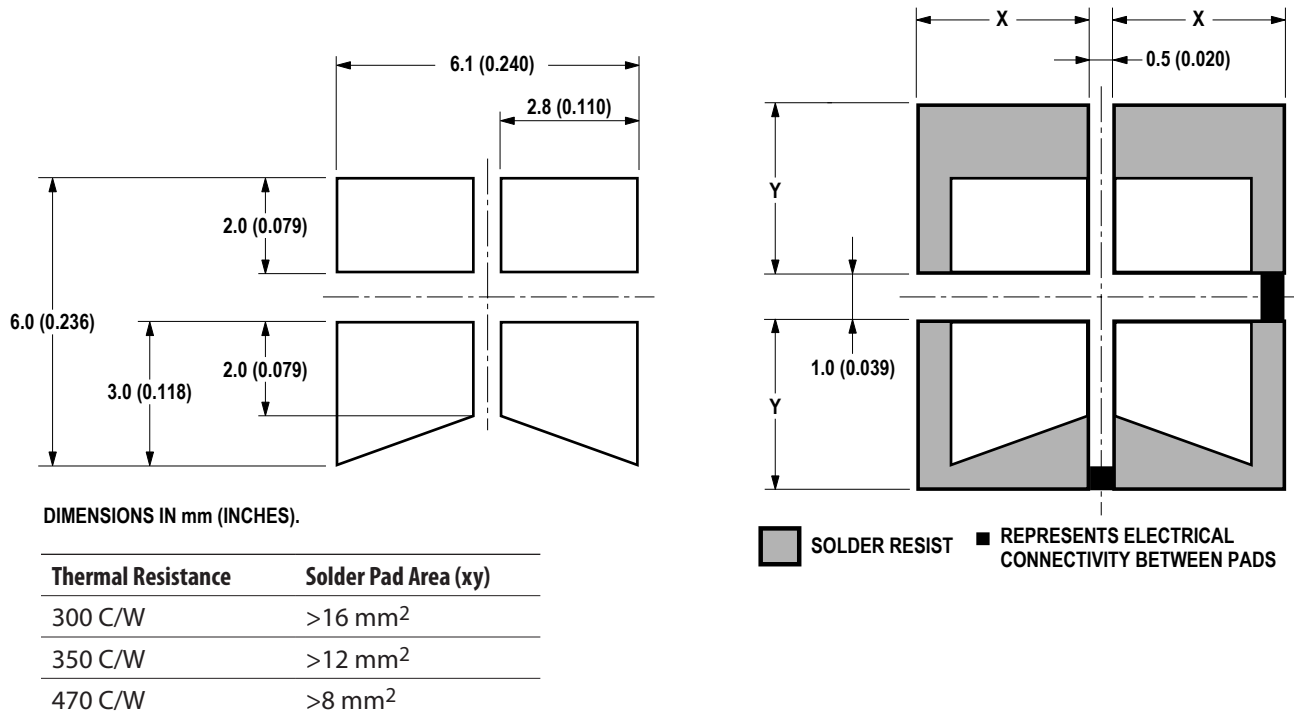

Figure 7b. Recommended soldering pad pattern (TTW).

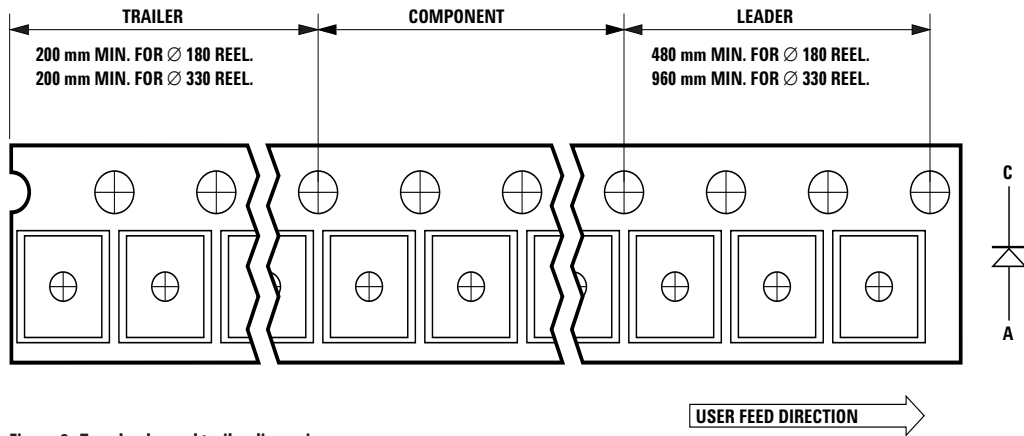

Figure 8. Tape leader and trailer dimensions.

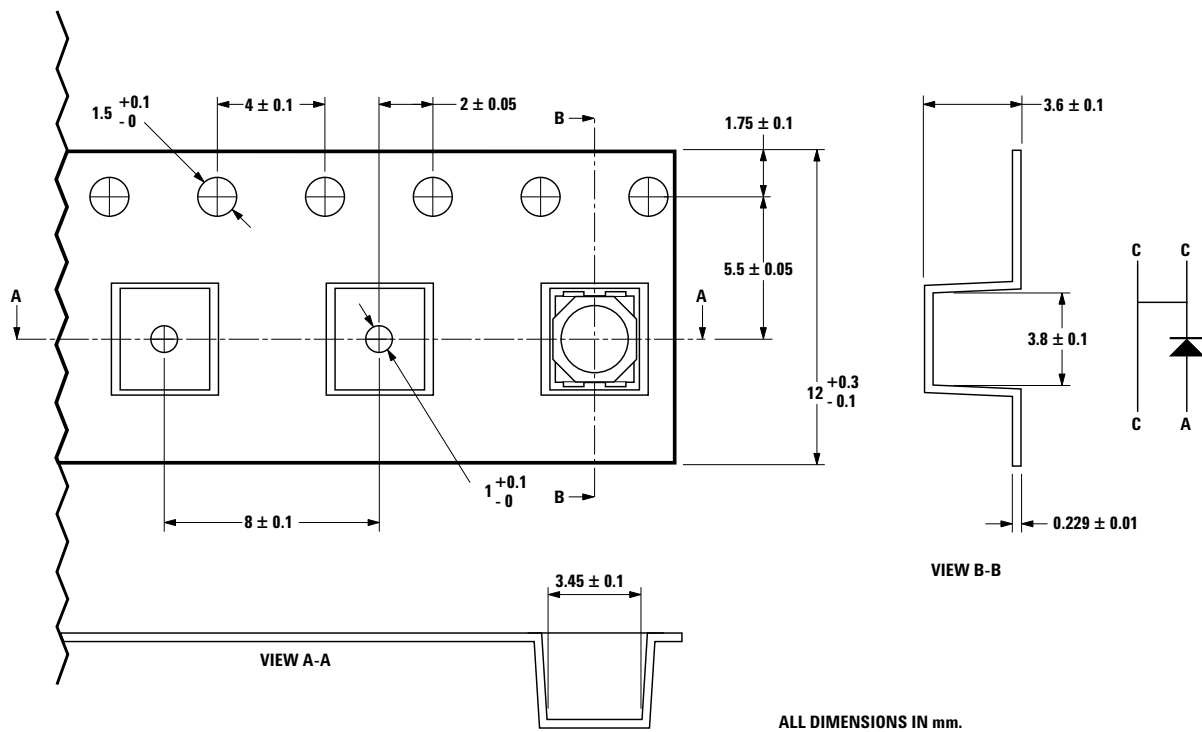

Figure 9. Tape Dimensions.

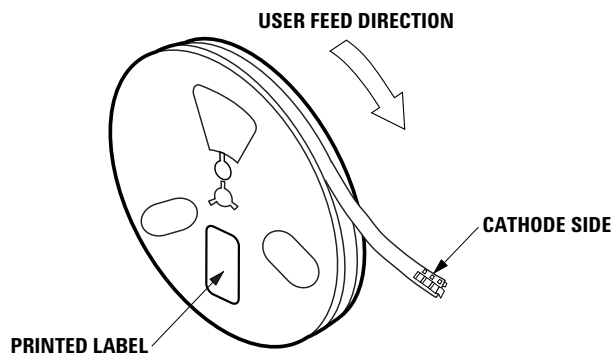

Figure 10. Reeling Orientation.

Moisture Sensitivity

This product is qualified as Moisture Sensitive Level 2a per Jedec J-STD-020. Precautions when handling this moisture sensitive product is important to ensure the reliability of the product. Do refer to Avago Application Note AN5305 Handling of Moisture Sensitive Surface Mount Devices for details.

A. Storage before use

- Unopen moisture barrier bag (MBB) can be stored at <40°C/90%RH for 12 months. If the actual shelf life has exceeded 12 months and the HIC indicates that baking is not required, then it is safe to reflow the LEDs per the original MSL rating.
- It is not recommended to open the MBB prior to assembly (e.g. for IQC).

B. Control after opening the MBB

- The humidity indicator card (HIC) shall be read immediately upon opening of MBB.
- The LEDs must be kept at <30°C / 60%RH at all time and all high temperature related process including soldering, curing or rework need to be completed within 672 hours.

C. Control for unfinished reel

- For any unuse LEDs, they need to be stored in sealed MBB with desiccant or desiccator at <5%RH.

D. Control of assembled boards

- If the PCB soldered with the LEDs is to be subjected to other high temperature processes, the PCB need to be stored in sealed MBB with desiccant or desiccator at <5%RH to ensure no LEDs have exceeded their floor life of 672 hours.

E. Baking is required if:

- "10%" or "15%" HIC indicator turns pink.
- The LEDs are exposed to condition of >30°C / 60% RH at any time.
- The LEDs floor life exceeded 672 hours.

Recommended baking condition: 60±5°C for 20 hours.

Intensity Bin Select (X₅X₆)

Individual reel will contain parts from one half bin only

X ₅	Min l _y Bin
X ₆	
0	Full Distribution
3	3 half bins starting from X ₅ 1
4	4 half bins starting from X ₅ 1
5	5 half bins starting from X ₅ 1
7	3 half bins starting from X ₅ 2
8	4 half bins starting from X ₅ 2
9	5 half bins starting from X ₅ 2

Intensity Bin Limits

Bin ID	Min. (mcd)	Max. (mcd)
S1	180.00	224.00
S2	224.00	285.00
T1	285.00	355.00
T2	355.00	450.00
U1	450.00	560.00
U2	560.00	715.00
V1	715.00	900.00
V2	900.00	1125.00
W1	1125.00	1400.00
W2	1400.00	1800.00

Tolerance of each bin limit = ± 12%

Color Bin Select (X₇)

Individual reel will contain parts from one full bin only.

X ₇	
0	Full Distribution
Z	A and B only
Y	B and C only
W	C and D only
V	D and E only
U	E and F only
Q	A, B and C only
P	B, C and D only
N	C, D and E only
M	D, E and F only
1	A, B, C and D only
3	B, C, D and E only
4	C, D, E and F only
5	A, B, C, D and E only
6	B, C, D, E, and F only

Color Bin Limits

Bin ID	Limits (Chromaticity Coordinates)
A	X 0.352 0.365 0.365 0.352
	Y 0.377 0.395 0.360 0.341
B	X 0.340 0.352 0.352 0.340
	Y 0.360 0.377 0.341 0.325
C	X 0.327 0.340 0.340 0.327
	Y 0.342 0.360 0.325 0.306
D	X 0.315 0.327 0.327 0.315
	Y 0.325 0.342 0.306 0.290
E	X 0.302 0.315 0.315 0.302
	Y 0.307 0.325 0.290 0.271
F	X 0.290 0.302 0.302 0.290
	Y 0.290 0.307 0.271 0.255

Tolerance of each bin limit = ± 0.02

Packaging Option (X₈X₉)

Option	Test Current	Package Type	Reel Size
M2	30 mA	Top Mount	7 inch

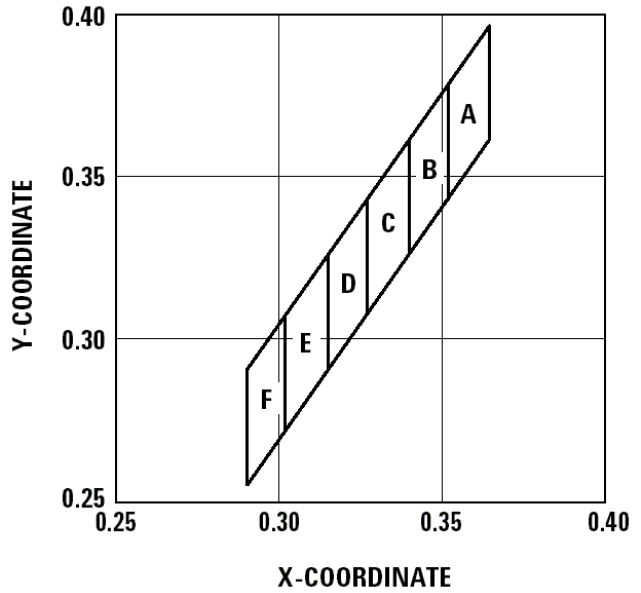

For product information and a complete list of distributors, please go to our web site: www.avagotech.com

Avago, Avago Technologies, and the A logo are trademarks of Avago Technologies, Limited in the United States and other countries. Data subject to change. Copyright © 2007 Avago Technologies Limited. All rights reserved. Obsoletes AV01-0435EN AV02-0497EN - August 29, 2007

