

7.4 x 3.4 x 1.8 mm SMD CERAMIC RESONATOR

AWSZT



7.4 x 3.4 x 1.8 mm

AWSZT-MGD

Pb in ceramic
(exempt per RoHS 2002/95/EC Annex (7))

RoHS
Compliant

FEATURES:

- Low resonant impedance
- 240°C peak reflow capable
- Low cost

APPLICATIONS:

- Remote controls, Microprocessor clocks, Mobile phones, DVD & CD-Roms, Electric appliances, Industrial controllers
- Consumer electronics

ELECTRICAL CHARACTERISTICS:

Item	Requirement
Frequency Range	1.84MHz to 8.00MHz
Resonant Impedance	See Table 2.1
Frequency Tolerance	± 0.5%
Frequency Stability	±0.3% max. (-25°C to +85°C)
Withstanding Voltage	50V (DC , 1 min)
Rating Voltage	
(1) D.C. Voltage	6 V.D.C. max
(2) A.C. Voltage	15 Vp-p. max
Load Capacitance	30pF ±20% (C1=C2)
Insulation Resistance	100MΩ min. (10V, 1min)
Operation Temperature	-25°C to +85°C
Storage Temperature	-55°C to +85°C
Aging Rate (Fosc)	±0.3% max. (10 years)

Table 2.1

Frequency Range (MHz)	Resonant Impedance (Ro)(Ω)
1.84 MHz - 2.99 MHz	100 max
3.00 MHz - 3.49 MHz	50 max
3.50 MHz - 8.00 MHz	30 max

TEST CONDITION AND TEST CIRCUIT:

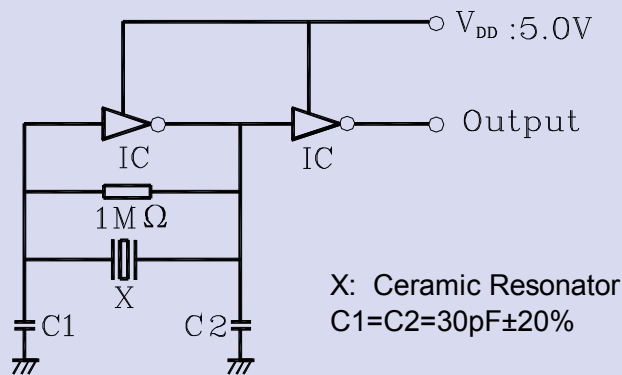

Parts shall be measured under a condition (Temp.: 20±15°C, Humidity: 65±20% R.H.) unless the standard condition (Temp: 25±3°C, Humidity: 65±10% R.H.) is regulated to measure

OPTIONS & PART IDENTIFICATION:



7.4 x 3.4 x 1.8 mm SMD CERAMIC RESONATOR

AWSZT-MGD

Pb in ceramic
(exempt per RoHS 2002/95/EC Annex (7))

**RoHS
Compliant**

AWSZT



7.4 x 3.4 x 1.8 mm

OUTLINE DRAWING:

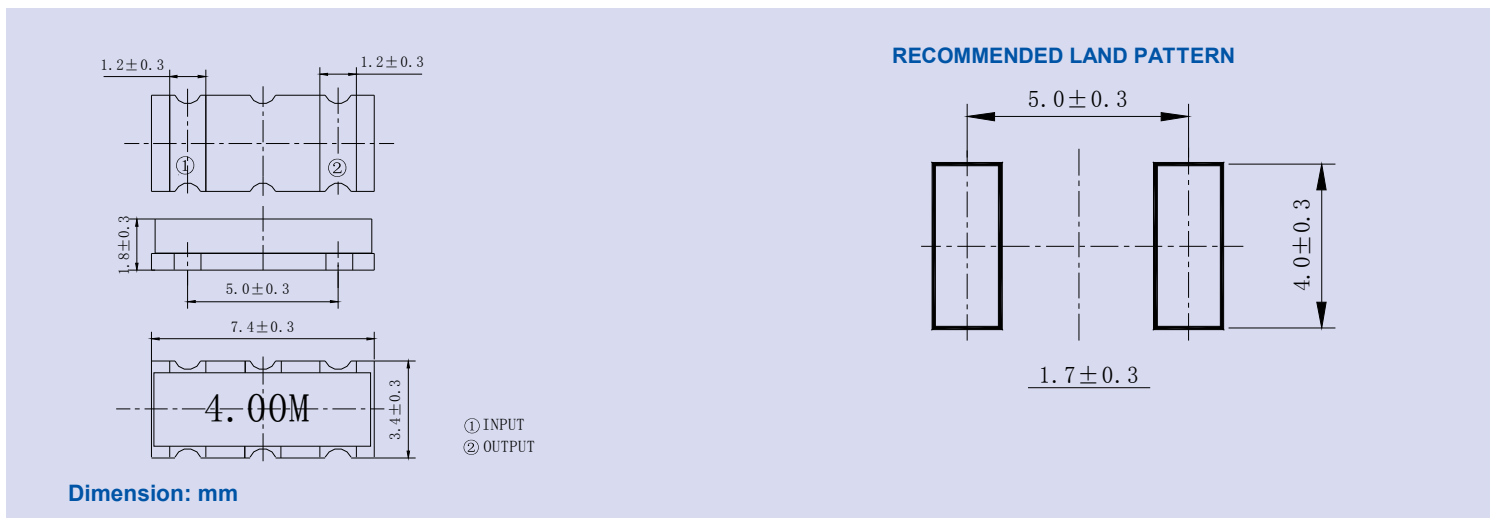

TAPE & REEL: (4,000pcs/reel)

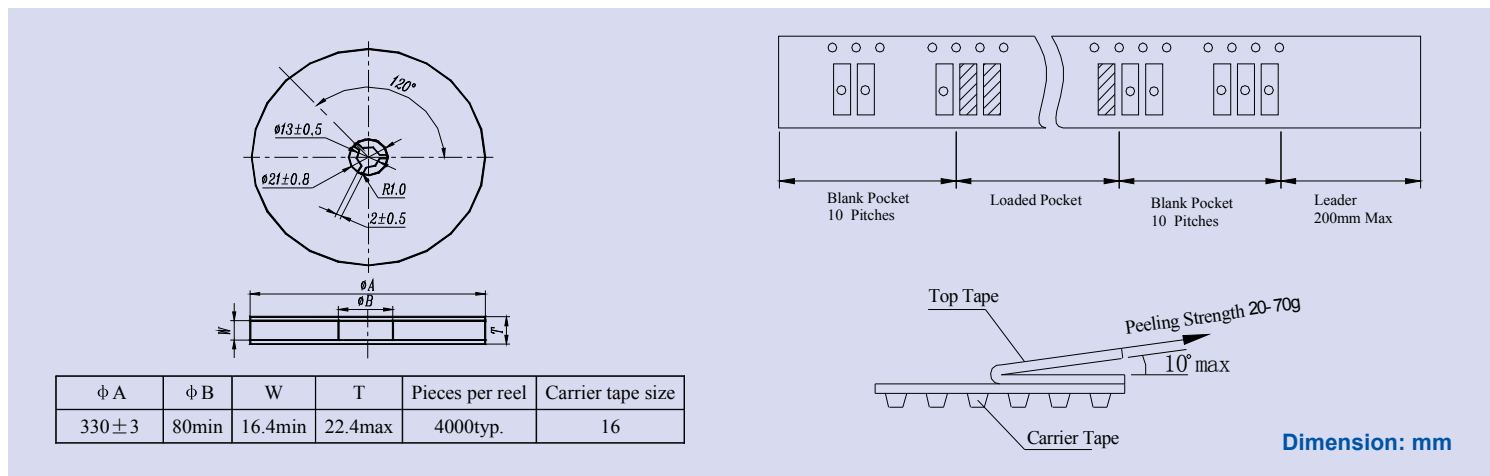

CAUTION

- Do not apply excess mechanical stress to the component body or terminations. Do not attempt to re-form or bend the components as this will cause damage to the component.
- This component is not hermetically sealed. Do not clean or wash the component.
- Reflow Soldering: Do not use strong acidity flux, such as flux with chlorine content of greater than 0.2wt% during Reflow Soldering.
- Do not expose the component to open flame.
- This specification applies to the functionality of the component as a single unit. The customer is advised to insure that the component is thoroughly evaluated in the application circuit.
- Shelf Life: The warranted Shelf Life of this product is Six Months after the Delivery Date under the conditions of sealed, unopened, original packaging.
- Storage Conditions: If the product is to be stored for a period greater than Six Months after the Delivery Date, it is recommended that the customer confirm the solderability and characteristics for the product prior to use.
- This product is not recommended for use in industrial related Automotive, Medical, Safety, Military, or other high-reliability life dependant applications. Contact Abracon Corporation prior to using this product when in doubt.