

Silicon NPN Power Transistors

2SC4467

DESCRIPTION

- With TO-3PN package
- Complement to type 2SA1694

APPLICATIONS

- Audio and general purpose

PINNING

PIN	DESCRIPTION
1	Base
2	Collector;connected to mounting base
3	Emitter

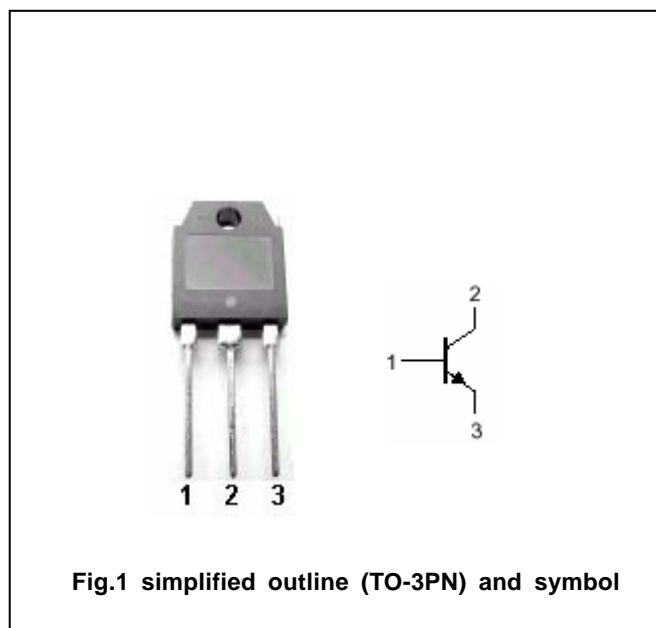

Absolute maximum ratings(Ta=)

SYMBOL	PARAMETER	CONDITIONS	VALUE	UNIT
V_{CBO}	Collector-base voltage	Open emitter	160	V
V_{CEO}	Collector-emitter voltage	Open base	120	V
V_{EBO}	Emitter-base voltage	Open collector	6	V
I_C	Collector current		8	A
I_B	Base current		3	A
P_C	Collector power dissipation	$T_C=25$	80	W
T_j	Junction temperature		150	
T_{stg}	Storage temperature		-55~150	

Silicon NPN Power Transistors

2SC4467

CHARACTERISTICS

T_j=25 unless otherwise specified

SYMBOL	PARAMETER	CONDITIONS	MIN	TYP.	MAX	UNIT
V _{(BR)CEO}	Collector-emitter breakdown voltage	I _C =50mA ; I _B =0	120			V
V _{CEsat}	Collector-emitter saturation voltage	I _C =3A ; I _B =0.3A			1.5	V
I _{CBO}	Collector cut-off current	V _{CB} =160V; I _E =0			10	μ A
I _{EBO}	Emitter cut-off current	V _{EB} =6V; I _C =0			10	μ A
h _{FE}	DC current gain	I _C =3A ; V _{CE} =4V	50		180	
C _{OB}	Output capacitance	I _E =0 ; V _{CB} =10V, f=1MHz		200		pF
f _T	Transition frequency	I _C =0.5A ; V _{CE} =12V		20		MHz

Switching times

t _{on}	Turn-on time	I _C =4A; R _L =10 I _{B1} =- I _{B2} =0.4A V _{CC} =40V		0.13		s
t _s	Storage time			3.50		s
t _f	Fall time			0.32		s

◆ h_{FE} Classifications

O	P	Y
50-100	70-140	90-180

Silicon NPN Power Transistors

2SC4467

PACKAGE OUTLINE

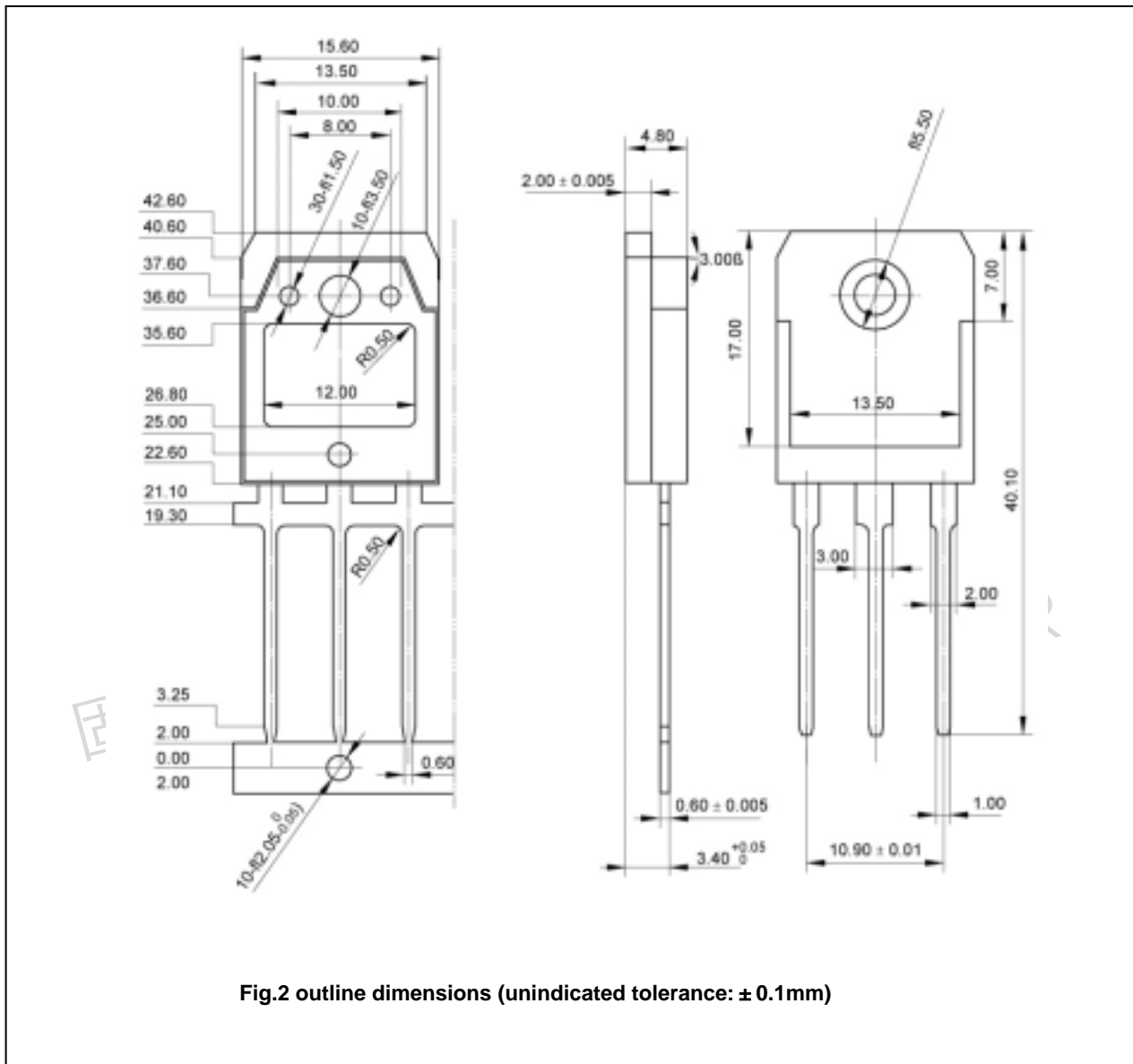

Silicon NPN Power Transistors

2SC4467

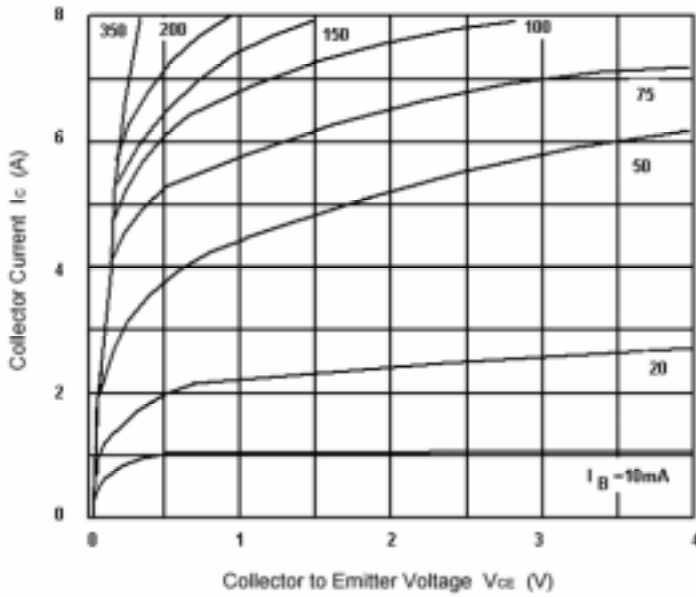

Fig.3 Static Characteristic

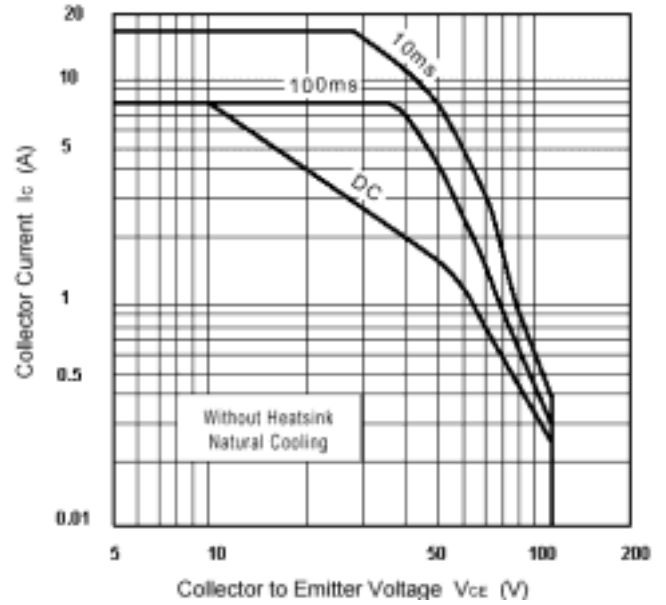

Fig.4 Safe Operating Area

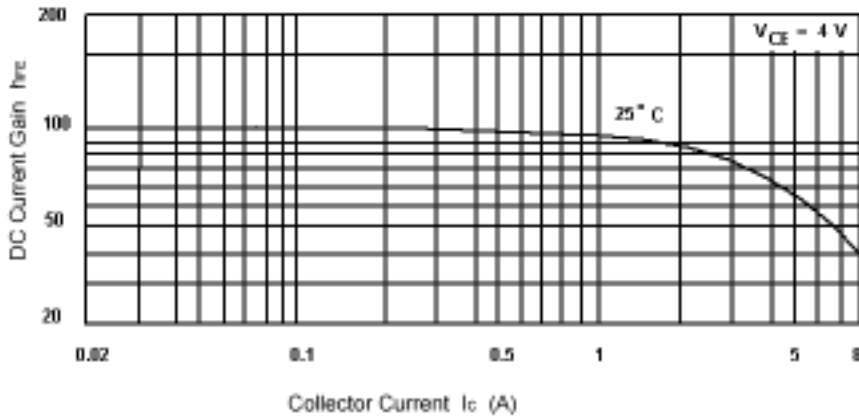

Fig.5 DC current Gain