

isc Silicon PNP Power Transistor

2SB856

**DESCRIPTION**

- Collector Current:  $I_C = -3A$
- Low Collector Saturation Voltage  
:  $V_{CE(sat)} = -1.2V(Max) @ I_C = -2A$
- High Collector Power Dissipation

**APPLICATIONS**

- Designed for low frequency power amplifier applications.

**ABSOLUTE MAXIMUM RATINGS( $T_a=25^{\circ}C$ )**

SYMBOL	PARAMETER	VALUE	UNIT
$V_{CBO}$	Collector-Base Voltage	-50	V
$V_{CEO}$	Collector-Emmitter Voltage	-50	V
$V_{EBO}$	Emmitter-Base Voltage	-4	V
$I_C$	Collector Current-Continuous	-3	A
$P_C$	Total Power Dissipation @ $T_C=25^{\circ}C$	25	W
$T_J$	Junction Temperature	150	$^{\circ}C$
$T_{stg}$	Storage Temperature Range	-45~150	$^{\circ}C$

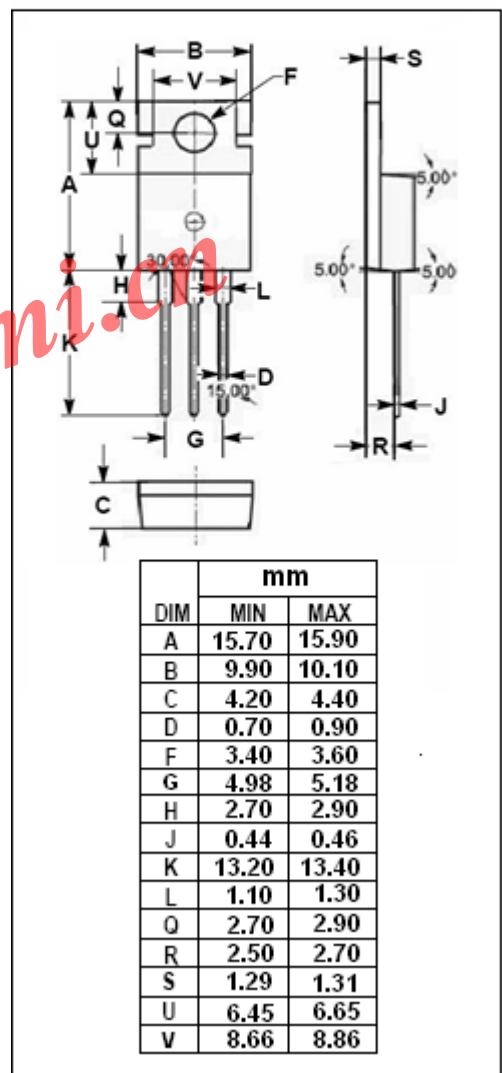
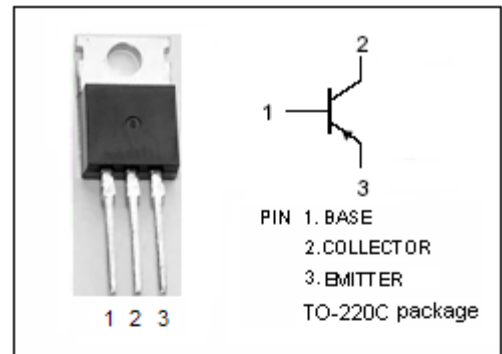

## isc Silicon PNP Power Transistor

2SB856

## ELECTRICAL CHARACTERISTICS

 $T_C=25^\circ\text{C}$  unless otherwise specified

SYMBOL	PARAMETER	CONDITIONS	MIN	TYP.	MAX	UNIT
$V_{(BR)CEO}$	Collector-Emitter Breakdown Voltage	$I_C = -50\text{mA}$ ; $R_{BE} = \infty$	-50			V
$V_{(BR)CBO}$	Collector-Base Breakdown Voltage	$I_C = -5\text{mA}$ ; $I_E = 0$	-50			V
$V_{(BR)EBO}$	Emitter-Base Breakdown Voltage	$I_E = -5\text{mA}$ ; $I_C = 0$	-4			V
$V_{CE(sat)}$	Collector-Emitter Saturation Voltage	$I_C = -2\text{A}$ ; $I_B = -0.2\text{A}$			-1.2	V
$V_{BE(on)}$	Base-Emitter On Voltage	$I_C = -1\text{A}$ ; $V_{CE} = -4\text{V}$			-1.5	V
$I_{CBO}$	Collector Cutoff Current	$V_{CB} = -20\text{V}$ ; $I_E = 0$			-100	$\mu\text{A}$
$h_{FE-1}$	DC Current Gain	$I_C = -1\text{A}$ ; $V_{CE} = -4\text{V}$	35		200	
$h_{FE-2}$	DC Current Gain	$I_C = -0.1\text{A}$ ; $V_{CE} = -4\text{V}$	35			
$f_T$	Current-Gain—Bandwidth Product	$I_C = -0.5\text{A}$ ; $V_{CE} = -4\text{V}$		35		MHz

◆  $h_{FE-1}$  Classifications

A	B	C
35-70	60-120	100-200