

Silicon PNP Power Transistors

2SB762 2SB762A

DESCRIPTION

- With TO-220C package
- Complement to type 2SD857/857A
- Low collector saturation voltage

APPLICATIONS

- For audio frequency power amplifier applications

PINNING

PIN	DESCRIPTION
1	Emitter
2	Collector;connected to mounting base
3	Base

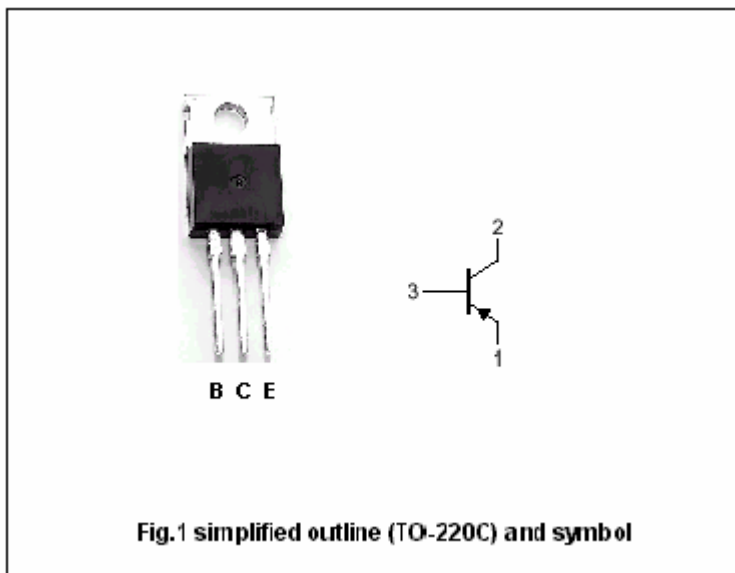

Absolute maximum ratings(Tc=25 )

SYMBOL	PARAMETER	CONDITIONS	VALUE	UNIT
V <sub>CBO</sub>	Collector-base voltage	2SB762	-60	V
		2SB762A	-80	
V <sub>CEO</sub>	Collector-emitter voltage	2SB762	-60	V
		2SB762A	-80	
V <sub>EBO</sub>	Emitter-base voltage	Open collector	-5	V
I <sub>C</sub>	Collector current		-4	A
I <sub>CM</sub>	Collector current-peak		-8	A
P <sub>C</sub>	Collector power dissipation	T <sub>C</sub> =25	40	W
T <sub>j</sub>	Junction temperature		150	
T <sub>stg</sub>	Storage temperature		-55~150	

## Silicon PNP Power Transistors

## 2SB762 2SB762A

## CHARACTERISTICS

T<sub>j</sub>=25 unless otherwise specified

SYMBOL	PARAMETER	CONDITIONS	MIN	TYP.	MAX	UNIT
V <sub>CEO</sub>	Collector-emitter breakdown voltage	2SB762	I <sub>C</sub> =-30mA; I <sub>B</sub> =0	-60		V
		2SB762A		-80		
V <sub>CEsat</sub>	Collector-emitter saturation voltage	I <sub>C</sub> =-4A; I <sub>B</sub> =-0.4 A			-1.5	V
V <sub>BE</sub>	Base-emitter on voltage	I <sub>C</sub> =-3A; V <sub>CE</sub> =-4V			-2.0	V
I <sub>CES</sub>	Collector cut-off current	2SB762	V <sub>CE</sub> =-60V; V <sub>BE</sub> =0		-400	μA
		2SB762A	V <sub>CE</sub> =-80V; V <sub>BE</sub> =0			
I <sub>CEO</sub>	Collector cut-off current	2SB762	V <sub>CE</sub> =-30V; I <sub>B</sub> =0		-700	μA
		2SB762A	V <sub>CE</sub> =-60V; I <sub>B</sub> =0			
I <sub>EBO</sub>	Emitter cut-off current	V <sub>EB</sub> =-5V; I <sub>C</sub> =0			-7	mA
h <sub>FE-1</sub>	DC current gain	I <sub>C</sub> =-1A; V <sub>CE</sub> =-4V	40		250	
h <sub>FE-2</sub>	DC current gain	I <sub>C</sub> =-3A; V <sub>CE</sub> =-4V	15			
Switching times						
t <sub>on</sub>	Turn-on time	I <sub>C</sub> =-4A; I <sub>B1</sub> =-I <sub>B2</sub> =-0.4 A		0.3		μs
t <sub>off</sub>	Turn-off time			1.3		μs

◆ h<sub>FE-1</sub> classifications

R	Q	P
40-90	70-150	120-250

Silicon PNP Power Transistors

2SB762 2SB762A

PACKAGE OUTLINE

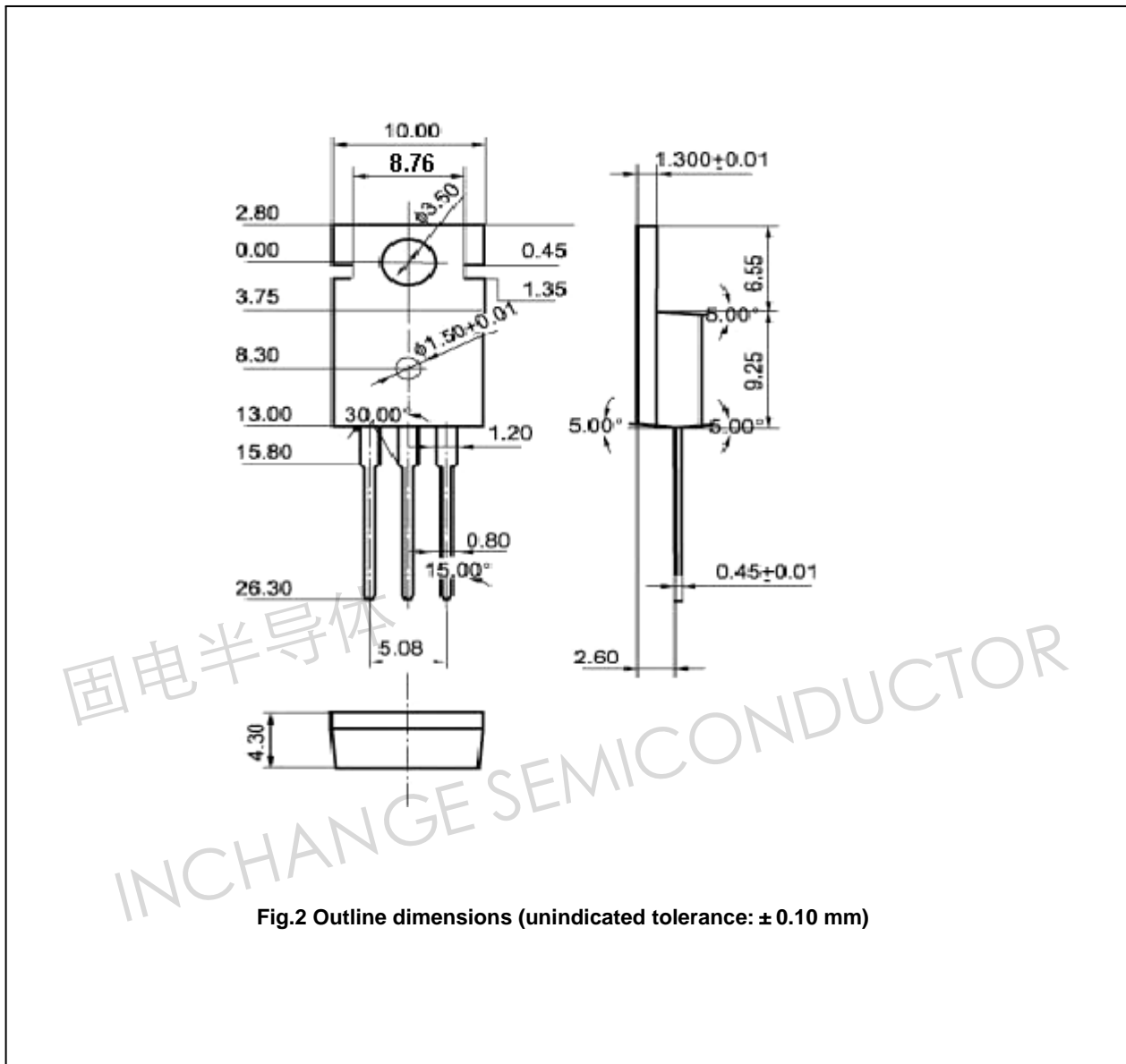

Fig.2 Outline dimensions (unindicated tolerance:  $\pm 0.10$  mm)