

Silicon PNP Power Transistors

2SA489

DESCRIPTION

- With TO-220 package
- Low collector saturation voltage
- Short switching time

APPLICATIONS

- Various inductance lamp drivers for electrical equipment
- Inverters;converters
- Power amplification
- Switching regulator ,driver

PINNING

PIN	DESCRIPTION
1	Emitter
2	Collector;connected to mounting base
3	Base

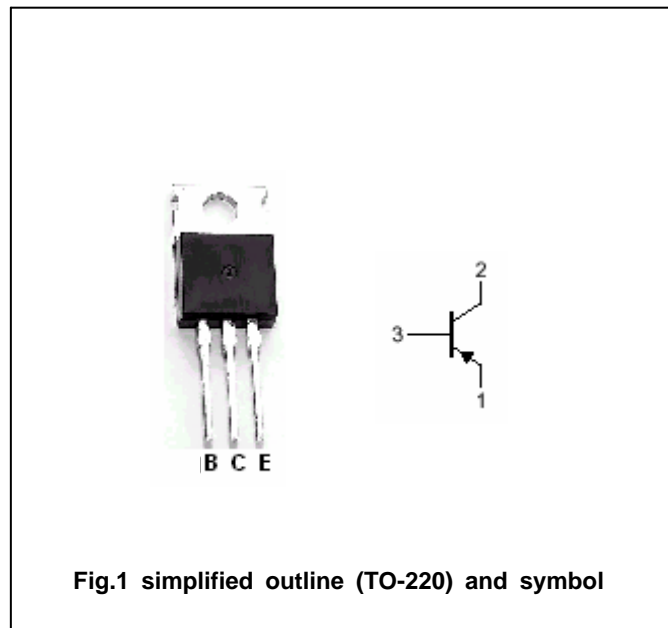
Absolute maximum ratings($T_a=25^\circ\text{C}$)

SYMBOL	PARAMETER	CONDITIONS	VALUE	UNIT
V_{CBO}	Collector-base voltage	Open emitter	-70	V
V_{CEO}	Collector-emitter voltage	Open base	-60	V
V_{EBO}	Emitter-base voltage	Open collector	-5	V
I_C	Collector current		-4	A
P_C	Collector power dissipation	$T_C=25^\circ\text{C}$	30	W
T_j	Junction temperature		150	$^\circ\text{C}$
T_{stg}	Storage temperature		-55~150	$^\circ\text{C}$

Silicon PNP Power Transistors

2SA489

CHARACTERISTICS

T_j=25°C unless otherwise specified

SYMBOL	PARAMETER	CONDITIONS	MIN	TYP.	MAX	UNIT
V _{(BR)CEO}	Collector-emitter breakdown voltage	I _C =-30mA, I _B =0	-60			V
V _{(BR)CBO}	Collector-base breakdown voltage	I _C =-1mA; I _E =0	-70			V
V _{(BR)EBO}	Emitter-base breakdown voltage	I _E =-1mA; I _C =0	-5			V
V _{CEsat}	Collector-emitter saturation voltage	I _C =-3A; I _B =-0.3A			-1.0	V
V _{BEsat}	Base-emitter saturation voltage	I _C =-3A; I _B =-0.3A			-1.5	V
I _{CBO}	Collector cut-off current	V _{CB} =-70V; I _E =0			-10	μ A
I _{EBO}	Emitter cut-off current	V _{EB} =-5V; I _C =0			-10	μ A
h _{FE}	DC current gain	I _C =-0.5A; V _{CE} =-5V	40		240	
f _T	Transition frequency	I _C =-0.5A; V _{CE} =-5V	3			MHz

◆ h_{FE} Classifications

R	O	Y
40-80	70-140	120-240

