

Precision 8-Ch/Dual 4-Ch Low Voltage Analog Multiplexers

DESCRIPTION

The DG3408/3409 uses BiCMOS wafer fabrication technology that allows the DG3408/3409 to operate on single and dual supplies. Single supply voltage ranges from 3 to 12 V while dual supply operation is recommended with ± 3 to ± 6 V.

The DG3408 is an 8-channel single-ended analog multiplexer designed to connect one of eight inputs to a common output as determined by a 3-bit binary address (A_0 , A_1 , A_2). The DG3409 is a dual 4-channel differential analog multiplexer designed to connect one of four differential inputs to a common dual output as determined by its 2-bit binary address (A_0 , A_1). Break-before-make switching action to protect against momentary crosstalk between adjacent channels.

FEATURES

- 2.7 to 12 V Single Supply or ± 3 to ± 6 V Dual Supply Operation
- Low On-Resistance- r_{ON} : 3.9 Ω Typ.
- Fast Switching: t_{ON} - 42 ns, t_{OFF} - 24 ns
- Break-Before-Make Guaranteed
- Low Leakage
- TTL, CMOS, LV Logic (3 V) Compatible
- 2000 V ESD Protection (HBM)
- MICRO FOOT® Package
- Lead (Pb)-free Solder Bumps

RoHS
COMPLIANT

BENEFITS

- High Accuracy
- Single and Dual Power Rail Capacity
- Wide Operating Voltage Range
- Simple Logic Interface

APPLICATIONS

- Data Acquisition Systems
- Battery Operated Equipment
- Portable Test Equipment
- Sample and Hold Circuits
- Communication Systems
- SDSL, DSLAM
- Audio and Video Signal Routing

FUNCTIONAL BLOCK DIAGRAM AND PIN CONFIGURATION

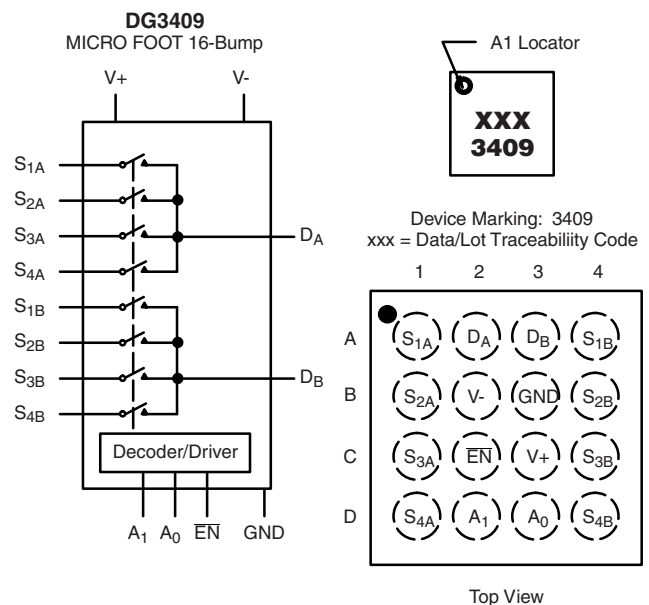
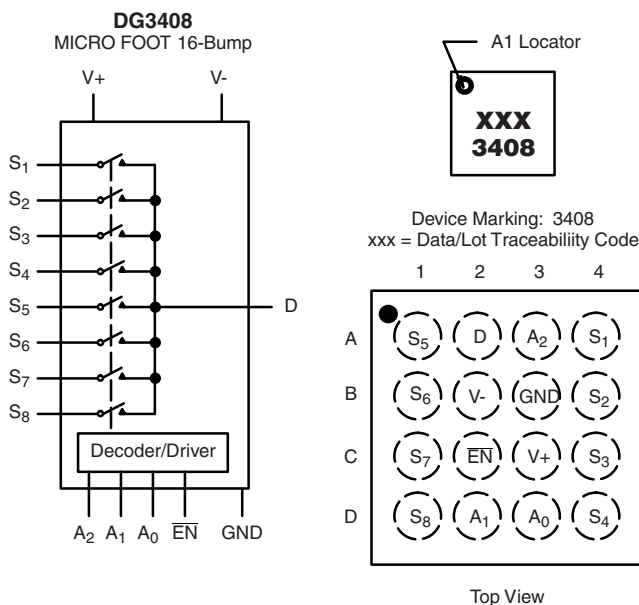



TRUTH TABLES AND ORDERING INFORMATION

TRUTH TABLE - DG3408				
A ₂	A ₁	A ₀	$\overline{\text{EN}}$	On Switch
X	X	X	1	None
0	0	0	0	1
0	0	1	0	2
0	1	0	0	3
0	1	1	0	4
1	0	0	0	5
1	0	1	0	6
1	1	0	0	7
1	1	1	0	8

TRUTH TABLE - DG3409			
A ₁	A ₀	$\overline{\text{EN}}$	On Switch
X	X	1	None
0	0	0	1
0	1	0	2
1	0	0	3
1	1	0	4

X = Do not care

For low and high voltage levels for V_{AX} and V_{EN} consult "Digital Control" Parameters for Specific V+ operation. See Specifications Tables for:

- Single Supply 12 V
- Dual Supply V+ = 5 V, V- = - 5 V
- Single Supply 5 V
- Single Supply 3 V

ORDERING INFORMATION - DG3408		
Temperature Range	Package	Part Number
- 40 to 85 °C	MICRO FOOT: 16-Bump (4 x 4, 0.5 mm Pitch, 238 μm Bump Height)	DG3408DB-T2-E1 (Lead (Pb)-free)

ORDERING INFORMATION - DG3409		
Temperature Range	Package	Part Number
- 40 to 85 °C	MICRO FOOT: 16-Bump (4 x 4, 0.5 mm Pitch, 238 μm Bump Height)	DG3409DB-T2-E1 (Lead (Pb)-free)

ABSOLUTE MAXIMUM RATINGS T _A = 25 °C, unless otherwise noted		
Parameter	Limit	Unit
Voltage Referenced V+ to V-	14	V
GND	7	
Digital Inputs ^a , V _S , V _D	(V-) - 0.3 V to (V) + 0.3 V	
Current (Any Terminal Except S or D)	30	mA
Continuous Current, S or D)	100	
Peak Current, S or D (Pulsed at 1 ms, 10 % Duty Cycle Max)	200	
Package Solder Reflow Conditions ^b	IR/Convection	°C
Storage Temperature	- 65 to 150	
Power Dissipation (Package) ^c , (T _A = 70 °C)	16-Bump (4 x 4 mm) MICRO FOOT ^d	mW

Notes:

- a. Signals on S_X, D_X or I_{NX} exceeding V+ or V- will be clamped by internal diodes. Limit forward diode current to maximum current ratings.
- b. Refer to IPC/JEDEC (J-STD-020B).
- c. All bumps soldered or welded to PC board.
- d. Derate 9.0 mW/°C above 70 °C.



SPECIFICATIONS (SINGLE SUPPLY 12 V)							
Parameter	Symbol	Test Conditions Unless Otherwise Specified $V_+ = 12\text{ V}, \pm 10\%, V_- = 0\text{ V}$ $V_A, V_{\overline{EN}} = 0.8\text{ V or } 2.4\text{ V}^f$	Temp ^b	Limits - 40 to 85 °C			Unit
				Min ^c	Typ ^d	Max ^c	
Analog Switch							
Analog Signal Range ^e	V_{ANALOG}		Full	0		12	V
On-Resistance	r_{ON}	$V_+ = 10.8\text{ V}, V_D = 2\text{ V or } 9\text{ V}, I_S = 50\text{ mA}$ Sequence Each Switch On	Room Full		4	7 7.5	Ω
r_{ON} Match Between Channels ^g	Δr_{ON}	$V_+ = 10.8\text{ V}, V_D = 2\text{ V or } 9\text{ V}, I_S = 50\text{ mA}$	Room			3.6	
On-Resistance Flatness ⁱ	r_{ON} Flatness		Room				
Switch Off Leakage Current	$I_{\text{S(off)}}$	$V_{\overline{EN}} = 2.4\text{ V}, V_D = 11\text{ V or } 1\text{ V}, V_S = 1\text{ V or } 11\text{ V}$	Room Full	- 2 - 20		2 20	nA
	$I_{\text{D(off)}}$		Room Full	- 2 - 20		2 20	
Channel On Leakage Current	$I_{\text{D(on)}}$	$V_{\overline{EN}} = 0\text{ V}, V_S = V_D = 1\text{ V or } 11\text{ V}$	Room Full	- 2 - 20		2 20	
Digital Control							
Logic High Input Voltage	V_{INH}		Full	2.4			V
Logic Low Input Voltage	V_{INL}		Full			0.8	
Input Current	I_{IN}	$V_{\text{AX}} = V_{\overline{EN}} = 2.4\text{ V or } 0.8\text{ V}$	Full	- 1		1	μA
Dynamic Characteristics							
Transition Time	t_{TRANS}	$V_{\text{S1}} = 8\text{ V}, V_{\text{S8}} = 0\text{ V}, (\text{DG3408})$ $V_{\text{S1b}} = 8\text{ V}, V_{\text{S4b}} = 0\text{ V}, (\text{DG3409})$ See Figure 2	Room Full			42 71 75	ns
Break-Before-Make Time	t_{BBM}	$V_{\text{S(all)}} = V_{\text{DA}} = 5\text{ V}$ See Figure 4	Room Full	2		24	
Enable Turn-On Time	$t_{\text{ON}(\overline{\text{EN}})}$	$V_{\text{AX}} = 0\text{ V}, V_{\text{S1}} = 5\text{ V} (\text{DG3408})$ $V_{\text{AX}} = 0\text{ V}, V_{\text{S1b}} = 5\text{ V} (\text{DG3409})$ See Figure 3	Room Full			42 70 75	
Enable Turn-Off Time	$t_{\text{OFF}(\overline{\text{EN}})}$		Room Full			24 44 46	
Charge Injection ^e	Q	$C_L = 1\text{ nF}, V_{\text{GEN}} = 0\text{ V}, R_{\text{GEN}} = 0\text{ Ω}$	Room			29	pC
Off Isolation ^{e, h}	OIRR	$f = 100\text{ kHz}, R_L = 1\text{ kΩ}$	Room			- 80	dB
Crosstalk ^e	X_{TALK}		Room			- 85	
Source Off Capacitance ^e	$C_{\text{S(off)}}$	$f = 1\text{ MHz}, V_S = 0\text{ V}, V_{\overline{EN}} = 2.4\text{ V}$	DG3408 Room			21	pF
			DG3409 Room			23	
Drain Off Capacitance ^e	$C_{\text{D(off)}}$	$f = 1\text{ MHz}, V_D = 0\text{ V}, V_{\overline{EN}} = 2.4\text{ V}$	DG3408 Room			211	
			DG3409 Room			112	
Drain On Capacitance ^e	$C_{\text{D(on)}}$	$f = 1\text{ MHz}, V_D = 0\text{ V}, V_{\overline{EN}} = 0\text{ V}$	DG3408 Room			238	
			DG3409 Room			137	
Power Supplies							
Power Supply Current	I+	$V_{\overline{EN}} = V_A = 0\text{ V or } V_+$	Room			1.0	μA



SPECIFICATIONS (DUAL SUPPLY V+ = 5 V, V- = - 5 V)							
Parameter	Symbol	Test Conditions Unless Otherwise Specified V+ = 5 V, V- = - 5 V, ± 10 % VA, VEN = 0.8 V or 2.0 V ^f	Temp ^b	Limits - 40 to 85 °C			Unit
				Min ^c	Typ ^d	Max ^c	
Analog Switch							
Analog Signal Range ^e	V _{ANALOG}		Full	- 5		5	V
On-Resistance	r _{ON}	V+ = 4.5 V, V- = - 4.5 V, V _D = ± 3.5 V, I _S = 50 mA, Sequence Each Switch On	Room Full		5	8 8.5	Ω
r _{ON} Match Between Channels ^g	Δr _{ON}		Room			3.6	
On-Resistance Flatness ⁱ	r _{ON} Flatness	V+ = 4.5 V, V- = - 4.5 V, V _D = ± 3.5 V, I _S = 50 mA	Room			8.2	
Switch Off Leakage Current ^a	I _{S(off)}	V+ = 5.5 V, V- = - 5.5 V VEN = 2.4 V, V _D = ± 4.5 V, V _S = ± 4.5 V	Room Full	- 2 - 20		2 20	nA
	I _{D(off)}		Room Full	- 2 - 20		2 20	
Channel On Leakage Current ^a	I _{D(on)}	V+ = 5.5 V, V- = - 5.5 V VEN = 0 V, V _D = ± 4.5 V, V _S = ± 4.5 V	Room Full	- 2 - 20		2 20	
Digital Control							
Logic High Input Voltage	V _{INH}		Full	2.0			V
Logic Low Input Voltage	V _{INL}		Full			0.8	
Input Current ^a	I _{IN}	V _{AX} = V _{EN} = 2.0 V or 0.8 V	Full	- 1		1	μA
Dynamic Characteristics							
Transition Time ^e	t _{TRANS}	V _{S1} = 3.5 V, V _{S8} = - 3.5 V, (DG3408) V _{S1b} = 3.5 V, V _{S4b} = - 3.5 V, (DG3409) See Figure 2	Room Full		68	89 94	ns
Break-Before-Make Time ^e	t _{BBM}	V _{S(all)} = V _{DA} = 3.5 V See Figure 4	Room Full	1	16		
Enable Turn-On Time ^e	t _{ON(EN)}	V _{AX} = 0 V, V _{S1} = 3.5 V (DG3408) V _{AX} = 0 V, V _{S1b} = 3.5 V (DG3409) See Figure 3	Room Full		68	88 94	
Enable Turn-Off Time ^e	t _{OFF(EN)}		Room Full		58	78 81	
Source Off Capacitance ^e	C _{S(off)}	f = 1 MHz, V _S = 0 V, VEN = 2.0 V	DG3408	Room		23	pF
			DG3409	Room		23	
Drain Off Capacitance ^e	C _{D(off)}	f = 1 MHz, V _D = 0 V, VEN = 2.0 V	DG3408	Room		223	
			DG3409	Room		113	
Drain On Capacitance ^e	C _{D(on)}	f = 1 MHz, V _D = 0 V, VEN = 0 V	DG3408	Room		246	
			DG3409	Room		137	
Power Supplies							
Power Supply Current	I+	VEN = VA = 0 V or V+	Room			1.0	μA
	I-		Room	- 1.0			



SPECIFICATIONS (SINGLE SUPPLY 5 V)							
Parameter	Symbol	Test Conditions Unless Otherwise Specified $V_+ = 5\text{ V}, \pm 10\%, V_- = 0\text{ V}$ $V_A, V_{\overline{EN}} = 0.8\text{ V or }2.0\text{ V}^f$	Temp ^b	Limits - 40 to 85 °C			Unit
				Min ^c	Typ ^d	Max ^c	
Analog Switch							
Analog Signal Range ^e	V_{ANALOG}		Full	0		5	V
On-Resistance	r_{ON}	$V_+ = 4.5\text{ V}, V_D \text{ or } V_S = 1\text{ V or }3.5\text{ V}, I_S = 50\text{ mA}$	Room Full		7	10.5 11	Ω
r_{ON} Match Between Channels ^g	Δr_{ON}	$V_+ = 4.5\text{ V}, V_D = 1\text{ V or }3.5\text{ V}, I_S = 50\text{ mA}$	Room			3.6	
On-Resistance Flatness ⁱ	r_{ON} Flatness		Room				
Switch Off Leakage Current ^a	$I_{\text{S(off)}}$	$V_+ = 5.5\text{ V}$ $V_S = 1\text{ V or }4\text{ V}, V_D = 4\text{ V or }1\text{ V}$	Room Full	- 2 - 20		2 20	nA
	$I_{\text{D(off)}}$		Room Full	- 2 - 20		2 20	
Channel On Leakage Current ^a	$I_{\text{D(on)}}$	$V_+ = 5.5\text{ V}$ $V_D = V_S = 1\text{ V or }4\text{ V}, \text{ Sequence Each Switch On}$	Room Full	- 2 - 20		2 20	
Digital Control							
Logic High Input Voltage	V_{INH}	$V_+ = 5\text{ V}$	Full	2.0			V
Logic Low Input Voltage	V_{INL}		Full			0.8	
Input Current ^a	I_{IN}	$V_{\text{AX}} = V_{\overline{\text{EN}}} = 2.0\text{ V or }0.8\text{ V}$	Full	- 1		1	μA
Dynamic Characteristics							
Transition Time ^e	t_{TRANS}	$V_{\text{S1}} = 3.5\text{ V}, V_{\text{S8}} = 0\text{ V}, \text{ (DG3408)}$ $V_{\text{S1b}} = 3.5\text{ V}, V_{\text{S4b}} = 0\text{ V}, \text{ (DG3409)}$ See Figure 2	Room Full		73	94 104	ns
Break-Before-Make Time ^e	t_{OPEN}	$V_{\text{S(all)}} = V_{\text{DA}} = 3.5\text{ V}$ See Figure 4	Room Full	2	29		
Enable Turn-On Time ^e	$t_{\text{ON}(\overline{\text{EN}})}$	$V_{\text{AX}} = 0\text{ V}, V_{\text{S1}} = 3.5\text{ V} \text{ (DG3408)}$ $V_{\text{AX}} = 0\text{ V}, V_{\text{S1b}} = 3.5\text{ V} \text{ (DG3409)}$ See Figure 3	Room Full		74	94 104	
Enable Turn-Off Time ^e	$t_{\text{OFF}(\overline{\text{EN}})}$		Room Full		38	57 61	
Charge Injection ^e	Q	$C_L = 1\text{ nF}, R_{\text{GEN}} = 0\ \Omega, V_{\text{GEN}} = 0\text{ V}$	Room		20		
Off Isolation ^{e, h}	OIRR	$R_L = 1\text{ k}\Omega, f = 100\text{ kHz}$	Room		- 81		dB
Crosstalk ^e	X_{TALK}		Room		- 85		
Source Off Capacitance ^e	$C_{\text{S(off)}}$	$f = 1\text{ MHz}, V_S = 0\text{ V}, V_{\overline{\text{EN}}} = 0\text{ V}$	DG3408	Room		22	pF
			DG3409	Room		24	
Drain Off Capacitance ^e	$C_{\text{D(off)}}$	$f = 1\text{ MHz}, V_D = 0\text{ V}, V_{\overline{\text{EN}}} = 2.0\text{ V}$	DG3408	Room		223	
			DG3409	Room		113	
Drain On Capacitance ^e	$C_{\text{D(on)}}$	$f = 1\text{ MHz}, V_D = 0\text{ V}, V_{\overline{\text{EN}}} = 0\text{ V}$	DG3408	Room		244	
			DG3409	Room		143	
Power Supplies							
Power Supply Current	I+	$V_{\overline{\text{EN}}} = V_A = 0\text{ V or }V_+$	Room			1.0	μA



SPECIFICATIONS (SINGLE SUPPLY 3 V)							
Parameter	Symbol	Test Conditions Unless Otherwise Specified $V_+ = 3\text{ V}, \pm 10\%$, $V_- = 0\text{ V}$ $V_{\overline{\text{EN}}} = 0.4\text{ V}$ or 1.8 V^f	Temp ^b	Limits - 40 to 85 °C			Unit
				Min ^c	Typ ^d	Max ^c	
Analog Switch							
Analog Signal Range ^e	V_{ANALOG}		Full	0		3	V
On-Resistance	r_{ON}	$V_+ = 2.7\text{ V}, V_{\text{D}} = 0.5\text{ or }2.2\text{ V}, I_{\text{S}} = 5\text{ mA}$	Room Full		12	25.5 26.5	Ω
r_{ON} Match Between Channels ^g	Δr_{ON}	$V_+ = \pm 2.7\text{ V}, V_{\text{D}} = 0.5\text{ V or }2.2\text{ V}, I_{\text{S}} = 5\text{ mA}$	Room			3.6	
On-Resistance Flatness ⁱ	r_{ON} Flatness		Room			13	
Switch Off Leakage Current ^a	$I_{\text{S(off)}}$	$V_+ = 3.3\text{ V}$ $V_{\text{S}} = 2\text{ or }1\text{ V}, V_{\text{D}} = 1\text{ or }2\text{ V}$	Room Full	- 2 - 20		2 20	nA
	$I_{\text{D(off)}}$		Room Full	- 2 - 20		2 20	
Channel On Leakage Current ^a	$I_{\text{D(on)}}$	$V_+ = 3.3\text{ V}$ $V_{\text{D}} = V_{\text{S}} = 1\text{ or }2\text{ V}, \text{Sequence Each Switch On}$	Room Full	- 2 - 20		2 20	
Digital Control							
Logic High Input Voltage	V_{INH}		Full	1.8			V
Logic Low Input Voltage	V_{INL}		Full			0.4	
Input Current ^a	I_{IN}	$V_{\text{AX}} = V_{\overline{\text{EN}}} = 1.8\text{ V or }0.4\text{ V}$	Full	- 1		1	μA
Dynamic Characteristics							
Transition Time	t_{TRANS}	$V_{\text{S1}} = 1.5\text{ V}, V_{\text{S8}} = 0\text{ V}, (\text{DG3408})$ $V_{\text{S1b}} = 1.5\text{ V}, V_{\text{S4b}} = 0\text{ V}, (\text{DG3409})$ See Figure 2	Room Full		140	165 182	ns
Break-Before-Make Time	t_{BBM}	$V_{\text{S(all)}} = V_{\text{DA}} = 1.5\text{ V}$ See Figure 4	Room Full	2	63		
Enable Turn-On Time	$t_{\text{ON}(\overline{\text{EN}})}$	$V_{\text{AX}} = 0\text{ V}, V_{\text{S1}} = 1.5\text{ V} (\text{DG3408})$ $V_{\text{AX}} = 0\text{ V}, V_{\text{S1b}} = 1.5\text{ V} (\text{DG3409})$ See Figure 3	Room Full		140	162 178	
Enable Turn-Off Time	$t_{\text{OFF}(\overline{\text{EN}})}$		Room Full		76	97 104	
Charge Injection ^e	Q	$C_{\text{L}} = 1\text{ nF}, R_{\text{GEN}} = 0, V_{\text{GEN}} = 0\text{ V}$	Room		7		μC
Off Isolation ^{e, h}	OIRR	$f = 100\text{ kHz}, R_{\text{L}} = 1\text{ k}\Omega$	Room		- 81		dB
Crosstalk ^e	X_{TALK}		Room		- 85		
Source Off Capacitance ^e	$C_{\text{S(off)}}$	$f = 1\text{ MHz}, V_{\text{S}} = 0\text{ V}, V_{\overline{\text{EN}}} = 1.8\text{ V}$	DG3408	Room		23	pF
			DG3409	Room		25	
Drain Off Capacitance ^e	$C_{\text{D(off)}}$	$f = 1\text{ MHz}, V_{\text{D}} = 0\text{ V}, V_{\overline{\text{EN}}} = 1.8\text{ V}$	DG3408	Room		230	
			DG3409	Room		120	
Drain On Capacitance ^e	$C_{\text{D(on)}}$	$f = 1\text{ MHz}, V_{\text{D}} = 0\text{ V}, V_{\overline{\text{EN}}} = 0\text{ V}$	DG3408	Room		256	
			DG3409	Room		147	
Power Supplies							
Power Supply Current	I+	$V_{\overline{\text{EN}}} = V_{\text{A}} = 0\text{ V or }V_+$	Room			1.0	μA

Notes:

- a. Leakage parameters are guaranteed by worst case test condition and not subject to production test.
- b. Room = 25 °C, Full = as determined by the operating temperature suffix.
- c. The algebraic convention whereby the most negative value is a minimum and the most positive a maximum, is used in this data sheet.
- d. Typical values are for DESIGN AID ONLY, not guaranteed nor subject to production testing.
- e. Guaranteed by design, not subject to production test.
- f. V_{IN} = input voltage to perform proper function.
- g. $\Delta r_{\text{DON}} = r_{\text{DON Max}} - r_{\text{DON Min}}$.
- h. Worst case isolation occurs on Channel 4 due to proximity to the drain pin.
- i. r_{DON} flatness is measured as the difference between the minimum and maximum measured values across a defined Analog signal.

Stresses beyond those listed under "Absolute Maximum Ratings" may cause permanent damage to the device. These are stress ratings only, and functional operation of the device at these or any other conditions beyond those indicated in the operational sections of the specifications is not implied. Exposure to absolute maximum rating conditions for extended periods may affect device reliability.

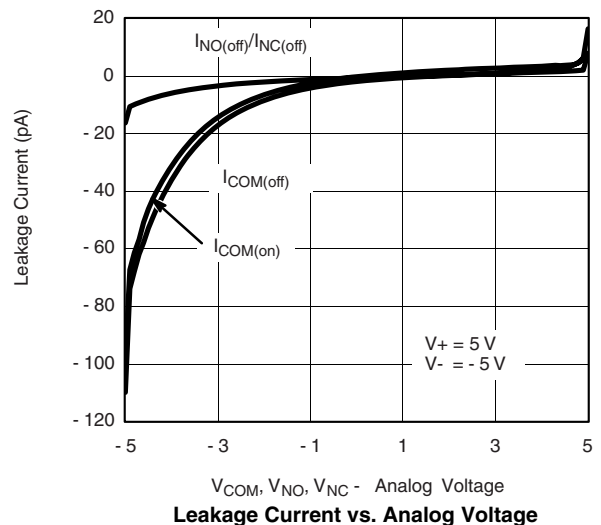
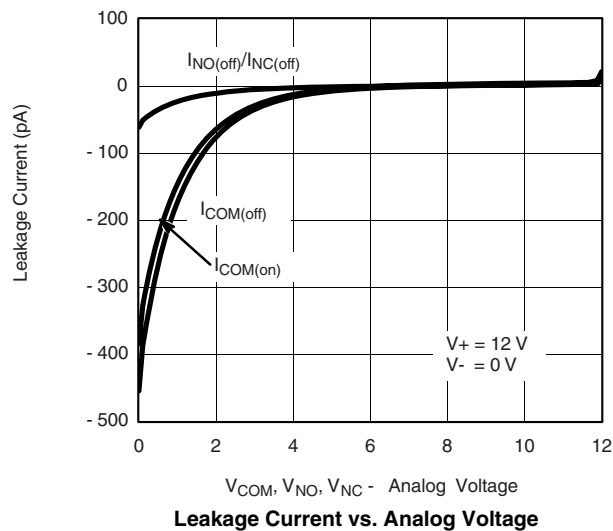
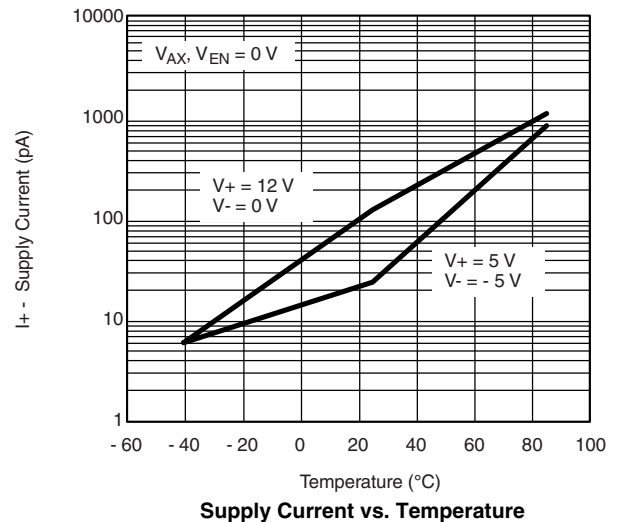
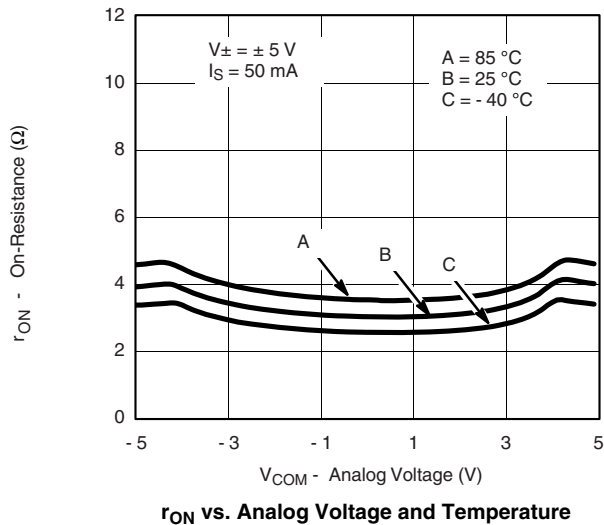
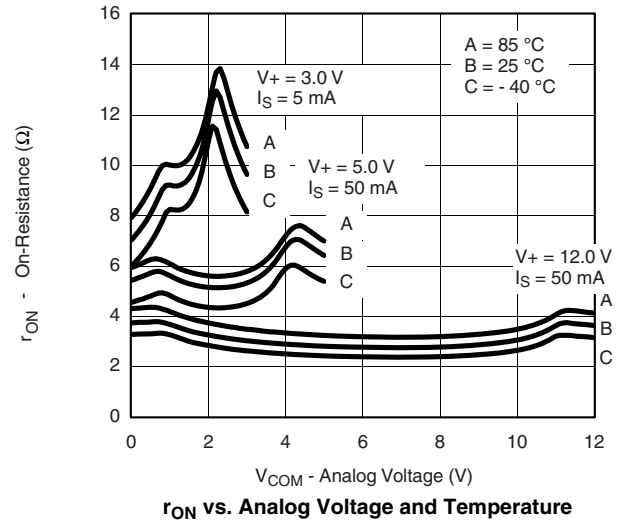
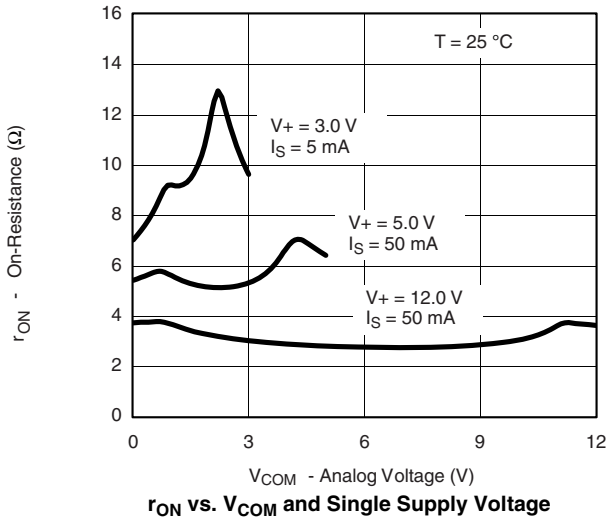
TYPICAL CHARACTERISTICS 25 °C, unless otherwise noted

TYPICAL CHARACTERISTICS 25 °C, unless otherwise noted

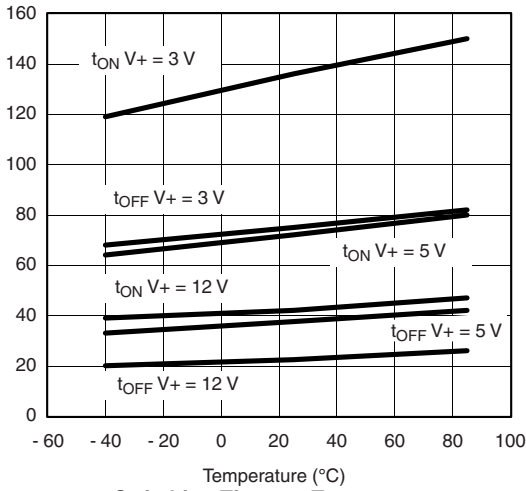

Switching Time vs. Temperature and Single Supply Voltage

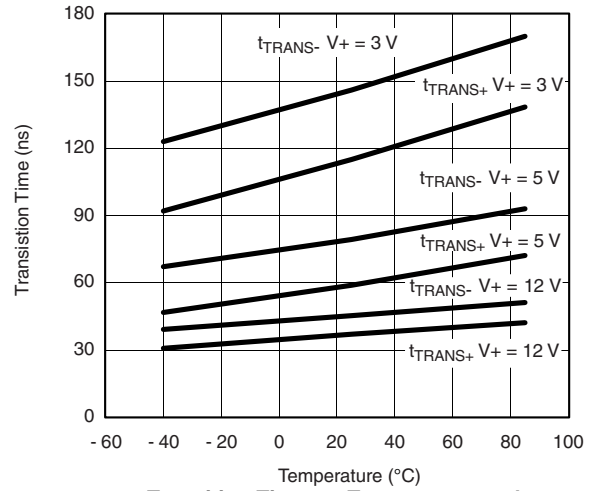

Transition Time vs. Temperature and Single Supply Voltage

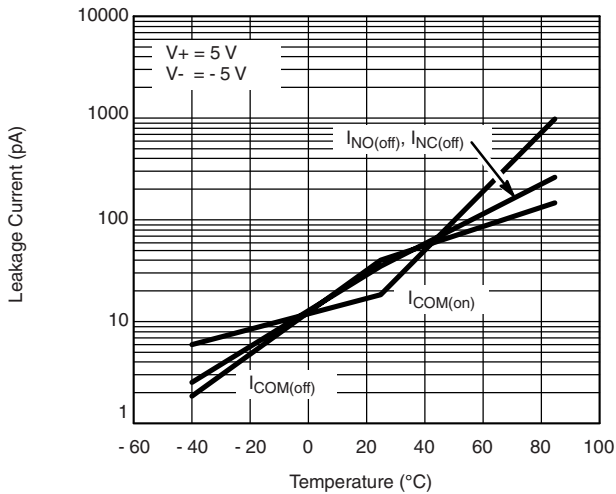

Leakage Current vs. Temperature

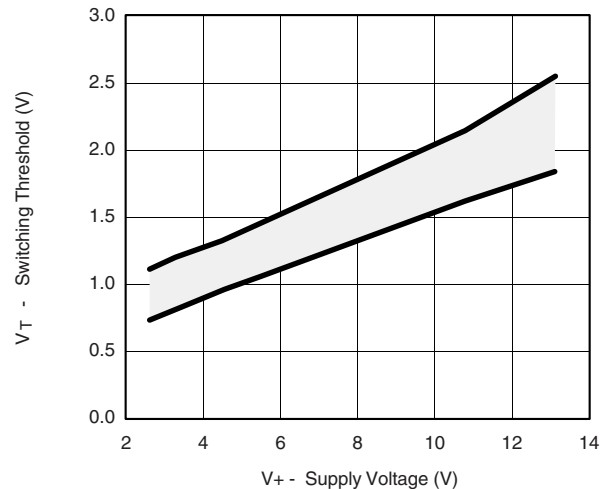

Switching Threshold vs. Supply Voltage

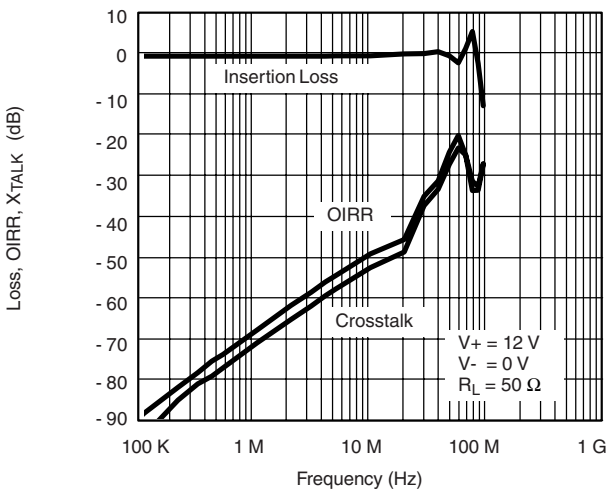

Insertion Loss, Off Isolation and Crosstalk vs. Frequency (DG3408)

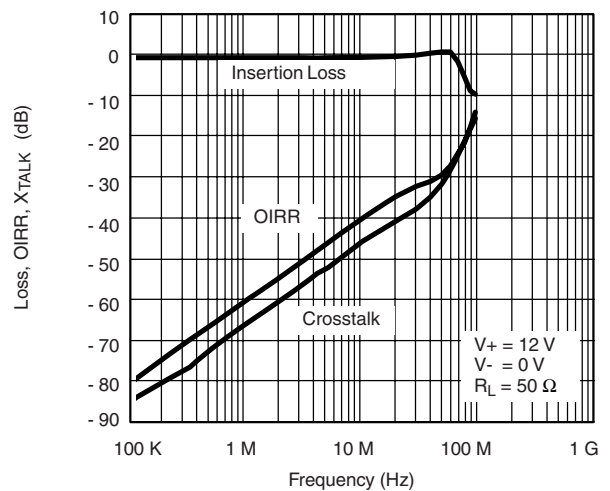

Insertion Loss, Off Isolation and Crosstalk vs. Frequency (DG3409)

TYPICAL CHARACTERISTICS 25 °C, unless otherwise noted

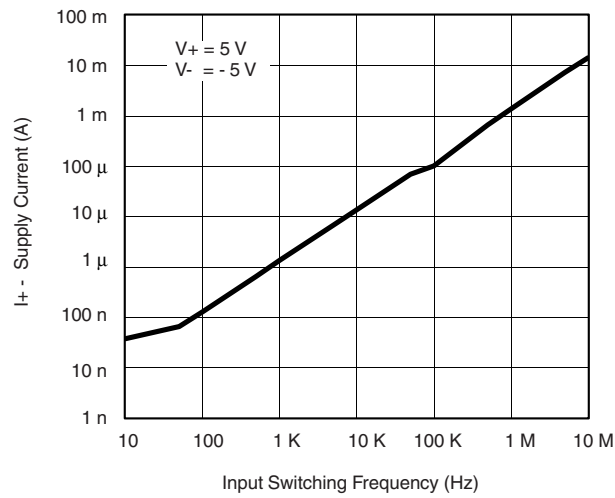

Supply Current vs. Input Switching Frequency

SCHEMATIC DIAGRAM (TYPICAL CHANNEL)

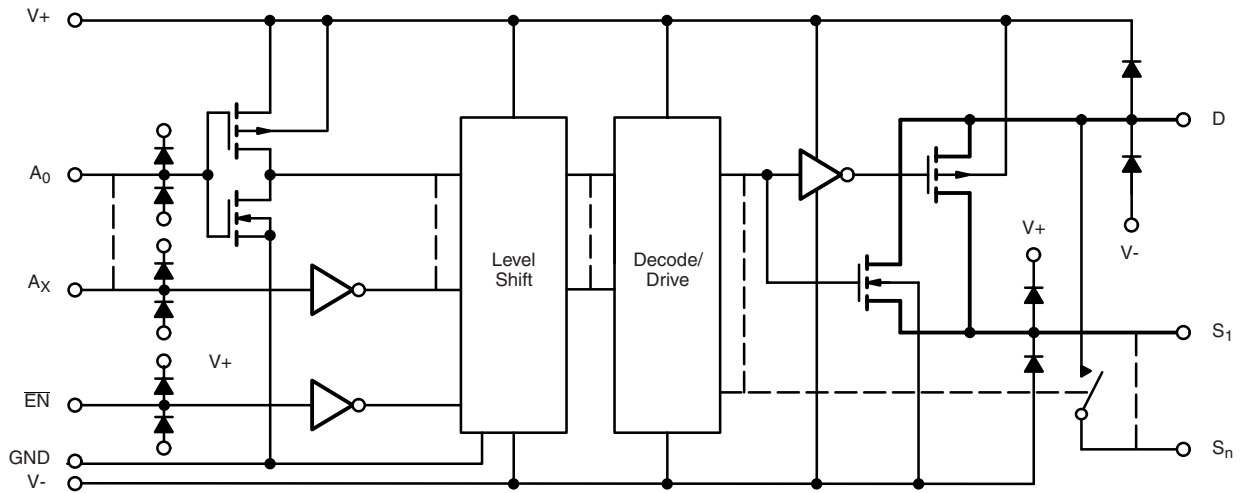
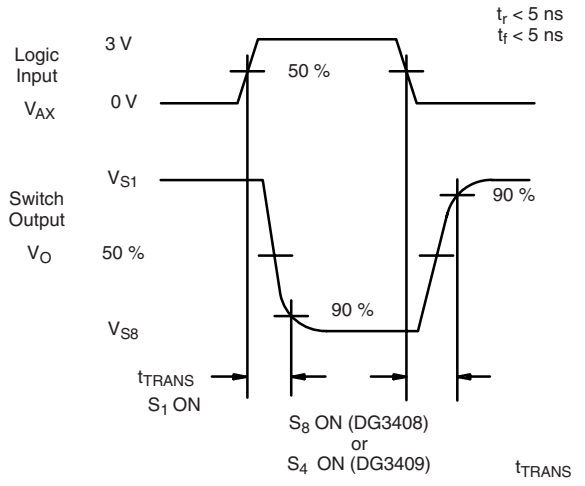
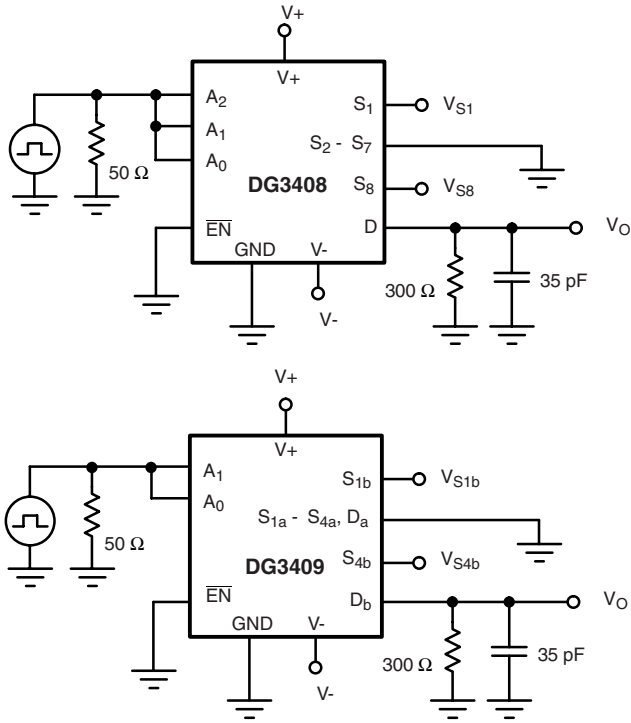

Figure 1.

TEST CIRCUITS



Return to Specifications:
 Single Supply 12 V
 Dual Supply $V_+ = 5\text{ V}$, $V_- = -5\text{ V}$
 Single Supply 5 V
 Single Supply 3 V

Figure 2. Transition Time

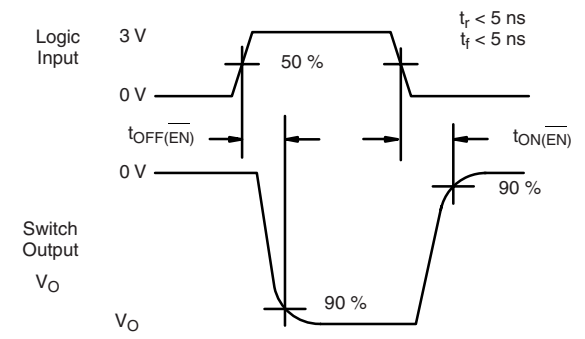
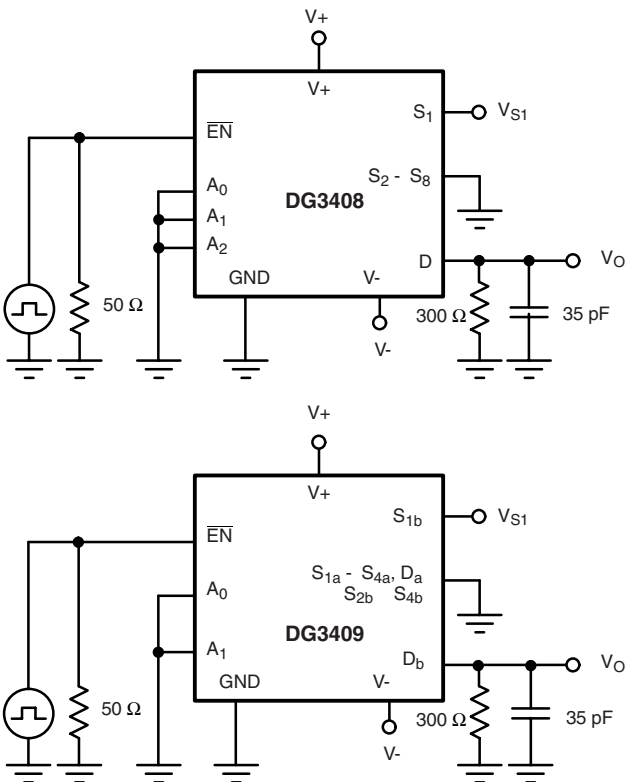

Return to Specifications:
 Single Supply 12 V
 Dual Supply $V_+ = 5\text{ V}$, $V_- = -5\text{ V}$
 Single Supply 5 V
 Single Supply 3 V

Figure 3. Enable Switching Time

TEST CIRCUITS

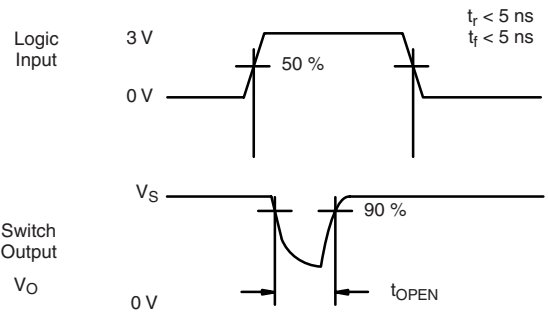
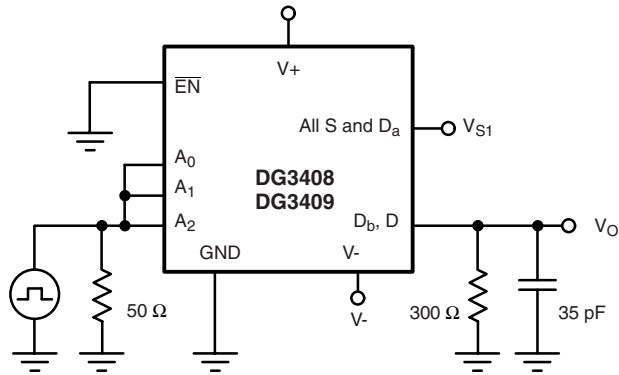

Return to Specifications:
 Single Supply 12 V
 Dual Supply V+ = 5 V, V- = - 5 V
 Single Supply 5 V
 Single Supply 3 V

Figure 4. Break-Before-Make Interval

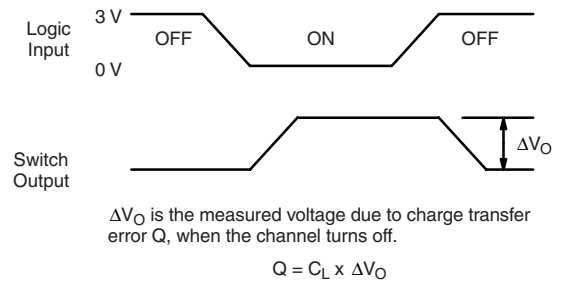
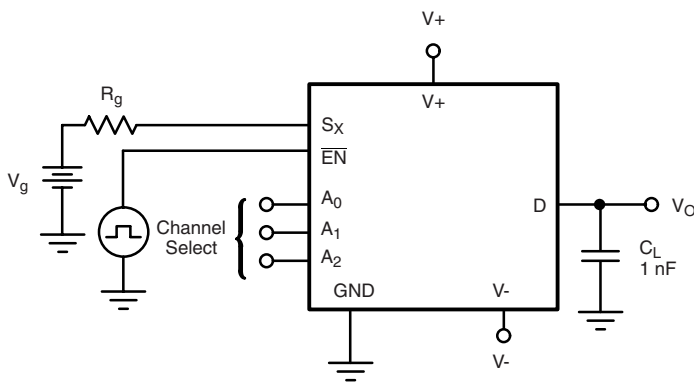

Figure 5. Charge Injection

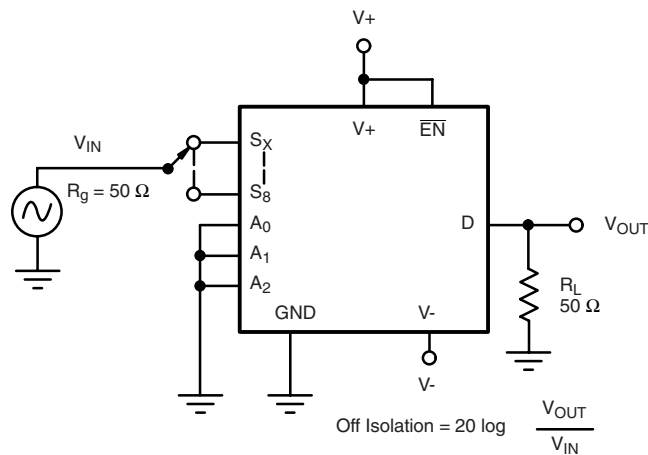

Figure 6. Off Isolation

TEST CIRCUITS

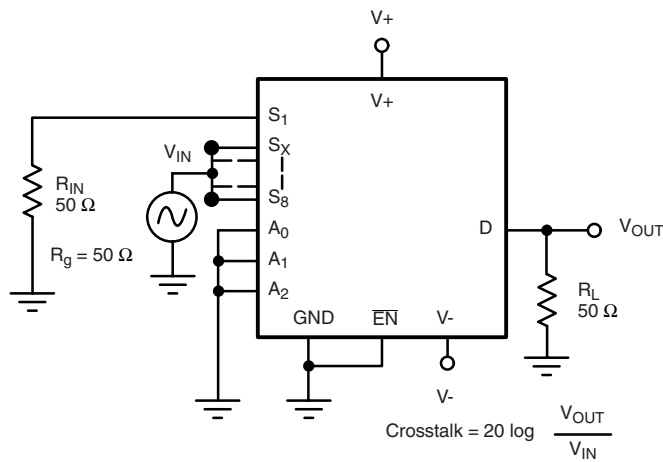

Figure 7. Crosstalk

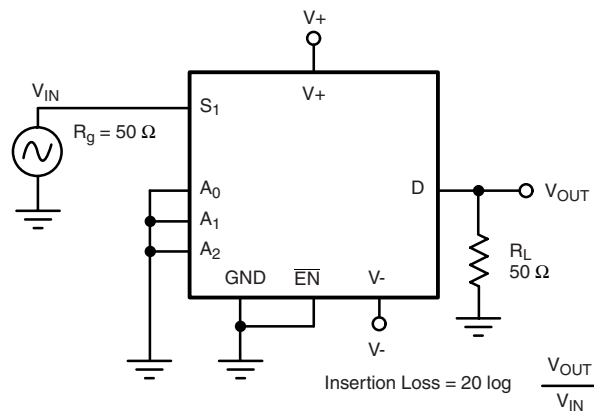

Figure 8. Insertion Loss

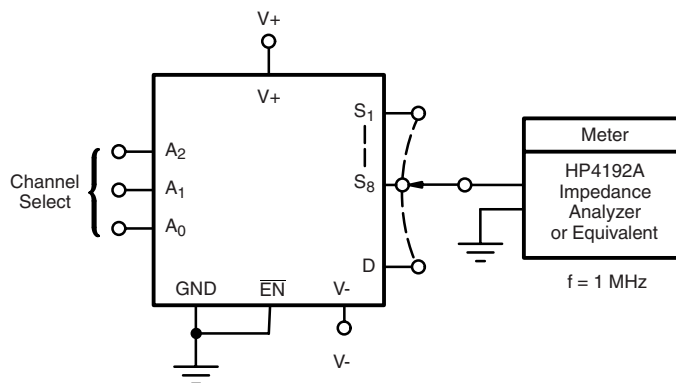
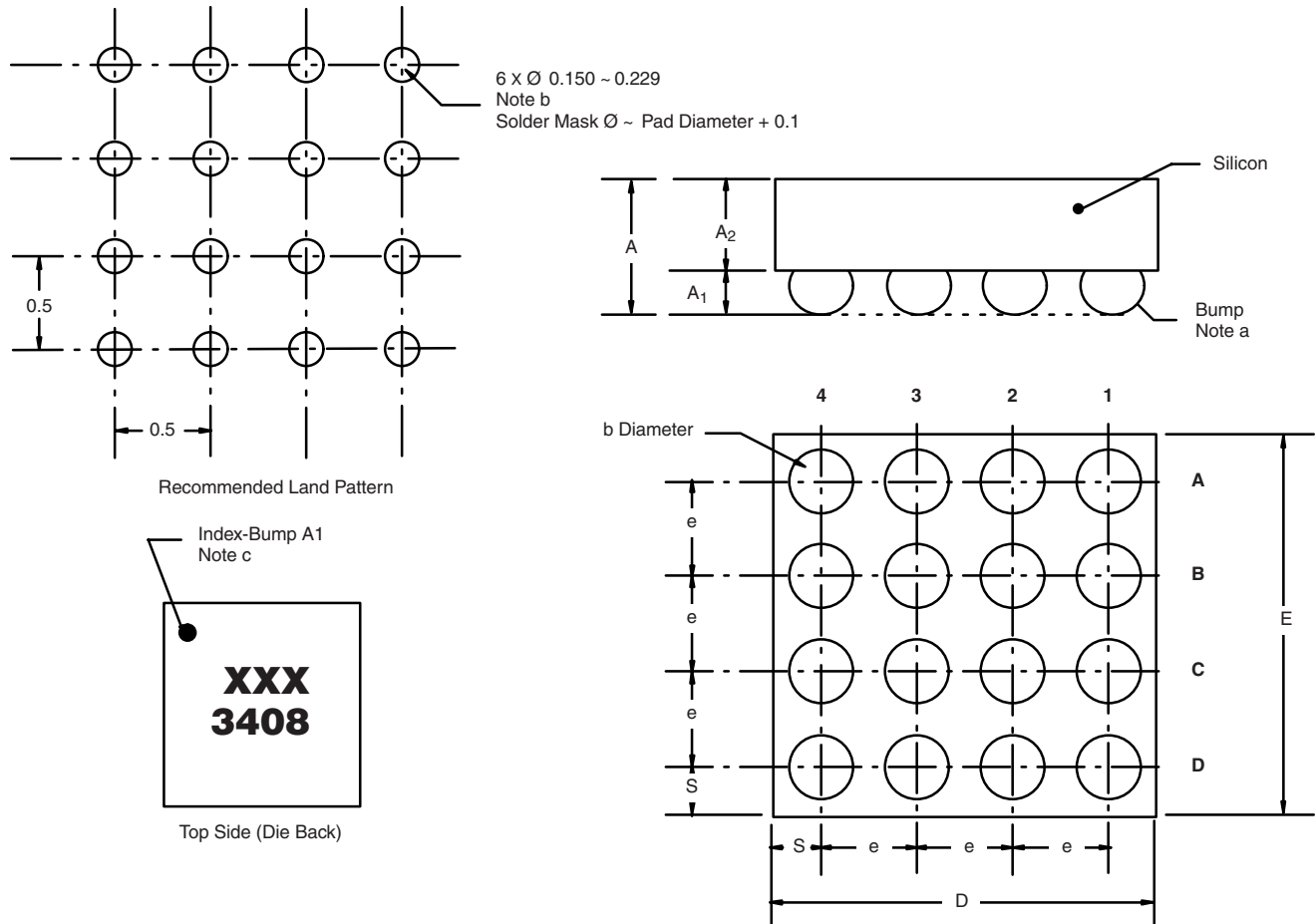

Figure 9. Source Drain Capacitance

PACKAGE OUTLINE
MICRO FOOT: 16-BUMP (4 x 4, 0.5 mm PITCH, 0.238 mm BUMP HEIGHT)

Notes (Unless Otherwise Specified):

- a. Bump is Lead Free Sn/Ag/Cu.
- b. Non-solder mask defined copper landing pad.
- c. Laser Mark on silicon die back; back-lapped, no coating. Shown is not actual marking; sample only.

Dim	Millimeters ^a		Inches	
	Min	Max	Min	Max
A	0.688	0.753	0.0271	0.0296
A₁	0.218	0.258	0.0086	0.0102
A₂	0.470	0.495	0.0185	0.0195
b	0.306	0.346	0.0120	0.0136
D	1.980	2.020	0.0780	0.0795
E	1.980	2.020	0.0780	0.0795
e	0.5 BASIC		0.0197 BASIC	
S	0.230	0.270	0.0091	0.0106

Notes:

- a. Use millimeters as the primary measurement.

Vishay Siliconix maintains worldwide manufacturing capability. Products may be manufactured at one of several qualified locations. Reliability data for Silicon Technology and Package Reliability represent a composite of all qualified locations. For related documents such as package/tape drawings, part marking, and reliability data, see <http://www.vishay.com/ppg?72858>.



Disclaimer

All product specifications and data are subject to change without notice.

Vishay Intertechnology, Inc., its affiliates, agents, and employees, and all persons acting on its or their behalf (collectively, "Vishay"), disclaim any and all liability for any errors, inaccuracies or incompleteness contained herein or in any other disclosure relating to any product.

Vishay disclaims any and all liability arising out of the use or application of any product described herein or of any information provided herein to the maximum extent permitted by law. The product specifications do not expand or otherwise modify Vishay's terms and conditions of purchase, including but not limited to the warranty expressed therein, which apply to these products.

No license, express or implied, by estoppel or otherwise, to any intellectual property rights is granted by this document or by any conduct of Vishay.

The products shown herein are not designed for use in medical, life-saving, or life-sustaining applications unless otherwise expressly indicated. Customers using or selling Vishay products not expressly indicated for use in such applications do so entirely at their own risk and agree to fully indemnify Vishay for any damages arising or resulting from such use or sale. Please contact authorized Vishay personnel to obtain written terms and conditions regarding products designed for such applications.

Product names and markings noted herein may be trademarks of their respective owners.