

To all our customers

Regarding the change of names mentioned in the document, such as Mitsubishi Electric and Mitsubishi XX, to Renesas Technology Corp.

The semiconductor operations of Hitachi and Mitsubishi Electric were transferred to Renesas Technology Corporation on April 1st 2003. These operations include microcomputer, logic, analog and discrete devices, and memory chips other than DRAMs (flash memory, SRAMs etc.) Accordingly, although Mitsubishi Electric, Mitsubishi Electric Corporation, Mitsubishi Semiconductors, and other Mitsubishi brand names are mentioned in the document, these names have in fact all been changed to Renesas Technology Corp. Thank you for your understanding. Except for our corporate trademark, logo and corporate statement, no changes whatsoever have been made to the contents of the document, and these changes do not constitute any alteration to the contents of the document itself.

Note : Mitsubishi Electric will continue the business operations of high frequency & optical devices and power devices.

Renesas Technology Corp.
Customer Support Dept.
April 1, 2003

MITSUBISHI INSULATED GATE BIPOLAR TRANSISTOR

CT40TMH-8

STROBE FLASHER USE

CT40TMH-8



- VCES 400V
- ICM 200A

OUTLINE DRAWING

Dimensions in mm

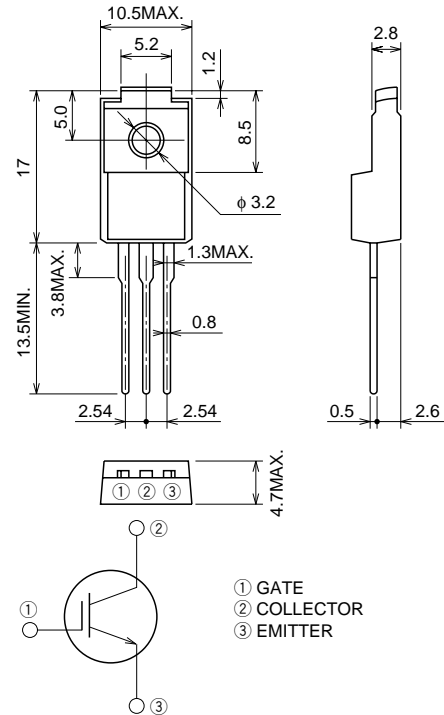

TO-220F

APPLICATION

Strobe Flasher.

MAXIMUM RATINGS (Tc = 25°C)

| Symbol | Parameter | Conditions | Ratings | Unit |
|-------------------|----------------------------|---------------------------------------------|------------|------|
| V _{CE} S | Collector-emitter voltage | V _{GE} = 0V | 400 | V |
| V _{GE} S | Gate-emitter voltage | V _{CE} = 0V, See notice 4 | ±30 | V |
| V _{GEM} | Peak gate-emitter voltage | V _{CE} = 0V, t _w = 0.5s | ±40 | V |
| I _{CM} | Collector current (Pulsed) | See figure 1 | 200 | A |
| T _j | Junction temperature | | -40 ~ +150 | °C |
| T _{stg} | Storage temperature | | -40 ~ +150 | °C |

ELECTRICAL CHARACTERISTICS (T_j = 25°C)

| Symbol | Parameter | Test conditions | Limits | | | Unit |
|---------------------|-------------------------------------|----------------------------------------------|--------|------|------|------|
| | | | Min. | Typ. | Max. | |
| V(BR)CES | Collector-emitter breakdown voltage | I _C = 1mA, V _{GE} = 0V | 450 | — | — | V |
| I _{CES} | Collector-emitter leakage current | V _{CE} = 400V, V _{GE} = 0V | — | — | 10 | μA |
| I _{GES} | Gate-emitter leakage current | V _{GE} = ±40V, V _{CE} = 0V | — | — | ±0.1 | μA |
| V _{GE(th)} | Gate-emitter threshold voltage | V _{CE} = 10V, I _C = 1mA | — | — | 7.0 | V |

Feb.1999

PERFORMANCE CURVES

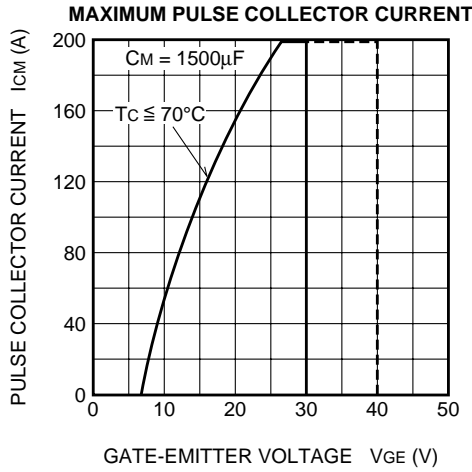
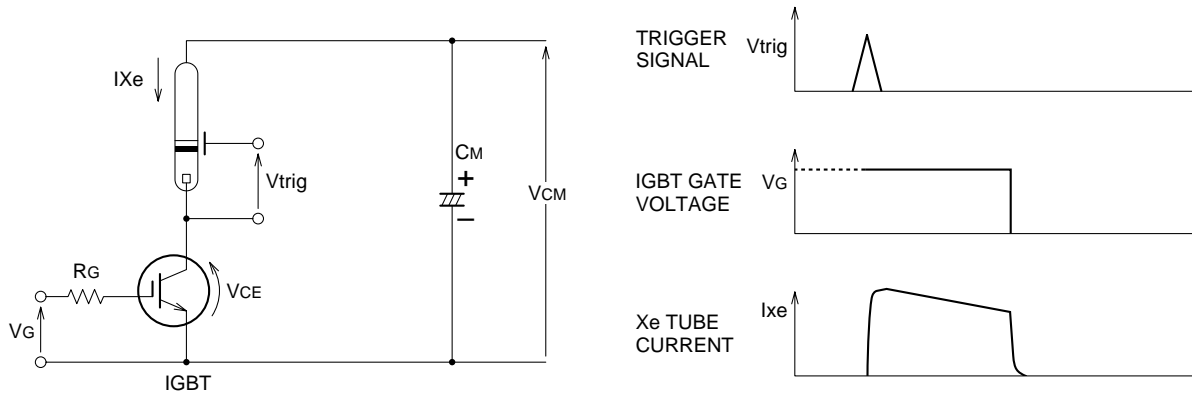

Figure 1

APPLICATION EXAMPLE



| RECOMMEND CONDITION | MAXIMUM CONDITION |
|---------------------|-------------------|
| $V_{CM} = 330V$ | 350V |
| $I_P = 180A$ | 200A |
| $C_M = 1200\mu F$ | 1500 μF |
| $V_{GE} = 28V$ | |

- Notice 1. Gate drive voltage during on-period must be applied to satisfy the rating of maximum pulse collector current. And reverse gate current during turn-off must be kept less than 1A. (In general, it is satisfied if $R_G \geq 30\Omega$)
- Notice 2. IGBT has MOS structure and its gate is insulated by thin silicon oxide. So please handle carefully not to suffer from electrostatic charge.
- Notice 3. The operation life should be endured 5,000 shots under the charge current ($I_{xe} \leq 200A$: full luminescence condition) of main condenser ($C_M=1500\mu F$). Repetition period under full luminescence condition is over 3 seconds.
- Notice 4. Total operation hours must be applied within 5,000 hours.