

Silicon NPN Darlington Power Transistors

BD675/BD677/BD679

DESCRIPTION

- With TO-126 package
- Complement to type BD676/678/680
- DARLINGTON
- High DC current gain

APPLICATIONS

- For use as output devices in complementary general-purpose amplifier applications

PINNING

PIN	DESCRIPTION
1	Emitter
2	Collector;connected to mounting base
3	Base

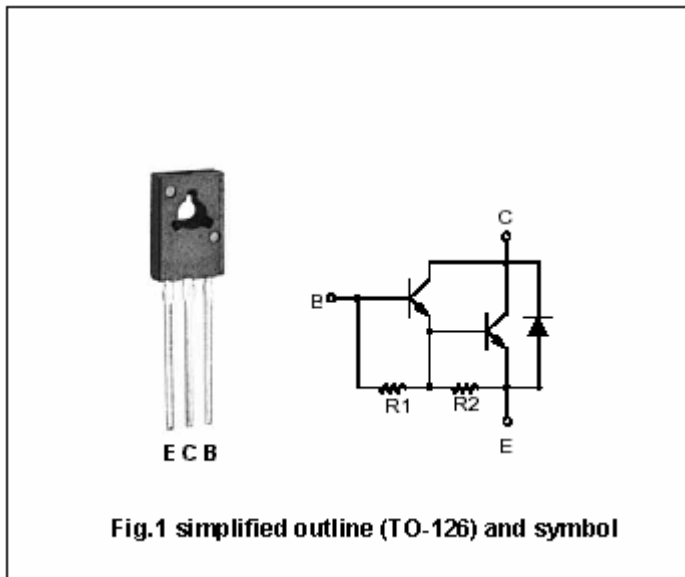

Fig.1 simplified outline (TO-126) and symbol

Absolute maximum ratings (Ta=25)

SYMBOL	PARAMETER	CONDITIONS	VALUE	UNIT
V _{CBO}	Collector-base voltage	BD675	45	V
		BD677	60	
		BD679	80	
V _{CEO}	Collector-emitter voltage	BD675	45	V
		BD677	60	
		BD679	80	
V _{EBO}	Emitter -base voltage	Open collector	5	V
I _C	Collector current		4	A
I _{CM}	Collector current-Peak		7	A
I _B	Base current		0.1	A
P _C	Collector power dissipation	T _C =25	40	W
T _j	Junction temperature		150	
T _{stg}	Storage temperature		-55~150	

THERMAL CHARACTERISTICS

SYMBOL	PARAMETER	VALUE	UNIT
R _{th j-a}	Thermal resistance from junction to ambient	100	K/W
R _{th j-mb}	Thermal resistance from junction to mounting base	3.12	K/W

Silicon NPN Darlington Power Transistors

BD675/BD677/BD679

CHARACTERISTICS

T_j=25 unless otherwise specified

SYMBOL	PARAMETER	CONDITIONS	MIN	TYP.	MAX	UNIT
V _{(BR)CEO}	Collector-emitter breakdown voltage	BD675	I _C =100mA; I _B =0	45		V
		BD677		60		
		BD679		80		
V _{(BR)CBO}	Collector-base breakdown voltage	BD675	I _C =1mA; I _E =0	45		V
		BD677		60		
		BD679		80		
V _{(BR)EBO}	Emitter-base breakdown voltage	I _E =5mA; I _C =0	5			V
V _{CEsat}	Collector-emitter saturation voltage	I _C =1.5A; I _B =30mA			2.5	V
V _{BE(on)}	Base-emitter on voltage	I _C =1.5A; V _{CE} =3V			2.5	V
I _{CBO}	Collector cut-off current	V _{CB} =rated BV _{CBO} ; I _E =0 T _a =100			0.2 2.0	mA
I _{CEO}	Collector cut-off current	V _{CE} =1/2rated BV _{CEO} ; I _B =0			0.5	mA
I _{EBO}	Emitter cut-off current	V _{EB} =5V; I _C =0			5.0	mA
h _{FE}	DC current gain	I _C =1.5A; V _{CE} =3V	750			

PACKAGE OUTLINE

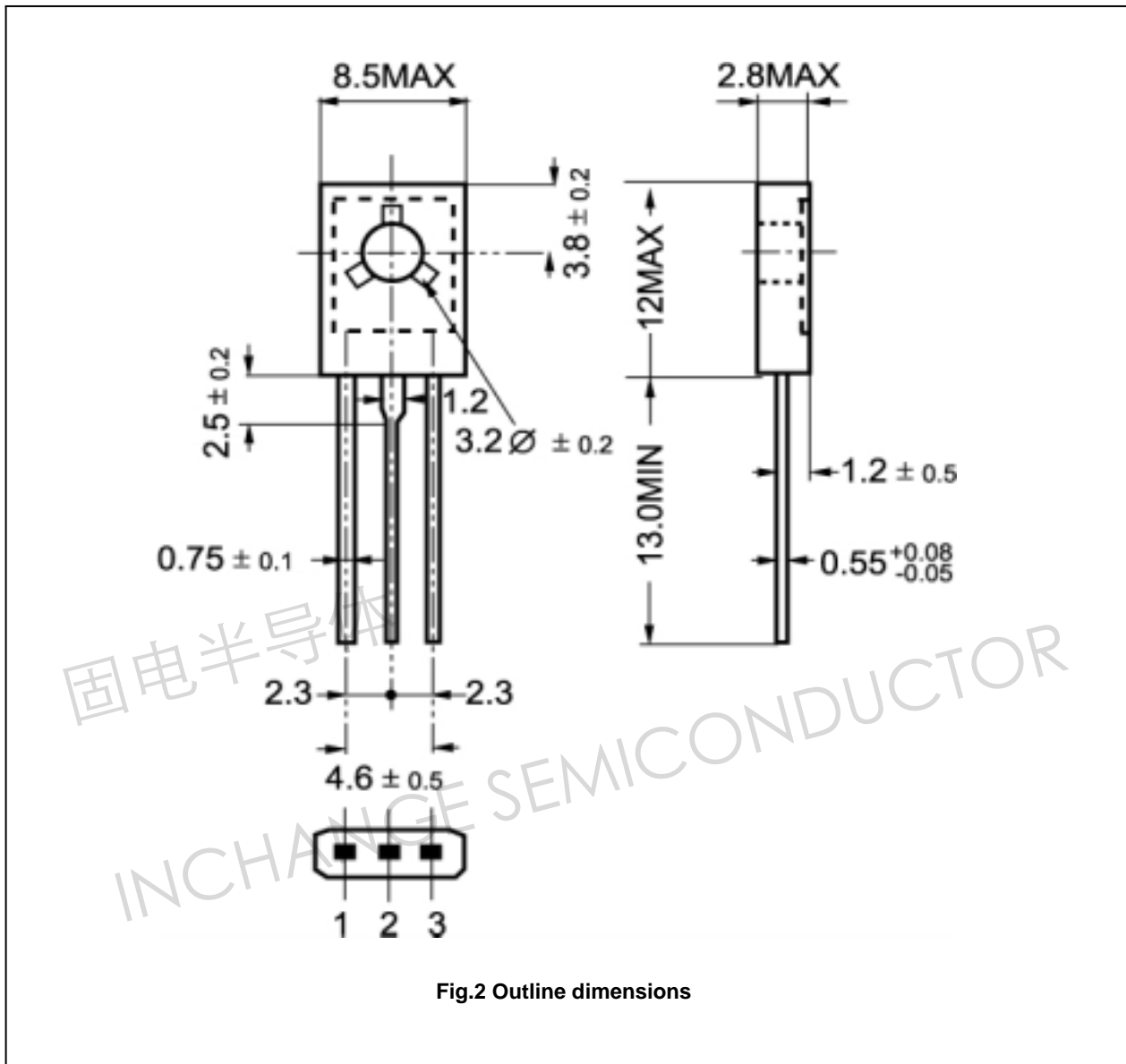

Fig.2 Outline dimensions