

Silicon NPN Power Transistors

2SD1632

DESCRIPTION

- With TO-3PFa package
- High voltage ,high speed
- Built-in damper diode
- Wide area of safe operation

APPLICATIONS

- For horizontal deflection output applications

PINNING

PIN	DESCRIPTION
1	Base
2	Collector
3	Emitter

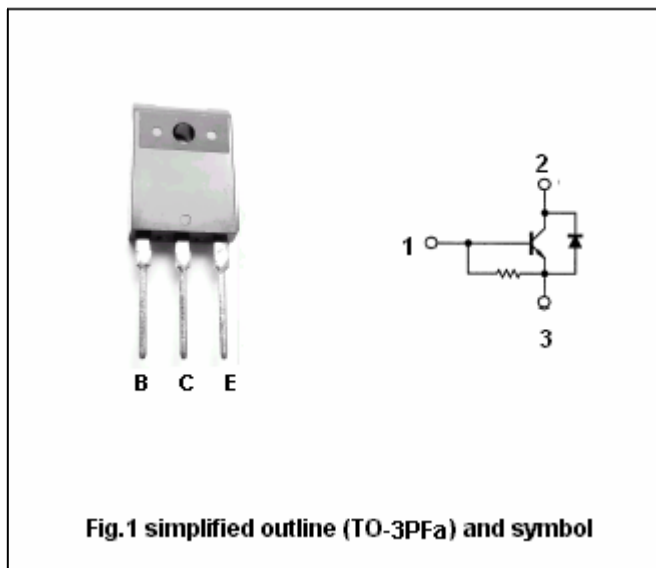

Fig.1 simplified outline (TO-3PFa) and symbol

Absolute maximum ratings(Ta=25°C)

SYMBOL	PARAMETER	CONDITIONS	VALUE	UNIT
V _{CBO}	Collector-base voltage	Open emitter	1500	V
V _{EBO}	Emitter-base voltage	Open collector	5	V
I _C	Collector current		4	A
I _{CM}	Collector current-peak		15	A
I _{BM}	Base current		3.5	A
P _C	Collector power dissipation	T _C =25°C	70	W
T _j	Junction temperature		130	°C
T _{stg}	Storage temperature		-55~130	°C

Silicon NPN Power Transistors

2SD1632

CHARACTERISTICS

T_j=25°C unless otherwise specified

SYMBOL	PARAMETER	CONDITIONS	MIN	TYP.	MAX	UNIT
V _{(BR)EBO}	Emitter-base breakdown voltage	I _E =500mA ; I _C =0	5			V
V _{CEsat}	Collector-emitter saturation voltage	I _C =3A ; I _B =1A			1.0	V
V _{BEsat}	Base-emitter saturation voltage	I _C =3A ; I _B =1A			1.5	V
I _{CBO}	Collector cut-off current	V _{CB} =750V; I _E =0			50	μA
		V _{CB} =1500V; I _E =0			1	mA
h _{FE}	DC current gain	I _C =3A ; V _{CE} =10V	5		15	
V _F	Diode forward voltage	I _C =-4A			2.2	V

Switching times

t _{stg}	Storage time	I _C =3A I _{Bend} =1A; L _{Leak} =5μH	4		9	μs
t _f	Fall time				0.8	μs

Silicon NPN Power Transistors

2SD1632

PACKAGE OUTLINE

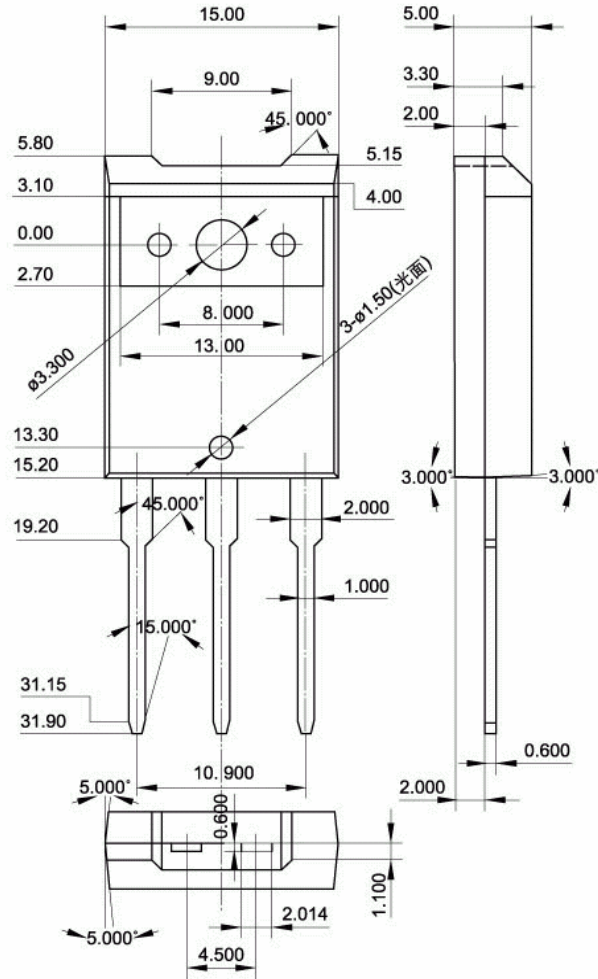

Fig.2 Outline dimensions (unindicated tolerance:±0.30mm)