

isc Silicon NPN Power Transistor

2SC4008

DESCRIPTION

- Low Collector Saturation Voltage
: $V_{CE(sat)} = 1.0V(\text{Max}) @ I_C = 2A$
- Collector-Emmitter Breakdown Voltage-
: $V_{(BR)CEO} = 80V (\text{Min})$
- Wide Area of Safe Operation
- Complement to Type 2SA1635

APPLICATIONS

- Designed for audio and general purpose applications

ABSOLUTE MAXIMUM RATINGS($T_a=25^\circ C$)

SYMBOL	PARAMETER	VALUE	UNIT
V_{CBO}	Collector-Base Voltage	100	V
V_{CEO}	Collector-Emmitter Voltage	80	V
V_{EBO}	Emmitter-Base Voltage	6	V
I_C	Collector Current-Continuous	4	A
I_{CM}	Collector Current-Peak	6	A
P_C	Collector Power Dissipation @ $T_C=25^\circ C$	30	W
	Collector Power Dissipation @ $T_a=25^\circ C$	2	
T_J	Junction Temperature	150	$^\circ C$
T_{stg}	Storage Temperature Range	-55~150	$^\circ C$

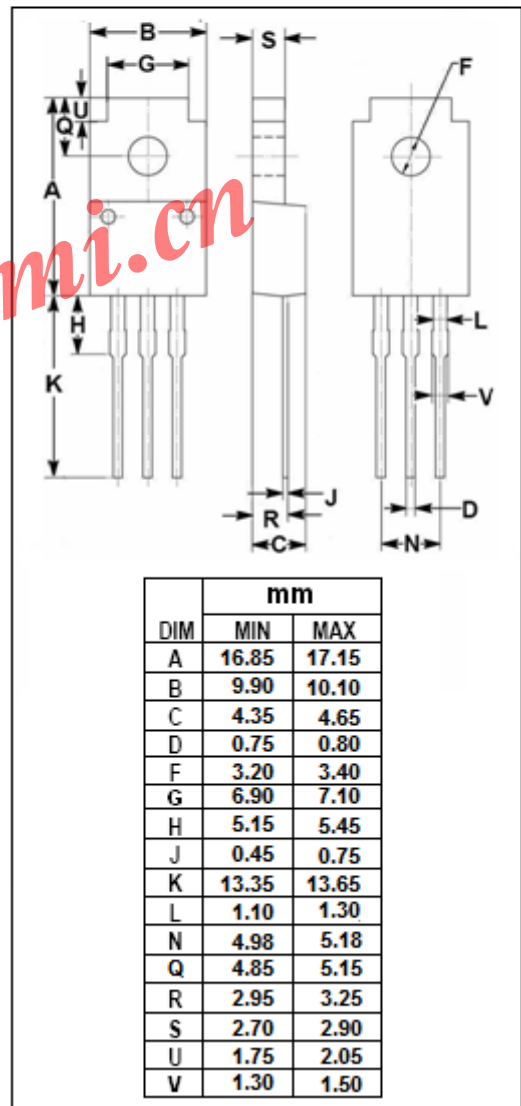
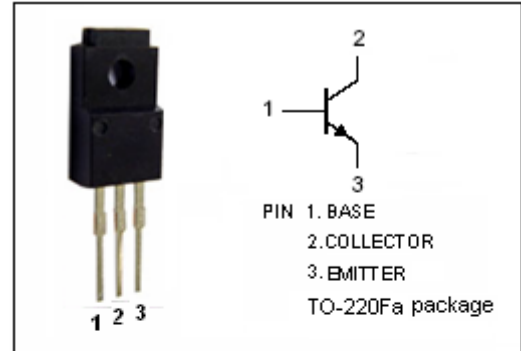

isc Silicon NPN Power Transistor**2SC4008****ELECTRICAL CHARACTERISTICS** $T_C=25^{\circ}\text{C}$ unless otherwise specified

SYMBOL	PARAMETER	CONDITIONS	MIN	TYP.	MAX	UNIT
$V_{(BR)CBO}$	Collector-Base Breakdown Voltage	$I_C=50\ \mu\text{A}; I_E=0$	100			V
$V_{(BR)CEO}$	Collector-Emitter Breakdown Voltage	$I_C=25\text{mA}; I_B=0$	80			V
$V_{(BR)EBO}$	Emitter-Base Breakdown Voltage	$I_E=50\ \mu\text{A}; I_C=0$	6			V
$V_{CE(sat)}$	Collector-Emitter Saturation Voltage	$I_C=2\text{A}; I_B=0.2\text{A}$			1.0	V
$V_{BE(sat)}$	Base-Emitter Saturation Voltage	$I_C=2\text{A}; I_B=0.2\text{A}$			1.5	V
I_{CBO}	Collector Cutoff Current	$V_{CB}=100\text{V}; I_E=0$			10	μA
I_{EBO}	Emitter Cutoff Current	$V_{EB}=6\text{V}; I_C=0$			10	μA
h_{FE}	DC Current Gain	$I_C=1\text{A}; V_{CE}=4\text{V}$	100		500	
f_T	Current-Gain—Bandwidth Product	$I_E=-0.2\text{A}; V_{CE}=12\text{V}$		10		MHz
C_{OB}	Output Capacitance	$I_E=0; V_{CB}=10\text{V}; f_{test}=1\text{MHz}$		60		pF

◆ **h_{FE} classifications**

E	F	G
100-200	160-320	250-500