

**Silicon NPN Power Transistors**

**2SC3025**

**DESCRIPTION**

- With TO-3 package
- High breakdown voltage

**APPLICATIONS**

- High voltage power switching character display horizontal deflection output

**PINNING(see Fig.2)**

PIN	DESCRIPTION
1	Base
2	Emitter
3	Collector

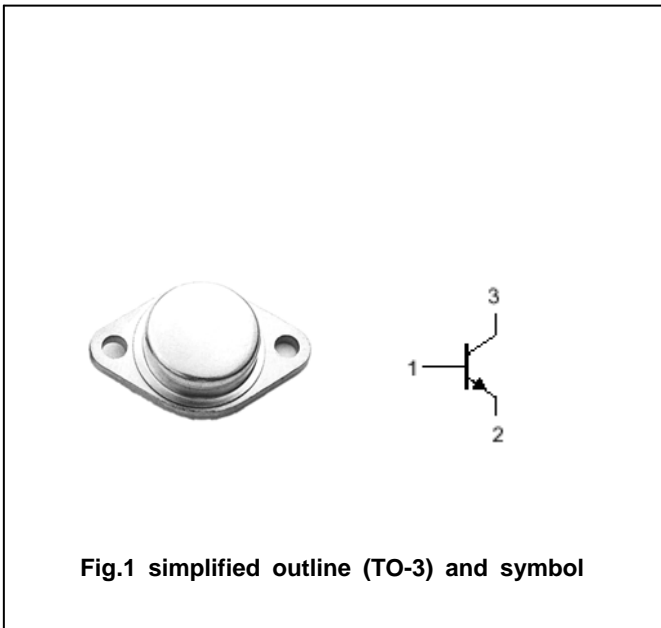

Fig.1 simplified outline (TO-3) and symbol

**ABSOLUTE MAXIMUM RATINGS(T<sub>a</sub>=25°C)**

SYMBOL	PARAMETER	CONDITIONS	VALUE	UNIT
V <sub>CBO</sub>	Collector-base voltage	Open emitter	1500	V
V <sub>CEO</sub>	Collector-emitter voltage	Open base	800	V
V <sub>EBO</sub>	Emitter-base voltage	Open collector	6	V
I <sub>C</sub>	Collector current		5	A
I <sub>CP</sub>	Collector current-peak		6	A
P <sub>C</sub>	Collector power dissipation	T <sub>C</sub> =25°C	50	W
T <sub>j</sub>	Junction temperature		150	°C
T <sub>stg</sub>	Storage temperature		-45~150	°C

## Silicon NPN Power Transistors

## 2SC3025

## CHARACTERISTICS

T<sub>j</sub>=25°C unless otherwise specified

SYMBOL	PARAMETER	CONDITIONS	MIN	TYP.	MAX	UNIT
V <sub>(BR)CEO</sub>	Collector-emitter breakdown voltage	I <sub>C</sub> =10mA ; R <sub>BE</sub> =∞	800			V
V <sub>(BR)EBO</sub>	Emitter-base breakdown voltage	I <sub>E</sub> =10mA; I <sub>C</sub> =0	6			V
V <sub>CE(sat)</sub>	Collector-emitter saturation voltage	I <sub>C</sub> =5A; I <sub>B</sub> =1.25A			2.0	V
V <sub>BE(sat)</sub>	Base-emitter saturation voltage	I <sub>C</sub> =5A; I <sub>B</sub> =1.25A			1.5	V
I <sub>CES</sub>	Collector cut-off current	V <sub>CE</sub> =1500V; R <sub>BE</sub> =∞			0.5	mA

## Switching times

t <sub>s</sub>	Storage time	I <sub>C</sub> =5A; I <sub>B1</sub> =1A; I <sub>B2</sub> =-2.5A		4.0		μ s
t <sub>f</sub>	Fall time				0.5	μ s

PACKAGE OUTLINE

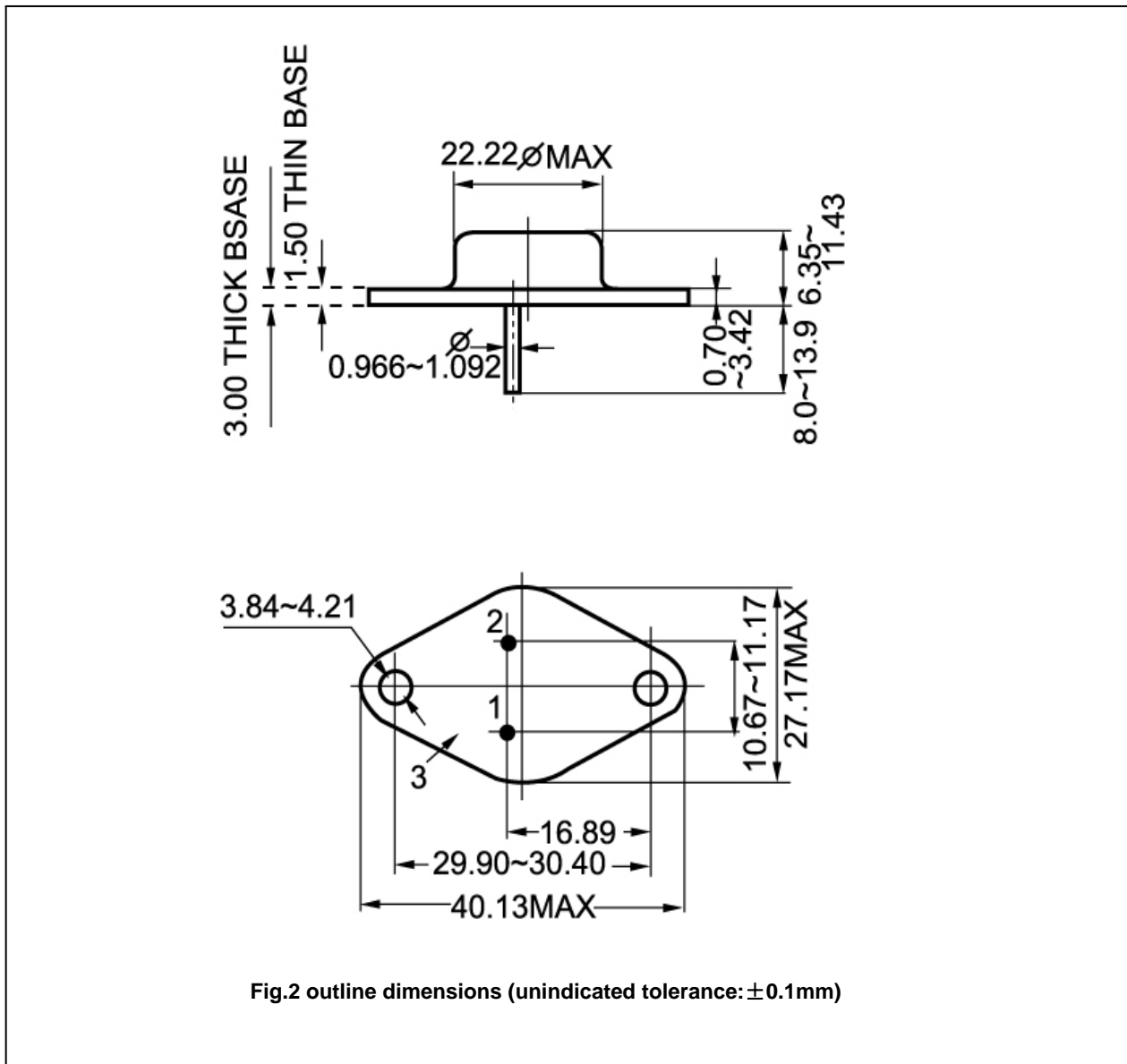

Fig.2 outline dimensions (unindicated tolerance:  $\pm 0.1$ mm)