

Guard Locking Interlocks

TLS1-GD2, Bulletin 800, CU1, Bulletin 100, Dual Channel

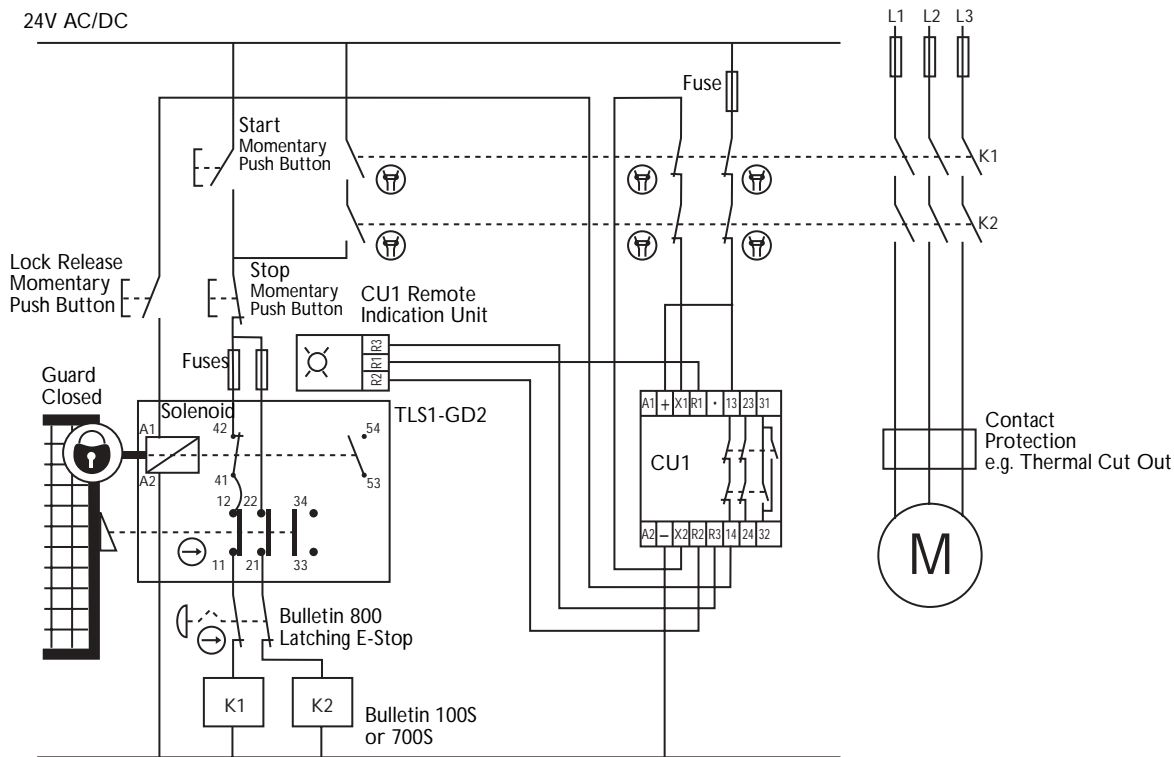

Circuit Status

Circuit shown with guard door closed and locked (solenoid not energized), ready for motor starting (push start button) or lock release (push lock release button).

Operating Principle

In this system the guard is locked closed until the solenoid is energized.

The solenoid can only be energized when:

- The auxiliary contacts at K1 and K2 are closed. Therefore power contacts at KI & K2 are open.
- The CU1 control unit has timed out for a pre-set period.

At this stage the remote indication unit will show that the guard can now be opened by operating the lock release push button.

When the locking mechanism is released, monitoring contacts 41-42 are opened. These contacts are in series with the contactor (K1) control circuit and will therefore prevent restart while the TLS1-GD2 is in the unlocked mode. If the guard is opened, contacts 11-12 and 21-22 are opened and will prevent restart while the guard is open regardless of the lock status.

Fault Detection

If either contactor K1 or K2 sticks ON - the motor will stop but the guard cannot be opened (thus the fault is revealed to the operator).

A short circuit fault on the solenoid energization circuit will initiate a STOP via contacts 41-42.

A single fault within the CU1 will prevent the closing of its outputs (preventing solenoid energization).

A short circuit fault across either terminals 11-42 or terminals 21-22 will not be detected but the motor cannot be started while the guard is open.

A single short circuit fault across the E-Stop device will not be detected but will not prevent emergency stopping.

An open circuit fault on the solenoid energization circuit will prevent guard opening (other than by the emergency release points on the TLS-GD2).

Comments

This system is a practical and effective method of providing an interlock function of increased integrity. It is suitable for applications where motion overruns after the stop command and the time taken to run down to a stop is predictable, consistent and less than approx. 30 minutes. The inclusion of the lock release push button means that the solenoid is only energized when guard opening is required. This prevents guard doors from swinging open whenever the control stop button is pressed. It also means that the solenoid is not left energized for long periods which can cause efficiency loss. The solenoids used in the Atlas and TLS-GD2 are continuously rated but, as with any solenoid, their action will be more positive when they are working at maximum possible efficiency.

