

To all our customers

Regarding the change of names mentioned in the document, such as Mitsubishi Electric and Mitsubishi XX, to Renesas Technology Corp.

The semiconductor operations of Hitachi and Mitsubishi Electric were transferred to Renesas Technology Corporation on April 1st 2003. These operations include microcomputer, logic, analog and discrete devices, and memory chips other than DRAMs (flash memory, SRAMs etc.) Accordingly, although Mitsubishi Electric, Mitsubishi Electric Corporation, Mitsubishi Semiconductors, and other Mitsubishi brand names are mentioned in the document, these names have in fact all been changed to Renesas Technology Corp. Thank you for your understanding. Except for our corporate trademark, logo and corporate statement, no changes whatsoever have been made to the contents of the document, and these changes do not constitute any alteration to the contents of the document itself.

Note : Mitsubishi Electric will continue the business operations of high frequency & optical devices and power devices.

Renesas Technology Corp.
Customer Support Dept.
April 1, 2003

CT30SM-12

GENERAL INVERTER • UPS USE

CT30SM-12



- VCES 600V
- IC 30A
- High Speed Switching
- Low VCE Saturation Voltage

OUTLINE DRAWING

Dimensions in mm

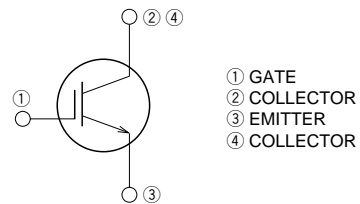
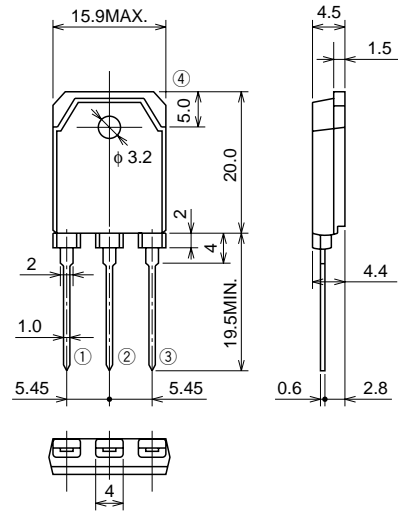

TO-3P

APPLICATION

AC & DC motor controls, General purpose inverters, UPS, Power supply switching, Servo controls, etc.

MAXIMUM RATINGS (Tc = 25°C)

Symbol	Parameter	Conditions	Ratings	Unit
V _{CE} S	Collector-emitter voltage	V _{GE} = 0V	600	V
V _{GES}	Gate-emitter voltage	V _{CE} = 0V	±20	V
V _{GEM}	Peak gate-emitter voltage	V _{CE} = 0V	±30	V
I _C	Collector current		30	A
I _{CM}	Collector current (Pulsed)		60	A
P _C	Maximum power dissipation		250	W
T _j	Junction temperature		-40 ~ +150	°C
T _{stg}	Storage temperature		-40 ~ +150	°C
—	Weight	Typical value	4.8	g

ELECTRICAL CHARACTERISTICS ($T_j = 25^\circ\text{C}$)

Symbol	Parameter	Test conditions	Limits			Unit
			Min.	Typ.	Max.	
V (BR) CES	Collector-emitter breakdown voltage	$I_C = 1\text{mA}, V_{GE} = 0\text{V}$	600	—	—	V
I _{GES}	Collector-emitter leakage current	$V_{GE} = \pm 30\text{V}, V_{CE} = 0\text{V}$	—	—	± 0.5	μA
I _{CES}	Gate-emitter leakage current	$V_{CE} = 600\text{V}, V_{GE} = 0\text{V}$	—	—	1	mA
V _{GE(th)}	Gate-emitter threshold voltage	$I_C = 3.0\text{mA}, V_{CE} = 10\text{V}$	4.5	6.0	7.5	V
V _{CE(sat)}	Collector-emitter saturation voltage	$I_C = 30\text{A}, V_{GE} = 15\text{V}$	—	2.5	3.0	V
C _{ies}	Input capacitance	$V_{CE} = 25\text{V}, V_{GE} = 0\text{V}, f = 1\text{MHz}$	—	1480	—	pF
C _{oes}	Output capacitance		—	180	—	pF
C _{res}	Reverse transfer capacitance		—	54	—	pF
t _{d (on)}	Turn-on delay time	$V_{CC} = 300\text{V}, \text{Resistance load}, I_C = 30\text{A}, V_{GE} = 15\text{V}, R_{GE} = 20\Omega$	—	30	—	ns
t _r	Rise time		—	135	—	ns
t _{d (off)}	Turn-off delay time		—	135	—	ns
t _f	Fall time		—	250	—	ns
R _{th (j-c)}	Thermal resistance	Junction to case	—	—	0.50	$^\circ\text{C/W}$

PERFORMANCE CURVES

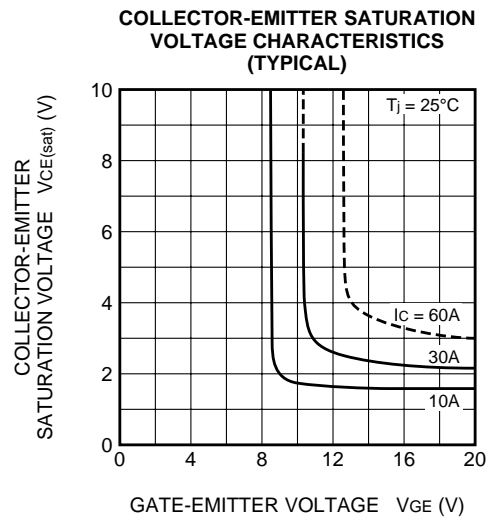
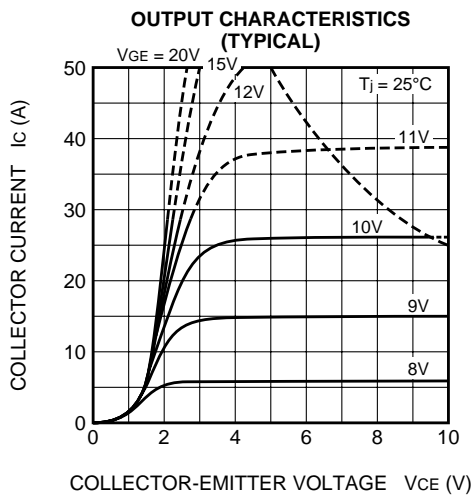

COLLECTOR-EMITTER SATURATION VOLTAGE CHARACTERISTICS (TYPICAL)

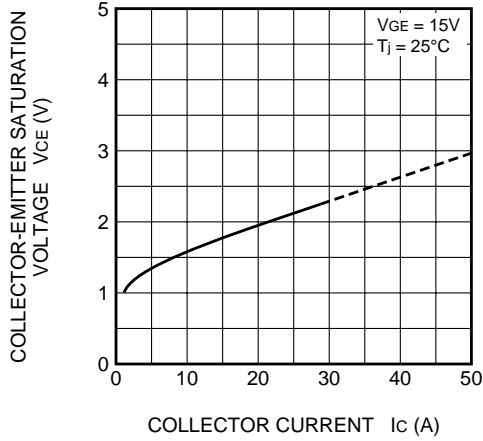

COLLECTOR CURRENT VS. GATE-EMITTER VOLTAGE CHARACTERISTIC (TYPICAL)

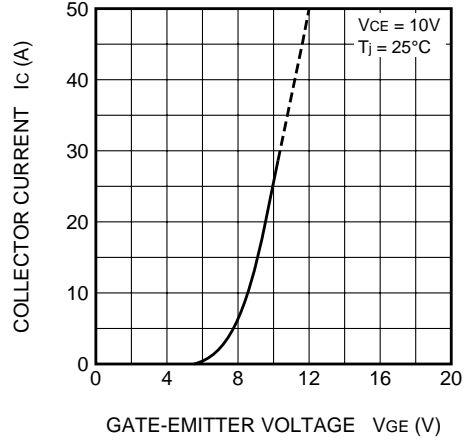

CAPACITANCE VS. COLLECTOR-EMITTER VOLTAGE CHARACTERISTIC (TYPICAL)

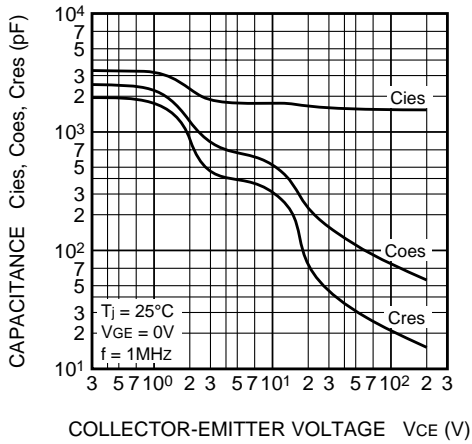

SWITCHING TIME-COLLECTOR CURRENT CHARACTERISTIC (TYPICAL)

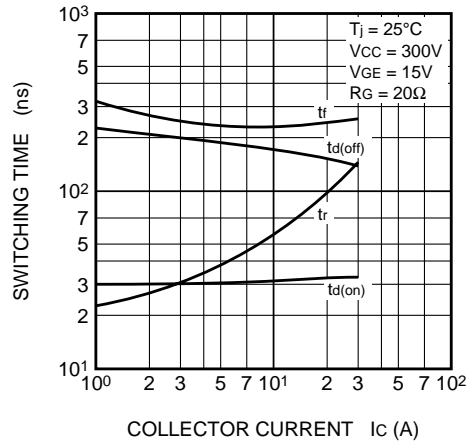

GATE-EMITTER VOLTAGE VS. GATE CHARGE CHARACTERISTIC (TYPICAL)

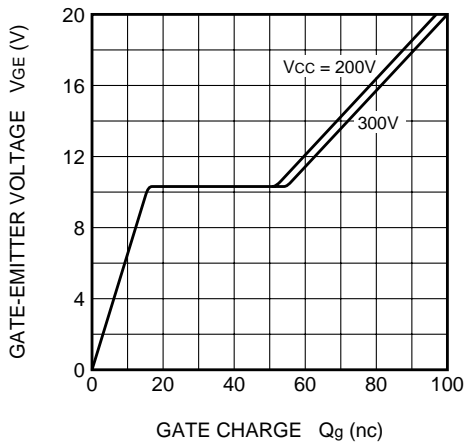

TRANSIENT THERMAL IMPEDANCE CHARACTERISTICS (TYPICAL)

