

Silicon NPN Power Transistors

2SC2525

DESCRIPTION

- With MT-200 package
- Complement to type 2SA1075
- Excellent safe operating area
- Ultra fast switching speed

APPLICATIONS

- Suited for high frequency power amplifiers, audio power amplifiers, switching regulators and DC-DC converters applications

PINNING(see Fig.2)

PIN	DESCRIPTION
1	Base
2	Collector;connected to mounting base
3	Emitter

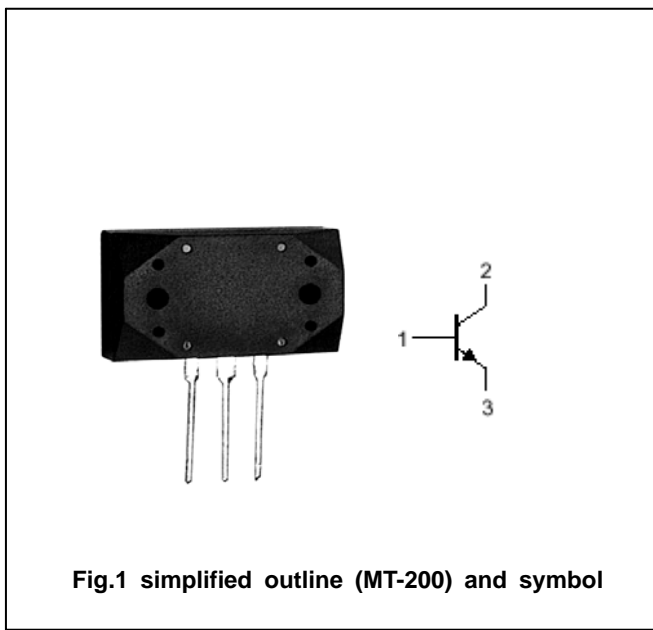

Absolute maximum ratings(Ta=25°C)

SYMBOL	PARAMETER	CONDITIONS	VALUE	UNIT
V _{CBO}	Collector-base voltage	Open emitter	120	V
V _{CEO}	Collector-emitter voltage	Open base	120	V
V _{EBO}	Emitter-base voltage	Open collector	7	V
I _C	Collector current		12	A
P _C	Collector power dissipation	T _C =25°C	120	W
T _j	Junction temperature		150	°C
T _{stg}	Storage temperature		-65~150	°C

Silicon NPN Power Transistors

2SC2525

CHARACTERISTICS

T_j=25°C unless otherwise specified

SYMBOL	PARAMETER	CONDITIONS	MIN	TYP.	MAX	UNIT
V _{(BR)CEO}	Collector-emitter breakdown voltage	I _C =1mA; R _{BE} =∞	120			V
V _{(BR)CBO}	Collector-base breakdown voltage	I _C =50 μ A; I _E =0	120			V
V _{(BR)EBO}	Emitter-base breakdown voltage	I _E =50 μ A; I _C =0	7			V
V _{CEsat}	Collector-emitter saturation voltage	I _C =5 A; I _B =0.5 A		0.7	1.8	V
V _{BE}	Base-emitter voltage	I _C =5A ; V _{CE} =5V		1.25	1.7	V
I _{CBO}	Collector cut-off current	V _{CB} =120V; I _E =0			50	μ A
I _{EBO}	Emitter cut-off current	V _{EB} =7V; I _C =0			50	μ A
h _{FE-1}	DC current gain	I _C =1A ; V _{CE} =5V	60		200	
h _{FE-2}	DC current gain	I _C =7A ; V _{CE} =5V	40			
f _T	Transition frequency	I _C =1A ; V _{CB} =10V,f=1MHz	50	80		MHz
C _{OB}	Output capacitance	I _E =0; V _{CB} =10V;f=1MHz		180	300	pF

Switching times

t _r	Rise time	I _C =7.5A; R _L =4 Ω I _{B1} =-I _{B2} =0.75A		0.3		μ s
t _s	Storage time			1.3		μ s
t _f	Fall time			0.2		μ s

PACKAGE OUTLINE

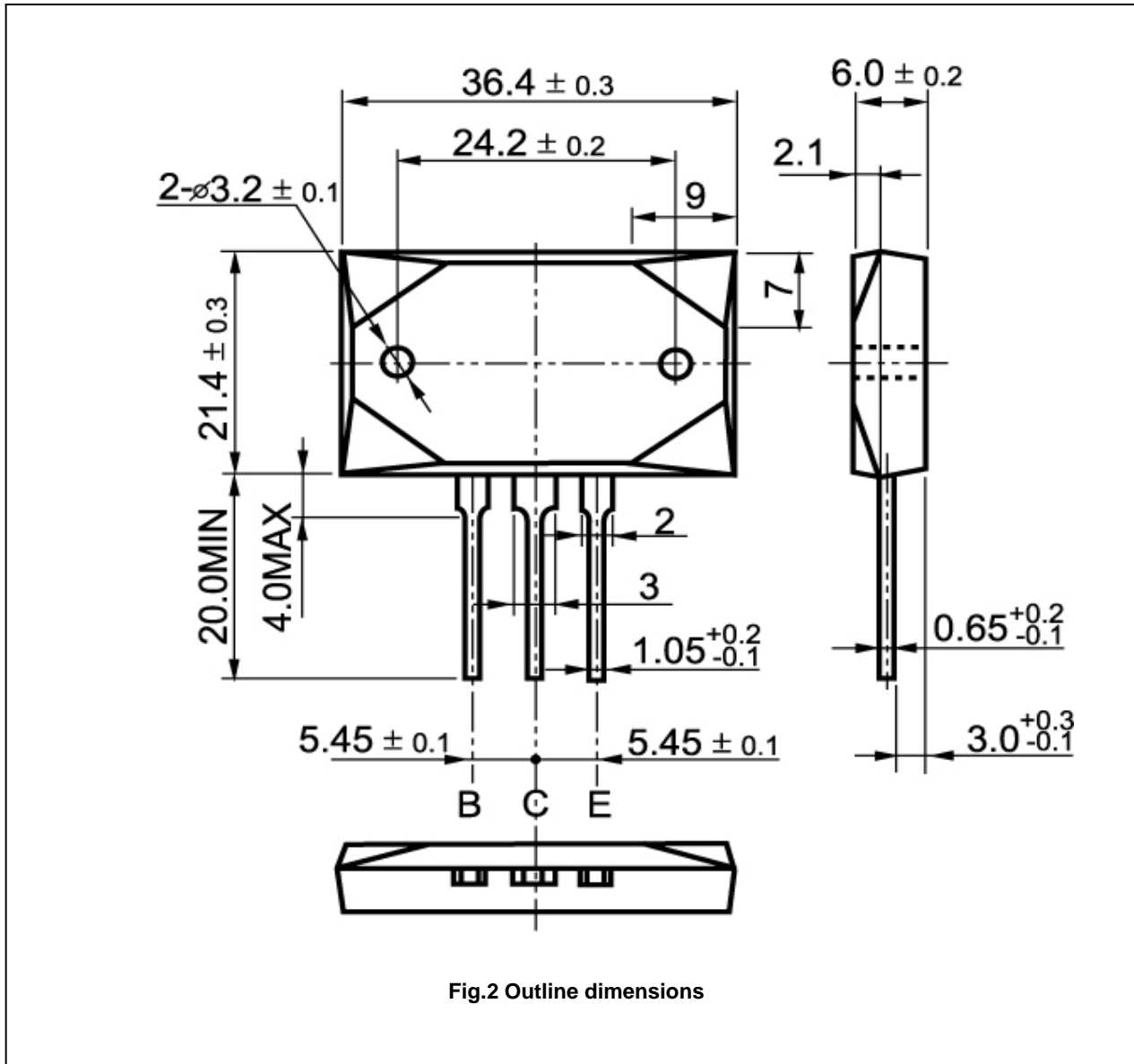

Fig.2 Outline dimensions