

Silicon NPN Power Transistors

BD675A/677A/679A/681

DESCRIPTION

- With TO-126 package
- Complement to type BD676A/678A/680A/682
- DARLINGTON

APPLICATIONS

- For medium power linear and switching applications

PINNING

PIN	DESCRIPTION
1	Emitter
2	Collector;connected to mounting base
3	Base

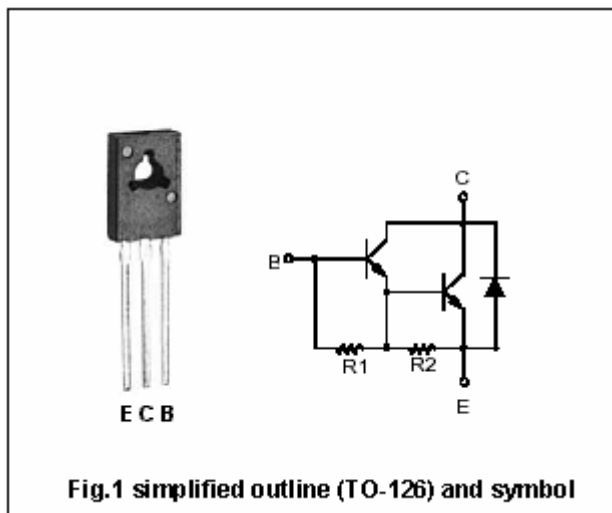

Fig.1 simplified outline (TO-126) and symbol

Absolute maximum ratings (Ta=25 )

SYMBOL	PARAMETER	CONDITIONS	VALUE	UNIT	
V <sub>CBO</sub>	Collector-base voltage	Open emitter	BD675A	45	V
			BD677A	60	
			BD679A	80	
			BD681	100	
V <sub>CEO</sub>	Collector-emitter voltage	Open base	BD675A	45	V
			BD677A	60	
			BD679A	80	
			BD681	100	
V <sub>EBO</sub>	Emitter -base voltage	Open collector	5	V	
I <sub>C</sub>	Collector current		4	A	
I <sub>CM</sub>	Collector current-Peak		6	A	
I <sub>B</sub>	Base current		0.1	A	
P <sub>C</sub>	Collector power dissipation	T <sub>C</sub> =25	40	W	
T <sub>j</sub>	Junction temperature		150		
T <sub>stg</sub>	Storage temperature		-65~150		

## Silicon NPN Power Transistors

## BD675A/677A/679A/681

## CHARACTERISTICS

T<sub>j</sub>=25 unless otherwise specified

SYMBOL	PARAMETER		CONDITIONS	MIN	TYP.	MAX	UNIT
V <sub>CEO(SUS)</sub>	Collector-emitter sustaining voltage	BD675A	I <sub>C</sub> =50mA; I <sub>B</sub> =0	45			V
		BD677A		60			
		BD679A		80			
		BD681		100			
V <sub>CEsat</sub>	Collector-emitter saturation voltage	BD675A/677A/679A	I <sub>C</sub> =2A; I <sub>B</sub> =40mA			2.8	V
		BD681	I <sub>C</sub> =1.5A; I <sub>B</sub> =30mA			2.5	
V <sub>BE(ON)</sub>	Base-emitter voltage	BD675A/677A/679A	I <sub>C</sub> =2A; V <sub>CE</sub> =3V			2.5	V
		BD681	I <sub>C</sub> =1.5A; V <sub>CE</sub> =3V			2.5	
I <sub>CBO</sub>	Collector cut-off current	BD675A	V <sub>CB</sub> =45V; I <sub>E</sub> =0			0.2	mA
		BD677A	V <sub>CB</sub> =60V; I <sub>E</sub> =0				
		BD679A	V <sub>CB</sub> =80V; I <sub>E</sub> =0				
		BD681	V <sub>CB</sub> =100V; I <sub>E</sub> =0				
I <sub>CEO</sub>	Collector cut-off current	BD675A	V <sub>CE</sub> =45V; V <sub>BE</sub> =0			0.5	mA
		BD677A	V <sub>CE</sub> =60V; V <sub>BE</sub> =0				
		BD679A	V <sub>CE</sub> =80V; V <sub>BE</sub> =0				
		BD681	V <sub>CE</sub> =100V; V <sub>BE</sub> =0				
I <sub>EBO</sub>	Emitter cut-off current		V <sub>EB</sub> =5V; I <sub>C</sub> =0			2	mA
h <sub>FE</sub>	DC current gain	BD675A/677A/679A	I <sub>C</sub> =2A; V <sub>CE</sub> =3V	750			
		BD681	I <sub>C</sub> =1.5A; V <sub>CE</sub> =3V	750			

PACKAGE OUTLINE

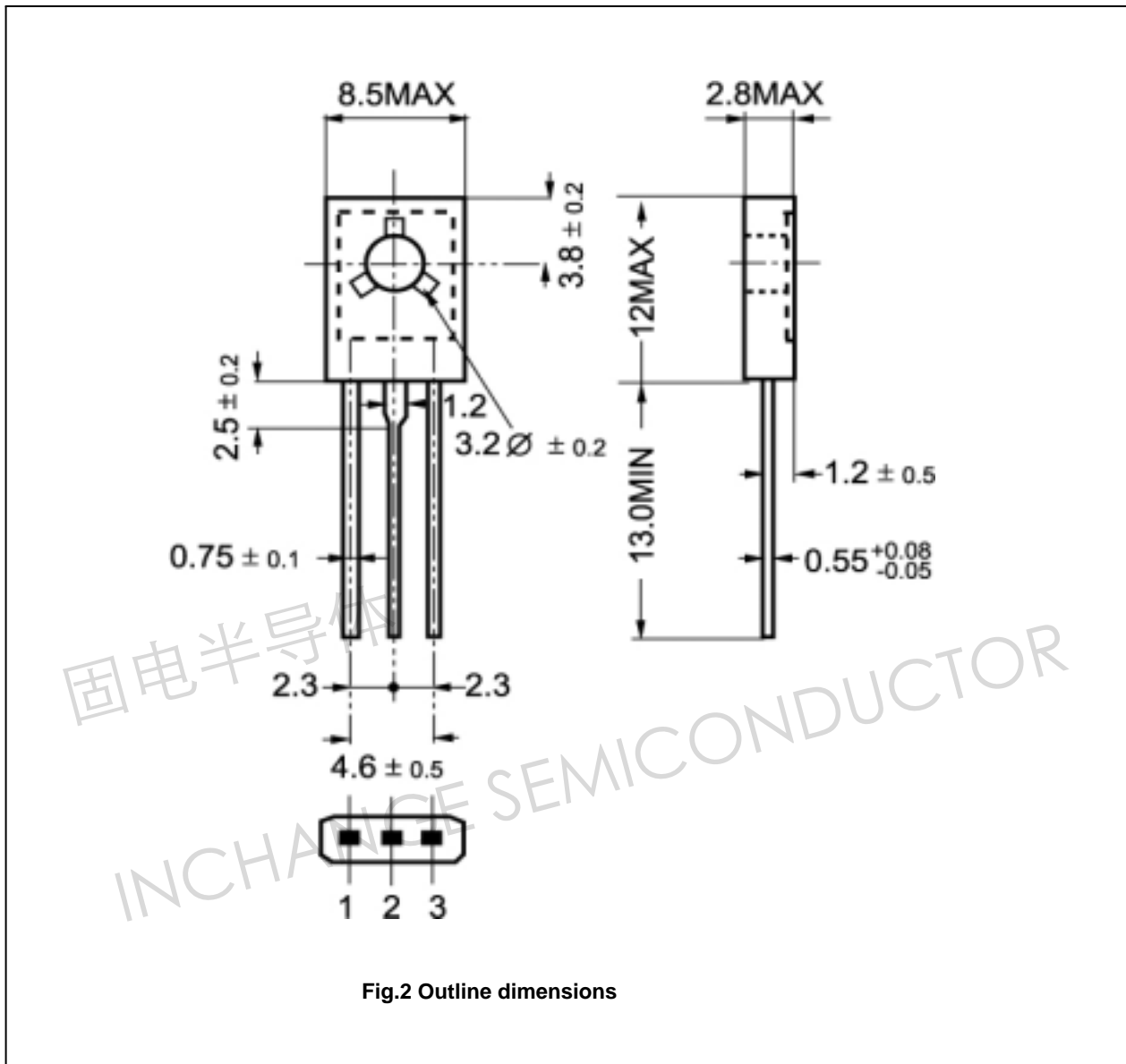

Fig.2 Outline dimensions