

CRYSTAL CONTROLLED OSCILLATORS

3.3V SURFACE MOUNT 5x3.2mm LVCMOS CLOCK OSCILLATOR



7143

ABSOLUTE MAXIMUM RATINGS

TABLE 1.0

PARAMETER	UNITS	MINIMUM	NOMINAL	MAXIMUM	UNITS	NOTE
Storage Temperature		-55	-	125	°C	
Supply Voltage	(Vcc)	-0.5	-	7.0	Vdc	

MODEL SPECIFICATIONS:

TABLE 2.0

MODEL 7143

PARAMETER	UNITS	MINIMUM	NOMINAL	MAXIMUM	UNITS	NOTE
Frequency Range	(Fo)	1.8	-	160	MHz	
Frequency Tolerance:		-20	-	20	ppm	1

OPERATING SPECIFICATIONS

TABLE 3.0

PARAMETER	UNITS	MINIMUM	NOMINAL	MAXIMUM	UNITS	NOTE
Operating Temperature Range		-20	-	70	°C	
Supply Voltage	(Vdd)	3.0	3.3	3.6	Vdc	
Supply Current	1.8 to 49.999 MHz	(Icc)	-	20	mA	
	50 to 79.999 MHz	(Icc)	-	30	mA	
	80 to 124.999 MHz	(Icc)	-	40	mA	
	125 to 160.0 MHz	(Icc)	-	50	mA	

INPUT CHARACTERISTICS

TABLE 4.0

PARAMETER	UNITS	MINIMUM	NOMINAL	MAXIMUM	UNITS	NOTE
Enable Voltage	(Vih)	70% Vdd	-	-	Vdc	2
Disable Voltage	(Vil)	-	-	30% Vdd	Vdc	
Enable Time		-	-	10	mS	
Disable Time		-	-	150	nS	
Output Disable Current	(Icc)	-	-	10	uA	

HCMOS OUTPUT CHARACTERISTICS

TABLE 5.0

PARAMETER	UNITS	MINIMUM	NOMINAL	MAXIMUM	UNITS	NOTE
LOAD		-	-	15	pF	
Voltage	(High)	(Voh)	2.70	-	Vdc	
	(Low)	(Vol)	-	0.36	Vdc	
Current	(High)	(Ioh)	-2	-	mA	
	(Low)	(Ioh)	-	2	mA	
Duty Cycle	1.5 to 49.999 MHz		45	50	55	%
	50 to 160 MHz		40	50	60	%
Rise / Fall Time	1.8 to 79.999 MHz		-	6	nS	3
	80 to 124.999 MHz		-	4	nS	3
	125 to 160 MHz		-	3	nS	3
Start-Up Time		-	-	10	mS	
Jitter		-	-	5	pS RMS	

PACKAGE CHARACTERISTICS

TABLE 6.0

Package	Hermetically sealed ceramic package and metal cover
---------	---

Note:

- 1) Inclusive of calibration @ 25°C, frequency vs. temperature stability, supply voltage change, load change, shock and vibration, 10 years aging.
- 2) Oscillator output is enabled with no connection on pad 1.
- 3) Duty Cycle measured at 50% of Vcc.
- 4) Rise and fall times measured from 10% to 90%.

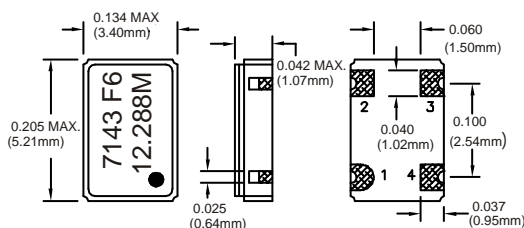

PAD	CONNECTION
1	ENABLE/DISABLE
2	GROUND
3	OUTPUT
4	Vcc

Dimensional Tolerance: ±.02" (.508mm)
±.005" (.127mm)

DESCRIPTION

Connor-Winfield model 7133 is a 3.3V HCMOS, Surface Mount, Fixed Frequency Crystal Oscillators (XO) designed for use in all applications requiring precision clocks. These oscillators feature low stand-by current (10uA) when output is disabled. The surface mount package is designed for high-density mounting and is optimum for mass production.

FEATURES

1.8 to 160 MHz

3.3V OPERATION

TRI-STATE ENABLE / DISABLE FUNCTION

OVERALL FREQUENCY TOLERANCE: ±20ppm

TEMPERATURE RANGE: -20 to 70°C

POWER SAVING FUNCTION: 10uA when disabled.

CERAMIC SURFACE MOUNT PACKAGE

TAPE AND REEL PACKAGING

RoHS COMPLIANT / LEAD FREE

ORDERING INFORMATION

7143 - 12.288 MHz

CLOCK
SERIES

CENTER
FREQUENCY

Specifications subject to change without notice.

CRYSTAL CONTROLLED OSCILLATORS

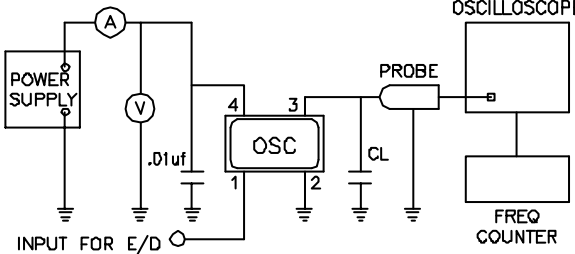
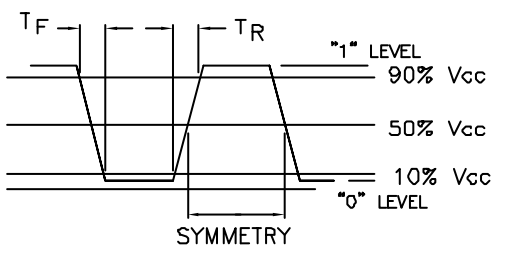
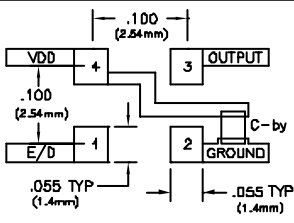
ENVIRONMENTAL CHARACTERISTICS	TEST CIRCUIT
<p>TEMPERATURE CYCLE: The specimen shall meet electrical characteristics after tested 5 cycles of -55°C/30 min & +125°C/30 min.</p> <p>HERMETICAL No bubbles appear in Flourinert (FC-43) at 125°C ±5°C, for 5 minutes.</p> <p>SOLVENT RESISTANCE: Marking will withstand immersion in Isopropyl Alcohol or Trichloroethylene.</p>	
<p>SOLDERING</p> <p>GENERAL CONDITIONS: 260°C max x 10 sec max x 2 times max or 230°C max x 180 sec max x 1 time.</p> <p>TYPICAL OPERATION DATA (Vapor phase reflow) 20 to 100 sec up to 215°C, 50 sec at 215°C then down to room temperature per 1 to 5°C/sec</p>	<p>OUTPUT WAVEFORM</p> 
<p>MECHANICAL CHARACTERISTICS</p> <p>FREE DROP: The specimen shall meet electrical characteristics after tested 3 times Free Drop testing on the hard wooden board from a height of 75cm.</p> <p>VIBRATION: The specimen shall meet electrical characteristics after tested by the following conditions: 10-55Hz 1.5mm Amplitude, 55-2000Hz 20G's, 2 hours for each plane.</p> <p>THERMAL SHOCK: After applied Thermal Shock of 260°C max x 10 sec max x 2 times, or 230°C max x 180 sec max, the specimen shall meet electrical characteristics.</p> <p>SOLDERABILITY: (EIAJ-RGX-0102/1D1 Condition 1a)</p> <ol style="list-style-type: none"> 1. Flux: MIL-F-14256 (WW Rosin=25%, Isopropyl alcohol=75%) 2. Solder: QQ-S-571 (Sn=63%, Pb=37%) 3. Solder bath temperature: 235°C ±5°C. 4. Depth of immersion: Up to electrical terminal. 5. Immersing time: Within 2 sec ±0.5 sec into solder bath. <p>After performing the above procedures, a newly soldered coverage shall be greater than 90%.</p>	<p>SUGGESTED PAD LAYOUT</p>  <p>Bypass capacitor, C-by, should be ceramic capacitor ≥ .01uF.</p>

TAPING AND REEL DIMENSIONS

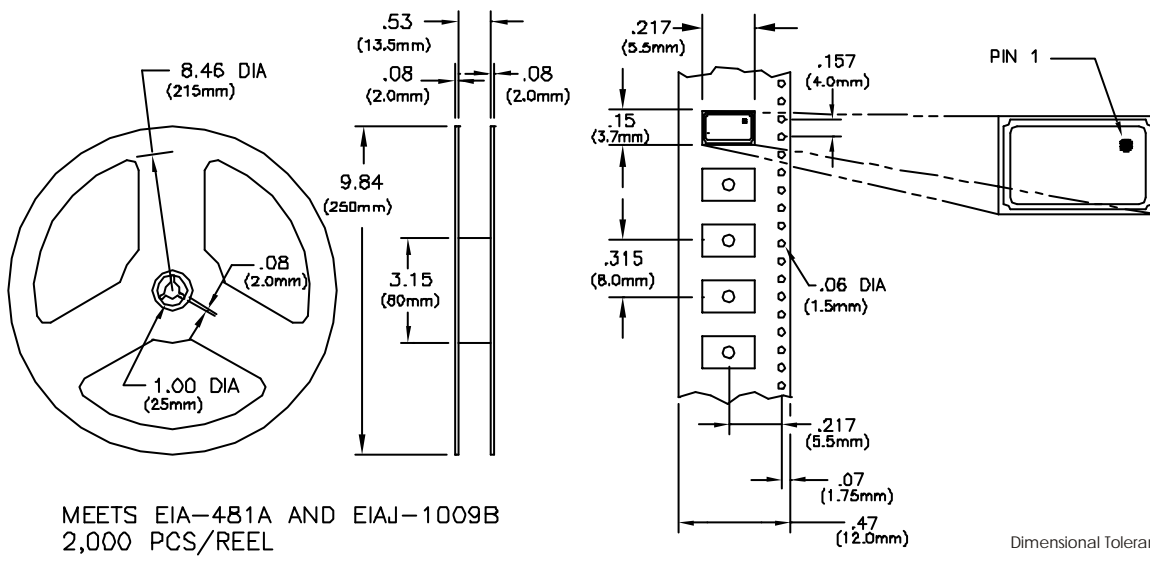

Specifications subject to change without notice.