

$V_{CE} = 1200\text{ V}$   
 $I_C = 150\text{ A}$

# IGBT-Die

## 5SMY 12M1200



Die size: 13.5 x 13.5 mm

Doc. No. 5SYA1639-01 Sep 06

- Ultra low loss thin IGBT die
- Highly rugged SPT<sup>+</sup> design
- Large bondable emitter area

### Maximum rated values <sup>1)</sup>

Parameter	Symbol	Conditions	min	max	Unit
Collector-emitter voltage	$V_{CES}$	$V_{GE} = 0\text{ V}$ , $T_{vj} \geq 25\text{ °C}$		1200	V
DC collector current	$I_C$			150	A
Peak collector current	$I_{CM}$	Limited by $T_{vjmax}$		300	A
Gate-emitter voltage	$V_{GES}$		-20	20	V
IGBT short circuit SOA	$t_{psc}$	$V_{CC} = 900\text{ V}$ , $V_{CEM} \leq 1200\text{ V}$ $V_{GE} \leq 15\text{ V}$ , $T_{vj} \leq 125\text{ °C}$		10	$\mu\text{s}$
Junction temperature	$T_{vj}$		-40	150	$^{\circ}\text{C}$

<sup>1)</sup> Maximum rated values indicate limits beyond which damage to the device may occur per IEC 60747 - 9

IGBT characteristic values <sup>2)</sup>

Parameter	Symbol	Conditions	min	typ	max	Unit
Collector (-emitter) breakdown voltage	$V_{(BR)CES}$	$V_{GE} = 0 \text{ V}$ , $I_C = 1 \text{ mA}$ , $T_{vj} = 25 \text{ °C}$	1200			V
Collector-emitter saturation voltage	$V_{CE \text{ sat}}$	$I_C = 150 \text{ A}$ , $V_{GE} = 15 \text{ V}$	$T_{vj} = 25 \text{ °C}$	1.9		V
			$T_{vj} = 125 \text{ °C}$	2.1		V
Collector cut-off current	$I_{CES}$	$V_{CE} = 1200 \text{ V}$ , $V_{GE} = 0 \text{ V}$	$T_{vj} = 25 \text{ °C}$		100	$\mu\text{A}$
			$T_{vj} = 125 \text{ °C}$	600		$\mu\text{A}$
Gate leakage current	$I_{GES}$	$V_{CE} = 0 \text{ V}$ , $V_{GE} = \pm 20 \text{ V}$ , $T_{vj} = 125 \text{ °C}$	-200		200	nA
Gate-emitter threshold voltage	$V_{GE(TO)}$	$I_C = 6 \text{ mA}$ , $V_{CE} = V_{GE}$ , $T_{vj} = 25 \text{ °C}$	5	6.2	7	V
Gate charge	$Q_{ge}$	$I_C = 150 \text{ A}$ , $V_{CE} = 600 \text{ V}$ , $V_{GE} = -15 \dots 15 \text{ V}$		1530		nC
Input capacitance	$C_{ies}$	$V_{CE} = 25 \text{ V}$ , $V_{GE} = 0 \text{ V}$ , $f = 1 \text{ MHz}$ , $T_{vj} = 25 \text{ °C}$		10.6		nF
Output capacitance	$C_{oes}$			0.71		
Reverse transfer capacitance	$C_{res}$			0.47		
Internal gate resistance	$R_{Gint}$			2		$\Omega$
Turn-on delay time	$t_{d(on)}$	$V_{CC} = 600 \text{ V}$ , $I_C = 150 \text{ A}$ , $R_G = 6.8 \text{ }\Omega$ , $V_{GE} = \pm 15 \text{ V}$ ,	$T_{vj} = 25 \text{ °C}$	190		ns
			$T_{vj} = 125 \text{ °C}$	220		
Rise time	$t_r$	$L_\sigma = 60 \text{ nH}$ , inductive load	$T_{vj} = 25 \text{ °C}$	60		ns
			$T_{vj} = 125 \text{ °C}$	60		
Turn-off delay time	$t_{d(off)}$	$V_{CC} = 600 \text{ V}$ , $I_C = 150 \text{ A}$ , $R_G = 6.8 \text{ }\Omega$ , $V_{GE} = \pm 15 \text{ V}$ ,	$T_{vj} = 25 \text{ °C}$	460		ns
			$T_{vj} = 125 \text{ °C}$	530		
Fall time	$t_f$	$L_\sigma = 60 \text{ nH}$ , inductive load	$T_{vj} = 25 \text{ °C}$	55		ns
			$T_{vj} = 125 \text{ °C}$	75		
Turn-on switching energy	$E_{on}$	$V_{CC} = 600 \text{ V}$ , $I_C = 150 \text{ A}$ , $V_{GE} = \pm 15 \text{ V}$ , $R_G = 6.8 \text{ }\Omega$ , $L_\sigma = 60 \text{ nH}$ , inductive load, FWD: 2x 5SLX 12F1200	$T_{vj} = 25 \text{ °C}$	11.2		mJ
			$T_{vj} = 125 \text{ °C}$	16.7		
Turn-off switching energy	$E_{off}$	$V_{CC} = 600 \text{ V}$ , $I_C = 150 \text{ A}$ , $V_{GE} = \pm 15 \text{ V}$ , $R_G = 6.8 \text{ }\Omega$ , $L_\sigma = 60 \text{ nH}$ , inductive load	$T_{vj} = 25 \text{ °C}$	9.8		mJ
			$T_{vj} = 125 \text{ °C}$	15.3		
Short circuit current	$I_{SC}$	$t_{psc} \leq 10 \text{ }\mu\text{s}$ , $V_{GE} = 15 \text{ V}$ , $T_{vj} = 125 \text{ °C}$ , $V_{CC} = 900 \text{ V}$ , $V_{CEM} \leq 1200 \text{ V}$		650		A

<sup>2)</sup> Characteristic values according to IEC 60747 - 9

## Mechanical properties

Parameter				Unit
Dimensions	Overall die	L x W	13.5 x 13.5	mm
	exposed front metal	L x W (except gate pad)	12.0 x 12.0	mm
	gate pad	L x W	1.47 x 1.47	mm
	thickness		130 ± 20	µm
Metallization <sup>3)</sup>	front (E)	AlSi1	4	µm
	back (C)	Al / Ti / Ni / Ag	1.2	µm

<sup>3)</sup> For assembly instructions refer to : IGBT and Diode chips from ABB Switzerland Ltd, Semiconductors, Doc. No. 5SYA 2033.

## Outline drawing

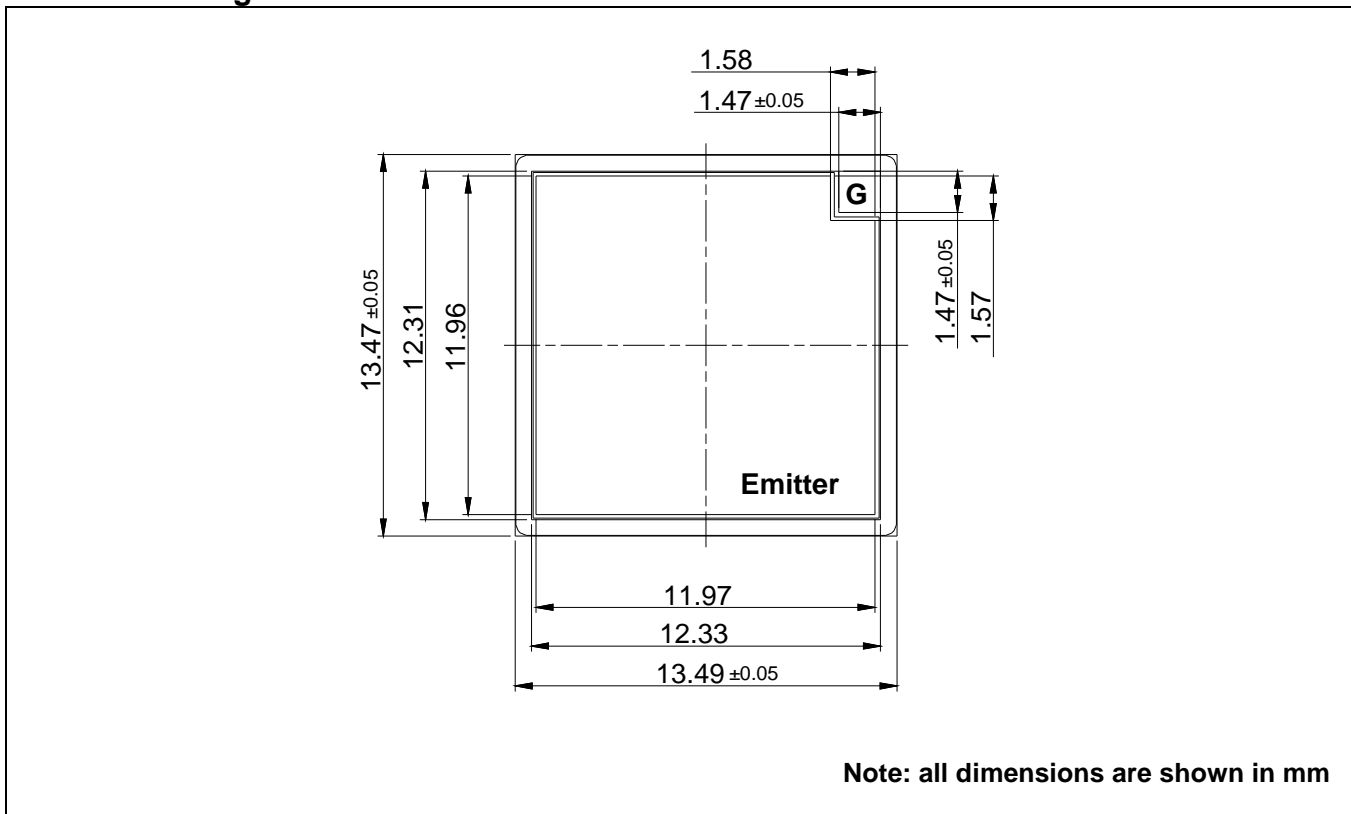

This is an electrostatic sensitive device, please observe the international standard IEC 60747-1, Chap. IX.

This product has been designed and qualified for Industrial Level.

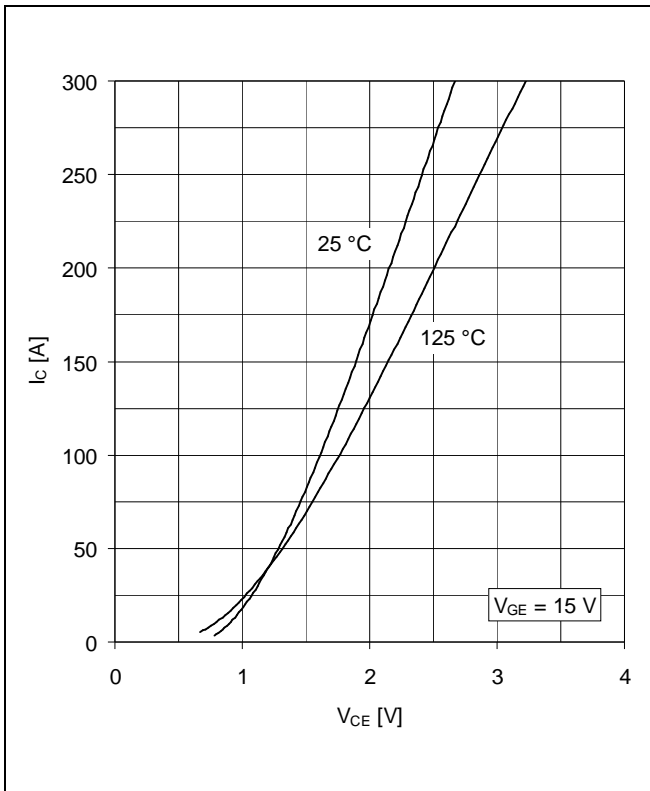

**Fig. 1** Typical on-state characteristics

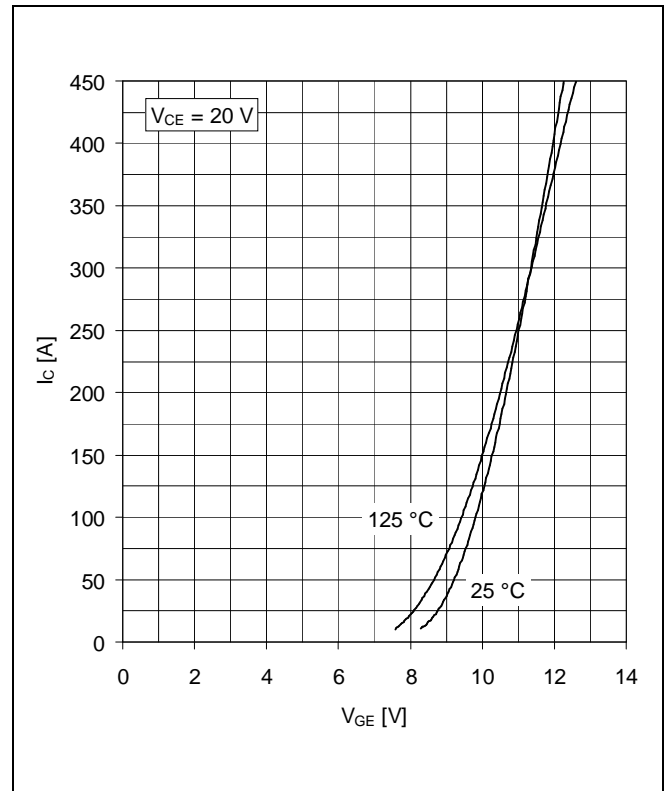

**Fig. 2** Typical transfer characteristics

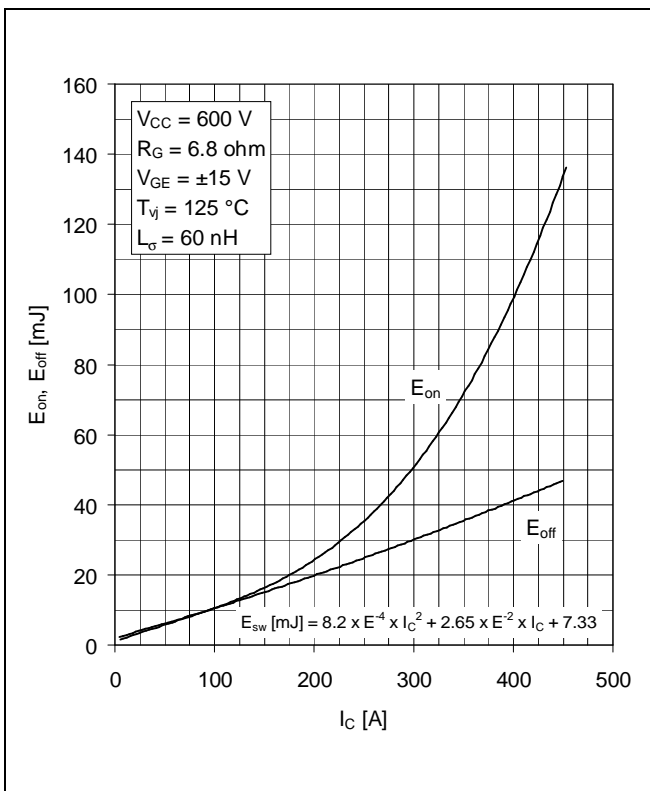

**Fig. 3** Typical switching characteristics vs collector current

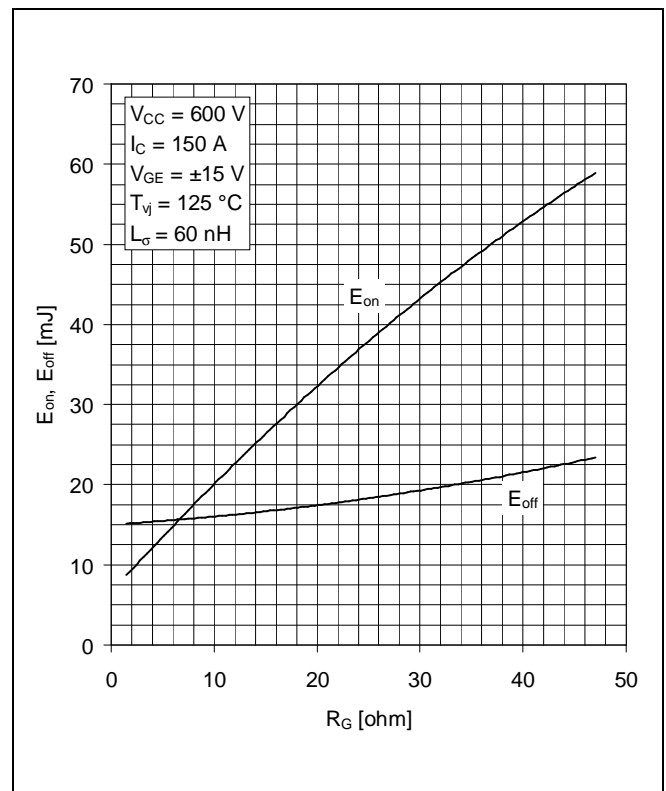

**Fig. 4** Typical switching characteristics vs gate resistor

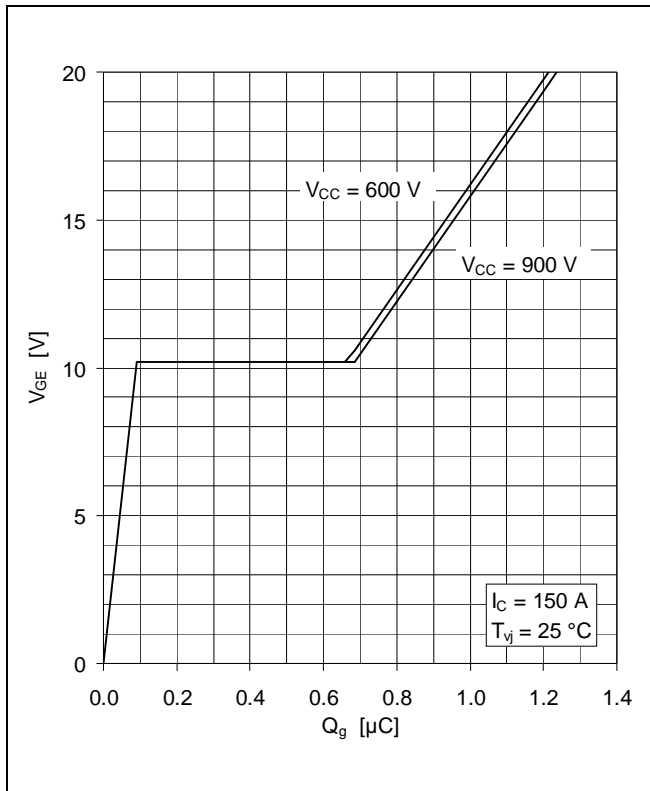

**Fig. 5** Typical gate charge characteristics

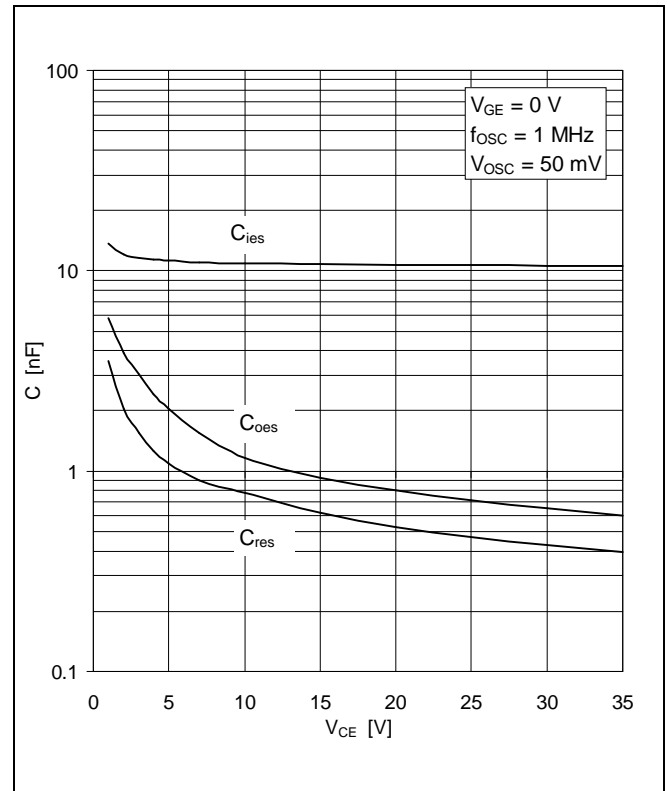

**Fig. 6** Typical capacitances vs collector-emitter voltage

ABB Switzerland Ltd, Semiconductors reserves the right to change specifications without notice.



**ABB Switzerland Ltd**  
**Semiconductors**  
 Fabrikstrasse 3  
 CH-5600 Lenzburg, Switzerland

Telephone +41 (0)58 586 1419  
 Fax +41 (0)58 586 1306  
 Email [abbsem@ch.abb.com](mailto:abbsem@ch.abb.com)  
 Internet [www.abb.com/semiconductors](http://www.abb.com/semiconductors)