

Next Generation FTG for Intel[®] Architecture

Features

- Supports Intel Pentium[®] 4-Type CPUs
- Selectable CPU Frequencies
- Two Differential CPU Clock Pairs
- Four 100 MHz Differential SRC Clock Pairs
- One CPU/SRC Selectable Differential Clock Pair
- One 96 MHz Differential Dot Clock Support
- Two 48 MHz Clocks
- Four 33 MHz PCI Clocks

- Two 33 MHz PCI Free Running Clocks
- Low Voltage Frequency Select Input
- I²C Support Byte/Word/Block Read/Write Capabilities
- Ideal Lexmark Spread Spectrum Profile for Maximum EMI Reduction
- 3.3V Power Supply
- 48-pin SSOP Package

| CPU | SRC | PCI | DOT | USB | REF |
|---------|---------|-----|-----|-----|-----|
| x2 / x3 | x4 / x5 | x 6 | x 1 | x 2 | x 2 |

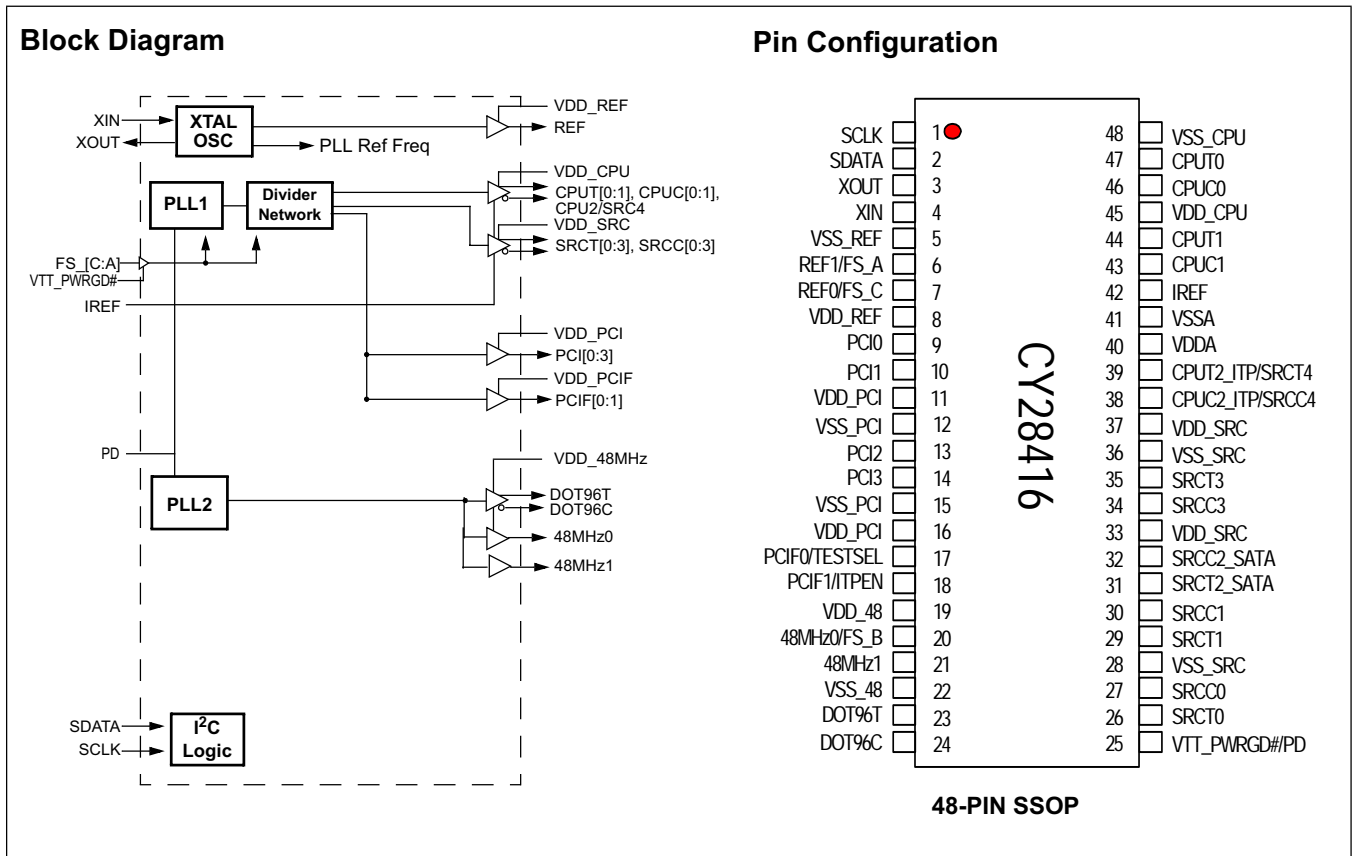

Pin Definition

| Pin No. | Name | Type | Description |
|-----------------------|------------------------------------|----------------|--|
| 47,46,44,43 | CPUT/C[0:1] | O, DIF | Differential CPU clock output. |
| 39,38 | CPUT2_ITP/SRCT4 CPUC2_ITP/SRCC4 | O, DIF | Selectable Differential CPU or SRC clock output. ITP_EN = 0 @VTT_PWRGD# assertion PIN 39,38 = SRCT4,SRCC4 ITP_EN = 1 @VTT_PWRGD# assertion PIN 39,38 = CPUT2_ITP,CPUC2_ITP |
| 23,24 | DOT96T, DOT96C | O, DIF | Differential 96 MHz clock output. |
| 6 | FS_A/REF1 | I/O, SE | 3.3V tolerant input for CPU frequency/REF clock <i>Refer to DC Electrical Specifications table for V_{il_FS} and V_{ih_FS} specifications.</i> |
| 20 | FS_B/48 MHz0 | I/O, SE | 3.3V tolerant input for CPU frequency/48 MHz clock <i>Refer to DC Electrical Specifications table for V_{il_FS} and V_{ih_FS} specifications.</i> |
| 7 | FS_C/REF0 | I/O, SE | 3.3V tolerant input for CPU frequency/REF clock <i>Refer to DC Electrical Specifications table for V_{il_FS} and V_{ih_FS} specifications.</i> |
| 42 | IREF | I | A precision resistor is attached to this pin, which is connected to the internal current reference. |
| 18 | ITP_EN/PCIF1 | I/O, SE | Enable SRC4 or CPU2_ITP/PCIF clock. (sampled on the VTT_PWRGD# assertion). 0 = SRC4, 1 = CPU2_ITP |
| 9,10,13,14 | PCI | O, SE | 33 MHz clock output. |
| 21 | 48 MHz1 | O, SE | 48 MHz clock output. (Uses same control SMBus register as 48 MHz0 to control enable/disable.) |
| 1 | SCLK | I | SMBus compatible SCLOCK. |
| 2 | SDATA | I/O | SMBus compatible SDATA. |
| 26,27,29,30, 34,35 | SRCT/C[0:3] | O, DIF | Differential Serial reference clock. |
| 31,32 | SRCT2_SATA, SRCC2_SATA | O, DIF | Differential Serial reference clock. Recommended output for SATA |
| 17 | TEST_SEL/PCIF0 | I/O, SE, PD | LVTTTL input for selecting HI-Z or Normal operation/33 MHz Clock 0 = Normal operation, 1 = HI-Z when VTT_PWRGD# is sampled |
| 19 | VDD_48 | PWR | 3.3V power supply for outputs |
| 45 | VDD_CPU | PWR | 3.3V power supply for outputs |
| 11, 16 | VDD_PCI | PWR | 3.3V power supply for outputs |
| 8 | VDD_REF | PWR | 3.3V power supply for outputs |
| 33, 37 | VDD_SRC | PWR | 3.3V power supply for outputs |
| 40 | VDDA | PWR | 3.3V power supply for PLL |
| 22 | VSS_48 | GND | Ground for outputs |
| 48 | VSS_CPU | GND | Ground for outputs |
| 12, 15 | VSS_PCI | GND | Ground for outputs |
| 5 | VSS_REF | GND | Ground for outputs |
| 28, 36 | VSS_SRC | GND | Ground for outputs |
| 41 | VSSA | GND | Ground for PLL |
| 25 | VTT_PWRGD#/PD | I, PD | 3.3V LVTTTL Input. This pin is a level-sensitive strobe used to latch the FS_A, FS_B, FS_C/TEST_SEL, and PCIF0/ITP_EN Inputs. After asserting VTT_PWRGD# (active LOW), this pin becomes a realtime input for asserting power-down (active HIGH) |
| 4 | XIN | I | 14.318 MHz Crystal Input |
| 3 | XOUT | O | 14.318 MHz Crystal Output |

Frequency Select Pins (FS_A, FS_B, and FS_C)

Host clock frequency selection is achieved by applying the appropriate logic levels to FS_A, FS_B, FS_C inputs prior to VTT_PWRGD# assertion (as seen by the clock synthesizer). Upon VTT_PWRGD# being sampled LOW by the clock chip (indicating processor VTT voltage is stable), the clock chip samples the FS_A, FS_B, and FS_C input values. For all logic levels of FS_A, FS_B, and FS_C VTT_PWRGD# employs a one-shot functionality in that once a valid LOW on VTT_PWRGD# has been sampled, all further VTT_PWRGD#, FS_A, FS_B, and FS_C transitions will be ignored, except in test mode.

Serial Data Interface

To enhance the flexibility and function of the clock synthesizer, a two-signal serial interface is provided. Through the Serial Data Interface, various device functions, such as individual clock output buffers, can be individually enabled or disabled. The registers associated with the Serial Data Interface

initialize to their default setting upon power-up, and therefore use of this interface is optional. Clock device register changes are normally made upon system initialization, if any are required. The interface cannot be used during system operation for power management functions.

Data Protocol

The clock driver serial protocol accepts byte write, byte read, block write, and block read operations from the controller. For block write/read operation, the bytes must be accessed in sequential order from lowest to highest byte (most significant bit first) with the ability to stop after any complete byte has been transferred. For byte write and byte read operations, the system controller can access individually indexed bytes. The offset of the indexed byte is encoded in the command code, as described in *Table 2*.

The block write and block read protocol is outlined in *Table 3* while *Table 4* outlines the corresponding byte write and byte read protocol. The slave receiver address is 11010010 (D2h).

Table 1. Frequency Select Table (FS_A FS_B)

| FS_C | FS_B | FS_A | CPU | SRC | PCIF/PCI | REF0 | DOT96 | USB |
|------|------|------|----------|---------|----------|------------|--------|--------|
| 1 | 0 | 1 | 100 MHz | 100 MHz | 33 MHz | 14.318 MHz | 96 MHz | 48 MHz |
| 0 | 0 | 1 | 133 MHz | 100 MHz | 33 MHz | 14.318 MHz | 96 MHz | 48 MHz |
| 0 | 1 | 1 | 166 MHz | 100 MHz | 33 MHz | 14.318 MHz | 96 MHz | 48 MHz |
| 0 | 1 | 0 | 200 MHz | 100 MHz | 33 MHz | 14.318 MHz | 96 MHz | 48 MHz |
| 0 | 0 | 0 | 266 MHz | 100 MHz | 33 MHz | 14.318 MHz | 96 MHz | 48 MHz |
| 1 | 0 | 0 | RESERVED | | | | | |
| 1 | 1 | 0 | | | | | | |
| 1 | 1 | 1 | | | | | | |

Table 2. Command Code Definition

| Bit | Description |
|-------|---|
| 7 | 0 = Block read or block write operation, 1 = Byte read or byte write operation |
| (6:0) | Byte offset for byte read or byte write operation. For block read or block write operations, these bits should be '0000000' |

Table 3. Block Read and Block Write Protocol

| Block Write Protocol | | Block Read Protocol | |
|----------------------|--|---------------------|--------------------------------|
| Bit | Description | Bit | Description |
| 1 | Start | 1 | Start |
| 8:2 | Slave address – 7 bits | 8:2 | Slave address – 7 bits |
| 9 | Write | 9 | Write |
| 10 | Acknowledge from slave | 10 | Acknowledge from slave |
| 18:11 | Command Code – 8 Bits | 18:11 | Command Code – 8 Bits |
| 19 | Acknowledge from slave | 19 | Acknowledge from slave |
| 27:20 | Byte Count – 8 bits (Skip this step if I ² C_EN bit set) | 20 | Repeat start |
| 28 | Acknowledge from slave | 27:21 | Slave address – 7 bits |
| 36:29 | Data byte 1 – 8 bits | 28 | Read = 1 |
| 37 | Acknowledge from slave | 29 | Acknowledge from slave |
| 45:38 | Data byte 2 – 8 bits | 37:30 | Byte Count from slave – 8 bits |

Table 3. Block Read and Block Write Protocol (continued)

| Block Write Protocol | | Block Read Protocol | |
|----------------------|-------------------------------|---------------------|-------------------------------------|
| Bit | Description | Bit | Description |
| 46 | Acknowledge from slave | 38 | Acknowledge |
| | Data Byte /Slave Acknowledges | 46:39 | Data byte 1 from slave – 8 bits |
| | Data Byte N –8 bits | 47 | Acknowledge |
| | Acknowledge from slave | 55:48 | Data byte 2 from slave – 8 bits |
| | Stop | 56 | Acknowledge |
| | | | Data bytes from slave / Acknowledge |
| | | | Data Byte N from slave – 8 bits |
| | | | NOT Acknowledge |
| | | ... | Stop |

Table 4. Byte Read and Byte Write Protocol

| Byte Write Protocol | | Byte Read Protocol | |
|---------------------|------------------------|--------------------|--------------------------|
| Bit | Description | Bit | Description |
| 1 | Start | 1 | Start |
| 8:2 | Slave address – 7 bits | 8:2 | Slave address – 7 bits |
| 9 | Write | 9 | Write |
| 10 | Acknowledge from slave | 10 | Acknowledge from slave |
| 18:11 | Command Code – 8 bits | 18:11 | Command Code – 8 bits |
| 19 | Acknowledge from slave | 19 | Acknowledge from slave |
| 27:20 | Data byte – 8 bits | 20 | Repeated start |
| 28 | Acknowledge from slave | 27:21 | Slave address – 7 bits |
| 29 | Stop | 28 | Read |
| | | 29 | Acknowledge from slave |
| | | 37:30 | Data from slave – 8 bits |
| | | 38 | NOT Acknowledge |
| | | 39 | Stop |

Control Registers

Byte 0: Control Register 0

| Bit | @Pup | Name | Description |
|-----|------|------------------------------------|---|
| 7 | 1 | CPUT2_ITP/SRCT4 CPUC2_ITP/SRCC4 | CPU[T/C]2_ITP/SRC[T/C]4 Output Enable 0 = Disable (Hi-Z), 1 = Enable |
| 6 | 1 | RESERVED | RESERVED, Set = 1 |
| 5 | 1 | RESERVED | RESERVED, Set = 1 |
| 4 | 1 | SRC[T/C]3 | SRC[T/C]3 Output Enable 0 = Disable (Hi-Z), 1 = Enable |
| 3 | 1 | SRC[T/C]2_SATA | SRC[T/C]2_SATA Output Enable 0 = Disable (Hi-Z), 1 = Enable |
| 2 | 1 | SRC[T/C]1 | SRC[T/C]1 Output Enable 0 = Disable (Hi-Z), 1 = Enable |
| 1 | 1 | SRC[T/C]0 | SRC[T/C]0 Output Enable 0 = Disable (Hi-Z), 1 = Enable |
| 0 | 1 | RESERVED | RESERVED, Set = 1 |

Byte 1: Control Register 1

| Bit | @Pup | Name | Description |
|-----|------|---------------------------------|---|
| 7 | 1 | Spread Selection | 0=Center Spread, 1= Down Spread (Default) |
| 6 | 1 | DOT_96T/C | DOT_96 MHz Output Enable 0 = Disable (Hi-Z), 1 = Enabled |
| 5 | 1 | 48 MHz0, 48 MHz1 | 48-MHz Output Enable 0 = Disabled, 1 = Enabled |
| 4 | 1 | REF0 | REF Output Enable 0 = Disabled, 1 = Enabled |
| 3 | 1 | REF1 | REF Output Enable 0 = Disabled, 1 = Enabled |
| 2 | 1 | CPU[T/C]1 | CPU[T/C]1 Output Enable 0 = Disable (Hi-Z), 1 = Enabled |
| 1 | 1 | CPU[T/C]0 | CPU[T/C]0 Output Enable 0 = Disable (Hi-Z), 1 = Enabled |
| 0 | 0 | CPUT/C SRCT/C PCIF PCI | Spread Spectrum Enable 0 = Spread off, 1 = Spread on |

Byte 2: Control Register 2

| Bit | @Pup | Name | Description |
|-----|------|----------|--|
| 7 | 1 | PCI3 | PCI3 Output Enable 0 = Disabled, 1 = Enabled |
| 6 | 1 | PCI2 | PCI2 Output Enable 0 = Disabled, 1 = Enabled |
| 5 | 1 | RESERVED | RESERVED, Set = 1 |
| 4 | 1 | RESERVED | RESERVED, Set = 1 |
| 3 | 1 | PCI1 | PCI1 Output Enable 0 = Disabled, 1 = Enabled |
| 2 | 1 | PCI0 | PCI0 Output Enable 0 = Disabled, 1 = Enabled |
| 1 | 1 | PCIF1 | PCIF2 Output Enable 0 = Disabled, 1 = Enabled |
| 0 | 1 | PCIF0 | PCIF1 Output Enable 0 = Disabled, 1 = Enabled |

Byte 3: Control Register 3

| Bit | @Pup | Name | Description |
|-----|------|-----------|---|
| 7 | 0 | SRC[T/C]4 | Allow control of SRC[T/C]4 with assertion of SW PCI_STP# 0 = Free running, 1 = Stopped with PCI_STP# |
| 6 | 0 | RESERVED | RESERVED, Set = 0 |
| 5 | 0 | RESERVED | RESERVED, Set = 0 |
| 4 | 0 | SRC[T/C]3 | Allow control of SRC[T/C]3 with assertion of SW PCI_STP# 0 = Free running, 1 = Stopped with PCI_STP# |
| 3 | 0 | SRC2_SATA | Allow control of SRC2_SATA with assertion of SW PCI_STP# 0 = Free running, 1 = Stopped with PCI_STP# |
| 2 | 0 | SRC[T/C]1 | Allow control of SRC[T/C]1 with assertion of SW PCI_STP# 0 = Free running, 1 = Stopped with PCI_STP# |
| 1 | 0 | SRC[T/C]0 | Allow control of SRC[T/C]0 with assertion of SW PCI_STP# 0 = Free running, 1 = Stopped with PCI_STP# |
| 0 | 0 | RESERVED | RESERVED, Set = 0 |

Byte 4: Control Register 4

| Bit | @Pup | Name | Description |
|-----|------|------------|---|
| 7 | 0 | RESERVED | RESERVED, Set = 0 |
| 6 | 0 | DOT96[T/C] | DOT_PWRDWN Drive Mode 0 = Driven in PWRDWN, 1 = Tri-state |
| 5 | 0 | PCIF1 | Allow control of PCIF2 with assertion of SW PCI_STP# 0 = Free running, 1 = Stopped with PCI_STP# |
| 4 | 0 | PCIF0 | Allow control of PCIF1 with assertion of SW PCI_STP# 0 = Free running, 1 = Stopped with PCI_STP# |
| 3 | 0 | RESERVED | RESERVED, Set = 0 |
| 2 | 1 | RESERVED | RESERVED, Set = 1 |
| 1 | 1 | RESERVED | RESERVED, Set = 1 |
| 0 | 1 | RESERVED | RESERVED, Set = 1 |

Byte 5: Control Register 5

| Bit | @Pup | Name | Description |
|-----|------|---------------|---|
| 7 | 0 | SRC[T/C][4:0] | SRC[T/C] Stop Drive Mode 0 = Driven when SW PCI_STP# asserted, 1 = Tri-state when SW PCI_STP# asserted |
| 6 | 0 | RESERVED | RESERVED, Set = 0 |
| 5 | 0 | RESERVED | RESERVED, Set = 0 |
| 4 | 0 | RESERVED | RESERVED, Set = 0 |
| 3 | 0 | SRC[T/C][4:0] | SRC[T/C] PWRDWN Drive Mode 0 = Driven when PD asserted, 1 = Tri-state when PD asserted |
| 2 | 0 | CPU[T/C]2_ITP | CPU[T/C]2_ITP PWRDWN Drive Mode 0 = Driven when PD asserted, 1 = Tri-state when PD asserted |
| 1 | 0 | CPU[T/C]1 | CPU[T/C]1 PWRDWN Drive Mode 0 = Driven when PD asserted, 1 = Tri-state when PD asserted |
| 0 | 0 | CPU[T/C]0 | CPU[T/C]0 PWRDWN Drive Mode 0 = Driven when PD asserted, 1 = Tri-state when PD asserted |

Byte 6: Control Register 6

| Bit | @Pup | Name | Description |
|-----|---------------------|----------------|---|
| 7 | 0 | RESERVED | RESERVED, Set = 0 |
| 6 | 0 | | Test Clock Mode Entry Control 0 = Normal operation, 1 = Hi-Z mode |
| 5 | 1 | REF1 | REF1 Output Drive Strength 0 = Low, 1 = High |
| 4 | 1 | REF0 | REF0 Output Drive Strength 0 = Low, 1 = High |
| 3 | 1 | PCIF, SRC, PCI | SW PCI_STP# Function 0=SW PCI_STP assert, 1= SW PCI_STP deassert When this bit is set to 0, all STOPPABLE PCI, PCIF, and SRC outputs will be stopped in a synchronous manner with no short pulses. When this bit is set to 1, all STOPPED PCI, PCIF, and SRC outputs will resume in a synchronous manner with no short pulses. |
| 2 | Externally selected | | FS_C. Reflects the value of the FS_C pin sampled on power-up 0 = FS_C was low during VTT_PWRGD# assertion |
| 1 | Externally selected | | FS_B. Reflects the value of the FS_B pin sampled on power-up 0 = FS_B was low during VTT_PWRGD# assertion |
| 0 | Externally selected | | FS_A. Reflects the value of the FS_A pin sampled on power-up 0 = FS_A was low during VTT_PWRGD# assertion |

Byte 7: Vendor ID

| Bit | @Pup | Name | Description |
|-----|------|---------------------|---------------------|
| 7 | 0 | Revision Code Bit 3 | Revision Code Bit 3 |
| 6 | 0 | Revision Code Bit 2 | Revision Code Bit 2 |
| 5 | 0 | Revision Code Bit 1 | Revision Code Bit 1 |
| 4 | 1 | Revision Code Bit 0 | Revision Code Bit 0 |
| 3 | 1 | Vendor ID Bit 3 | Vendor ID Bit 3 |
| 2 | 0 | Vendor ID Bit 2 | Vendor ID Bit 2 |
| 1 | 0 | Vendor ID Bit 1 | Vendor ID Bit 1 |
| 0 | 0 | Vendor ID Bit 0 | Vendor ID Bit 0 |

Table 5. Crystal Recommendations

| Frequency (Fund) | Cut | Loading | Load Cap | Drive (max.) | Shunt Cap (max.) | Motional (max.) | Tolerance (max.) | Stability (max.) | Aging (max.) |
|------------------|-----|----------|----------|--------------|------------------|-----------------|------------------|------------------|--------------|
| 14.31818 MHz | AT | Parallel | 20 pF | 0.1 mW | 5 pF | 0.016 pF | 50 ppm | 50 ppm | 5 ppm |

Crystal Recommendations

The CY28416 requires a **Parallel Resonance Crystal**. Substituting a series resonance crystal will cause the CY28416 to operate at the wrong frequency and violate the ppm specification. For most applications there is a 300-ppm frequency shift between series and parallel crystals due to incorrect loading.

Crystal Loading

Crystal loading plays a critical role in achieving low ppm performance. To realize low ppm performance, the total capacitance the crystal will see must be considered to calculate the appropriate capacitive loading (CL).

Figure 1 shows a typical crystal configuration using the two trim capacitors. An important clarification for the following discussion is that the trim capacitors are in series with the crystal, not parallel. It's a common misconception that load capacitors are in parallel with the crystal and should be approximately equal to the load capacitance of the crystal. This is **not true**.

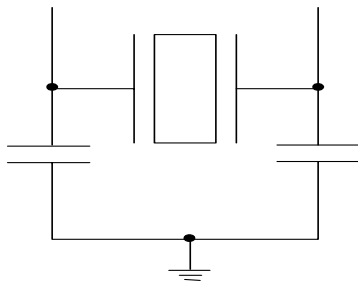
Figure 1. Crystal Capacitive Clarification
Calculating Load Capacitors

In addition to the standard external trim capacitors, trace capacitance and pin capacitance must also be considered to correctly calculate crystal loading. As mentioned previously, the capacitance on each side of the crystal is in series with the crystal. This means the total capacitance on each side of the crystal must be twice the specified crystal load capacitance

(CL). While the capacitance on each side of the crystal is in series with the crystal, trim capacitors (Ce1,Ce2) should be calculated to provide equal capacitive loading on both sides.

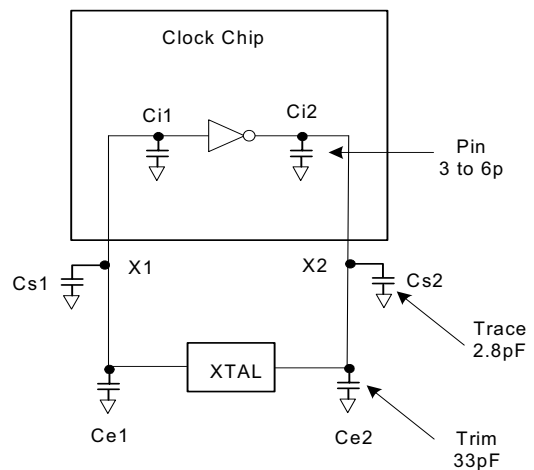
Figure 2. Crystal Loading Example

Use the following formulas to calculate the trim capacitor values for Ce1 and Ce2.

Load Capacitance (each side)

$$C_e = 2 * CL - (C_s + C_i)$$

Total Capacitance (as seen by the crystal)

$$CL_e = \frac{1}{\left(\frac{1}{C_{e1} + C_{s1} + C_{i1}} + \frac{1}{C_{e2} + C_{s2} + C_{i2}} \right)}$$

- CL.....Crystal load capacitance
- CLe..... Actual loading seen by crystal using standard value trim capacitors
- Ce..... External trim capacitors
- Cs..... Stray capacitance (terraced)
- Ci Internal capacitance (lead frame, bond wires etc.)

PD (Power-down) Clarification

The VTT_PWRGD# /PD pin is a dual-function pin. During initial power-up, the pin functions as VTT_PWRGD#. Once VTT_PWRGD# has been sampled LOW by the clock chip, the pin assumes PD functionality. The PD pin is an asynchronous active HIGH input used to shut off all clocks cleanly prior to shutting off power to the device. This signal needs to be synchronized internal to the device prior to powering down the clock synthesizer. PD is also an asynchronous input for powering up the system. When PD is asserted HIGH, all clocks need to be driven to a LOW value and held prior to turning off the VCOs and the crystal oscillator.

PD (Power-down) Assertion

When PD is sampled HIGH by two consecutive rising edges of CPUC, all single-ended outputs must be held LOW on their next HIGH-to-LOW transition and differential clocks must held high or tri-stated (depending on the state of the control register drive mode bit) on the next diff clock# HIGH-to-LOW transition. When the SMBus PD drive mode bit corresponding to the differential (CPU, SRC, and DOT) clock output of interest is programmed to '0', the clock output must be held with "Diff clock" pin driven high at 2 x Iref, and "Diff clock#" tri-state. If the control register PD drive mode bit corresponding to the

output of interest is programmed to "1", then both the "Diff clock" and the "Diff clock#" are tri-state. Note the example in *Figure 3* shows CPU = 133 MHz and PD drive mode = '1' for all differential outputs. This diagram and description is applicable to valid CPU frequencies 100, 133, 166, 200, 266, 333, and 400 MHz. In the event that PD mode is desired as the initial power-on state, PD must be asserted high in less than 10 μ s after asserting VTT_PWRGD#.

PD Deassertion

The power-up latency needs to be less than 1.8 ms. This is the time from the deassertion of the PD pin or the ramping of the power supply until the time that stable clocks are output from the clock chip. All differential outputs stopped in a tri-state condition resulting from power down must be driven high in less than 300 μ s of PD deassertion to a voltage greater than 200 mV. After the clock chip's internal PLL is powered up and locked, all outputs are to be enabled within a few clock cycles of each other. *Figure 4* is an example showing the relationship of clocks coming up. Unfortunately, we can not show all possible combinations, designers need to insure that from the first active clock output to the last takes no more than two full PCI clock cycles.

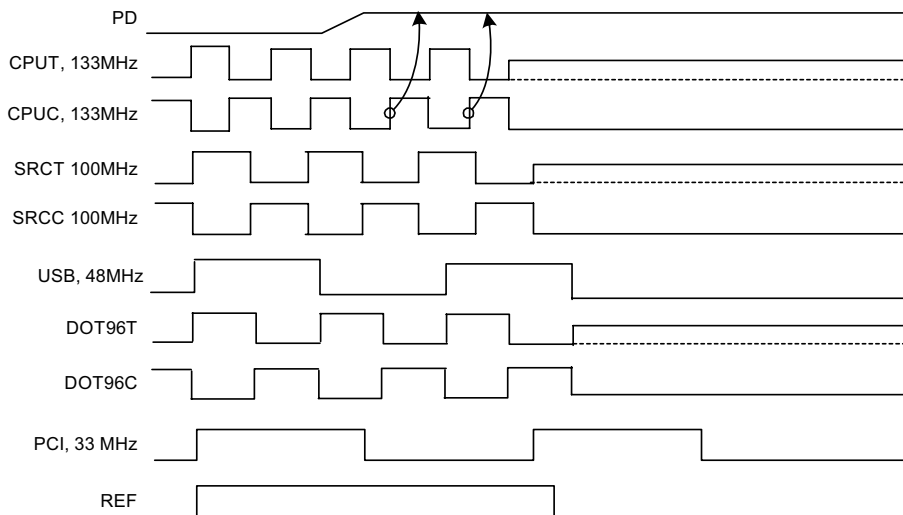
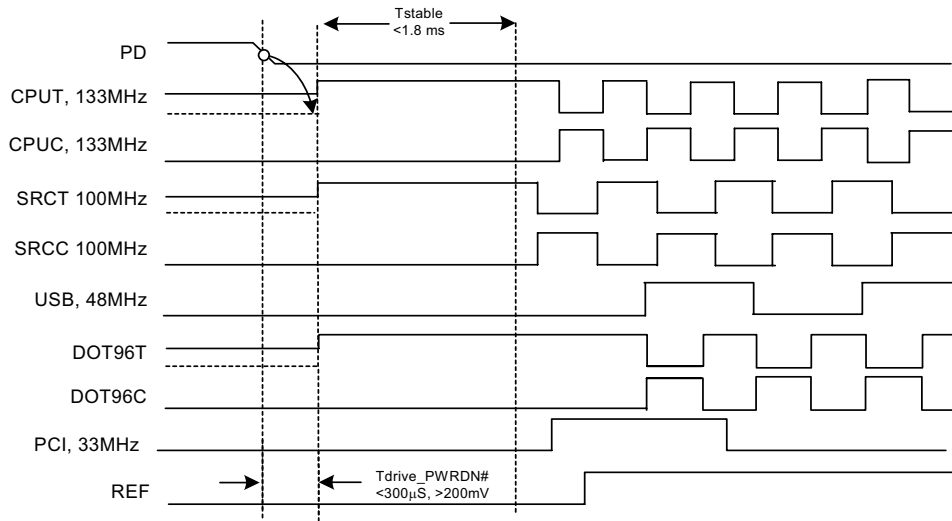
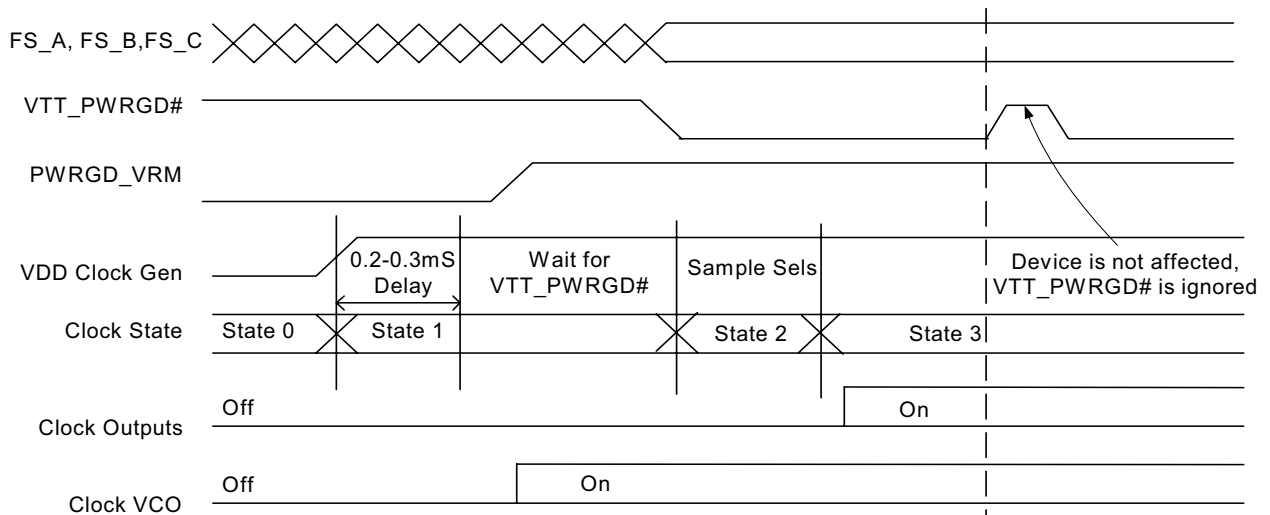
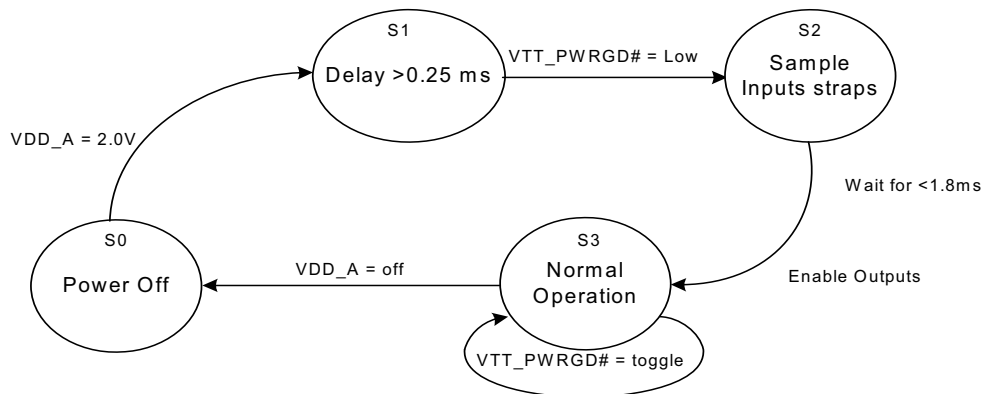

Figure 3. Power-down Assertion Timing Waveform

Figure 4. Power-down Deassertion Timing Waveform

Figure 5. VTT_PWRGD# Timing Diagram

Figure 6. Clock Generator Power-up/Run State Diagram

Absolute Maximum Conditions

| Parameter | Description | Condition | Min. | Max. | Unit |
|--------------------|-----------------------------------|-----------------------------|------|-----------------------|------|
| V _{DD} | Core Supply Voltage | | -0.5 | 4.6 | V |
| V _{DD_A} | Analog Supply Voltage | | -0.5 | 4.6 | V |
| V _{IN} | Input Voltage | Relative to V _{SS} | -0.5 | V _{DD} + 0.5 | VDC |
| T _S | Temperature, Storage | Non-functional | -65 | 150 | °C |
| T _A | Temperature, Operating Ambient | Functional | 0 | 70 | °C |
| T _J | Temperature, Junction | Functional | - | 150 | °C |
| ∅ _{JC} | Dissipation, Junction to Case | Mil-Spec 883E Method 1012.1 | - | 15 | °C/W |
| ∅ _{JA} | Dissipation, Junction to Ambient | JEDEC (JESD 51) | - | 45 | °C/W |
| ESD _{HBM} | ESD Protection (Human Body Model) | MIL-STD-883, Method 3015 | 2000 | - | V |
| UL-94 | Flammability Rating | At 1/8 in. | V-0 | | |
| MSL | Moisture Sensitivity Level | | 1 | | |

Multiple Supplies: The Voltage on any input or I/O pin cannot exceed the power pin during power-up. Power supply sequencing is NOT required.

DC Electrical Specifications

| Parameter | Description | Condition | Min. | Max. | Unit |
|--|-------------------------------|--|-----------------------|-----------------------|------|
| V _{DD_A} , V _{DD_REF} , V _{DD_PCI} , V _{DD_3V66} , V _{DD_48} , V _{DD_CPU} | 3.3V Operating Voltage | 3.3 ± 5% | 3.135 | 3.465 | V |
| V _{IL12C} | Input Low Voltage | SDATA, SCLK | - | 1.0 | V |
| V _{IH12C} | Input High Voltage | SDATA, SCLK | 2.2 | - | V |
| V _{IL_FS} | FS_[A:C] Input Low Voltage | | 0.7 | V _{DD} + 0.5 | V |
| V _{IH_FS} | FS_[A:C] Input High Voltage | | V _{SS} - 0.3 | 0.35 | V |
| V _{IL} | Input Low Voltage | | V _{SS} - 0.5 | 0.8 | V |
| V _{IH} | Input High Voltage | | 2.0 | V _{DD} + 0.5 | V |
| I _{IL} | Input Low Leakage Current | Except internal pull-up resistors, 0 < V _{IN} < V _{DD} | -5 | - | μA |
| I _{IH} | Input High Leakage Current | Except internal pull-down resistors, 0 < V _{IN} < V _{DD} | - | 5 | μA |
| V _{OL} | Output Low Voltage | I _{OL} = 1 mA | - | 0.4 | V |
| V _{OH} | Output High Voltage | I _{OH} = -1 mA | 2.4 | - | V |
| I _{OZ} | High-impedance Output Current | | -10 | 10 | μA |
| C _{IN} | Input Pin Capacitance | | 2 | 5 | pF |
| C _{OUT} | Output Pin Capacitance | | 3 | 6 | pF |
| L _{IN} | Pin Inductance | | - | 7 | nH |
| V _{XIH} | Xin High Voltage | | 0.7V _{DD} | V _{DD} | V |
| V _{XIL} | Xin Low Voltage | | 0 | 0.3V _{DD} | V |
| I _{DD3.3V} | Dynamic Supply Current | At max load and freq per <i>Table 6</i> and <i>Figure 7</i> | - | 400 | mA |
| I _{PD3.3V} | Power-down Supply Current | PD asserted, Outputs driven | - | 70 | mA |
| I _{PD3.3V} | Power-down Supply Current | PD asserted, Outputs Tri-stated | - | 2 | mA |

AC Electrical Specifications

| Parameter | Description | Condition | Min. | Max. | Unit |
|---------------------------------|--------------------------------------|---|--------|-------------------------|------|
| Crystal | | | | | |
| T _{DC} | XIN Duty Cycle | The device will operate reliably with input duty cycles up to 30/70 but the REF clock duty cycle will not be within specification | 47.5 | 52.5 | % |
| T _{PERIOD} | XIN Period | When XIN is driven from an external clock source | 69.841 | 71.0 | ns |
| T _R / T _F | XIN Rise and Fall Times | Measured between 0.3V _{DD} and 0.7V _{DD} | – | 10.0 | ns |
| T _{CCJ} | XIN Cycle to Cycle Jitter | As an average over 1- μ s duration | – | 500 | ps |
| L _{ACC} | Long-term Accuracy | Over 150 ms | – | 300 | ppm |
| CPU at 0.7V | | | | | |
| T _{DC} | CPUT and CPUC Duty Cycle | Measured at crossing point V _{OX} | 40 | 60 | % |
| T _{PERIOD} | 100-MHz CPUT and CPUC Period | Measured at crossing point V _{OX} | 9.9970 | 10.003 | ns |
| T _{PERIOD} | 133-MHz CPUT and CPUC Period | Measured at crossing point V _{OX} | 7.4978 | 7.5023 | ns |
| T _{PERIOD} | 166-MHz CPUT and CPUC Period | Measured at crossing point V _{OX} | 5.9982 | 6.0018 | ns |
| T _{PERIOD} | 200-MHz CPUT and CPUC Period | Measured at crossing point V _{OX} | 4.9985 | 5.0015 | ns |
| T _{PERIOD} | 266-MHz CPUT and CPUC Period | Measured at crossing point V _{OX} | 3.7489 | 3.7511 | ns |
| T _{PERIODSS} | 100-MHz CPUT and CPUC Period, SSC | Measured at crossing point V _{OX} | 9.9970 | 10.0533 | ns |
| T _{PERIODSS} | 133-MHz CPUT and CPUC Period, SSC | Measured at crossing point V _{OX} | 7.4978 | 7.5400 | ns |
| T _{PERIODSS} | 166-MHz CPUT and CPUC Period, SSC | Measured at crossing point V _{OX} | 5.9982 | 6.0320 | ns |
| T _{PERIODSS} | 200-MHz CPUT and CPUC Period, SSC | Measured at crossing point V _{OX} | 4.9985 | 5.0266 | ns |
| T _{PERIODSS} | 266-MHz CPUT and CPUC Period, SSC | Measured at crossing point V _{OX} | 3.7489 | 3.7700 | ns |
| T _{SKEW} | Any CPUT/C to CPUT/C Clock Skew, SSC | Measured at crossing point V _{OX} | – | 160 | ps |
| T _{CCJ} | CPUT/C Cycle to Cycle Jitter | Measured at crossing point V _{OX} | – | 90 | ps |
| T _{CCJ} | CPU2/SRC4 Cycle to Cycle Jitter | Measured at crossing point V _{OX} | – | 150 | ps |
| T _R / T _F | CPUT and CPUC Rise and Fall Times | Measured from V _{OL} = 0.175 to V _{OH} = 0.525V | 175 | 700 | ps |
| T _{RFM} | Rise/Fall Matching | Determined as a fraction of 2*(T _R – T _F)/(T _R + T _F) | – | 20 | % |
| Δ T _R | Rise Time Variation | | – | 125 | ps |
| Δ T _F | Fall Time Variation | | – | 125 | ps |
| V _{HIGH} | Voltage High | Math averages <i>Figure 7</i> | 660 | 850 | mv |
| V _{LOW} | Voltage Low | Math averages <i>Figure 7</i> | –150 | – | mv |
| V _{OX} | Crossing Point Voltage at 0.7V Swing | | 250 | 550 | mv |
| V _{OVS} | Maximum Overshoot Voltage | | – | V _{HIGH} + 0.3 | V |
| V _{UDS} | Minimum Undershoot Voltage | | –0.3 | – | V |
| V _{RB} | Ring Back Voltage | See <i>Figure 7</i> . Measure SE | – | 0.2 | V |
| SRC | | | | | |
| T _{DC} | SRCT and SRCC Duty Cycle | Measured at crossing point V _{OX} | 45 | 55 | % |
| T _{PERIOD} | 100-MHz SRCT and SRCC Period | Measured at crossing point V _{OX} | 9.9970 | 10.003 | ns |
| T _{PERIODSS} | 100-MHz SRCT and SRCC Period, SSC | Measured at crossing point V _{OX} | 9.9970 | 10.0533 | ns |
| T _{SKEW} | Any SRCT/C to SRCT/C Clock Skew | Measured at crossing point V _{OX} | – | 130 | ps |
| T _{CCJ} | SRCT/C Cycle to Cycle Jitter | Measured at crossing point V _{OX} | – | 125 | ps |
| L _{ACC} | SRCT/C Long Term Accuracy | Measured at crossing point V _{OX} | – | 300 | ppm |
| T _R / T _F | SRCT and SRCC Rise and Fall Times | Measured from V _{OL} = 0.175 to V _{OH} = 0.525V | 175 | 700 | ps |
| T _{RFM} | Rise/Fall Matching | Determined as a fraction of 2*(T _R – T _F)/(T _R + T _F) | – | 20 | % |

AC Electrical Specifications (continued)

| Parameter | Description | Condition | Min. | Max. | Unit |
|-----------------|---------------------------------------|---|---------|------------------|------|
| ΔT_R | Rise Time Variation | | – | 125 | ps |
| ΔT_F | Fall Time Variation | | – | 125 | ps |
| V_{HIGH} | Voltage High | Math averages <i>Figure 7</i> | 660 | 850 | mv |
| V_{LOW} | Voltage Low | Math averages <i>Figure 7</i> | –150 | – | mv |
| V_{OX} | Crossing Point Voltage at 0.7V Swing | | 220 | 550 | mV |
| V_{OVS} | Maximum Overshoot Voltage | | – | $V_{HIGH} + 0.3$ | V |
| V_{UDS} | Minimum Undershoot Voltage | | –0.3 | – | V |
| V_{RB} | Ring Back Voltage | See <i>Figure 7</i> . Measure SE | – | 0.2 | V |
| PCI/PCIF | | | | | |
| T_{DC} | PCI Duty Cycle | Measurement at 1.5V | 45 | 55 | % |
| T_{PERIOD} | Spread Disabled PCIF/PCI Period | Measurement at 1.5V | 29.9910 | 30.0090 | ns |
| T_{PERIOD} | Spread Enabled PCIF/PCI Period | Measurement at 1.5V | 29.9910 | 30.1598 | ns |
| T_{HIGH} | PCIF and PCI high time | Measurement at 2.4V | 12.0 | – | ns |
| T_{LOW} | PCIF and PCI low time | Measurement at 0.4V | 12.0 | – | ns |
| T_R / T_F | PCIF and PCI rise and fall times | Measured between 0.4V and 2.4V | 0.3 | 1.2 | ns |
| T_{SKEW} | Any PCI clock to Any PCI clock Skew | Measurement at 1.5V | – | 500 | ps |
| T_{CCJ} | PCIF and PCI Cycle to Cycle Jitter | Measurement at 1.5V | – | 500 | ps |
| DOT | | | | | |
| T_{DC} | DOT96T and DOT96C Duty Cycle | Measured at crossing point V_{OX} | 45 | 55 | % |
| T_{PERIOD} | DOT96T and DOT96C Period | Measured at crossing point V_{OX} | 10.4135 | 10.4198 | ns |
| T_{CCJ} | DOT96T/C Cycle to Cycle Jitter | Measured at crossing point V_{OX} | – | 250 | ps |
| L_{ACC} | DOT96T/C Long Term Accuracy | Measured at crossing point V_{OX} | – | 300 | ppm |
| T_R / T_F | DOT96T and DOT96C Rise and Fall Times | Measured from $V_{OL} = 0.175$ to $V_{OH} = 0.525V$ | 175 | 780 | ps |
| T_{RFM} | Rise/Fall Matching | Determined as a fraction of $2*(T_R - T_F)/(T_R + T_F)$ | – | 20 | % |
| ΔT_R | Rise Time Variation | | – | 125 | ps |
| ΔT_F | Fall Time Variation | | – | 125 | ps |
| V_{HIGH} | Voltage High | Math averages <i>Figure 7</i> | 660 | 850 | mv |
| V_{LOW} | Voltage Low | Math averages <i>Figure 7</i> | –150 | – | mv |
| V_{OX} | Crossing Point Voltage at 0.7V Swing | | 200 | 550 | mV |
| V_{OVS} | Maximum Overshoot Voltage | | – | $V_{HIGH} + 0.3$ | V |
| V_{UDS} | Minimum Undershoot Voltage | | –0.3 | – | V |
| V_{RB} | Ring Back Voltage | See <i>Figure 7</i> . Measure SE | – | 0.2 | V |
| USB | | | | | |
| T_{DC} | Duty Cycle | Measurement at 1.5V | 45 | 55 | % |
| T_{PERIOD} | Period | Measurement at 1.5V | 20.8271 | 20.8396 | ns |
| T_{HIGH} | USB high time | Measurement at 2.4V | 8.090 | 10.200 | ns |
| T_{LOW} | USB low time | Measurement at 0.4V | 7.690 | 9.950 | ns |
| T_R / T_F | Rise and Fall Times | Measured between 0.4V and 2.4V | 0.4 | 1.4 | ns |
| T_{CCJ} | Cycle to Cycle Jitter | Measurement at 1.5V | – | 400 | ps |
| REF | | | | | |
| T_{DC} | REF Duty Cycle | Measurement at 1.5V | 45 | 55 | % |
| T_{PERIOD} | REF Period | Measurement at 1.5V | 69.8203 | 69.8622 | ns |

AC Electrical Specifications (continued)

| Parameter | Description | Condition | Min. | Max. | Unit |
|---------------------------------|-----------------------------------|--------------------------------|------|------|------|
| T_R / T_F | REF Rise and Fall Times | Measured between 0.4V and 2.4V | 0.2 | 2.1 | ns |
| T_{CCJ} | REF Cycle to Cycle Jitter | Measurement at 1.5V | – | 1000 | ps |
| ENABLE/DISABLE and SETUP | | | | | |
| T_{STABLE} | Clock Stabilization from Power-up | | – | 1.8 | ms |
| T_{SS} | Stopclock Set-up Time | | 10.0 | – | ns |
| T_{SH} | Stopclock Hold Time | | 0 | – | ns |

Table 6. Maximum Lumped Capacitive Output Loads

| Clock | Max Load | Unit |
|------------|----------|------|
| PCI Clocks | 30 | pF |
| 48M Clock | 20 | pF |
| REF Clock | 30 | pF |

Test and Measurement Set-up
For Differential CPU and SRC Output Signals

The following diagram shows lumped test load configurations for the differential Host Clock Outputs.

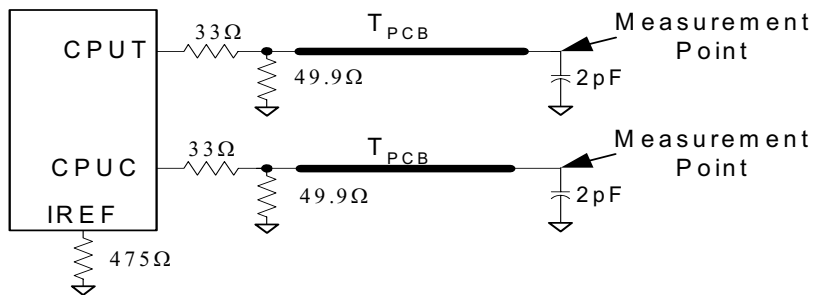
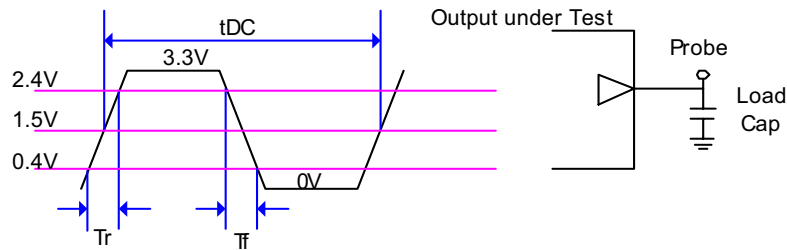
Figure 7. 0.7V Load Configuration

Figure 8. Lumped Load For Single-ended Output Signals (for AC Parameters Measurement)

Ordering Information

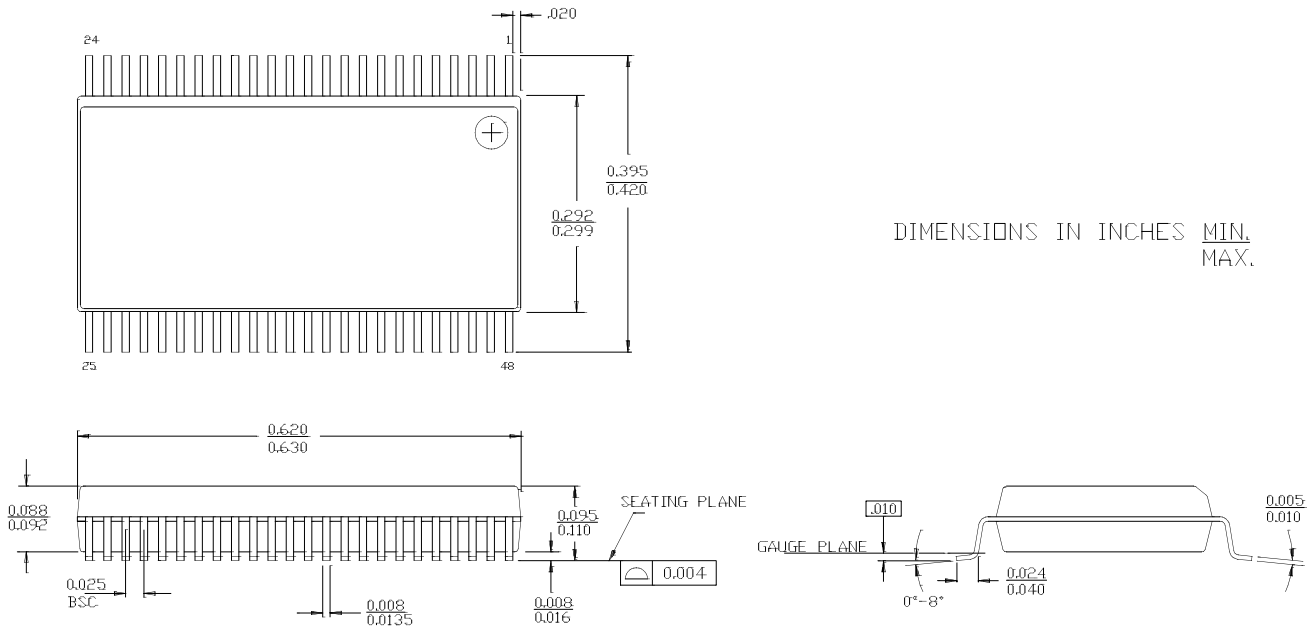
| Part Number | Package Type | Product Flow |
|------------------|---------------------------|------------------------|
| Lead-free | | |
| CY28416OXC | 48-pin SSOP | Commercial, 0° to 70°C |
| CY28416OXCT | 48-pin SSOP—Tape and Reel | Commercial, 0° to 70°C |

Package Drawings and Dimensions
48-lead Shrunken Small Outline Package O48

While SLI has reviewed all information herein for accuracy and reliability, Spectra Linear Inc. assumes no responsibility for the use of any circuitry or for the infringement of any patents or other rights of third parties which would result from each use. This product is intended for use in normal commercial applications and is not warranted nor is it intended for use in life support, critical medical instruments, or any other application requiring extended temperature range, high reliability, or any other extraordinary environmental requirements unless pursuant to additional processing by Spectra Linear Inc., and expressed written agreement by Spectra Linear Inc. Spectra Linear Inc. reserves the right to change any circuitry or specification without notice.