



### ■ Features :

- Battery controller for DIN Rail UPS system
- Parallel connection to DC BUS
- Suitable for 24V system up to 40A
- Installed on DIN Rail TS35 / 7.5 or 15
- Built-in battery test function
- Battery polarity protection
- Relay contact signal output and LED indicator for DC BUS OK, Battery OK, and Battery Discharge
- Cooling by free air convection
- 3 years warranty



### SPECIFICATION

MODEL	PS-UPS40	
DC INPUT / DC BUS	DC VOLTAGE	24 ~ 29V
	RATED CURRENT	40A
BATTERY INPUT / OUTPUT	VOLTAGE RANGE	21 ~ 29V
	CURRENT RANGE	0 ~ 40A
	CHARGE CURRENT (Typ.)	2A
	EXTERNAL BATTERY (Typ.)	4 / 7 / 12AH / 24V
FUNCTION	RELAY CONTACT RATING (max.)	30VDC, 1A
	DC BUS OK	Relay contact : Short when DC voltage between 21~29V(±3%), relay contacts ; Green LED on front panel LED(Green) : DC BUS OK : light, DC BUS fail : dark
	BATTERY FAIL <small>Note.2</small>	Relay contact : Short when battery failure is observed through the battery test function, relay contacts ; Red LED on front panel LED(Green) : DC BUS OK : light, DC BUS fail : dark
	BATTERY DISCHARGE	Relay contact : Short when battery in discharge condition, relay contacts ; Yellow LED on front panel LED(Green) : DC BUS OK : light, DC BUS fail : dark
ENVIRONMENT	WORKING TEMP.	-20 ~ +70°C
	WORKING HUMIDITY	20 ~ 90% RH
	STORAGE TEMP., HUMIDITY	-20 ~ +85°C, 10 ~ 95% RH
	VIBRATION	Component : 10 ~ 500Hz, 2G 10min./1cycle, 60min. each X, Y, Z axes ; Mounting : Compliance to IEC600068-2-6
SAFETY & EMC	WITHSTAND VOLTAGE	Terminal-Chassis :0.5KVAC, Relay Contacts-Terminal :0.5KVAC
	ISOLATION RESISTANCE	Terminal-Chassis :>100M Ohms/500VDC 25°C 70%RH
	EMI CONDUCTION & RADIATION	Compliance to EN55022 (CISPR22) Class B
OTHERS	EMS IMMUNITY	Compliance to EN61000-4-2,3,4,5,6,8, ENV50204, Heavy industry level, criteria A
	MTBF	161.9Khrs min. MIL-HDBK-217F (25°C)
	DIMENSION	55.5*125.2*100mm (W*H*D)
	PACKING	0.55Kg; 20pcs/12Kg/1.1CUFT
NOTE	1. All parameters NOT specially mentioned are measured at rated load and 25°C of ambient temperature. 2. Every 25 seconds, send out test signal through "Battery Fail" relay contact and LED indicator once the battery is fail.	

### Mechanical Specification

All dimensions shown in millimeters.  
To convert to inches multiply by 0.03937

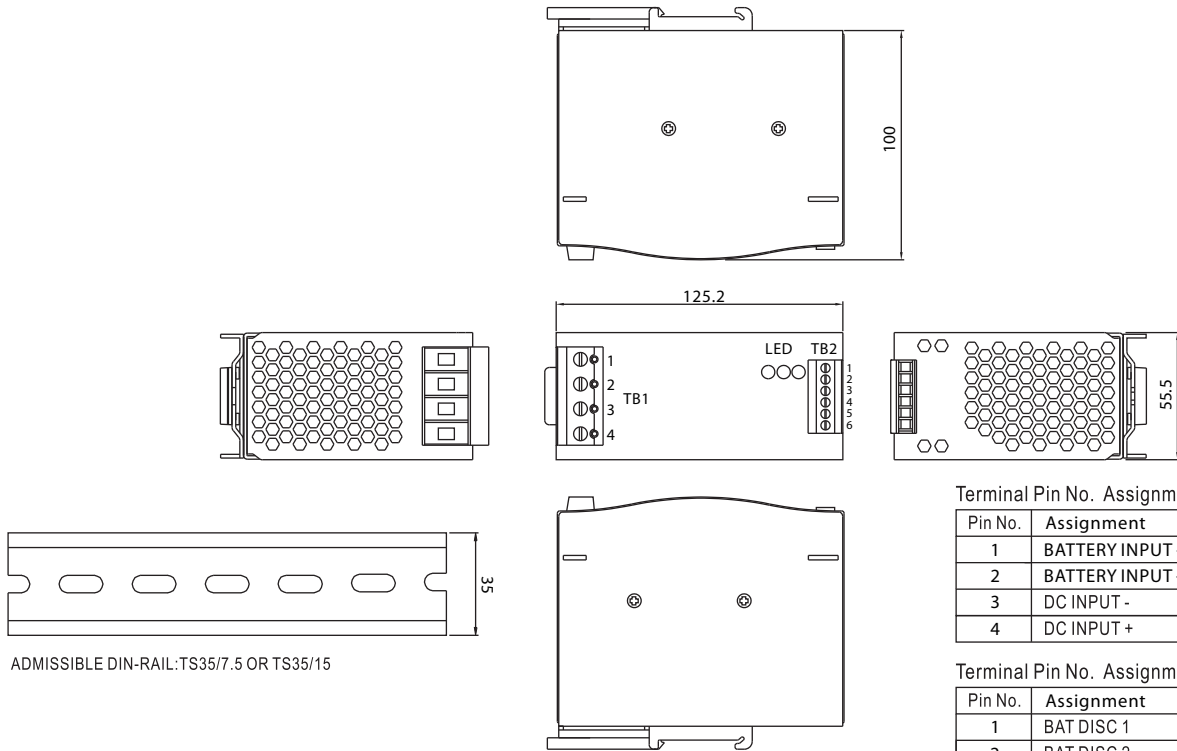

ADMISSIBLE DIN-RAIL: TS35/7.5 OR TS35/15

Terminal Pin No. Assignment (TB1)

Pin No.	Assignment
1	BATTERY INPUT +
2	BATTERY INPUT -
3	DC INPUT -
4	DC INPUT +

Terminal Pin No. Assignment (TB2)

Pin No.	Assignment
1	BAT DISC 1
2	BAT DISC 2
3	BAT OK 1
4	BAT OK 2
5	DC OK 1
6	DC OK 2

### Block Diagram

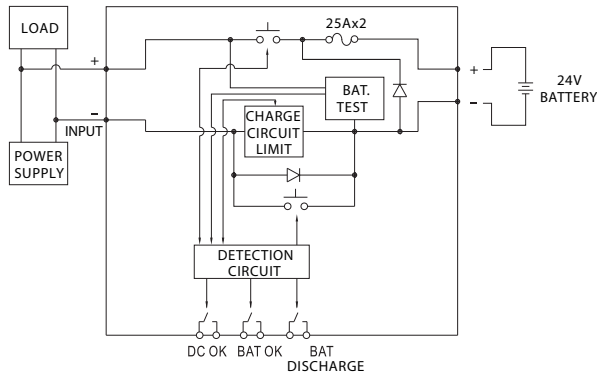

### Derating Curve

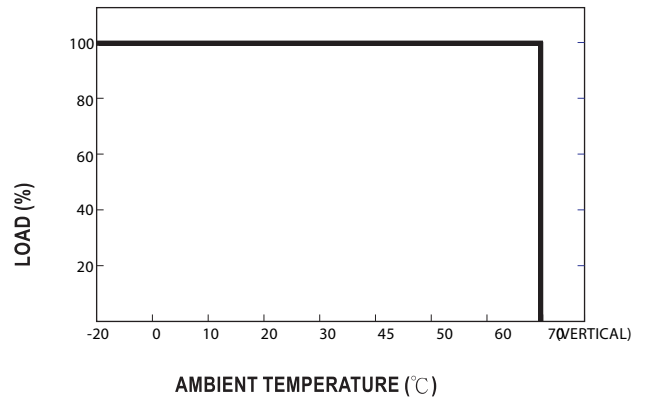

1. Back up connection for AC interruption

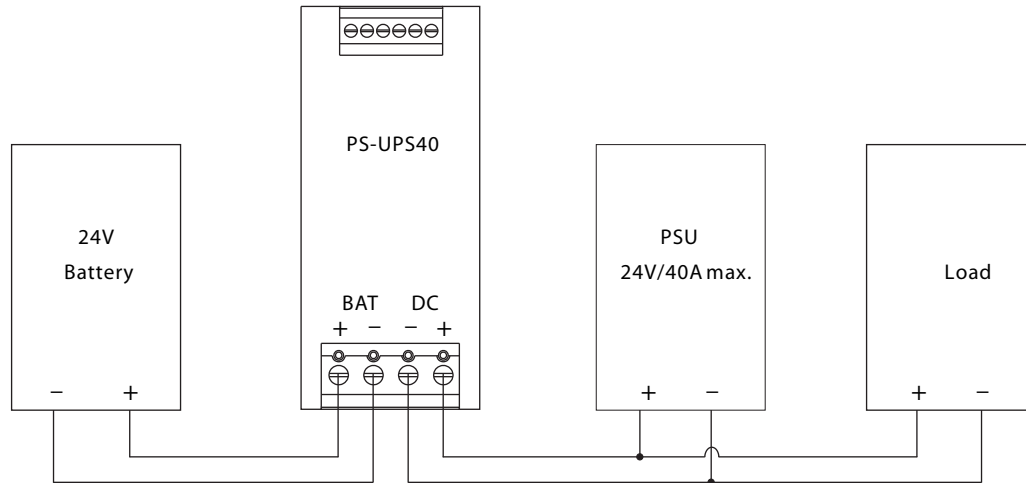

2. Combine redundancy module (PS-RDN20) to back up AC interruption or failure of PSU

