

M62440FP

Electric Volume Control with Tone Controller for 4-Speaker Applications

REJ03F0211-0201

Rev.2.01

Mar 31, 2008

Description

The M62440FP is an IC developed for car audio, it has a built-in 4ch input selector, master volume, loudness, tone control and fader volume blocks. All of these blocks are controlled via serial data. Thank to the used zero crossing detector, very low click noise are obtained.

Features

- Built-in zero cross detector prevents click noise
- 4-input selector
- Loudness
- Tone control bass/Mid/Treble
- Master volume/Fader Volume
- Serial data control

Recommended Operating Conditions

Supply voltage range: $V_{CC} = 6$ to 9 V

$V_{DD} = 4$ to 6 V

Rated supply voltage: $V_{CC} = 8$ V

$V_{DD} = 5$ V

Block Diagram

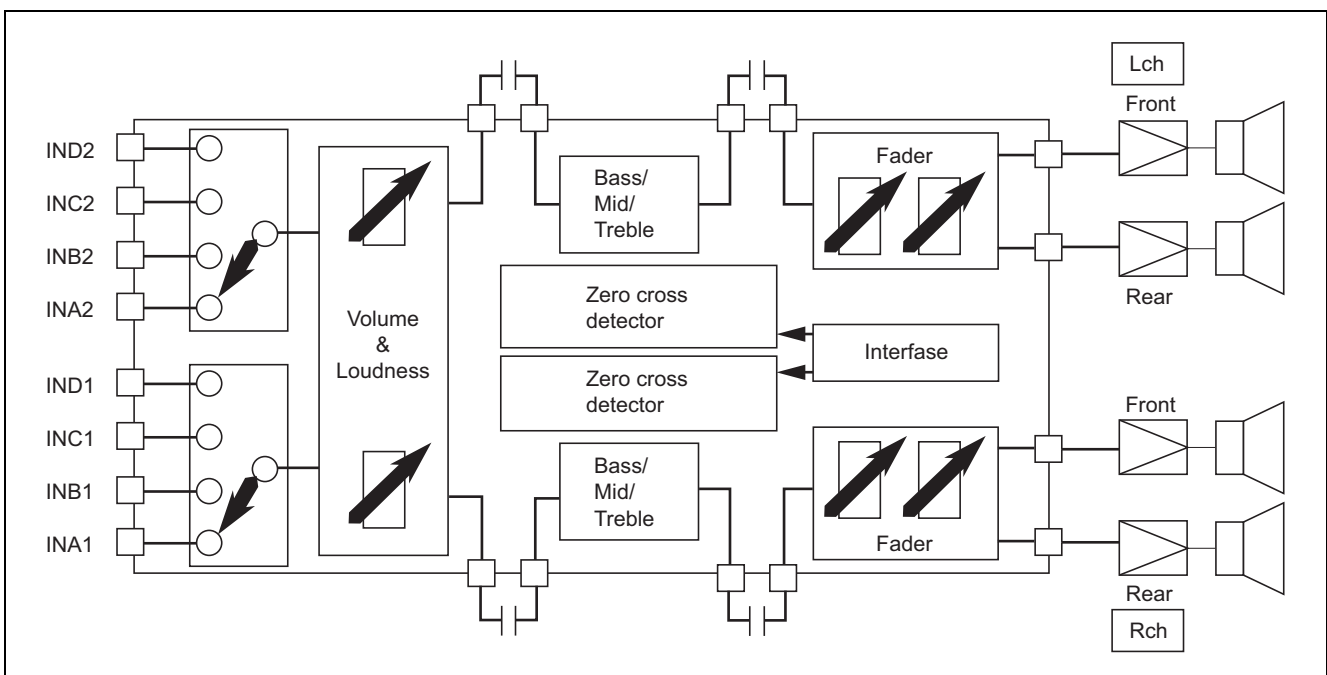

Pin Configuration and Application Example

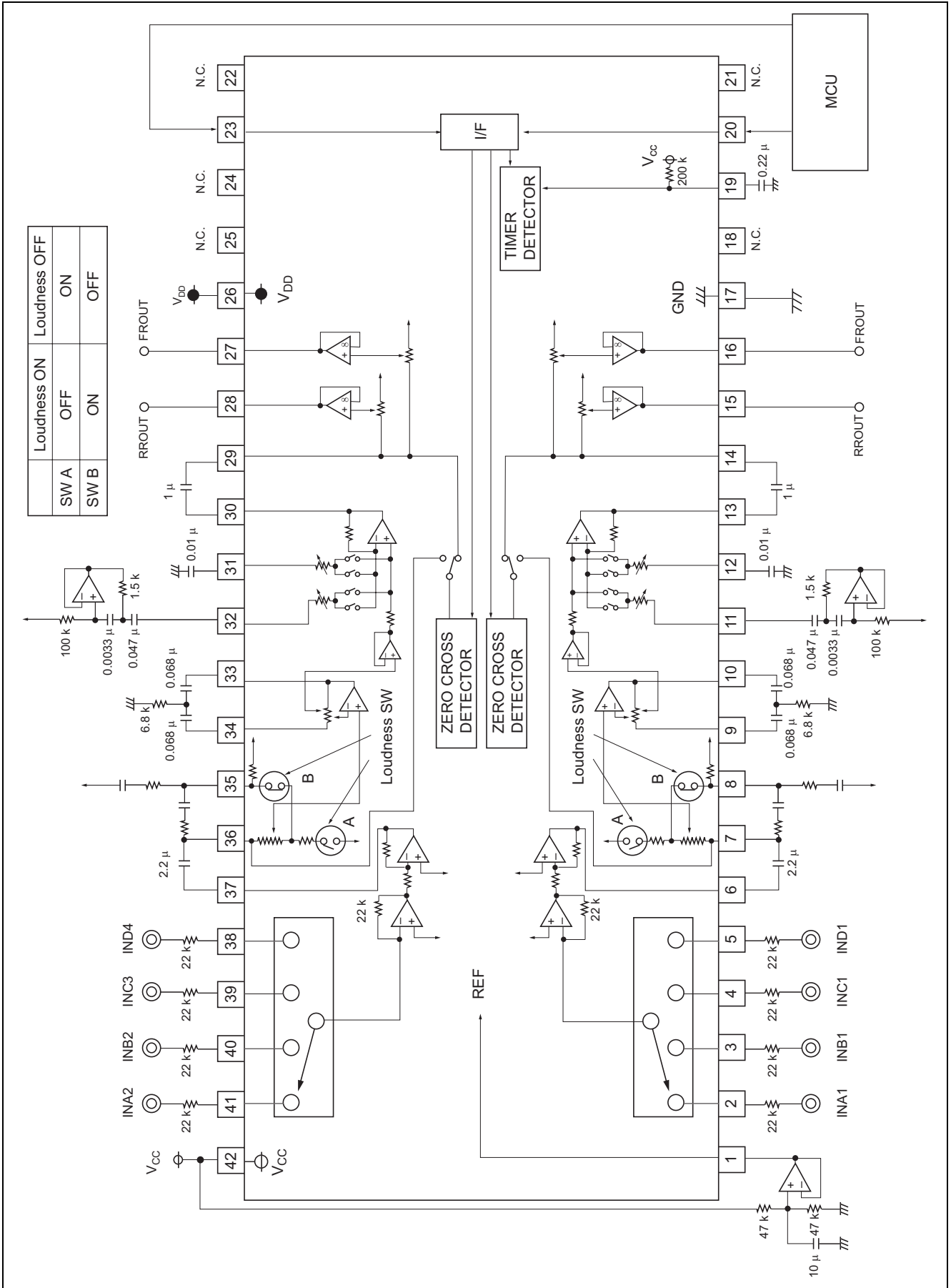

Pin Description

Pin No.	Symbol	Function
1	REF	IC signal ground. Apply 1/2 V _{CC}
2	INA1	Input pin for channel 1 of the input selector switch block
3	INB1	
4	INC1	
5	IND1	
6	SELECT OUT1	
7	VOL IN1	Input pin of the volume block
8	LOUD IN1	Pin for setting the frequency characteristics of the loudness block
9	BASSA1	Pin for setting the frequency characteristics of the tone (Bass) block
10	BASSB1	
11	MID1	R-ladder terminal of tone (Mid)
12	TRE1	R-ladder terminal of tone (Treble)
13	TONE OUT1	Output pin of the tone block
14	FADER IN1	Input pin of the fader volume
15	REAR OUT1	Output pin of the fader volume (Rear)
16	FRONT OUT1	Output pin of the fader volume (Front)
17	GND	Ground
18	N.C.	Non Connection
19	TIM1	Timer setting terminal The relationship between outside parts C and setting time is $T = 13.8 \times 10^4 \cdot C$ (s).
20	DATA	Input pin of the control data This pin inputs data in synchronization with CLOCK
21	N.C.	Non Connection
22	N.C.	Non Connection
23	CLOCK	Clock input pin for serial data transfer
24	N.C.	Non Connection
25	N.C.	Non Connection
26	V _{DD}	Digital power supply pin, normally +5 V
27	FRONT OUT2	Output pin of the fader volume (Front)
28	REAR OUT2	Output pin of the fader volume (Rear)
29	FADER IN2	Input pin of the fader volume
30	TONE OUT2	Output pin of the tone block
31	TRE2	R-ladder terminal of tone (Treble)
32	MID2	R-ladder terminal of tone (Mid)
33	BASSB2	Pin for setting the frequency characteristics of the tone (Bass) block
34	BASSA2	
35	LOUD IN2	Pin for setting the frequency characteristics of the loudness block
36	VOL IN2	Input pin of the volume block
37	SELECT OUT2	Output pin of the input selector switch block
38	IND2	Input pin for channel 2 of the input selector switch block
39	INC2	
40	INB2	
41	INA2	
42	V _{CC}	

Absolute Maximum Ratings

Item	Symbol	Ratings	Unit	Conditions
Supply voltage	V_{CC}, V_{DD}	10, 7	V	—
Power dissipation	P_d	990	mW	$T_a \leq 25^\circ\text{C}$
Thermal derating ratio	$K\theta$	9.9	mW/°C	$T_a \geq 25^\circ\text{C}$
Operating temperature	T_{opr}	-30 to 85	°C	—
Storage temperature	T_{stg}	-55 to 125	°C	—

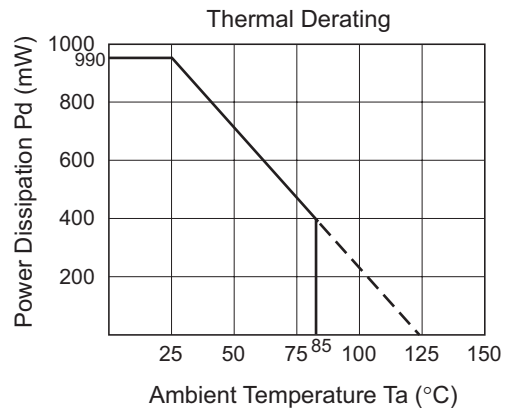

Electrical Characteristics

$T_a = 25^\circ\text{C}$, $V_{CC} = 8\text{ V}$, $V_{DD} = 5\text{ V}$, VOL/FADER = 0 dB, TONE/FLAT, Loudness OFF unless otherwise noted

Item	Symbol	Limits			Unit	Test Conditions
		Min	Typ	Max		
Circuit current	I_{CC}	—	20	35	mA	No input signal
Pass gain	Gv	-3.5	0	3.5	dB	Outside resistor 22 k Ω of pin 2 to 5, pin 38 ~ 41
Maximum attenuation	A_{TT} (VOL)	-32.5	-30	-27.5	dB	$V_i = 1\text{ V}_{rms}$, $f = 1\text{ kHz}$ A_{TT} (VOL) = -30 dB
Attenuation error	ΔA_{TT} (VOL)	-2.5	0	2.5	dB	A_{TT} (VOL) = 0 dB
Maximum input voltage	V_{IM}	1.8	2.2	—	V _{rms}	$f = 1\text{ kHz}$, BW: 400 ~ 30 kHz THD = 1%
Bass boost	G (Bass) B	13	16	19	dB	$f = 100\text{ Hz}$
Bass cut	G (Bass) C	-15	-12	-9	dB	$f = 100\text{ Hz}$
MID boost	G (MID) B	9	12	15	dB	$f = 1\text{ kHz}$
MID cut	G (MID) C	-15	-12	-9	dB	$f = 1\text{ kHz}$
Treble boost	G (Tre) B	9	12	15	dB	$f = 10\text{ kHz}$
Treble cut	G (Tre) C	-15	-12	-9	dB	$f = 10\text{ kHz}$
Maximum attenuation	A_{TT} (FED)	—	-90	-80	dB	$V_i = 1\text{ V}_{rms}$, $f = 1\text{ kHz}$ A_{TT} (FED) = $-\infty$ dB
Maximum output voltage	V_{OM}	1.8	2.2	—	V _{rms}	$f = 1\text{ kHz}$, BW: 400 to 30 kHz THD = 1%
Output noise voltage	V_{no1}	—	10	18	μV_{rms}	$R_g = 0$, DIN-AUDIO
	V_{no2}	—	3	8		A_{TT} (VOL) = -30 dB A_{TT} (FED) = $-\infty$ dB $R_g = 0$, DIN-AUDIO
Total harmonic distortion	THD	—	0.01	0.05	%	$f = 1\text{ kHz}$, $V_o = 0.5\text{ V}_{rms}$ BW: 400 Hz to 30 kHz
Channel separation	CS	—	-90	-80	dB	$f = 1\text{ kHz}$
Cross talk of input selector	CT	—	-75	-65	dB	$f = 1\text{ kHz}$
Voltage gain of loudness	G (LOUD) L	7.0	11.0	15.0	dB	Loudness ON $f = 100\text{ Hz}$, A_{TT} (VOL) = -30 dB
	G (LOUD) H	3.5	6.5	9.5		Loudness ON $f = 10\text{ kHz}$, A_{TT} (VOL) = -30 dB

Relationship between Data and Clock

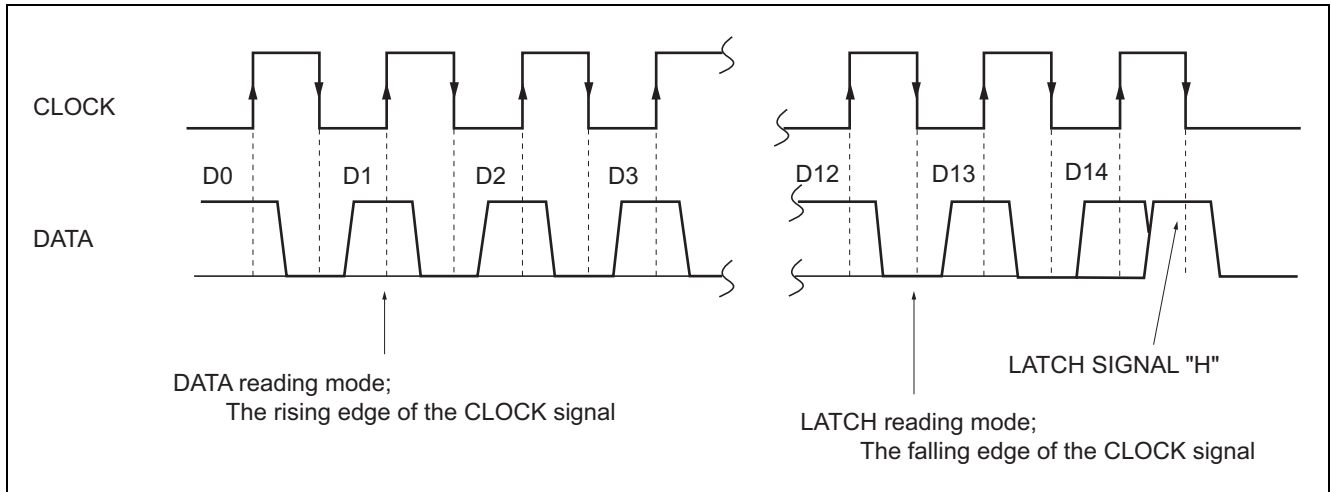

Digital Circuit DC Characteristics

Item	Symbol	Limits			Unit	Test Conditions	
		Min	Typ	Max			
"L" level input voltage	V_{IL}	0	~	$0.2 V_{DD}$	V	DATA, CLOCK pins	
"H" level input voltage	V_{IH}	$0.8 V_{DD}$	~	V_{DD}			
"L" level input current	I_{IL}	-10	—	10	μA	$V_I = 0$	DATA, CLOCK pins
"H" level input current	I_{IH}	—	—	10		$V_I = V_{DD}$	

Digital Circuit AC Characteristics

Item	Symbol	Limits			Unit
		Min	Typ	Max	
CLOCK cycle time	t_{cr}	4	—	—	μs
CLOCK pulse width ("H" level)	t_{WHC}	1.6	—	—	
CLOCK pulse width ("L" level)	t_{WLC}	1.6	—	—	
CLOCK rise time	t_r	—	—	0.4	
CLOCK fall time	t_f	—	—	0.4	
DATA setup time	t_{SD}	0.8	—	—	
DATA hold time	t_{HD}	0.8	—	—	

Clock Data Timing

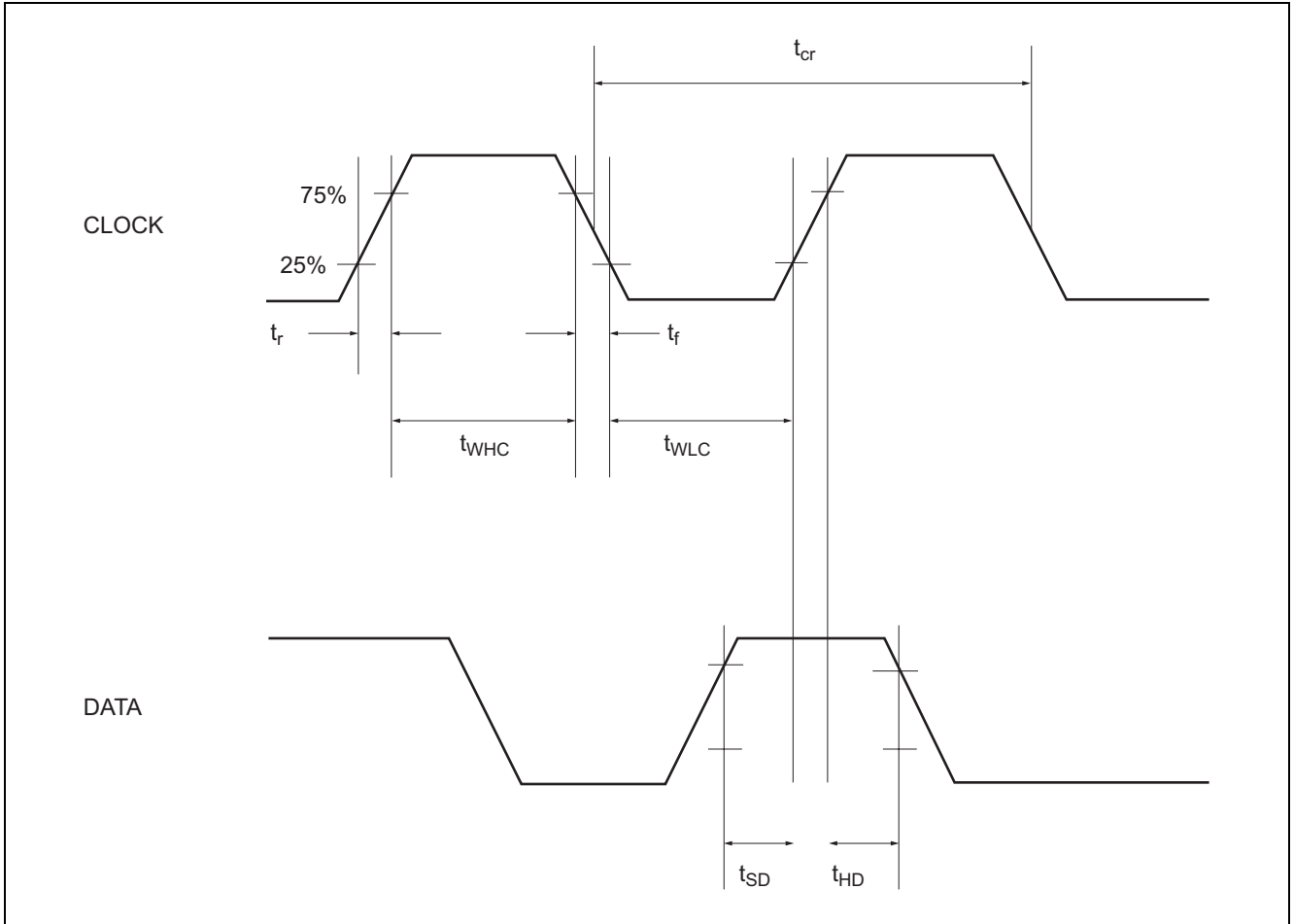

Data Input Format

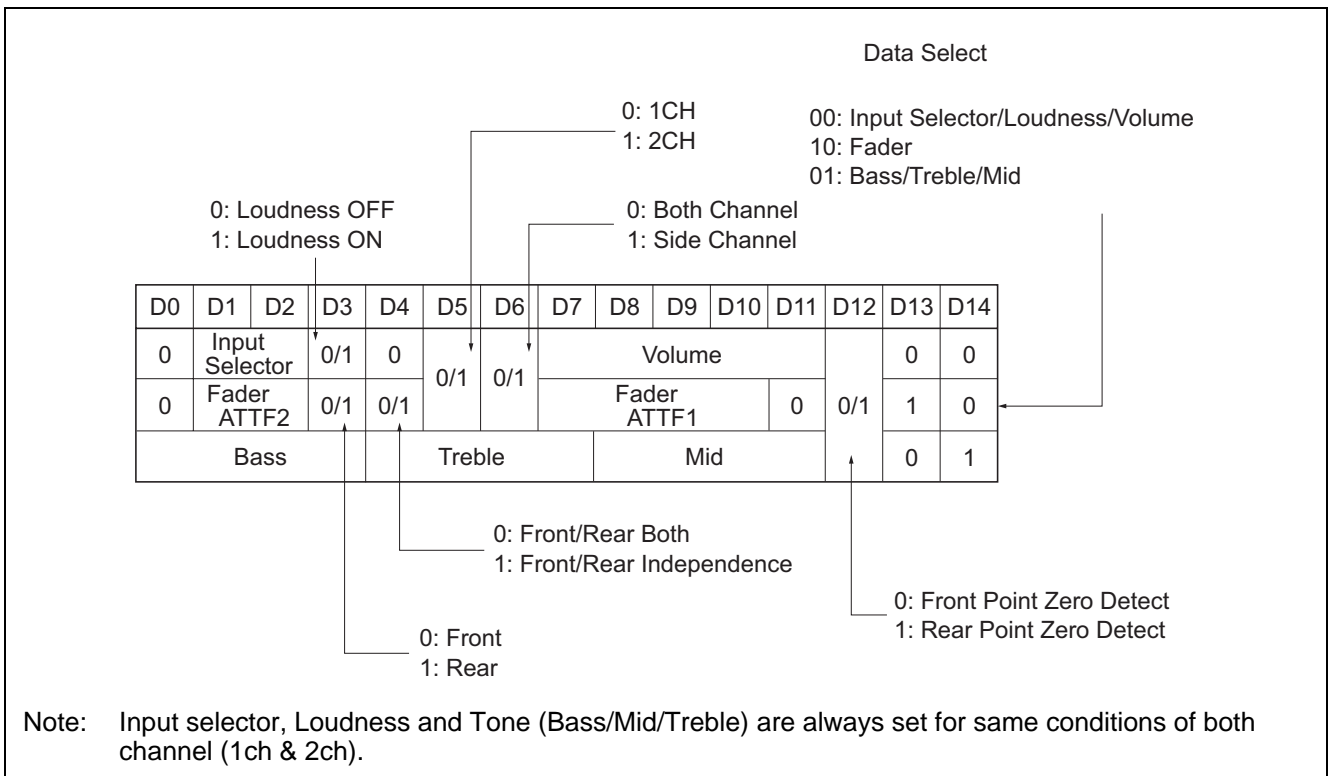

Volume Code

ATT V1	D7	D8	D9
0 dB	1	0	1
-4 dB	0	0	1
-8 dB	1	1	0
-12 dB	0	1	0
-16 dB	1	0	0
-20 dB	0	0	0
-24 dB	0	1	1
-28 dB	1	1	1

ATT V2	D10	D11
0 dB	1	1
-1 dB	0	1
-2 dB	1	0
-3 dB	0	0

Fader Code

ATT F1	D7	D8	D9	D10
0 dB	1	0	0	1
-8 dB	1	1	1	0
-16 dB	0	1	1	0
-24 dB	1	0	1	0
-32 dB	0	0	1	0
-40 dB	1	1	0	0
-48 dB	0	1	0	0
-56 dB	1	0	0	0
-∞ dB	0	0	0	0

ATT F2	D1	D2
0 dB	1	1
-2 dB	0	1
-4 dB	1	0
-6 dB	0	0

Tone Code

Bass	D0	D1	D2	D3
16 dB	0	0	0	1
14 dB	1	1	1	0
12 dB	0	1	1	0
10 dB	1	0	1	0
8 dB	0	0	1	0
6 dB	1	1	0	0
4 dB	0	1	0	0
2 dB	1	0	0	0
0 dB	0	0	0	0
-2 dB	1	0	0	1
-4 dB	0	1	0	1
-6 dB	1	1	0	1
-8 dB	0	0	1	1
-10 dB	1	0	1	1
-12 dB	0	1	1	1

Treble	D4	D5	D6	D7
12 dB	0	1	1	0
10 dB	1	0	1	0
8 dB	0	0	1	0
6 dB	1	1	0	0
4 dB	0	1	0	0
2 dB	1	0	0	0
0 dB	0	0	0	0
-2 dB	1	0	0	1
-4 dB	0	1	0	1
-6 dB	1	1	0	1
-8 dB	0	0	1	1
-10 dB	1	0	1	1
-12 dB	0	1	1	1

Mid	D8	D9	D10	D11
12 dB	0	1	1	0
10 dB	1	0	1	0
8 dB	0	0	1	0
6 dB	1	1	0	0
4 dB	0	1	0	0
2 dB	1	0	0	0
0 dB	0	0	0	0
-2 dB	1	0	0	1
-4 dB	0	1	0	1
-6 dB	1	1	0	1
-8 dB	0	0	1	1
-10 dB	1	0	1	1
-12 dB	0	1	1	1

Input Selector

Input Selector	D1	D2
D (5, 38 pin)	1	1
C (4, 39 pin)	1	0
B (3, 40 pin)	0	1
A (2, 41 pin)	0	0

Package Dimensions

42P2R-A



Plastic 42pin 450mil SSOP

EIAJ Package Code	JEDEC Code	Weight(g)	Lead Material
SSOP42-P-450-0.80	—	0.63	Alloy 42/Cu Alloy

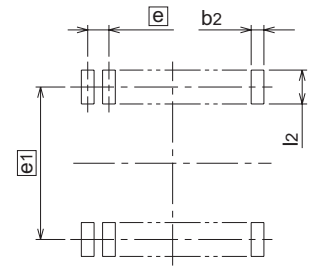
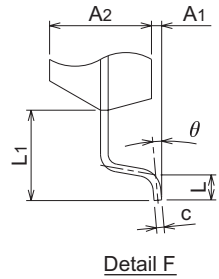
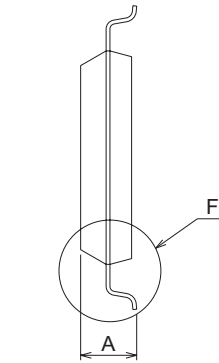
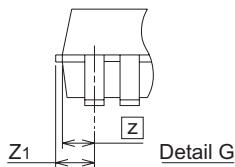
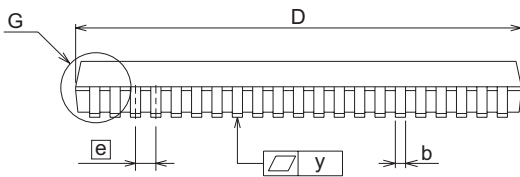
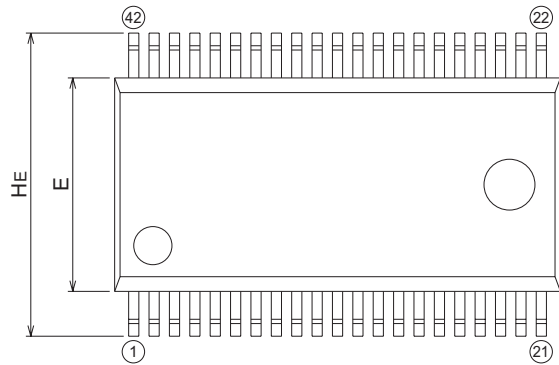

Recommended Mount Pad

Symbol	Dimension in Millimeters		
	Min	Nom	Max
A	—	—	2.4
A1	0.05	—	—
A2	—	2.0	—
b	0.35	0.4	0.5
c	0.13	0.15	0.2
D	17.3	17.5	17.7
E	8.2	8.4	8.6
e	—	0.8	—
HE	11.63	11.93	12.23
L	0.3	0.5	0.7
L1	—	1.765	—
Z	—	0.75	—
Z1	—	—	0.9
y	—	—	0.15
theta	0°	—	10°
b2	—	0.5	—
e1	—	11.43	—
l2	1.27	—	—

Notes:

1. This document is provided for reference purposes only so that Renesas customers may select the appropriate Renesas products for their use. Renesas neither makes warranties or representations with respect to the accuracy or completeness of the information contained in this document nor grants any license to any intellectual property rights or any other rights of Renesas or any third party with respect to the information in this document.
2. Renesas shall have no liability for damages or infringement of any intellectual property or other rights arising out of the use of any information in this document, including, but not limited to, product data, diagrams, charts, programs, algorithms, and application circuit examples.
3. You should not use the products or the technology described in this document for the purpose of military applications such as the development of weapons of mass destruction or for the purpose of any other military use. When exporting the products or technology described herein, you should follow the applicable export control laws and regulations, and procedures required by such laws and regulations.
4. All information included in this document such as product data, diagrams, charts, programs, algorithms, and application circuit examples, is current as of the date this document is issued. Such information, however, is subject to change without any prior notice. Before purchasing or using any Renesas products listed in this document, please confirm the latest product information with a Renesas sales office. Also, please pay regular and careful attention to additional and different information to be disclosed by Renesas such as that disclosed through our website. (<http://www.renesas.com>)
5. Renesas has used reasonable care in compiling the information included in this document, but Renesas assumes no liability whatsoever for any damages incurred as a result of errors or omissions in the information included in this document.
6. When using or otherwise relying on the information in this document, you should evaluate the information in light of the total system before deciding about the applicability of such information to the intended application. Renesas makes no representations, warranties or guarantees regarding the suitability of its products for any particular application and specifically disclaims any liability arising out of the application and use of the information in this document or Renesas products.
7. With the exception of products specified by Renesas as suitable for automobile applications, Renesas products are not designed, manufactured or tested for applications or otherwise in systems the failure or malfunction of which may cause a direct threat to human life or create a risk of human injury or which require especially high quality and reliability such as safety systems, or equipment or systems for transportation and traffic, healthcare, combustion control, aerospace and aeronautics, nuclear power, or undersea communication transmission. If you are considering the use of our products for such purposes, please contact a Renesas sales office beforehand. Renesas shall have no liability for damages arising out of the uses set forth above.
8. Notwithstanding the preceding paragraph, you should not use Renesas products for the purposes listed below:
 - (1) artificial life support devices or systems
 - (2) surgical implantations
 - (3) healthcare intervention (e.g., excision, administration of medication, etc.)
 - (4) any other purposes that pose a direct threat to human lifeRenesas shall have no liability for damages arising out of the uses set forth in the above and purchasers who elect to use Renesas products in any of the foregoing applications shall indemnify and hold harmless Renesas Technology Corp., its affiliated companies and their officers, directors, and employees against any and all damages arising out of such applications.
9. You should use the products described herein within the range specified by Renesas, especially with respect to the maximum rating, operating supply voltage range, movement power voltage range, heat radiation characteristics, installation and other product characteristics. Renesas shall have no liability for malfunctions or damages arising out of the use of Renesas products beyond such specified ranges.
10. Although Renesas endeavors to improve the quality and reliability of its products, IC products have specific characteristics such as the occurrence of failure at a certain rate and malfunctions under certain use conditions. Please be sure to implement safety measures to guard against the possibility of physical injury, and injury or damage caused by fire in the event of the failure of a Renesas product, such as safety design for hardware and software including but not limited to redundancy, fire control and malfunction prevention, appropriate treatment for aging degradation or any other applicable measures. Among others, since the evaluation of microcomputer software alone is very difficult, please evaluate the safety of the final products or system manufactured by you.
11. In case Renesas products listed in this document are detached from the products to which the Renesas products are attached or affixed, the risk of accident such as swallowing by infants and small children is very high. You should implement safety measures so that Renesas products may not be easily detached from your products. Renesas shall have no liability for damages arising out of such detachment.
12. This document may not be reproduced or duplicated, in any form, in whole or in part, without prior written approval from Renesas.
13. Please contact a Renesas sales office if you have any questions regarding the information contained in this document, Renesas semiconductor products, or if you have any other inquiries.



RENESAS SALES OFFICES

<http://www.renesas.com>

Refer to "<http://www.renesas.com/en/network>" for the latest and detailed information.

Renesas Technology America, Inc.
450 Holger Way, San Jose, CA 95134-1368, U.S.A
Tel: <1> (408) 382-7500, Fax: <1> (408) 382-7501

Renesas Technology Europe Limited
Dukes Meadow, Millboard Road, Bourne End, Buckinghamshire, SL8 5FH, U.K.
Tel: <44> (1628) 585-100, Fax: <44> (1628) 585-900

Renesas Technology (Shanghai) Co., Ltd.
Unit 204, 205, AZIACenter, No.1233 Lujiazui Ring Rd, Pudong District, Shanghai, China 200120
Tel: <86> (21) 5877-1818, Fax: <86> (21) 6887-7858/7898

Renesas Technology Hong Kong Ltd.
7th Floor, North Tower, World Finance Centre, Harbour City, Canton Road, Tsimshatsui, Kowloon, Hong Kong
Tel: <852> 2265-6688, Fax: <852> 2377-3473

Renesas Technology Taiwan Co., Ltd.
10th Floor, No.99, Fushing North Road, Taipei, Taiwan
Tel: <886> (2) 2715-2888, Fax: <886> (2) 3518-3399

Renesas Technology Singapore Pte. Ltd.
1 Harbour Front Avenue, #06-10, Keppel Bay Tower, Singapore 098632
Tel: <65> 6213-0200, Fax: <65> 6278-8001

Renesas Technology Korea Co., Ltd.
Kukje Center Bldg. 18th Fl., 191, 2-ka, Hangang-ro, Yongsan-ku, Seoul 140-702, Korea
Tel: <82> (2) 796-3115, Fax: <82> (2) 796-2145

Renesas Technology Malaysia Sdn. Bhd
Unit 906, Block B, Menara Amcorp, Amcorp Trade Centre, No.18, Jln Persiaran Barat, 46050 Petaling Jaya, Selangor Darul Ehsan, Malaysia
Tel: <603> 7955-9390, Fax: <603> 7955-9510