

FD7T Series Multi-Output CMOS Clock Oscillator

May 2008

- Pletronics' FD7T Series is a quartz crystal controlled precision square wave generator with multiple independent CMOS outputs
- Output frequencies from 12 KHz to 230 MHz
- Selectable low jitter or spread spectrum outputs.
- Device characteristics may be either factory or field programmable
- 1.8V, 2.5 or 3.3V LVCMOS outputs
- 5 x 7 mm LCC Ceramic Package
- Low power
- This is a low cost, mass produced oscillator.
- Tape and Reel or cut tape packaging is available.
- The package is designed for high density surface mount designs

Model Number	PLLs	Outputs
FD77xxT	4	7
FD75xxT	3	5
FD74xxT	2	4
FD73xxT	1	3

Pletronics Inc. certifies this device is in accordance with the RoHS 6/6 (2002/95/EC) and WEEE (2002/96/EC) directives.

Pletronics Inc. guarantees the device does not contain the following:

Cadmium, Hexavalent Chromium, Lead, Mercury, PBB's, PBDE's

Weight of the Device: 0.17 grams

Moisture Sensitivity Level: 1 As defined in J-STD-020C

Second Level Interconnect code: e4

Absolute Maximum Ratings:

Parameter	Unit
V_{DD}	-0.5V to +2.5V
V_{DDOUT}	-0.5V to +4.6V
V_i Input Voltage	-0.5V to $V_{DD} + 0.5V$
V_o Output Voltage	-0.5V to $V_{DDOUT} + 0.5V$
I_o Continuous Output Current	± 50 mA
T_j Maximum Junction Temperature	125°C
Thermal Resistance, Junction to Case	50°C/Watt

BLOCK DIAGRAMS OF THE FD7T SERIES

FD73xxT

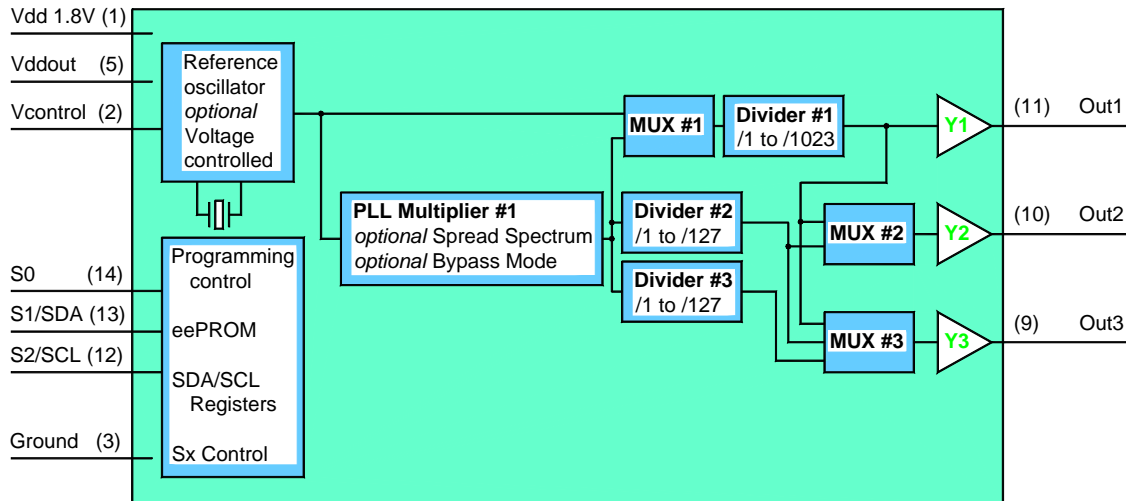

FD74xxT

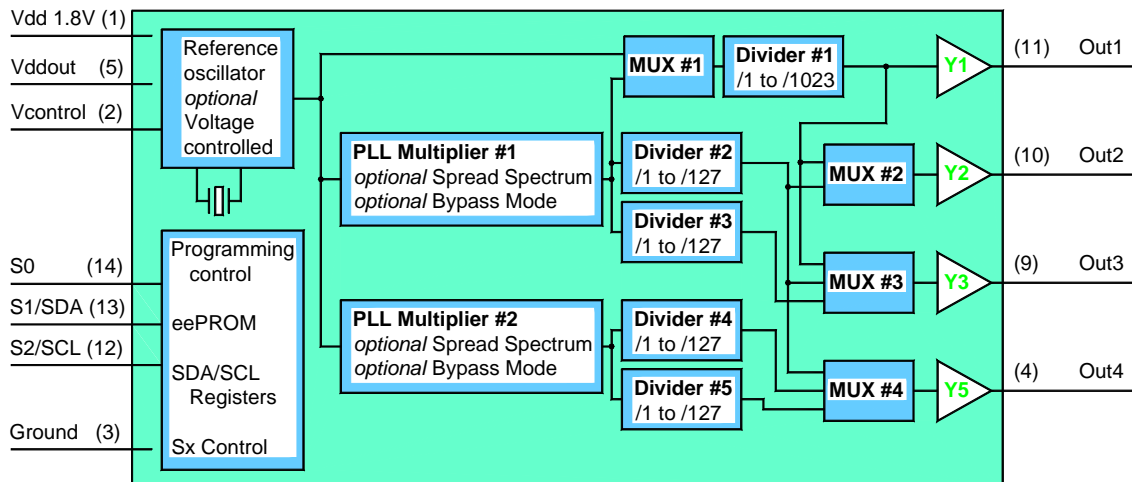

FD75xxT



FD77xxT

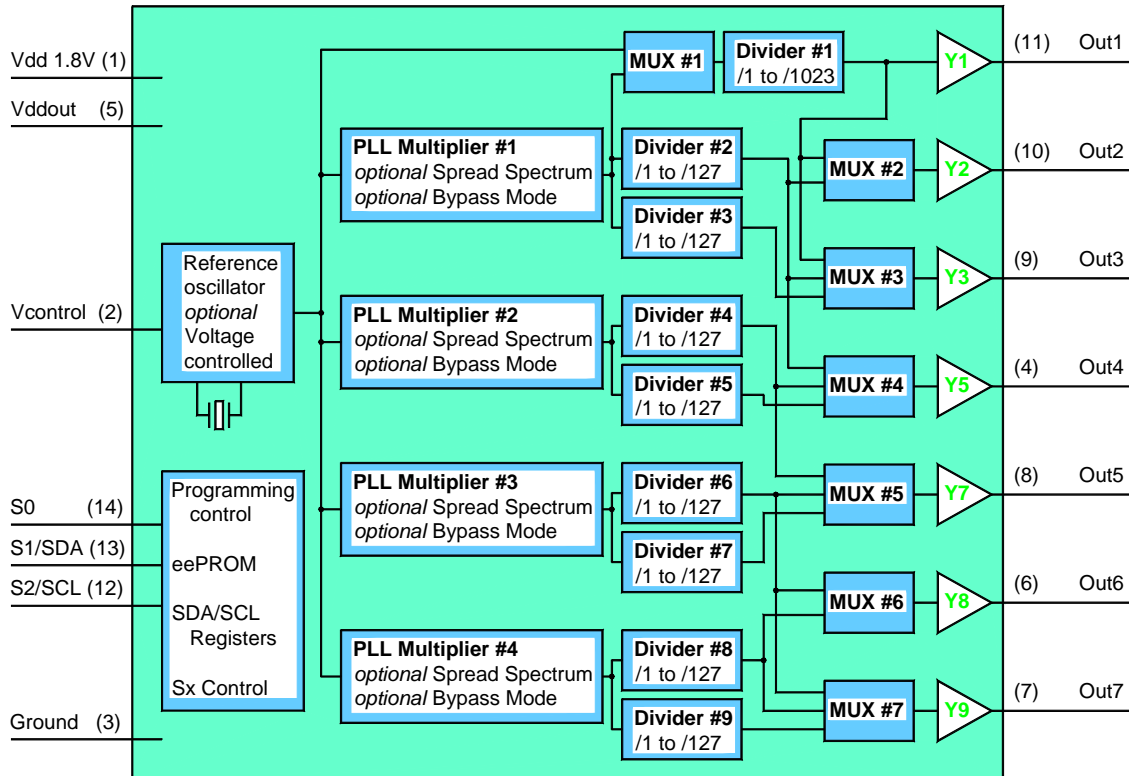

Description:

The FD7T series Multi-Output CMOS Clock Oscillator is a modular PLL-based low cost, high-performance, programmable oscillator. The FD7T generates up to seven output frequencies, OUT1 through OUT7. Frequencies are mutually independent and may be programmed to any frequency from 100KHz to 230-MHz and one output can be as low as 12KHz. There are versions including 1 to 4 PLLs, the number of PLLs impacts the cost.

The FD7T base frequency, as noted in the device part number, is established during manufacture and is permanently fixed. For convenience, the divider for output OUT1 and the remaining seven output frequencies, and their characteristics may be pre-programmed at the factory, or field programmed.

The FD7T has a separate output supply pin, V_{DDOUT} , for either 1.8, 2.5 or 3.3V output logic levels. The device supply, V_{DD} which provides power to all the internal circuits, is nominally 1.8V.

The FD7xxxTL version has increased output drive for then 1.8V output levels. This version can be used at 1.8V V_{DDOUT} only.

The deep M/N PLL divider ratio allows the generation of zero-ppm clocks for applications such as WLAN, BlueTooth, Ethernet, GPS, USB, IEEE1394, etc. from the base frequency.

Each of the independent PLLs supports Spread Spectrum Clocking (SSC). SSC may be programmed to be either center-spread or down-spread. This is an important technique to reduce electro-magnetic interference (EMI).

The device supports non-volatile eePROM programming for easy customization of the device. As shipped, the device is pre-programmed. Standard combinations are denoted by three characters in the device part number. However, the FD7T may be reprogrammed to a different configuration. Reprogramming may be either prior to assembly, or in-circuit via a 2-wire SDA/SCL I²C bus.

Three programmable control inputs, S0, S1 and S2, may be used to control various aspects of FD7T operation including selection of alternative frequency set(s), selection of SSC functionality, output tri-state and power-down.

Reference Oscillator

The Reference Oscillator is an AT cut quartz crystal based oscillator. This oscillator is very similar to the Pletronics SM77xxH product oscillator. This signal is the lowest jitter and can be an output on Out1, Out2 or Out3 and can be divided down by the Divider #1. The user may specify any frequency between 12MHz and 32MHz for this reference. All output frequencies are derived from (referenced to) this Reference Oscillator.

Reference Oscillator - VCXO

The reference oscillator frequency can be modulated by the Vcontrol input, if the VCXO option is selected. As this Reference Signal is the reference for all other parts of this circuit, all PLLs will be modulated also.

The VCXO input has a limited voltage range, the VCXO is associated with the internal 1.8V core. A resistor in series with the Vcontrol input will permit interfacing to 3.3V analog circuits, the voltage range that changes the frequency will still be limited but the larger voltages swings will not cause problems.

PLL Multipliers

There are up to 4 each independent PLL Multipliers and these can multiply the Reference Oscillator frequency from 1 (bypass mode) to any value that is $\leq 230\text{MHz}$ (the lowest frequency is the Reference Oscillator frequency).

Each of the PLL Multipliers can have two setup options, 0 or 1, depending on which option is chosen and set by the Sx control signals and the user's definitions are stored in eePROM.

Spread Spectrum

Each PLL has its individual Spread Spectrum (SS) function that can be enabled. This permits the modulation of the output frequency by a user-set amount. The modulation can be centered on the output frequency or down side only. Which of the 1 of 8 SS settings is being used is set by the Sx input and the user definition. The value is a percentage of the output frequency that will be modulated.

SS Option	Down Side Modulation	Centered Modulation
0	No SS	No SS
1	-0.25%	$\pm 0.25\%$
2	-0.50%	$\pm 0.50\%$
3	-0.75%	$\pm 0.75\%$
4	-1.00%	$\pm 1.00\%$
5	-1.25%	$\pm 1.25\%$
6	-1.50%	$\pm 1.50\%$
7	-2.00%	$\pm 2.00\%$

Divider Section

The dividers operate on the output of the PLLs. There are two dividers on each PLL that divide by 1 through 127, the value is user defined. There is only 1 setting allowed per divider. These are not set by the Sx input state.

The dividers add very little jitter to the output signals.

Multiplexers

MUX #1 selects the input to the Divider #1, this can be the reference oscillator signal or the output from PLL Multiplier #1. MUX #2 through MUX #7 connect various divider outputs to the output buffers.

The device can make only one of the setting of connections shown in the block diagram (only one pattern stored in eePROM).

Output Buffers

Each output buffer can have 3 modes of operation:

- 1) Tri State 2) Active Low 3) The signal output of the Multiplexer

The output buffers for Out2 and Out3 and the output buffers Out6 and Out7 function as pairs. When selecting on the function both outputs in the pair function the same.

There can be two options stored for the Output Buffers, State 0 and State 1. The eight Sx input settings can have assigned one of the two Output Buffer states for each of Output Buffer sets.

This permits wired 'OR' of tri-state outputs, this permits setting total enable and disable functions of all outputs.

Control Inputs

The three inputs, S0, S1/SDA and S2/SCL can be configured in two ways.

- 1) Used as 3 user inputs to permit up to 8 states, Sx input setting.
- 2) S0 used as an input to permit up to 2 states, S0 input setting. The SDA and SCL become clock and data inputs to write to the FD7T internal setting memory. The interface follows the I²C protocol. If the SDA and SCL are not set then the internal eePROM sets the operation.

The S0, S1 and S2 input signals control and variations states allowed:

Inputs			PLL #1		PLL #2		PLL #3		PLL #4		Output						
S2	S1	S0	SS	PLL	SS	PLL	SS	PLL	SS	PLL	1	2	3	4	5	6	7
0	0	0	0/7	0/1	0/7	0/1	0/7	0/1	0/7	0/1	0/1	0/1	0/1	0/1	0/1	0/1	0/1
0	0	1	0/7	0/1	0/7	0/1	0/7	0/1	0/7	0/1	0/1	0/1	0/1	0/1	0/1	0/1	0/1
0	1	0	0/7	0/1	0/7	0/1	0/7	0/1	0/7	0/1	0/1	0/1	0/1	0/1	0/1	0/1	0/1
0	1	1	0/7	0/1	0/7	0/1	0/7	0/1	0/7	0/1	0/1	0/1	0/1	0/1	0/1	0/1	0/1
1	0	0	0/7	0/1	0/7	0/1	0/7	0/1	0/7	0/1	0/1	0/1	0/1	0/1	0/1	0/1	0/1
1	0	1	0/7	0/1	0/7	0/1	0/7	0/1	0/7	0/1	0/1	0/1	0/1	0/1	0/1	0/1	0/1
1	1	0	0/7	0/1	0/7	0/1	0/7	0/1	0/7	0/1	0/1	0/1	0/1	0/1	0/1	0/1	0/1
1	1	1	0/7	0/1	0/7	0/1	0/7	0/1	0/7	0/1	0/1	0/1	0/1	0/1	0/1	0/1	0/1

The MUX inputs are fixed independent of the Sx setting.
The Divider Values are fixed independent of the Sx setting

Specifying The FD7T Device For A Specific Application

Pletronics provides an EXCEL spreadsheet based program that assists in defining the FD77T functions. The program only permits setting of parameters that will properly function. After defining the desired functions, this spreadsheet is sent to Pletronics and the Configuration Part Number will then be assigned. Pletronics uses the values in the spreadsheet to program the devices for shipment.

PART NUMBER:

FD7 7 45 T L E -25.0M -YYY -XX

	<p>Packaging code or blank T250 = 250 per Tape and Reel T500 = 500 per Tape and Reel T1K = 1000 per Tape and Reel</p>
	<p>Configuration Number This is a 3 character alpha-numeric code issued by Pletronics that defines the FD77T function (the output pin functions, the available frequencies and the pin number assignments). Each configuration is given a unique value.</p>
	<p>Base Frequency (Crystal oscillator frequency) in MHZ</p>
	<p>Optional Enhanced Operating temperature Range Blank = Temp. range -20°C to +70°C E = Temp. range -40°C to +85°C</p>
	<p>Blank = V_{DDOUT} 3.3V, 2.5V and 1.8V device L = V_{DDOUT} 1.8V only high output drive level device</p>
	<p>Series Model</p>
	<p>Frequency Stability for fixed frequency oscillator 45 = ± 50 ppm 15 = ± 15 ppm 44 = ± 25 ppm 10 = ± 10 ppm 20 = ± 20 ppm</p> <p>Frequency Pull Ability for VCXO option enabled 99 = ± 100 ppm Absolute Pull Range (APR) 75 = ± 25 ppm Absolute Pull Range (APR) 50 = ± 50 ppm Absolute Pull Range (APR)</p>
	<p>7 = 7 outputs 4 PLL version 5 = 5 outputs 3 PLL version 4 = 4 outputs 2 PLL version 3 = 3 outputs 1 PLL version</p>
	<p>Series Model</p>

Part Marking:

PLE FD7x

ZZZ

YMD

Marking Legend: PLE = Pletronics
ZZZ = configuration

All other marking is internal factory codes

X = Model type

YMD = Date of Manufacture
(year-month-day)

Codes for Date Code YMD

Code	8	9	0	1	2	Code	A	B	C	D	E	F	G	H	J	K	L	M
Year	2008	2009	2010	2011	2012	Month	JAN	FEB	MAR	APR	MAY	JUN	JUL	AUG	SEP	OCT	NOV	DEC

Code	1	2	3	4	5	6	7	8	9	A	B	C	D	E	F	G
Day	1	2	3	4	5	6	7	8	9	10	11	12	13	14	15	16
Code	H	J	K	L	M	N	P	R	T	U	V	W	X	Y	Z	
Day	17	18	19	20	21	22	23	24	25	26	27	28	29	30	31	

Electrical Specification over the specified temperature range

Item	Min	Max	Unit	Condition
Base Frequency	12	32	MHZ	
Frequency Range OUT1	0.0117	230	MHZ	Base Frequency / (1 to 1023) -or- PLL1
Frequency Range OUT2 - 7	0.0945	230	MHZ	
Frequency Accuracy	"45"	-50	+50	ppm For all supply voltages, load changes, aging for 1 year, shock, vibration and temperatures
	"44"	-25	+25	
	"20"	-20	+20	
Recommended Operating Conditions				
Device Supply Voltage V_{DD}	1.7	1.9	V	
Output Supply Voltage V_{DDOUT}	1.7	3.6	V	
Output Supply Voltage "L" V_{DDOUT}	1.7	1.9	V	
Low Level Input voltage	--	30	%	of V_{DD}
High Level Input voltage	70	--	%	of V_{DD}
Input Voltage Range, S0 If 1K ohm in series with S0 pad	0 -1	1.9 4.0	V	V_{TH} is $0.5 * V_{DD}$
Input Voltage Range, S1, S2	0	3.6	V	V_{TH} is $0.5 * V_{DD}$
Input current for: S0 with 1K ohm in series	0	3	mA	$V_{IN} = 4V$; $V_{DD} = 1.8V$
S0, S1, S2	0	5	μA	$V_{IN} = V_{DD}$; $V_{DD} = 1.9V$
	-4	0	μA	$V_{IN} = 0.0V_D$; $V_{DD} = 1.9V$
Output Current, $V_{DDOUT} = 3.3V$	-12	+12	mA	
Output Current, $V_{DDOUT} = 2.5V$	-10	+10	mA	
Output Current, $V_{DDOUT} = 1.8V$	-5	+5	mA	
Output Current "L", $V_{DDOUT} = 1.8V$	-8	+8	mA	
Output Load, LVCMOS	--	10	pf	Higher loads can be used
LVCMOS Output Parameters for $V_{DDOUT} = 3.3v$				
Output High, $V_{DDOUT} = 3.3V$	2.9	--	V	$I_{OH} = -0.1$ mA
	2.4	--	V	$I_{OH} = -8.0$ mA
	2.2	--	V	$I_{OH} = -12.0$ mA
Output Low, $V_{DDOUT} = 3.3V$	--	0.1	V	$I_{OH} = +0.1$ mA
	--	0.5	V	$I_{OH} = +8.0$ mA
	--	0.8	V	$I_{OH} = +12.0$ mA
Rise & Fall Time	--	0.6	nS	$V_{DDOUT} = 3.3v$, 20 - 80%, 10pF Load
Output Symmetry	45	55	%	at 50% point of V_{DDOUT}

Item	Min	Max	Unit	Condition
Peak-to-Peak Jitter ⁽¹⁾⁽²⁾	--	100	pS	1 PLL Switching
	--	180	pS	4 PLLs Switching
Cycle-to-Cycle Jitter ⁽¹⁾⁽²⁾	--	90	pS	1 PLL Switching
	--	170	pS	4 PLLs Switching
Output Skew	--	60	pS	OUT1 to OUT2
	--	160	pS	OUT3 to OUT7
LVC MOS Output Parameters for $V_{DDOUT} = 2.5v$				
Output High, $V_{DDOUT} = 2.5V$	2.2	--	V	$I_{OH} = -0.1$ mA
	1.7	--	V	$I_{OH} = -6.0$ mA
	1.6	--	V	$I_{OH} = -10.0$ mA
Output Low, $V_{DDOUT} = 2.5V$	--	0.1	V	$I_{OH} = +0.1$ mA
	--	0.5	V	$I_{OH} = +6.0$ mA
	--	0.7	V	$I_{OH} = +10.0$ mA
Rise & Fall Time	--	0.6	nS	$V_{DDOUT} = 2.5v$, 20 - 80%, 10pF Load
Output Symmetry	45	55	%	at 50% point of V_{DDOUT}
Peak-to-Peak Jitter ⁽¹⁾⁽²⁾	--	100	pS	1 PLL Switching
	--	180	pS	4 PLLs Switching
Cycle-to-Cycle Jitter ⁽¹⁾⁽²⁾	--	90	pS	1 PLL Switching
	--	170	pS	4 PLLs Switching
Output Skew	--	60	pS	OUT1 to OUT2
	--	160	pS	OUT3 to OUT7
LVC MOS Output Parameters for $V_{DDOUT} = 1.8v$				
Output High, $V_{DDOUT} = 1.8V$	1.6	--	V	$I_{OH} = -0.1$ mA
	1.4	--	V	$I_{OH} = -3.0$ mA
	1.1	--	V	$I_{OH} = -6.0$ mA
Output Low, $V_{DDOUT} = 1.8V$	--	0.1	V	$I_{OH} = +0.1$ mA
	--	0.3	V	$I_{OH} = +3.0$ mA
	--	0.6	V	$I_{OH} = +6.0$ mA
Rise & Fall Time	--	0.9	nS	$V_{DDOUT} = 1.8v$, 20 - 80%, 10pF Load
Output Symmetry	45	55	%	at 50% point of V_{DDOUT}
Peak-to-Peak Jitter ⁽¹⁾⁽²⁾	--	140	pS	1 PLL Switching
	--	190	pS	4 PLLs Switching
Cycle-to-Cycle Jitter ⁽¹⁾⁽²⁾	--	120	pS	1 PLL Switching
	--	170	pS	4 PLLs Switching

Item	Min	Max	Unit	Condition
Output Skew	--	60	pS	OUT1 to OUT2
	--	160	pS	OUT3 to OUT7
LVC MOS Output Parameters for $V_{DDOUT} = 1.8V$ "L" Version				
Output High, $V_{DDOUT} = 1.8V$	1.6	--	V	$I_{OH} = -0.1$ mA
	1.4	--	V	$I_{OH} = -4.0$ mA
	1.1	--	V	$I_{OH} = -8.0$ mA
Output Low, $V_{DDOUT} = 1.8V$	--	0.1	V	$I_{OH} = +0.1$ mA
	--	0.3	V	$I_{OH} = +4.0$ mA
	--	0.6	V	$I_{OH} = +8.0$ mA
Rise & Fall Time		0.7	nS	$V_{DDOUT} = 1.8V$, 20 - 80%, 10pF Load
Output Symmetry	45	55	%	at 50% point of V_{DDOUT}
Peak-to-Peak Jitter ⁽¹⁾⁽²⁾	--	140	pS	1 PLL Switching
	--	190	pS	4 PLLs Switching
Cycle-to-Cycle Jitter ⁽¹⁾⁽²⁾	--	120	pS	1 PLL Switching
	--	170	pS	4 PLLs Switching
Output Skew	--	60	pS	OUT1 to OUT2
	--	160	pS	OUT3 to OUT7
VCXO Function				
Vcontrol Input Range Usable	0.5	$V_{DD} - 0.5V$	V	The slope is positive
Vcontrol Input Range Allowed - Direct connect to Vcontrol - Limit current to $\pm 3mA$	0.0 -1.0	V_{DD} 4.0	V	The slope is positive Recommend $\geq 1K$ ohm to Vcontrol
Pull Ability specified in the P.N.				
Linearity	-10	+10	%	

(1) 10,000 cycles

(2) Jitter depends on the device configuration. Data is taken under the following conditions: 1-PLL; 27MHz Crystal, Out2 and Out3 are 27MHz (measured at Out2). 4-PLL; 27MHz Crystal, Out2 and Out3 are 27MHz (measured at Out2). Out4 is 16.384MHz, Out5 is 74.25MHz, Out6 and Out7 are 48MHz.

Frequency Tolerance:

For the FD7x15T and the FD7x10T devices, Pletronics recommends that the tight tolerance be required on the PLL outputs only. In this case the reference frequency output would only achieve $\pm 25ppm$ tolerance. This will reduce the cost of the device.

FD7xxxT I_{DDOUT} Current for Various Number of Outputs On No Load $V_{DD}=1.8V$

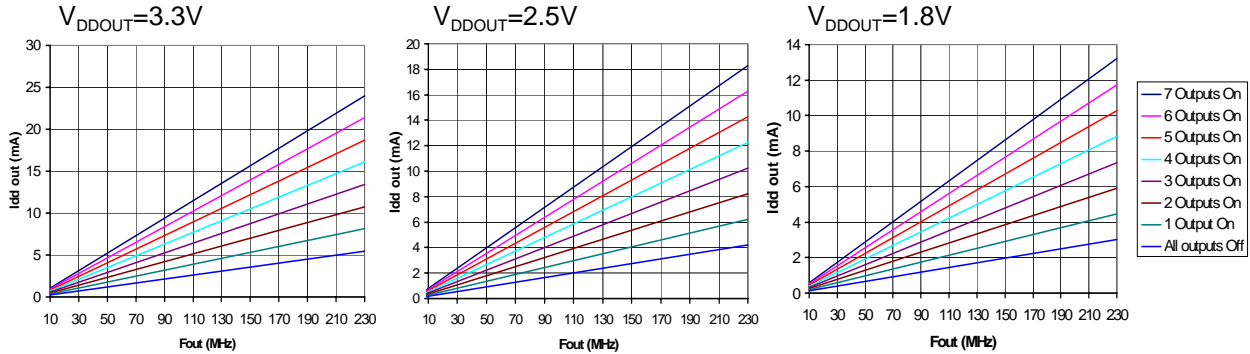

FD7xxxTL $V_{DD} = V_{DDOUT} = 1.8V$ No Load

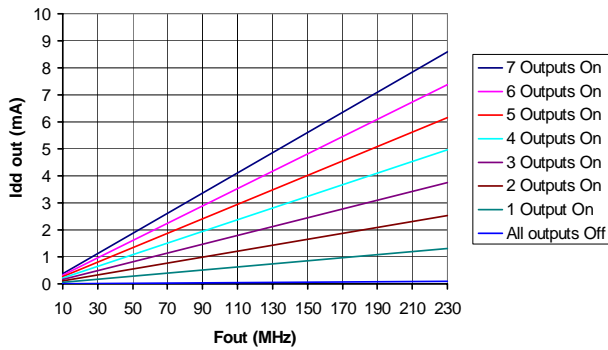

FD7 Series I_{DD} versus PLLs Used $V_{DD} = 1.8V$

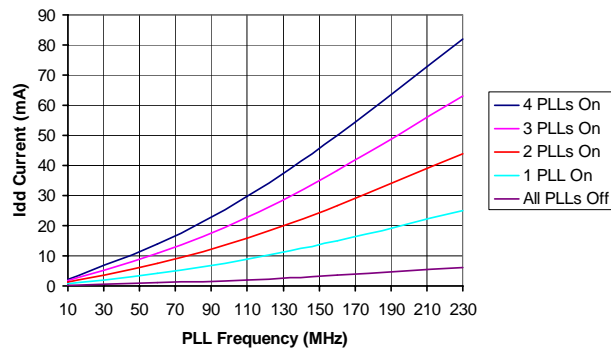

Phase noise of the reference signal, Out1.
25MHz Reference Frequency

RMS jitter is 1.4pS from 10Hz to 2MHz

Example of the PLL synthesizing a frequency.
25MHz Reference Frequency
Multiply by 8 to 200MHz
Divide the 200MHz PLL output by 8
Phase noise plot of the resulting 25MHz on Out 2

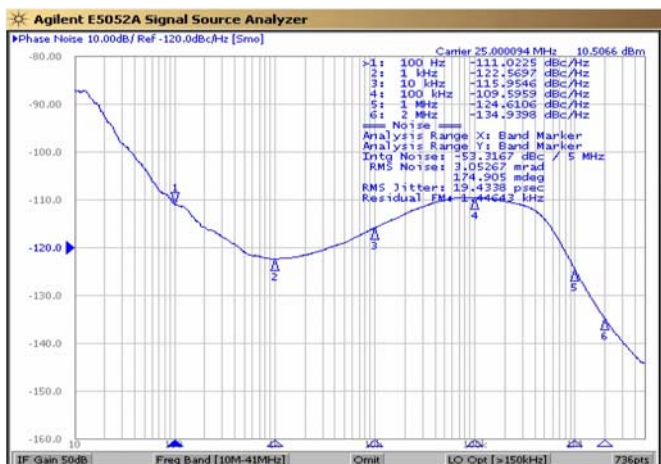

Load Circuit and Test Waveform

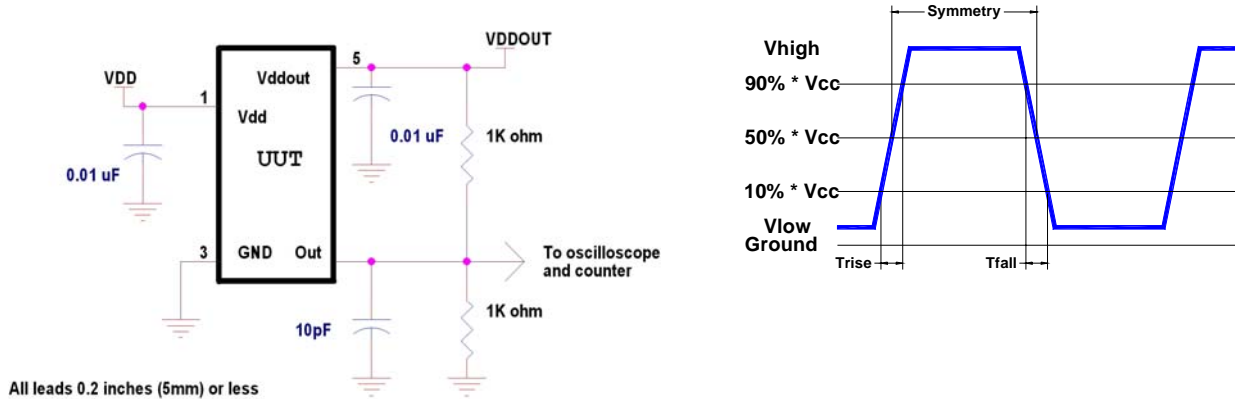

Reliability: Environmental Compliance

Parameter	Condition
Mechanical Shock	MIL-STD-883 Method 2002, Condition B
Vibration	MIL-STD-883 Method 2007, Condition A
Solderability	MIL-STD-883 Method 2003
Thermal Shock	MIL-STD-883 Method 1011, Condition A

ESD Rating

Model	Minimum Voltage	Conditions
Human Body Model	1500	MIL-STD-883 Method 3115
Charged Device Model	1000	JESD 22-C101

Mechanical:

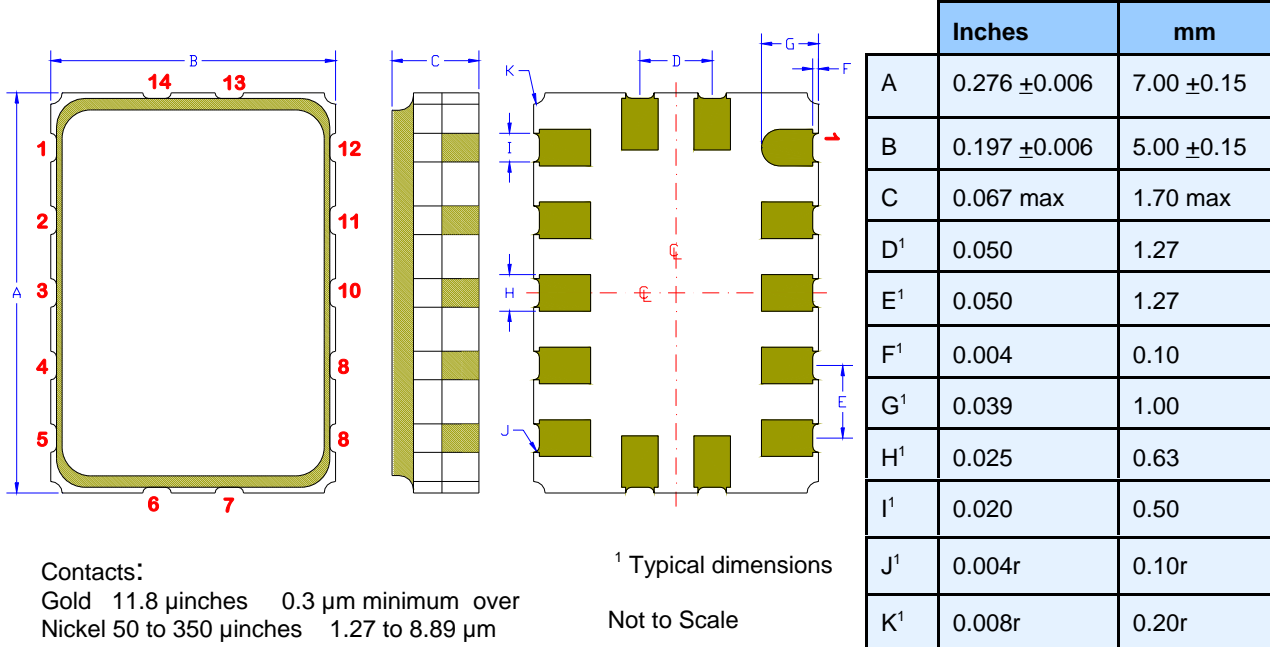

Package Labeling

Label is 1" x 2.6" (25.4mm x 66.7mm)
 Font is Courier New
 Bar code is 39-Full ASCII

Label is 1" x 2.6" (25.4mm x 66.7mm)
 Font is Arial



Pad Functions FD73xxT:

Pad	Function	Note	Output Function		
			O t h e r	S S C	S S D
1	Vsupply1	1.8V, powers internal circuitry of the oscillator. Bypass capacitor required near the package pin.			
2	Vcontrol	Frequency control input when the VCXO function is enabled			
3	Ground (GND)				
4	n.c.	No connection or connect to ground (do not connect to a signal lead)			
5	Vsupply2	1.8V, 2.5V or 3.3V supply for the output buffers. Sets CMOS output level. Bypass capacitor required near the package pin.			
6	n.c.	No connection or connect to ground (do not connect to a signal lead)			
7	n.c.	No connection or connect to ground (do not connect to a signal lead)			
8	n.c.	No connection or connect to ground (do not connect to a signal lead)			
9	Out3 (Y3)	Crystal reference frequency divider 1 and divided by 1 through 1023	X	X	X
		PLL1 frequency divider 2 and divided by 1 through 127	X	X	X
		PLL1 frequency divider 3 and divided by 1 through 127	X	X	X
10	Out2 (Y2)	Crystal reference frequency divider 1 and divided by 1 through 1023	X		
		PLL1 frequency divider 2 and divided by 1 through 127	X	X	X
11	Out1 (Y1)	Crystal reference frequency divider 1 and divided by 1 through 1023	X		
		PLL1 frequency divider 1 and divided by 1 through 1023	X	X	X
12	S2 / SCL	Serial Data Clock	S2	Input to select 1 of 8 preprogrammed functions of the outputs	
13	S1 / SDA	Serial Data	S1		
14	S0		S0		

Other Logic "0" or tri-stated (off)

SSC The output can have a spread spectrum centered about the output frequency.

SSD The output can have a spread spectrum from the output frequency downward.

All unused inputs should be pulled high.

Pad Functions FD74xxT:

Pad	Function	Note	Output Function		
			O t h e r	S S C	S S D
1	Vsupply1	1.8V, powers internal circuitry of the oscillator. Bypass capacitor required near the package pin.			
2	Vcontrol	Frequency control input when the VCXO function is enabled			
3	Ground (GND)				
4	Out4 (Y5)	PLL1 frequency divider 2 and divided by 1 through 127			
		PLL2 frequency divider 4 and divided by 1 through 127	X	X	X
		PLL2 frequency divider 5 and divided by 1 through 127			
5	Vsupply2	1.8V, 2.5V or 3.3V supply for the output buffers. Sets CMOS output level. Bypass capacitor required near the package pin.			
6	n.c.	No connection or connect to ground (do not connect to a signal lead)			
7	n.c.	No connection or connect to ground (do not connect to a signal lead)			
8	n.c.	No connection or connect to ground (do not connect to a signal lead)			
9	Out3 (Y3)	Crystal reference frequency divider 1 and divided by 1 through 1023	X	X	X
		PLL1 frequency divider 2 and divided by 1 through 127	X	X	X
		PLL1 frequency divider 3 and divided by 1 through 127	X	X	X
10	Out2 (Y2)	Crystal reference frequency divider 1 and divided by 1 through 1023	X		
		PLL1 frequency divider 2 and divided by 1 through 127	X	X	X
11	Out1 (Y1)	Crystal reference frequency divider 1 and divided by 1 through 1023	X		
		PLL1 frequency divider 1 and divided by 1 through 1023	X	X	X
12	S2 / SCL	Serial Data Clock	S2	Input to select 1 of 8 preprogrammed functions of the outputs	
13	S1 / SDA	Serial Data	S1		
14	S0		S0		

Other Logic "0" or tri-stated (off)

SSC The output can have a spread spectrum centered about the output frequency.

SSD The output can have a spread spectrum from the output frequency downward.

All unused inputs should be pulled high.

Pad Functions FD75xxT:

Pad	Function	Note	Output Function		
			O t t h e r	S S C	S S D
1	Vsupply1	1.8V, powers internal circuitry of the oscillator. Bypass capacitor required near the package pin.			
2	Vcontrol	Frequency control input when the VCXO function is enabled			
3	Ground (GND)				
4	Out4 (Y5)	PLL1 frequency divider 2 and divided by 1 through 127			
		PLL2 frequency divider 4 and divided by 1 through 127	X	X	X
		PLL2 frequency divider 5 and divided by 1 through 127			
5	Vsupply2	1.8V, 2.5V or 3.3V supply for the output buffers. Sets CMOS output level. Bypass capacitor required near the package pin.			
6	n.c.	No connection or connect to ground (do not connect to a signal lead)			
7	n.c.	No connection or connect to ground (do not connect to a signal lead)			
8	Out5 (Y7)	PLL2 frequency divider 4 and divided by 1 through 127	X	X	X
		PLL3 frequency divider 6 and divided by 1 through 127	X	X	X
		PLL3 frequency divider 7 and divided by 1 through 127	X	X	X
9	Out3 (Y3)	Crystal reference frequency divider 1 and divided by 1 through 1023	X	X	X
		PLL1 frequency divider 2 and divided by 1 through 127	X	X	X
		PLL1 frequency divider 3 and divided by 1 through 127	X	X	X
10	Out2 (Y2)	Crystal reference frequency divider 1 and divided by 1 through 1023	X		
		PLL1 frequency divider 2 and divided by 1 through 127	X	X	X
11	Out1 (Y1)	Crystal reference frequency divider 1 and divided by 1 through 1023	X		
		PLL1 frequency divider 1 and divided by 1 through 1023	X	X	X
12	S2 / SCL	Serial Data Clock	S2	Input to select 1 of 8 preprogrammed functions of the outputs	
13	S1 / SDA	Serial Data	S1		
14	S0		S0		

Other Logic "0" or tri-stated (off)

SSC The output can have a spread spectrum centered about the output frequency.

SSD The output can have a spread spectrum from the output frequency downward.

All unused inputs should be pulled high.

Pad Functions FD77xxT:

Pad	Function	Note	Output Function		
			O t h e r	S S C	S S D
1	Vsupply1	1.8V, powers internal circuitry of the oscillator. Bypass capacitor required near the package pin.			
2	Vcontrol	Frequency control input when the VCXO function is enabled			
3	Ground (GND)				
4	Out4 (Y5)	PLL1 frequency divider 2 and divided by 1 through 127			
		PLL2 frequency divider 4 and divided by 1 through 127	X	X	X
		PLL2 frequency divider 5 and divided by 1 through 127			
5	Vsupply2	1.8V, 2.5V or 3.3V supply for the output buffers. Sets CMOS output level. Bypass capacitor required near the package pin.			
6	Out6 (Y8)	PLL3 frequency divider 6 and divided by 1 through 127	X	X	X
		PLL4 frequency divider 8 and divided by 1 through 127	X	X	X
7	Out7 (Y9)	PLL3 frequency divider 6 and divided by 1 through 127	X	X	X
		PLL4 frequency divider 8 and divided by 1 through 127	X	X	X
		PLL4 frequency divider 9 and divided by 1 through 127	X	X	X
8	Out5 (Y7)	PLL2 frequency divider 4 and divided by 1 through 127	X	X	X
		PLL3 frequency divider 6 and divided by 1 through 127	X	X	X
		PLL3 frequency divider 7 and divided by 1 through 127	X	X	X
9	Out3 (Y3)	Crystal reference frequency divider 1 and divided by 1 through 1023	X	X	X
		PLL1 frequency divider 2 and divided by 1 through 127	X	X	X
		PLL1 frequency divider 3 and divided by 1 through 127	X	X	X
10	Out2 (Y2)	Crystal reference frequency divider 1 and divided by 1 through 1023	X		
		PLL1 frequency divider 2 and divided by 1 through 127	X	X	X
11	Out1 (Y1)	Crystal reference frequency divider 1 and divided by 1 through 1023	X		
		PLL1 frequency divider 1 and divided by 1 through 1023	X	X	X
12	S2 / SCL	Serial Data Clock	S2	Input to select 1 of 8 preprogrammed functions of the outputs	
13	S1 / SDA	Serial Data	S1		
14	S0		S0		

Other Logic "0" or tri-stated (off)

SSC The output can have a spread spectrum centered about the output frequency.

SSD The output can have a spread spectrum from the output frequency downward.

All unused inputs should be pulled high.

Reflow Cycle (typical for lead free-processing)



The part may be reflowed 2 times without degradation.

Tape and Reel: available for quantities of 250 to 1000 per reel, cut tape for < 250

Constant Dimensions Table 1								
Tape Size	D0	D1 Min	E1	P0	P2	S1 Min	T Max	T1 Max
8mm	1.5	1.0	1.75 ± 0.1	4.0 ± 0.1	2.0 ± 0.05	0.6	0.6	0.1
12mm		1.5			2.0 ± 0.1			
16mm		+0.1 -0.0			2.0 ± 0.1			
24mm		1.5			2.0 ± 0.1			

Variable Dimensions Table 2							
Tape Size	B1 Max	E2 Min	F	P1	T2 Max	W Max	Ao, Bo & Ko
16 mm	12.1	14.25	7.5 ± 0.1	8.0 ± 0.1	8.0	16.3	Note 1

Note 1: Embossed cavity to conform to EIA-481-B

Not to scale



REEL DIMENSIONS					
A	inches	7.0	10.0	13.0	Tape Width
	mm	177.8	254.0	330.2	
B	inches	2.50	4.00	3.75	Tape Width
	mm	63.5	101.6	95.3	
C	mm	13.0 +0.5 / -0.2			Tape Width
D	mm	16.4 +2.0 -0.0	16.4 +2.0 -0.0	16.4 +2.0 -0.0	

USER DIRECTION OF UNREELING →

Reel dimensions may vary from the above

IMPORTANT NOTICE

Pletronics Incorporated (PLE) reserves the right to make corrections, improvements, modifications and other changes to this product at any time. PLE reserves the right to discontinue any product or service without notice. Customers are responsible for obtaining the latest relevant information before placing orders and should verify that such information is current and complete. All products are sold subject to PLE's terms and conditions of sale supplied at the time of order acknowledgment.

PLE warrants performance of this product to the specifications applicable at the time of sale in accordance with PLE's limited warranty. Testing and other quality control techniques are used to the extent PLE deems necessary to support this warranty. Except where mandated by specific contractual documents, testing of all parameters of each product is not necessarily performed.

PLE assumes no liability for application assistance or customer product design. Customers are responsible for their products and applications using PLE components. To minimize the risks associated with the customer products and applications, customers should provide adequate design and operating safeguards.

PLE products are not designed, intended, authorized or warranted to be suitable for use in life support applications, devices or systems or other critical applications that may involve potential risks of death, personal injury or severe property or environmental damage. Inclusion of PLE products in such applications is understood to be fully at the risk of the customer. Use of PLE products in such applications requires the written approval of an appropriate PLE officer. Questions concerning potential risk applications should be directed to PLE.

PLE does not warrant or represent that any license, either express or implied, is granted under any PLE patent right, copyright, artwork or other intellectual property right relating to any combination, machine or process which PLE product or services are used. Information published by PLE regarding third-party products or services does not constitute a license from PLE to use such products or services or a warranty or endorsement thereof. Use of such information may require a license from a third party under the patents or other intellectual property of the third party, or a license from PLE under the patents or other intellectual property of PLE.

Reproduction of information in PLE data sheets or web site is permissible only if the reproduction is without alteration and is accompanied by associated warranties, conditions, limitations and notices. Reproduction of this information with alteration is an unfair and deceptive business practice. PLE is not responsible or liable for such altered documents.

Resale of PLE products or services with statements different from or beyond the parameters stated by PLE for that product or service voids all express and implied warranties for the associated PLE product or service and is an unfair or deceptive business practice. PLE is not responsible for any such statements.

Contacting Pletronics Inc.

Pletronics Inc.
19013 36th Ave. West
Lynnwood, WA 98036-5761 USA

Tel: 425-776-1880
Fax: 425-776-2760
E-mail: ple-sales@pletronics.com
URL: www.pletronics.com

Copyright © 2007, 2008 Pletronics Inc.