

## CV-HB-201: 2-Amp H-Bridge

The CV-HB 201 single channel H-bridge enables smooth control of the speed and direction of a DC motor using 3 logic-level inputs. Low on-resistance MOSFETs allow for high efficiency control with minimal power loss. Designed to mount onto a proto-board, the controller also has terminal blocks for quick connection to the motor and power supply.

### Features:

- 5 V to 28 V Operation
- High efficiency MOSFET design for cool operation
- Supports Simple PWM mode ( 2 quadrant forward/reverse/coast/brake)
- Supports 4 quadrant control (locked anti-phase)
- Power and PWM LED's for visual indication of operation
- Integrated 5 V regulator for powering external logic

### Ample Protection:

- Over-current automatic shutoff
- Short-circuit protection via resettable fuse
- Over-temperature shutoff
- Under-voltage lockout
- Reverse-polarity protected

### Versatile Connections:

- 8 pin SIP header for vertical proto-board mounting
- Terminal blocks for power and motor connections
- PCB Holes for direct-wire solder connections

**Absolute Maximum Ratings:**

Parameter	Max	Units
DC Input Voltage	28	V
Continuous Output Current	2	A
Momentary Output Current, T=0.5 second	3	A
5 V Output, Maximum Current	100	mA
Logic Level Input	7	V

*Warning – operating at or above the absolute maximum ratings may damage the controller and/or the equipment under control.*

**Electrical Characteristics:**

( Valid for 5 – 28 V input, -40 °C to 100 °C )

**Power Supply:**

Parameter	Min	Typical	Max	Units
Power Supply Voltage (5V output regulated)	7	--	28	V
Power Supply Voltage (5V output unregulated)	5	--	28	V
Continuous Output Current	--	--	2	A
Quiescent Current Drain (Motor Output Current = 0)	--	--	45	mA
Temperature	-40	25	+85	°C

**Logic Inputs:**

Parameter	Min	Typical	Max	Units
Low Level ( IN1, IN2, EN )	0	--	1.4	V
High Level ( IN1, IN2, EN )	3.4	--	5	V

**Power Outputs: (M+, M-)**

Parameter	Min	Typical	Max	Units
Switch On Resistance	--	--	300	mΩ
Leakage Current (output stage switched off)	--	--	100	μA
Free-Wheeling Diode Forward Voltage ( $I_{out} = 3A$ )	--	--	2	V
Free-Wheeling Diode Reverse Recovery Time	100	--	--	nS
Switch-Off Temperature (Over-Heat Protection)	160	--	190	°C

**Timing:**

Parameter	Min	Typical	Max	Units
PWM Frequency	--	--	10	kHz
Output On Delay (IN1 → M+ or IN2 → M-)	--	--	15	μS
Output Off Delay (IN1 → M+ or IN2 → M-)	--	--	15	μS
Output Switching Time (M+.H → M+.L or M-.L → M-.H)	2	--	5	μS

**Onboard 5V Regulator:**

Parameter	Min	Typical	Max	Units
Output Current	0	--	100	mA

**Pin-out:**

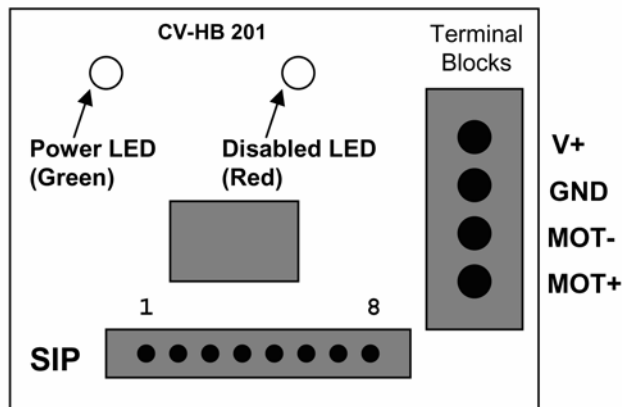

**8 pin SIP header pins (left to right):**

Pin Number	Pin Label	Function	Notes
1	IN1	Switch Input 1	See truth table
2	IN2	Switch Input 2	See truth table
3	EN	Switch Enable	See truth table
4	VCC	5 V output from onboard regulator	100 mA Max.
5	V+	Positive terminal from power supply	Also on terminal blocks
6	GND	Negative terminal (ground) from power supply	Also on terminal blocks
7	MOT+	Output to motor	Also on terminal blocks
8	MOT-	Output to motor	Also on terminal blocks

**Device Truth Table:**

Modes	Device State	Input Conditions			Outputs		
		IN1	IN2	EN	MOT+	MOT-	DIS LED
Typical	1 – Forward	H	L	H	H	L	OFF
	2 – Reverse	L	H	H	L	H	OFF
	3 – Free-Wheeling Low (Brake)	L	L	H	L	L	OFF
	4 – Free-Wheeling High (Brake)	H	H	H	H	H	OFF
	5 – Disable (Coast)	X	X	L	Z	Z	ON
Disconnected Pins	6 – IN1 Disconnected	Z	X	H	H	X	OFF
	7 – IN2 Disconnected	X	Z	H	X	H	OFF
	8 – EN Disconnected	X	X	Z	Z	Z	ON
Protection Active	9 – Under Voltage Lockout	X	X	X	Z	Z	ON
	10 – Over Temperature	X	X	X	Z	Z	ON
	11 – Over Current	X	X	X	Z	Z	ON

**Typical Connections:**

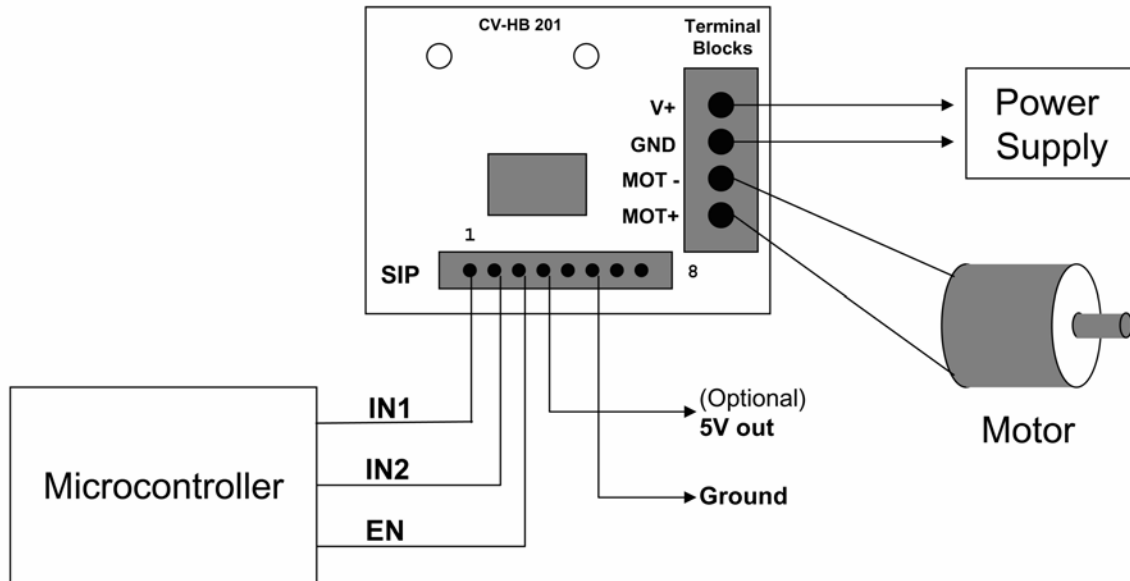

**Installation:**

The CV-HB 201 can be installed onto a proto-board using the 8-pin SIP connector. All the necessary connections to the board can be done through this connector alone. Terminal blocks are provided to facilitate the use of larger gauge wire and direct connection to the power supply and motor.

For permanent installations, wires may be soldered directly into the eight holes above the SIP header. Four mounting holes are provided at the corners of the board

**Operation:**

The three inputs, IN1, IN2 and EN are used to control the operation of the H-bridge.

IN1 and IN2 effectively control the direction of the motor. If both IN1 and IN2 are at the same logic level, the controller is in Braking mode.

EN1 is typically switched on and off in a PWM fashion to control the average driving power to the motor in either direction. When in braking mode, it controls the average braking power of the motor. When the EN pin is held low (disabled), the motor coasts freely.

Please see the truth table for more detail.

The “DIS” LED (Red LED) lights up when the controller is in disabled mode, such as when the EN pin is held low, or when any of the protection circuitry is active, such as over current, or under voltage. When using PWM on the EN pin, the LED will glow inversely proportional to the pulse width. At 100% pulse width, the LED is extinguished. At 0% pulse width, the LED is fully lit.

### **Protection Modes:**

#### **Over-current:**

When the instantaneous current is beyond the device limits, the output driver will be pulsed to effectively limit the current. This situation can arise when a motor with a very large startup current is first turned on at full power. As the motor spins up to speed, the current demand will decrease, and the current limiting action will cease. When current limiting is active, the DIS LED will be lit, its brightness proportional to the degree of current limiting applied.

#### **Under-voltage:**

Driving the H-Bridge using N-channel MOSFETs requires a gate voltage approximately 10 volts above the supply voltage. To accomplish this, the controller features an integrated charge pump to boost the gate voltage to the high-side MOSFETs. When the supply voltage to the controller is too low to sustain proper charge pump action, the controller will go into shutdown mode, disabling all motor outputs, and illuminating the DIS LED. When the voltage rises above the minimum level, the controller will be re-enabled automatically.

#### **Over-temperature:**

During normal operation within the maximum limits of the controller, the controller should not go into over-temperature shut down. In the event that the internal die temperature reaches approximately 160 degrees C, the controller will automatically shut down to prevent damage.

#### **Fuse Activated:**

A 4-amp resettable fuse is integrated into the controller. If the fuse activates, simply remove power, allow a minute for the fuse to reset, check all wiring, and re-apply power.

#### **Reverse Polarity:**

An on-board diode prevents any damage should the board be inadvertently connected backwards to the power supply.

### **On-board 5 V regulator**

The 5 V output can be used to power a microcontroller, logic or other circuitry. For proper regulation, the voltage supplied to the H-Bridge must be at least 7 volts. At operating voltages below 7 volts, 5 volt regulation is not guaranteed.

In general, it is not recommended to power noise-sensitive circuitry from this 5 V output. Since the regulator shares the same power supply as the motor, electrical noise from the motor will feed back into the power supply. When powering logic circuits and microcontrollers, be sure to install a 0.1  $\mu\text{F}$  ceramic capacitor at each logic chip's VDD and GND pins, as close to the chip as possible. Follow recommended grounding practices to reduce the possibility of interference.

### **Design Considerations:**

Ensure that the wires carrying the load current are adequately sized. The controller should be located as close to the motor as possible. If the wires between the power source and the controller need to be greater than 1 foot long, then add a 1000  $\mu\text{F}$  capacitor rated for at least twice the supply voltage across the power input terminals of the controller.

PWM controllers switch currents at high frequencies to vary the average power to the load. This switching can cause undesirable RF interference. To minimize such interference, it is recommended to twist the input V+ and Ground wire pair as well as the MOT+ and MOT- wire pair. In addition, installation of a small capacitor from each of the two motor terminals to the metal case may reduce noise emission.

Always turn off the power supply before making any changes to the wiring.

Ensure that the controller has adequate air flow for proper cooling. If operating for extended periods of time in high temperature environments at maximum capacity, a cooling fan may be necessary.

---

**30-Day Limited Warranty:**

Subject to the provisions described below, CRITICAL VELOCITY ENTERPRISES, LLC (“Critical Velocity”) warrants this product to be free from defects in material and workmanship for thirty (30) days from the date of purchase by the original consumer. If any part is found to be defective during the warranted period, it will be repaired or replaced with the same or functionally equivalent product by Critical Velocity, at its discretion, free of charge provided you: (1) return the failed product to Critical Velocity with shipping prepaid, and (2) provide Critical Velocity with proof of the original date of purchase. Repaired or replacement products will be returned to you with shipping charges prepaid.

Replacement products may be refurbished or contain refurbished materials. If Critical Velocity, by its sole determination, is unable to repair or replace the defective product, it will refund the purchase price of the product. This warranty does not apply if, in the judgment of Critical Velocity, the product fails due to damage from shipment, handling, storage, accident, abuse or misuse, or if it has been used or maintained in a manner not conforming to product manual instructions or has been modified in any way. Repair by anyone other than Critical Velocity will void this warranty. The maximum liability of Critical Velocity under this warranty is limited to the purchase price of the product covered by the warranty.

Except as specifically provided in this agreement or as required by law, the warranties and remedies stated above are exclusive and in lieu of all others, oral or written, express or implied. Any and all other warranties, including implied warranties of merchantability, fitness for a particular purpose and noninfringement of third party rights are expressly excluded. Critical Velocity shall not under any circumstances be liable for any special, incidental, indirect or consequential damages, including without limitation, damages resulting from use or malfunction of the products, loss of profits or revenues or costs of replacement goods, even if Critical Velocity is informed in advance of the possibility of such damages.

**LIFE SUPPORT POLICY:**

Critical Velocity’s products are not authorized for use as critical components in life support devices or systems. As used herein:

1. Life support devices or systems are devices or systems which, (a) are intended for surgical implant into the body, or (b) support or sustain life, and (c) whose failure to perform when properly used in accordance with instructions for use provided in the labeling, can be reasonably expected to result in a significant injury of the user.
2. A critical component in any component of a life support device or system whose failure to perform can be reasonably expected to cause the failure of the life support device or system, or to affect its safety or effectiveness.