

Silicon PNP Power Transistors

2SB761 2SB761A

DESCRIPTION

- With TO-220C package
- Complement to type 2SD856/856A
- Low collector saturation voltage

APPLICATIONS

- For audio frequency power amplifier applications

PINNING

PIN	DESCRIPTION
1	Emitter
2	Collector;connected to mounting base
3	Base

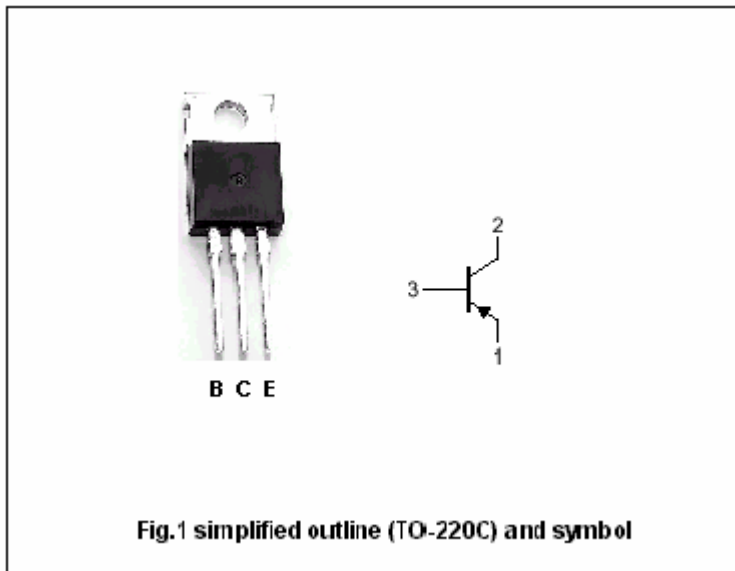

Absolute maximum ratings(Tc=25)

SYMBOL	PARAMETER	CONDITIONS	VALUE	UNIT
V _{CBO}	Collector-base voltage	2SB761	-60	V
		2SB761A	-80	
V _{CEO}	Collector-emitter voltage	2SB761	-60	V
		2SB761A	-80	
V _{EBO}	Emitter-base voltage	Open collector	-5	V
I _C	Collector current		-3	A
I _{CM}	Collector current-peak		-5	A
P _C	Collector power dissipation	T _C =25	35	W
T _j	Junction temperature		150	
T _{stg}	Storage temperature		-55~150	

Silicon PNP Power Transistors

2SB761 2SB761A

CHARACTERISTICS

T_j=25 unless otherwise specified

SYMBOL	PARAMETER		CONDITIONS	MIN	TYP.	MAX	UNIT
V _{CEO}	Collector-emitter breakdown voltage	2SB761	I _C =-30mA; I _B =0	-60			V
		2SB761A		-80			
V _{CEsat}	Collector-emitter saturation voltage		I _C =-3 A; I _B =-0.375 A			-1.2	V
V _{BE}	Base-emitter on voltage		I _C =-3A; V _{CE} =-4V			-1.8	V
I _{CES}	Collector cut-off current	2SB761	V _{CE} =-60V; V _{BE} =0			-200	μ A
		2SB761A	V _{CE} =-80V; V _{BE} =0				
I _{CEO}	Collector cut-off current		V _{CE} =-60V; I _B =0			-300	μ A
I _{EBO}	Emitter cut-off current		V _{EB} =-5V; I _C =0			-1	mA
h _{FE-1}	DC current gain		I _C =-1A; V _{CE} =-4V	40		250	
h _{FE-2}	DC current gain		I _C =-3A; V _{CE} =-4V	10			

Switching times

t _{on}	Turn-on time	I _C =-1A; I _{B1} =-I _{B2} =-0.1 A		0.5		μ s
t _{off}	Turn-off time			2.0		μ s

◆ h_{FE-1} classifications

R	Q	P
40-90	70-150	120-250

Silicon PNP Power Transistors

2SB761 2SB761A

PACKAGE OUTLINE

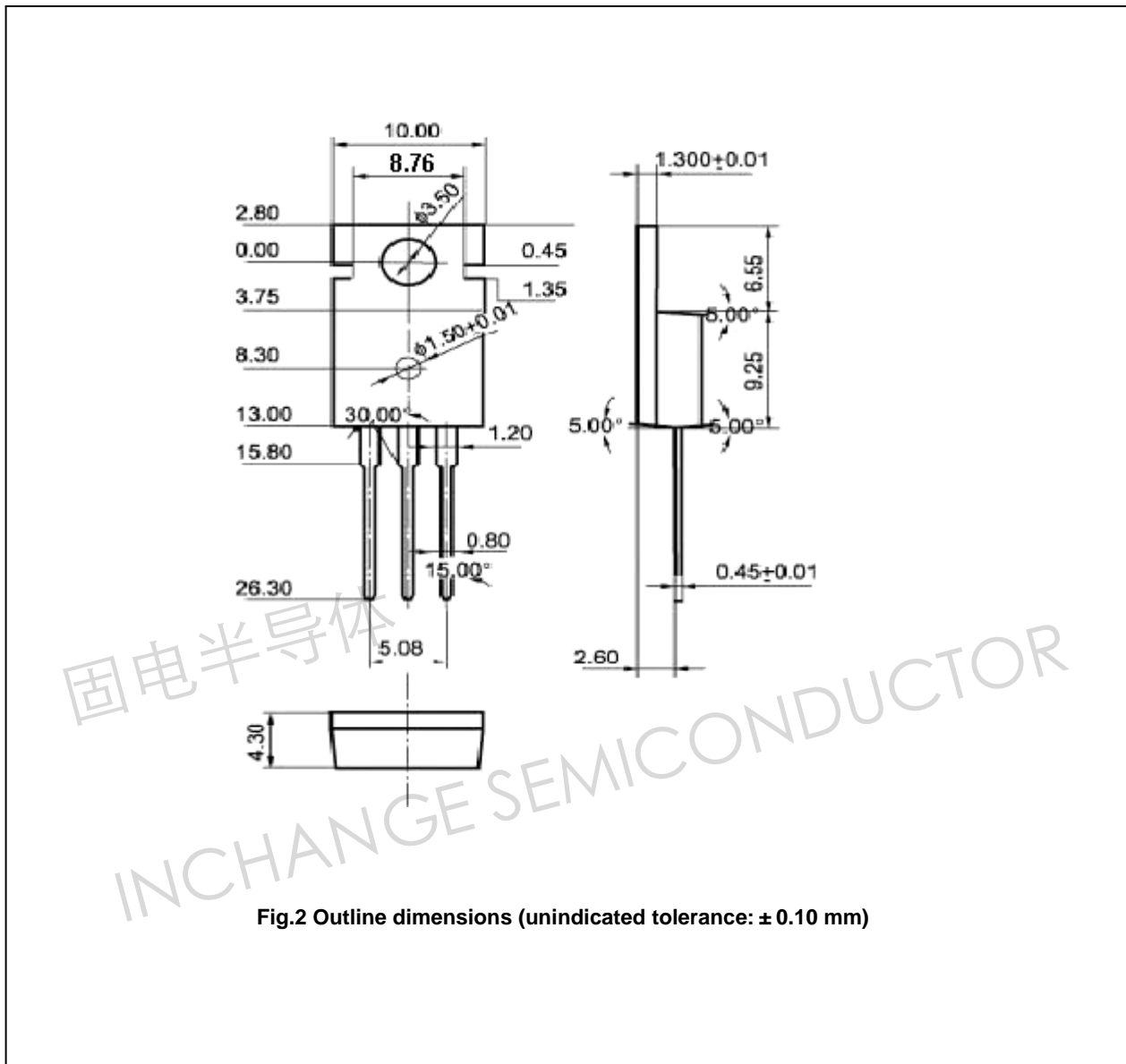

Fig.2 Outline dimensions (unindicated tolerance: ± 0.10 mm)