

SR1620 THRU SR1660



16.0 AMP SCHOTTKY BARRIER RECTIFIERS



FEATURES

- * Low forward voltage drop
- * High current capability
- * High reliability
- * High surge current capability
- * Epitaxial construction

MECHANICAL DATA

- * Case: Molded plastic
- * Epoxy: UL 94V-0 rate flame retardant
- * Lead: Lead solderable per MIL-STD-202, method 208 guaranteed
- * Polarity: As Marked
- * Mounting position: Any
- * Weight: 2.24 grams

VOLTAGE RANGE

20 to 60 Volts

CURRENT

16.0 Amperes

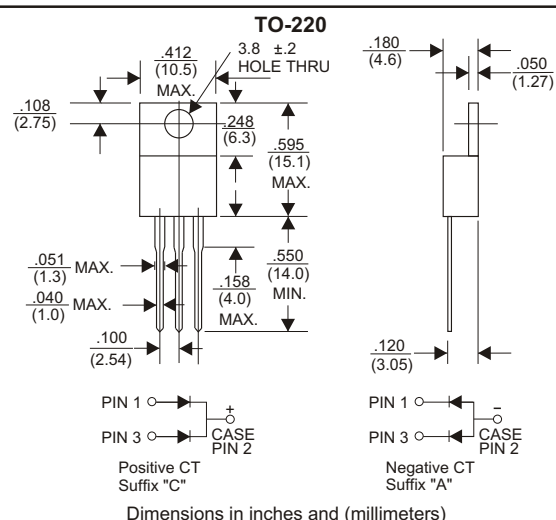

MAXIMUM RATINGS AND ELECTRICAL CHARACTERISTICS

Rating 25°C ambient temperature unless otherwise specified.
Single phase half wave, 60Hz, resistive or inductive load.
For capacitive load, derate current by 20%.

TYPE NUMBER	SR1620	SR1630	SR1635	SR1640	SR1645	SR1650	SR1660	UNITS
Maximum Recurrent Peak Reverse Voltage	20	30	35	40	45	50	60	V
Maximum RMS Voltage	14	21	24	28	31	35	42	V
Maximum DC Blocking Voltage	20	30	35	40	45	50	60	V
Maximum Average Forward Rectified Current								
See Fig. 1	16							A
Peak Forward Surge Current, 8.3 ms single half sine-wave superimposed on rated load (JEDEC method)	150							A
Maximum Instantaneous Forward Voltage per Leg at 8.0A	0.65					0.75		V
Maximum DC Reverse Current Ta=25°C	10							mA
at Rated DC Blocking Voltage Ta=100°C	100							mA
Typical Junction Capacitance (Note1)	700					460		pF
Typical Thermal Resistance R _{JC} (Note 2)	3.0							°C/W
Operating Temperature Range T _J	-65 — +125					-65 — +150		°C
Storage Temperature Range T _{STG}	-65 — +150							°C

NOTES:

1. Measured at 1MHz and applied reverse voltage of 4.0V D.C.
2. Thermal Resistance Junction to Case.

RATING AND CHARACTERISTIC CURVES (SR1620 THRU SR1660)

FIG.1-TYPICAL FORWARD CURRENT DERATING CURVE

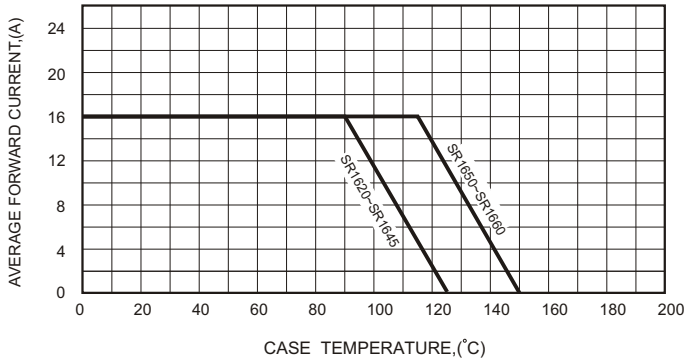

FIG.2-TYPICAL FORWARD CHARACTERISTICS

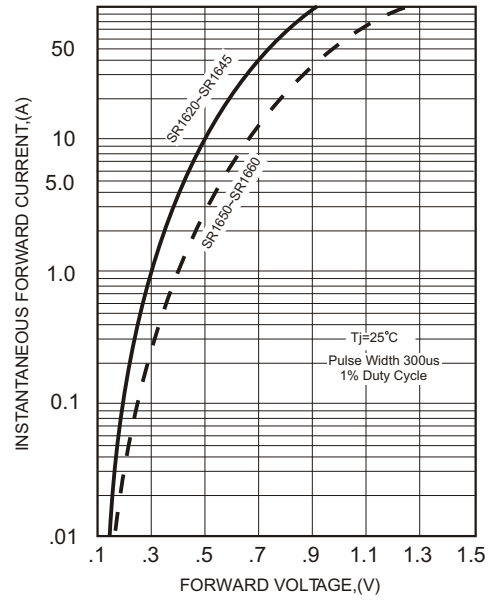

FIG.3-MAXIMUM NON-REPETITIVE FORWARD SURGE CURRENT

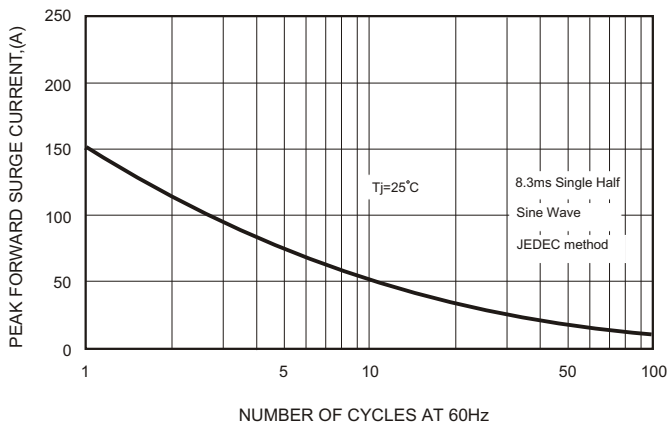

FIG.4-TYPICAL JUNCTION CAPACITANCE

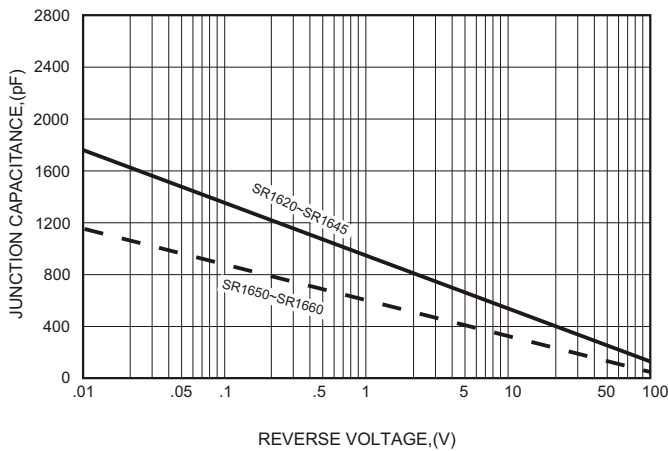

FIG.5 - TYPICAL REVERSE CHARACTERISTICS

