

Integrated Silicon Pressure Sensor On-Chip Signal Conditioned, Temperature Compensated, and Calibrated

The MPX5100 series piezoresistive transducer is a state-of-the-art monolithic silicon pressure sensor designed for a wide range of applications, but particularly those employing a microcontroller or microprocessor with A/D inputs. This patented, single element transducer combines advanced micromachining techniques, thin-film metallization, and bipolar processing to provide an accurate, high level analog output signal that is proportional to the applied pressure.

Features

- 2.5% Maximum Error over 0° to 85°C
- Ideally suited for Microprocessor or Microcontroller-Based Systems
- Patented Silicon Shear Stress Strain Gauge
- Available in Absolute, Differential and Gauge Configurations
- Durable Epoxy Unibody Element
- Easy-to-Use Chip Carrier Option

Typical Applications

- Patient Monitoring
- Process Control
- Pump/Motor Control
- Pressure Switching

ORDERING INFORMATION

Device Type	Options	Case No.	MPX Series Order Number	Device Marking
UNIBODY PACKAGE (MPX5100 SERIES)				
Basic Elements	Absolute	867	MPX5100A	MPX5100A
	Differential	867	MPX5100D	MPX5100D
Ported Elements	Differential Dual Ports	867C	MPX5100DP	MPX5100DP
	Absolute, Single Port	867B	MPX5100AP	MPX5100AP
	Gauge, Single Port	867B	MPX5100GP	MPX5100GP
	Gauge, Axial PC Mount	867F	MPX5100GSX	MPX5100D
	Gauge, Axial Port, SMT	482A	MPXV5100GC6U	MPXV5100G
	Gauge, Axial Port, DIP	482C	MPXV5100GC7U	MPXV5100G
	Gauge, Dual Port, SMT	1351	MPXV5100DP	MPXV5100
Gauge, Side Port, SMT	1369	MPXV5100GP	MPXV5100G	

MPX5100/MPXV5100 SERIES

INTEGRATED PRESSURE SENSOR
 0 to 100 kpa (0 to 14.5 psi)
 15 to 115 kPa
 (2.2 to 16.7 psi)
 0.2 to 4.7 V Output

SMALL OUTLINE PACKAGES

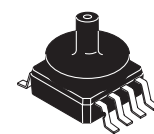

MPXV5100GC6U
 CASE 482A-01

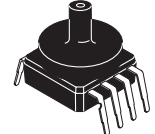

MPXV5100GC7U
 CASE 482C-03

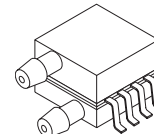

MPXV5100DP
 CASE 1351-01

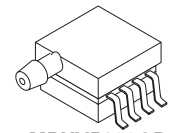

MPXV5100GP
 CASE 1369-01

PIN NUMBER⁽¹⁾

1	N/C	5	N/C
2	V _S	6	N/C
3	GND	7	N/C
4	V _{OUT}	8	N/C

1. Pins 1, 5, 6, 7, and 8 are internal device connections. Do not connect to external circuitry or ground. Pin1 is noted by the notch in the lead.

PIN NUMBER⁽¹⁾

1	V _{OUT}	4	N/C
2	GND	5	N/C
3	V _S	6	N/C

1. Pins 4, 5, and 6 are internal device connections. Do not connect to external circuitry or ground. Pin 1 is noted by the notch in the lead.

UNIBODY PACKAGES

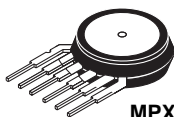

MPX5100A/D
 CASE 867-08

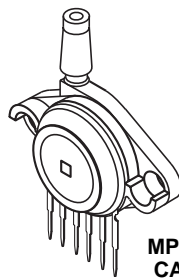

MPX5100AP/GP
 CASE 867B-04

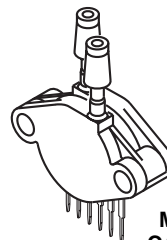

MPX5100DP
 CASE 867C-05

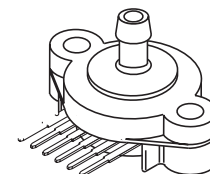

MPX5100GSX
 CASE 867F-03

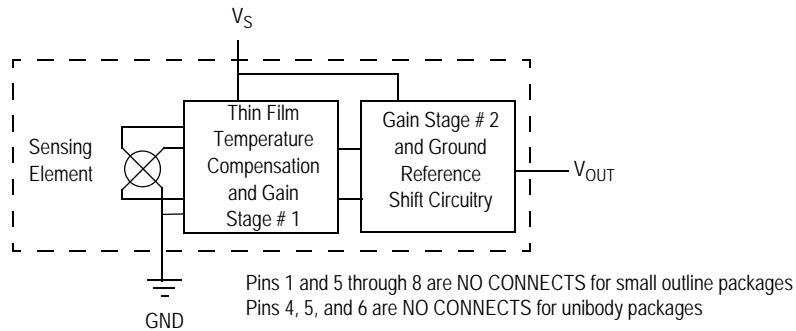

Figure 1. Fully Integrated Pressure Sensor Schematic

TABLE 1. Maximum Ratings⁽¹⁾

Rating	Symbol	Value	Unit
Maximum Pressure (P1 > P2)	P _{MAX}	400	kPa
Storage Temperature	T _{STG}	-40° to +125°C	°C
Operating Temperature	T _A	-40° to +125°C	°C

1. Exposure beyond the specified limits may cause permanent damage or degradation to the device.

TABLE 2. Operating Characteristics (V_S = 5.0 V_{DC}, T_A = 25°C unless otherwise noted, P1 > P2. Decoupling circuit shown in Figure 4 required to meet electrical specifications.)

Characteristic	Symbol	Min	Typ	Max	Unit
Pressure Range ⁽¹⁾ Gauge, Differential: MPX5100D/MPX5100G/MPXV5100G Absolute: MPX5100A	P _{OP}	0 15	— —	100 115	kPa
Supply Voltage ⁽²⁾	V _S	4.75	5.0	5.25	V _{DC}
Supply Current	I _O	—	7.0	10	mAdc
Minimum Pressure Offset ⁽³⁾ @ V _S = 5.0 V	V _{OFF}	0.088	0.20	0.313	V _{DC}
Full Scale Output ⁽⁴⁾ @ V _S = 5.0 V	V _{FSO}	4.587	4.700	4.813	V _{DC}
Full Scale Span ⁽⁵⁾ @ V _S = 5.0 V	V _{FSS}	—	4.500	—	V _{DC}
Accuracy ⁽⁶⁾	—	—	—	±2.5	%V _{FSS}
Sensitivity	V/P	—	45	—	mV/kPa
Response Time ⁽⁷⁾	t _R	—	1.0	—	ms
Output Source Current at Full Scale Output	I _{O+}	—	0.1	—	mAdc
Warm-Up Time ⁽⁸⁾	—	—	20	—	ms
Offset Stability ⁽⁹⁾	—	—	±0.5	—	%V _{FSS}

1. 1 kPa (kiloPascal) equals 0.145 psi.
2. Device is ratiometric within this specified excitation range.
3. Offset (V_{OFF}) is defined as the output voltage at the minimum rated pressure.
4. Full Scale Output (V_{FSO}) is defined as the output voltage at the maximum or full rated pressure.
5. Full Scale Span (V_{FSS}) is defined as the algebraic difference between the output voltage at full rated pressure and the output voltage at the minimum rated pressure.
6. Accuracy (error budget) consists of the following:
 - Linearity: Output deviation from a straight line relationship with pressure over the specified pressure range.
 - Temperature Hysteresis: Output deviation at any temperature within the operating temperature range, after the temperature is cycled to and from the minimum or maximum operating temperature points, with zero differential pressure applied.
 - Pressure Hysteresis: Output deviation at any pressure within the specified range, when this pressure is cycled to and from minimum or maximum rated pressure at 25°C.
 - TcSpan: Output deviation over the temperature range of 0° to 85°C, relative to 25°C.
 - TcOffset: Output deviation with minimum pressure applied over the temperature range of 0° to 85°C, relative to 25°C.
 - Variation from Nominal: The variation from nominal values, for Offset or Full Scale Span, as a percent of V_{FSS} at 25°C.

7. Response Time is defined as the time for the incremental change in the output to go from 10% to 90% of its final value when subjected to a specified step change in pressure.
8. Warm-Up Time is defined as the time required for the product to meet the specified output voltage after the Pressure has been stabilized.
9. Offset Stability is the product's output deviation when subjected to 1000 hours of Pulsed Pressure, Temperature Cycling with Bias Test.

ON-CHIP TEMPERATURE COMPENSATION, CALIBRATION AND SIGNAL CONDITIONING

Figure 2 shows the sensor output signal relative to pressure input. Typical, minimum, and maximum output curves are shown for operation over a temperature range of 0°C to 85°C using the decoupling circuit shown in Figure 4. The output will saturate outside of the specified pressure range.

Figure 3 illustrates both the Differential/Gauge and the Absolute Sensing Chip in the basic chip carrier (Case 867). A fluorosilicone gel isolates the die surface and wire bonds from the environment, while allowing the pressure signal to be transmitted to the sensor diaphragm.

The MPX5100 series pressure sensor operating characteristics, and internal reliability and qualification tests are based on use of dry air as the pressure media. Media, other than dry air, may have adverse effects on sensor performance and long-term reliability. Contact the factory for information regarding media compatibility in your application.

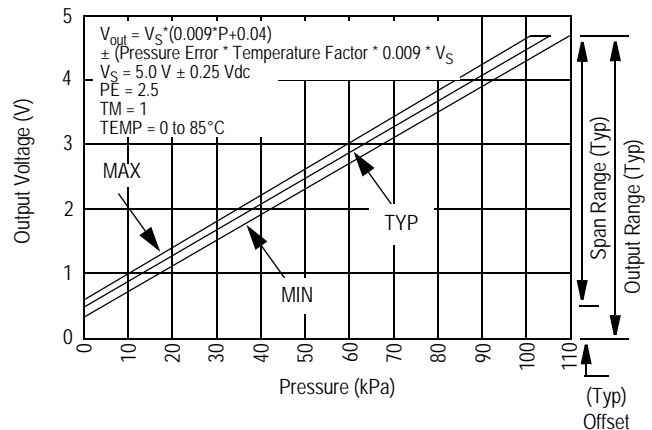

Figure 2. Output Vs. Pressure Differential

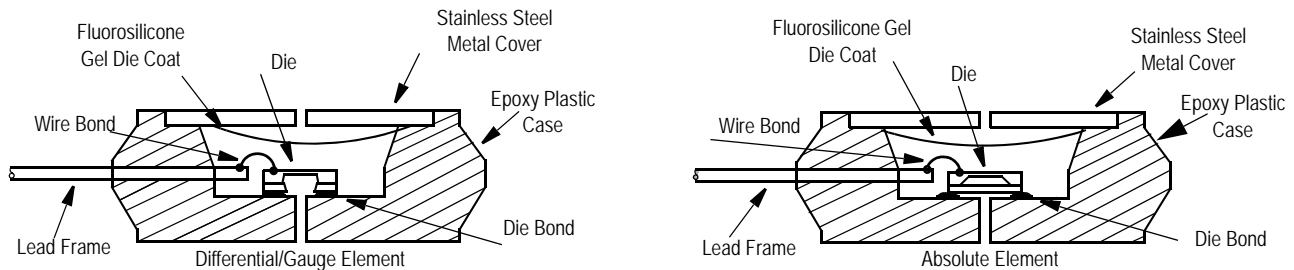

Figure 3. Cross Sectional Diagrams (Not to Scale)

Figure 4 shows the recommended decoupling circuit for interfacing the output of the integrated sensor to the A/D input

of a microprocessor or microcontroller. Proper decoupling of the power supply is recommended.

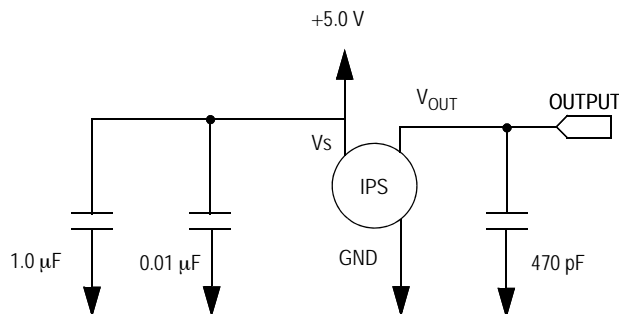

Figure 4. Recommended Power Supply Decoupling and Output Filtering
(For additional output filtering, please refer to Application Note AN1646.)

Transfer Function (MPX5100D, MPX5100G, MPXV5100G)

Nominal Transfer Value: $V_{OUT} = V_S (P \times 0.009 + 0.04)$
 $\pm (\text{Pressure Error} \times \text{Temp. Mult.} \times 0.009 \times V_S)$
 $V_S = 5.0 \text{ V} \pm 5\% \text{ P kPa}$

Temperature Error Multiplier

MPX5100D/MPX5100G/MPXV5100G Series

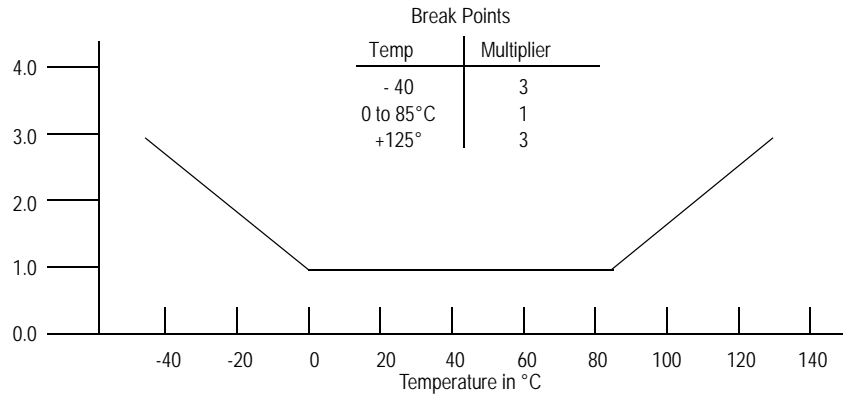

Note: The Temperature Multiplier is a linear response from 0° to -40°C and from 85° to 125°C.

Pressure Error Band

MPX5100D/MPX5100G/MPXV5100G Series

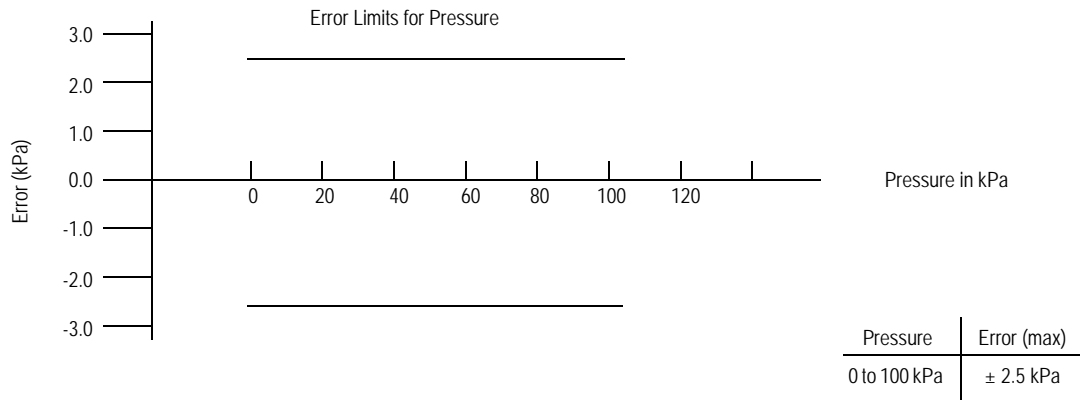

Transfer Function (MPX5100A)

Nominal Transfer Value: $V_{OUT} = V_S (P \times 0.009 + 0.095)$
 $\pm (\text{Pressure Error} \times \text{Temp. Mult.} \times 0.009 \times V_S)$
 $V_S = 5.0 \text{ V } \pm 5\% \text{ P kPa}$

Temperature Error Multiplier

MPX5100A Series

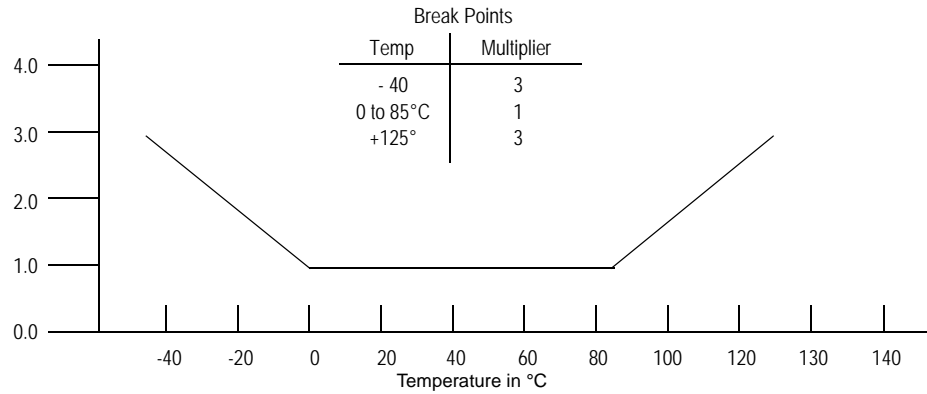

Note: The Temperature Multiplier is a linear response from 0° to -40°C and from 85° to 125°C.

Pressure Error Band

MPX5100A Series

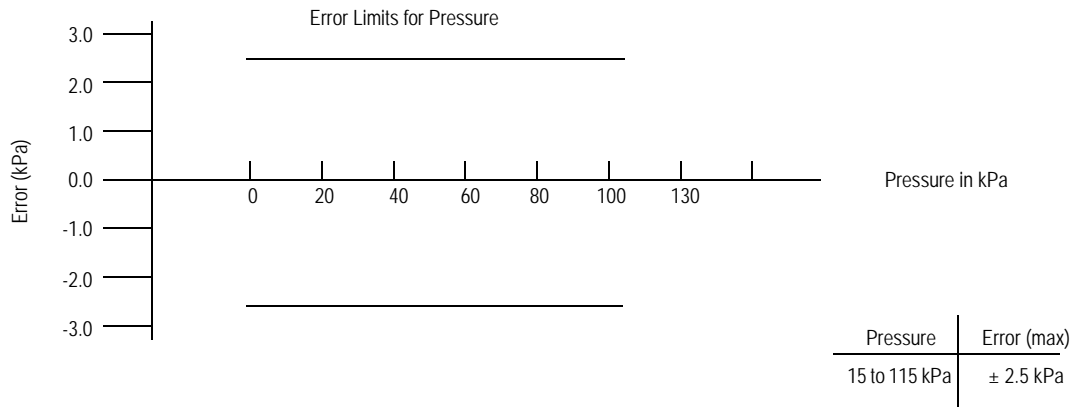

PRESSURE (P1)/VACUUM (P2) SIDE IDENTIFICATION TABLE

Freescale designates the two sides of the pressure sensor as the Pressure (P1) side and the Vacuum (P2) side. The Pressure (P1) side is the side containing fluoro silicone gel which protects the die from harsh media. The MPX pressure

sensor is designed to operate with positive differential pressure applied, $P1 > P2$.

The Pressure (P1) side may be identified by using [Table 3](#) below.

TABLE 3. PRESSURE (P1)/VACUUM (P2) SIDE IDENTIFICATION TABLE

Part Number	Case Type	Pressure (P1) Side Identifier
MPX5100A, MPX5100D	867	Stainless Steel Cap
MPX5100DP	867C	Side with Part Marking
MPX5100AP, MPX5100GP	867B	Side with Port Attached
MPX5100GSX	867F	Side with Port Attached
MPXV5100GC6U	482A	Side with Port Attached
MPXV5100GC7U	482C	Side with Port Attached
MPXV5100DP	1351	Side with Part Marking
MPXV5100GP	1369	Side with Port Attached

INFORMATION FOR USING THE SMALL OUTLINE PACKAGE

MINIMUM RECOMMENDED FOOTPRINT FOR SURFACE MOUNTED APPLICATIONS

Surface mount board layout is a critical portion of the total design. The footprint for the surface mount packages must be the correct size to ensure proper solder connection interface between the board and the package. With the correct

footprint, the packages will self align when subjected to a solder reflow process. It is always recommended to design boards with a solder mask layer to avoid bridging and shorting between solder

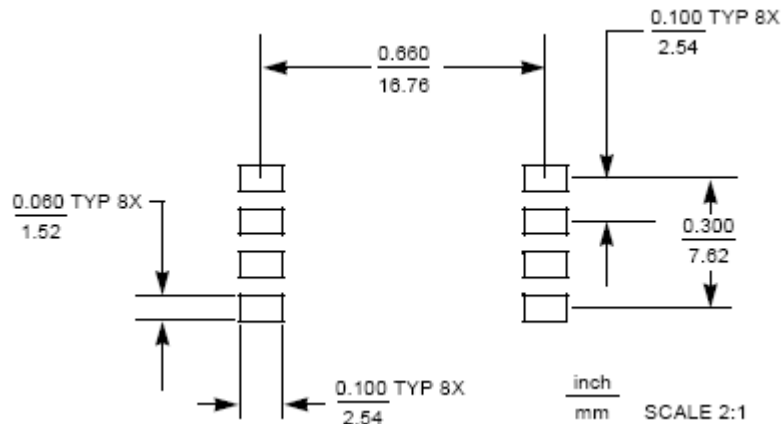
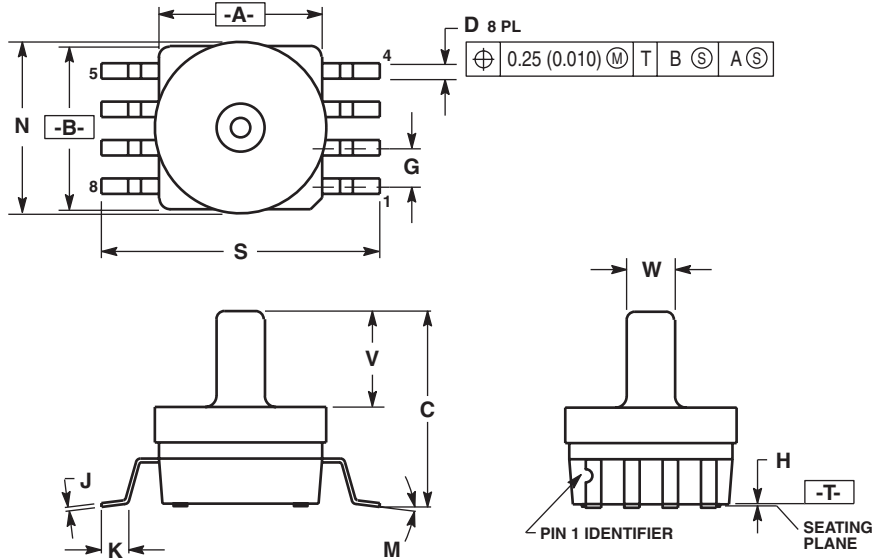

Figure 5. Small Outline Package Footprint

PACKAGE DIMENSIONS



- NOTES:
1. DIMENSIONING AND TOLERANCING PER ANSI Y14.5M, 1982.
 2. CONTROLLING DIMENSION: INCH.
 3. DIMENSION A AND B DO NOT INCLUDE MOLD PROTRUSION.
 4. MAXIMUM MOLD PROTRUSION 0.15 (0.006).
 5. ALL VERTICAL SURFACES 5° TYPICAL DRAFT.

DIM	INCHES		MILLIMETERS	
	MIN	MAX	MIN	MAX
A	0.415	0.425	10.54	10.79
B	0.415	0.425	10.54	10.79
C	0.500	0.520	12.70	13.21
D	0.038	0.042	0.96	1.07
G	0.100 BSC		2.54 BSC	
H	0.002	0.010	0.05	0.25
J	0.009	0.011	0.23	0.28
K	0.061	0.071	1.55	1.80
M	0°	7°	0°	7°
N	0.444	0.448	11.28	11.38
S	0.709	0.725	18.01	18.41
V	0.245	0.255	6.22	6.48
W	0.115	0.125	2.92	3.17

CASE 482A-01 ISSUE A SMALL OUTLINE PACKAGE

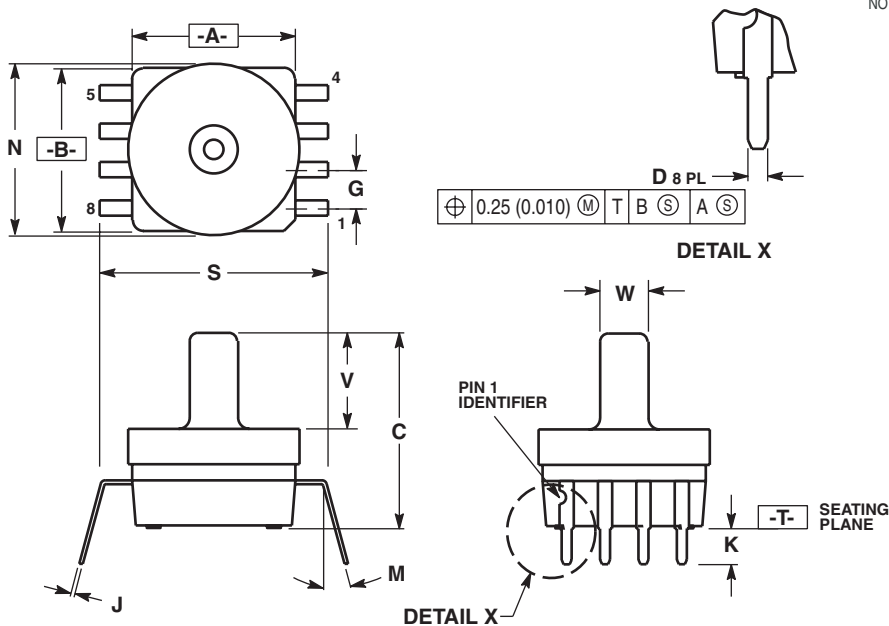

- NOTES:
1. DIMENSIONING AND TOLERANCING PER ANSI Y14.5M, 1982.
 2. CONTROLLING DIMENSION: INCH.
 3. DIMENSION A AND B DO NOT INCLUDE MOLD PROTRUSION.
 4. MAXIMUM MOLD PROTRUSION 0.15 (0.006).
 5. ALL VERTICAL SURFACES 5° TYPICAL DRAFT.
 6. DIMENSION S TO CENTER OF LEAD WHEN FORMED PARALLEL.

DIM	INCHES		MILLIMETERS	
	MIN	MAX	MIN	MAX
A	0.415	0.425	10.54	10.79
B	0.415	0.425	10.54	10.79
C	0.500	0.520	12.70	13.21
D	0.026	0.034	0.66	0.864
G	0.100 BSC		2.54 BSC	
J	0.009	0.011	0.23	0.28
K	0.100	0.120	2.54	3.05
M	0°	15°	0°	15°
N	0.444	0.448	11.28	11.38
S	0.540	0.560	13.72	14.22
V	0.245	0.255	6.22	6.48
W	0.115	0.125	2.92	3.17

CASE 482C-03 ISSUE B SMALL OUTLINE PACKAGE

PACKAGE DIMENSIONS

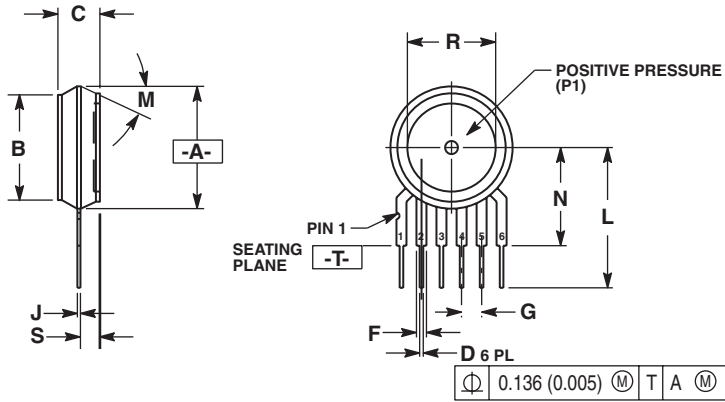

- NOTES:
1. DIMENSIONING AND TOLERANCING PER ANSI Y14.5M, 1982.
 2. CONTROLLING DIMENSION: INCH.
 3. DIMENSION -A- IS INCLUSIVE OF THE MOLD STOP RING. MOLD STOP RING NOT TO EXCEED 16.00 (0.630).

DIM	INCHES		MILLIMETERS	
	MIN	MAX	MIN	MAX
A	0.595	0.630	15.11	16.00
B	0.514	0.534	13.06	13.56
C	0.200	0.220	5.08	5.59
D	0.027	0.033	0.68	0.84
F	0.048	0.064	1.22	1.63
G	0.100 BSC		2.54 BSC	
J	0.014	0.016	0.36	0.40
L	0.695	0.725	17.65	18.42
M	30° NOM		30° NOM	
N	0.475	0.495	12.07	12.57
R	0.430	0.450	10.92	11.43
S	0.090	0.105	2.29	2.66

- STYLE 1:
 PIN 1: VOUT
 2. GROUND
 3. VCC
 4. V1
 5. V2
 6. VEX

- STYLE 2:
 PIN 1: OPEN
 2. GROUND
 3. -VOUT
 4. VSUPPLY
 5. +VOUT
 6. OPEN

- STYLE 3:
 PIN 1: OPEN
 2. GROUND
 3. +VOUT
 4. +VSUPPLY
 5. -VOUT
 6. OPEN

CASE 867-08 ISSUE N UNIBODY PACKAGE

PACKAGE DIMENSIONS

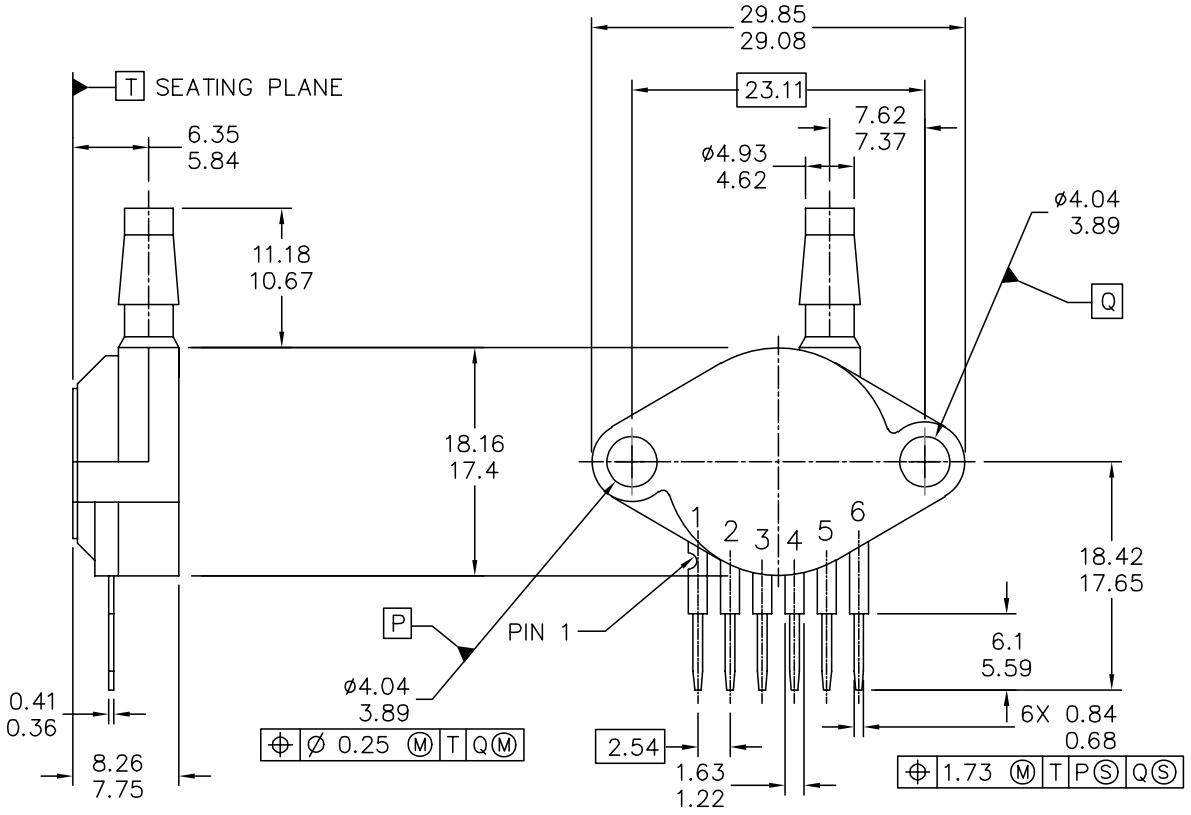

© FREESCALE SEMICONDUCTOR, INC. ALL RIGHTS RESERVED.	MECHANICAL OUTLINE	PRINT VERSION NOT TO SCALE	
TITLE: SENSOR, 6 LEAD UNIBODY CELL, AP & GP 01ASB09087B	DOCUMENT NO: 98ASB42796B	REV: G	
	CASE NUMBER: 867B-04	28 JUL 2005	
	STANDARD: NON-JEDEC		

PAGE 1 OF 2

**CASE 867B-04
ISSUE G
UNIBODY PACKAGE**

MPX5100

PACKAGE DIMENSIONS

NOTES:

1. DIMENSIONS ARE IN MILLIMETERS.
2. DIMENSIONS AND TOLERANCES PER ASME Y14.5M-1994.
3. 867B-01 THRU -3 OBSOLETE, NEW STANDARD 867B-04.

STYLE 1:

PIN 1: V OUT
2: GROUND
3: VCC
4: V1
5: V2
6: V EX

© FREESCALE SEMICONDUCTOR, INC. ALL RIGHTS RESERVED.	MECHANICAL OUTLINE	PRINT VERSION NOT TO SCALE	
TITLE: SENSOR, 6 LEAD UNIBODY CELL, AP & GP 01ASB09087B	DOCUMENT NO: 98ASB42796B	REV: G	
	CASE NUMBER: 867B-04	28 JUL 2005	
	STANDARD: NON-JEDEC		

PAGE 2 OF 2

**CASE 867B-04
ISSUE G
UNIBODY PACKAGE**

PACKAGE DIMENSIONS

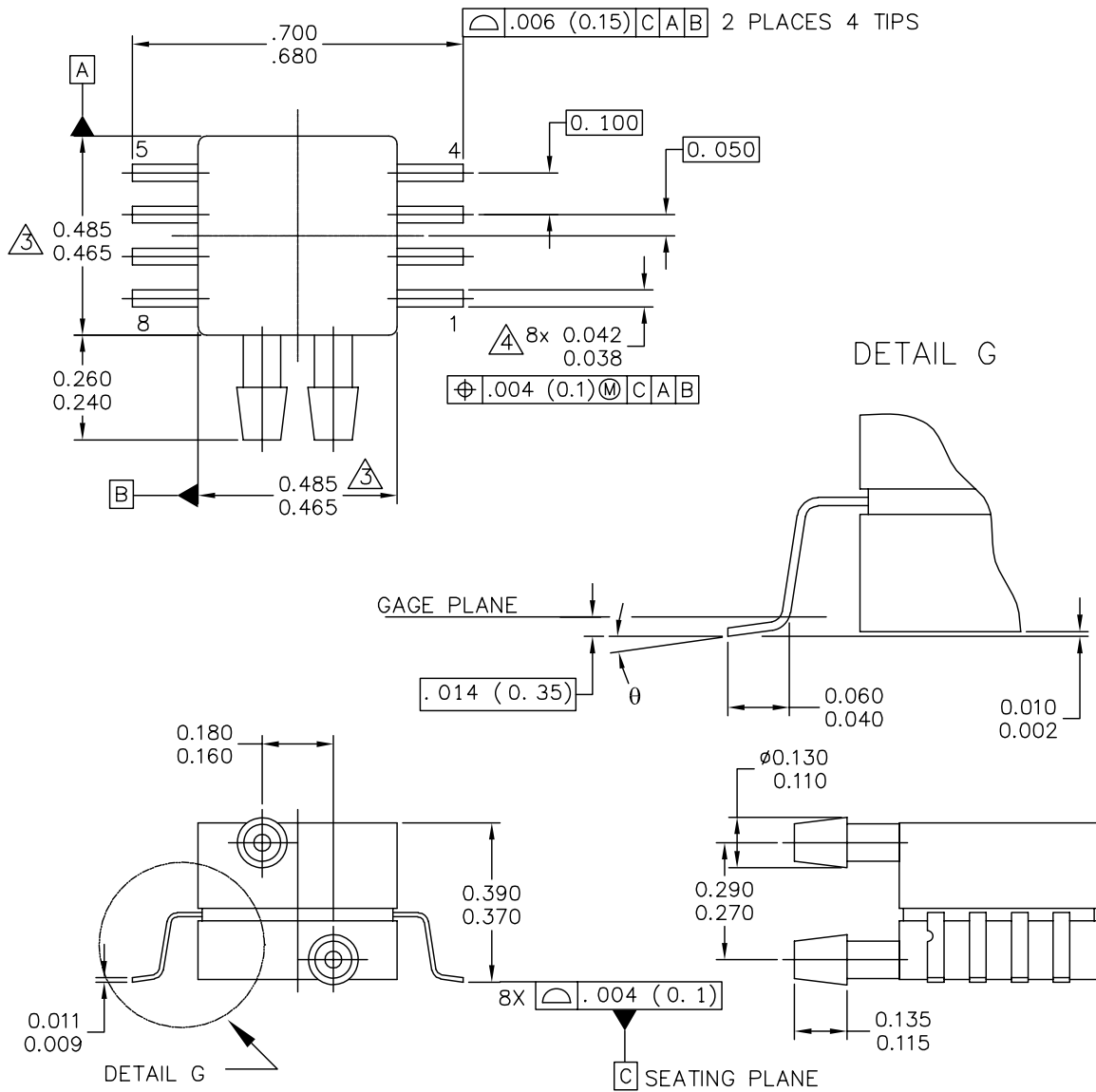

© FREESCALE SEMICONDUCTOR, INC. ALL RIGHTS RESERVED.	MECHANICAL OUTLINE	PRINT VERSION NOT TO SCALE
TITLE: 8 LD SNSR, DUAL PORT	DOCUMENT NO: 98ASA99255D	REV: A
	CASE NUMBER: 1351-01	27 JUL 2005
	STANDARD: NON-JEDEC	

**CASE 1351-01
ISSUE A
SMALL OUTLINE PACKAGE**

PACKAGE DIMENSIONS

NOTES:

1. CONTROLLING DIMENSION: INCH
2. INTERPRET DIMENSIONS AND TOLERANCES PER ASME Y14.5M-1994.
3. DIMENSIONS DO NOT INCLUDE MOLD FLASH OR PROTRUSIONS.
MOLD FLASH AND PROTRUSIONS SHALL NOT EXCEED .006 PER SIDE.
4. DIMENSION DOES NOT INCLUDE DAMBAR PROTRUSION. ALLOWABLE DAMBAR PROTRUSION SHALL BE .008 MAXIMUM.

STYLE 1:

PIN 1: GND
 PIN 2: +Vout
 PIN 3: Vs
 PIN 4: -Vout
 PIN 5: N/C
 PIN 6: N/C
 PIN 7: N/C
 PIN 8: N/C

STYLE 2:

PIN 1: N/C
 PIN 2: Vs
 PIN 3: GND
 PIN 4: Vout
 PIN 5: N/C
 PIN 6: N/C
 PIN 7: N/C
 PIN 8: N/C

© FREESCALE SEMICONDUCTOR, INC. ALL RIGHTS RESERVED.	MECHANICAL OUTLINE	PRINT VERSION NOT TO SCALE	
TITLE: 8 LD SNSR, DUAL PORT	DOCUMENT NO: 98ASA99255D	REV: A	
	CASE NUMBER: 1351-01	27 JUL 2005	
	STANDARD: NON-JEDEC		

PAGE 2 OF 2

**CASE 1351-01
 ISSUE A
 SMALL OUTLINE PACKAGE**

MPX5100

PACKAGE DIMENSIONS

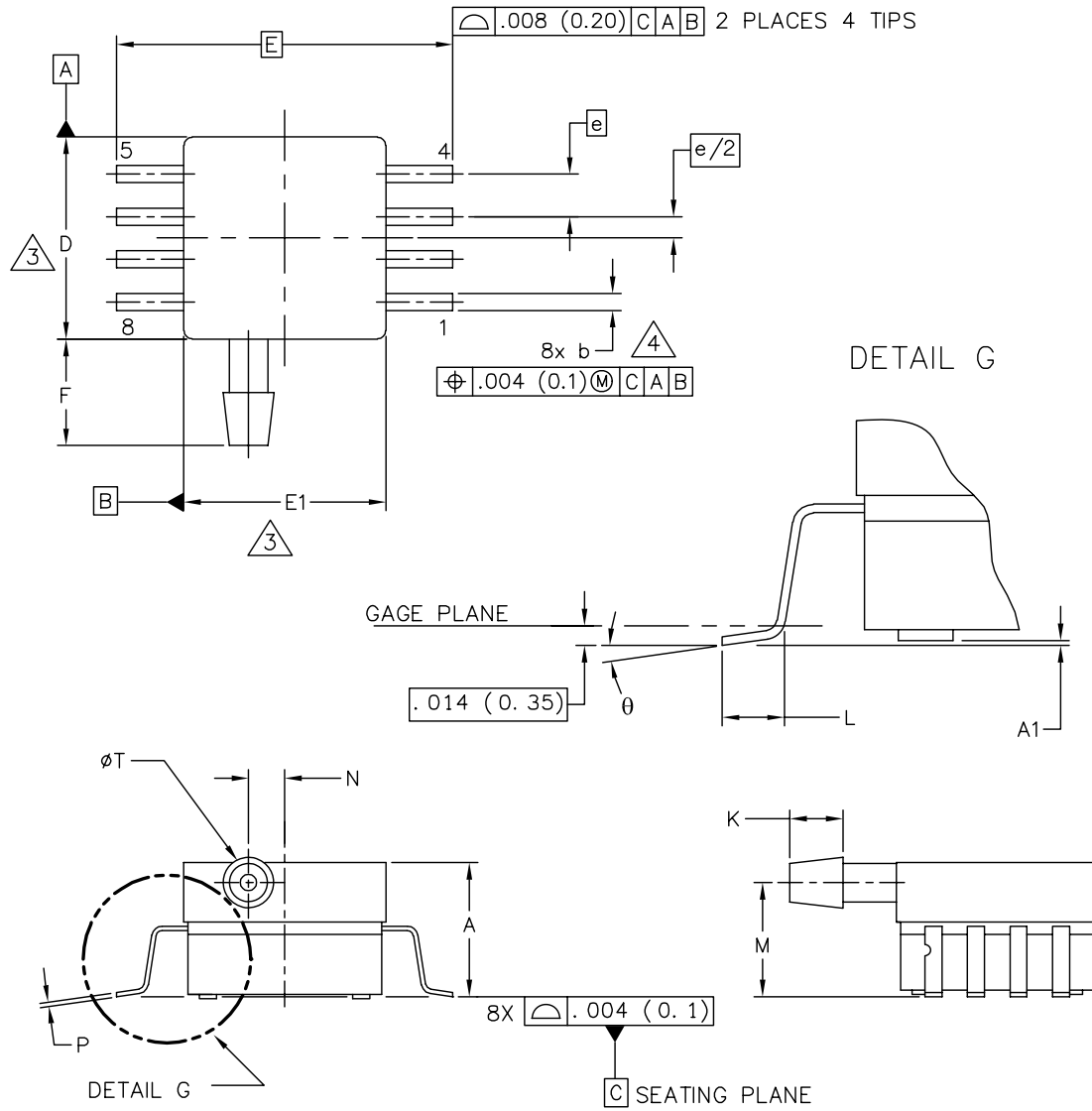

© FREESCALE SEMICONDUCTOR, INC. ALL RIGHTS RESERVED.	MECHANICAL OUTLINE		PRINT VERSION NOT TO SCALE
	TITLE: 8 LD SOP, SIDE PORT		DOCUMENT NO: 98ASA99303D REV: B
		CASE NUMBER: 1369-01	24 MAY 2005
		STANDARD: NON-JEDEC	

PAGE 1 OF 2

**CASE 1369-01
ISSUE B
SMALL OUTLINE PACKAGE**

PACKAGE DIMENSIONS

NOTES:

1. CONTROLLING DIMENSION: INCH
 2. INTERPRET DIMENSIONS AND TOLERANCES PER ASME Y14.5M-1994.
- ③ DIMENSIONS DO NOT INCLUDE MOLD FLASH OR PROTRUSIONS.
MOLD FLASH AND PROTRUSIONS SHALL NOT EXCEED .006 (0.152) PER SIDE.
- ④ DIMENSION DOES NOT INCLUDE DAMBAR PROTRUSION. ALLOWABLE DAMBAR PROTRUSION SHALL BE .008 (0.203) MAXIMUM.

DIM	INCHES		MILLIMETERS		DIM	INCHES		MILLIMETERS	
	MIN	MAX	MIN	MAX		MIN	MAX	MIN	MAX
A	.300	.330	7.11	7.62	θ	0°	7°	0°	7°
A1	.002	.010	0.05	0.25	-	---	---	---	---
b	.038	.042	0.96	1.07	-	---	---	---	---
D	.465	.485	11.81	12.32	-	---	---	---	---
E	.717 BSC		18.21 BSC		-	---	---	---	---
E1	.465	.485	11.81	12.32	-	---	---	---	---
e	.100 BSC		2.54 BSC		-	---	---	---	---
F	.245	.255	6.22	6.47	-	---	---	---	---
K	.120	.130	3.05	3.30	-	---	---	---	---
L	.061	.071	1.55	1.80	-	---	---	---	---
M	.270	.290	6.86	7.36	-	---	---	---	---
N	.080	.090	2.03	2.28	-	---	---	---	---
P	.009	.011	0.23	0.28	-	---	---	---	---
T	.115	.125	2.92	3.17	-	---	---	---	---
© FREESCALE SEMICONDUCTOR, INC. ALL RIGHTS RESERVED.			MECHANICAL OUTLINE			PRINT VERSION NOT TO SCALE			
TITLE: 8 LD SOP, SIDE PORT					DOCUMENT NO: 98ASA99303D			REV: B	
					CASE NUMBER: 1369-01			24 MAY 2005	
					STANDARD: NON-JEDEC				

PAGE 2 OF 2

**CASE 1369-01
ISSUE B
SMALL OUTLINE PACKAGE**

MPX5100

How to Reach Us:

Home Page:

www.freescale.com

Web Support:

<http://www.freescale.com/support>

USA/Europe or Locations Not Listed:

Freescale Semiconductor, Inc.
Technical Information Center, EL516
2100 East Elliot Road
Tempe, Arizona 85284
+1-800-521-6274 or +1-480-768-2130
www.freescale.com/support

Europe, Middle East, and Africa:

Freescale Halbleiter Deutschland GmbH
Technical Information Center
Schatzbogen 7
81829 Muenchen, Germany
+44 1296 380 456 (English)
+46 8 52200080 (English)
+49 89 92103 559 (German)
+33 1 69 35 48 48 (French)
www.freescale.com/support

Japan:

Freescale Semiconductor Japan Ltd.
Headquarters
ARCO Tower 15F
1-8-1, Shimo-Meguro, Meguro-ku,
Tokyo 153-0064
Japan
0120 191014 or +81 3 5437 9125
support.japan@freescale.com

Asia/Pacific:

Freescale Semiconductor Hong Kong Ltd.
Technical Information Center
2 Dai King Street
Tai Po Industrial Estate
Tai Po, N.T., Hong Kong
+800 2666 8080
support.asia@freescale.com

For Literature Requests Only:

Freescale Semiconductor Literature Distribution Center
P.O. Box 5405
Denver, Colorado 80217
1-800-441-2447 or 303-675-2140
Fax: 303-675-2150
LDCForFreescaleSemiconductor@hibbertgroup.com

Information in this document is provided solely to enable system and software implementers to use Freescale Semiconductor products. There are no express or implied copyright licenses granted hereunder to design or fabricate any integrated circuits or integrated circuits based on the information in this document.

Freescale Semiconductor reserves the right to make changes without further notice to any products herein. Freescale Semiconductor makes no warranty, representation or guarantee regarding the suitability of its products for any particular purpose, nor does Freescale Semiconductor assume any liability arising out of the application or use of any product or circuit, and specifically disclaims any and all liability, including without limitation consequential or incidental damages. "Typical" parameters that may be provided in Freescale Semiconductor data sheets and/or specifications can and do vary in different applications and actual performance may vary over time. All operating parameters, including "Typicals", must be validated for each customer application by customer's technical experts. Freescale Semiconductor does not convey any license under its patent rights nor the rights of others. Freescale Semiconductor products are not designed, intended, or authorized for use as components in systems intended for surgical implant into the body, or other applications intended to support or sustain life, or for any other application in which the failure of the Freescale Semiconductor product could create a situation where personal injury or death may occur. Should Buyer purchase or use Freescale Semiconductor products for any such unintended or unauthorized application, Buyer shall indemnify and hold Freescale Semiconductor and its officers, employees, subsidiaries, affiliates, and distributors harmless against all claims, costs, damages, and expenses, and reasonable attorney fees arising out of, directly or indirectly, any claim of personal injury or death associated with such unintended or unauthorized use, even if such claim alleges that Freescale Semiconductor was negligent regarding the design or manufacture of the part.

Freescale™ and the Freescale logo are trademarks of Freescale Semiconductor, Inc. All other product or service names are the property of their respective owners.

© Freescale Semiconductor, Inc. 2008. All rights reserved.

