

Silicon NPN Power Transistors

2SC4510

DESCRIPTION

- With TO-3PML package
- High voltage ,high speed switching
- Low collector saturation voltage

APPLICATIONS

- Switching regulators
- DC-DC convertors
- Solid state relay
- General purpose power amplifiers

PINNING

PIN	DESCRIPTION
1	Base
2	Collector
3	Emitter

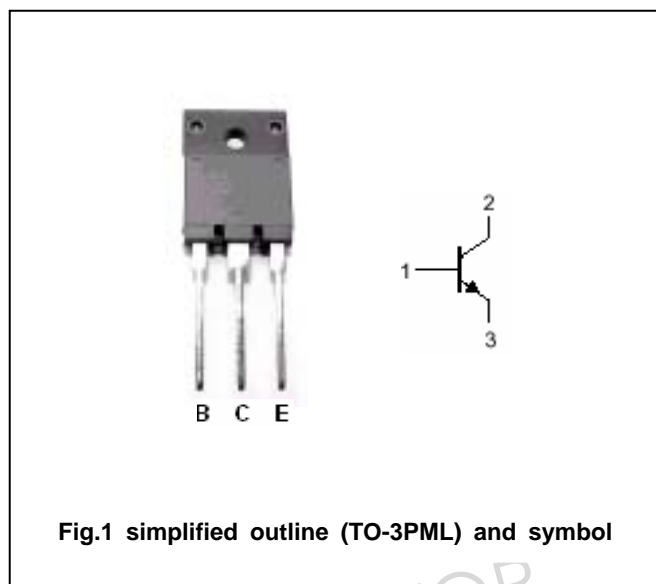

Fig.1 simplified outline (TO-3PML) and symbol

Absolute maximum ratings($T_c=25$)

SYMBOL	PARAMETER	CONDITIONS	VALUE	UNIT
V_{CBO}	Collector-base voltage	Open emitter	500	V
V_{CEO}	Collector-emitter voltage	Open base	400	V
V_{EBO}	Emitter-base voltage	Open collector	10	V
I_C	Collector current		15	A
I_B	Base current		5	A
P_C	Collector power dissipation	$T_c=25$	80	W
T_j	Junction temperature		150	
T_{stg}	Storage temperature		-55~150	

THERMAL CHARACTERISTICS

SYMBOL	PARAMETER	MAX	UNIT
$R_{th\ j-c}$	Thermal resistance junction case	1.56	/W

Silicon NPN Power Transistors

2SC4510

CHARACTERISTICS

T_j=25 unless otherwise specified

SYMBOL	PARAMETER	CONDITIONS	MIN	TYP.	MAX	UNIT
V _{(BR)CBO}	Collector-base breakdown voltage	I _C =1mA; I _E =0	500			V
V _{CEO(SUS)}	Collector-emitter sustaining voltage	I _C =0.2A; I _B =0	400			V
V _{(BR)EBO}	Emitter-base breakdown voltage	I _E =1mA; I _C =0	10			V
V _{CEsat}	Collector-emitter saturation voltage	I _C =6A; I _B =1.2A			0.8	V
V _{BEsat}	Base-emitter saturation voltage	I _C =6A; I _B =1.2A			1.2	V
I _{CBO}	Collector cut-off current	V _{CB} =450V; I _E =0			100	μA
I _{EBO}	Emitter cut-off current	V _{EB} =10V; I _C =0			100	μA
h _{FE}	DC current gain	I _C =2A; V _{CE} =5V	25		65	
Switching times						
t _{on}	Turn-on time	I _C =7.5A; R _L =20 I _{B1} =0.75A; I _{B2} =-1.5A Pw = 20 μs; Duty 2%			1.0	μs
t _{stg}	Storage time				2.5	μs
t _f	Fall time				0.5	μs

Silicon NPN Power Transistors

2SC4510

PACKAGE OUTLINE

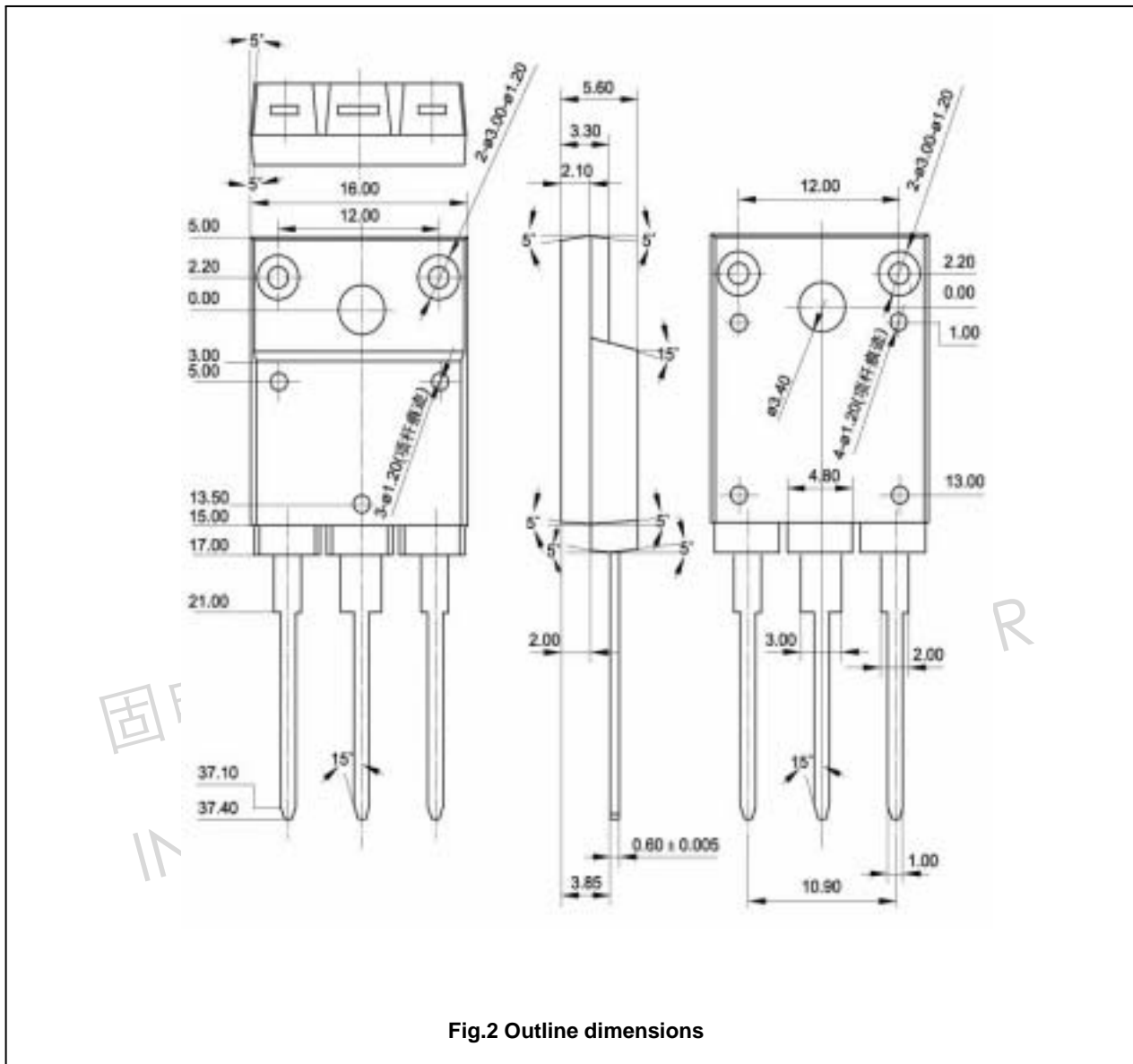

Fig.2 Outline dimensions

Silicon NPN Power Transistors

2SC4510

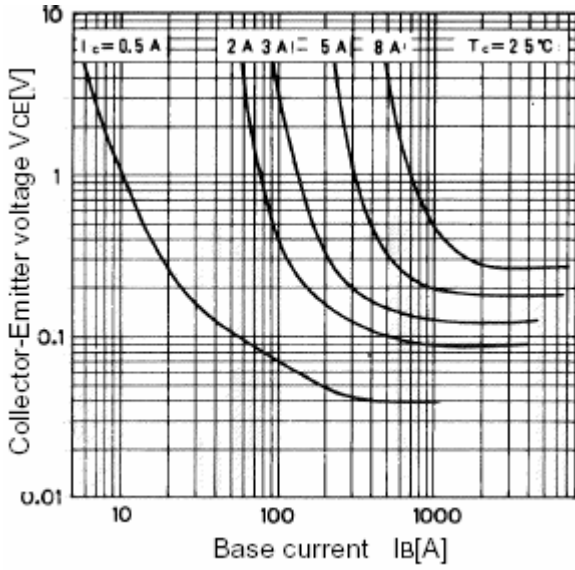

Fig.3 Static Characteristic

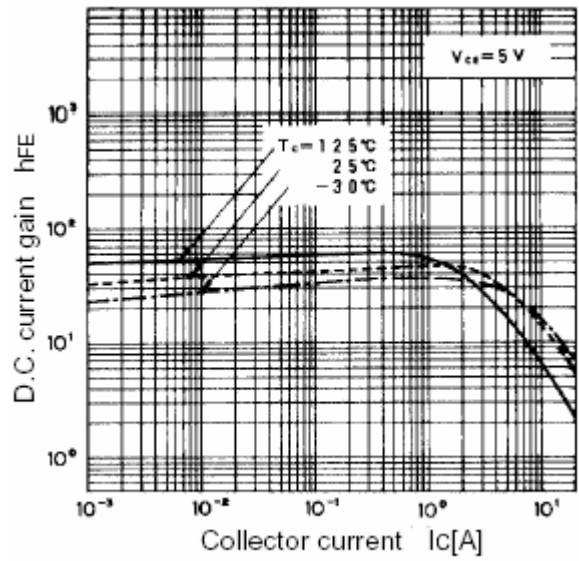

Fig.4 DC current Gain

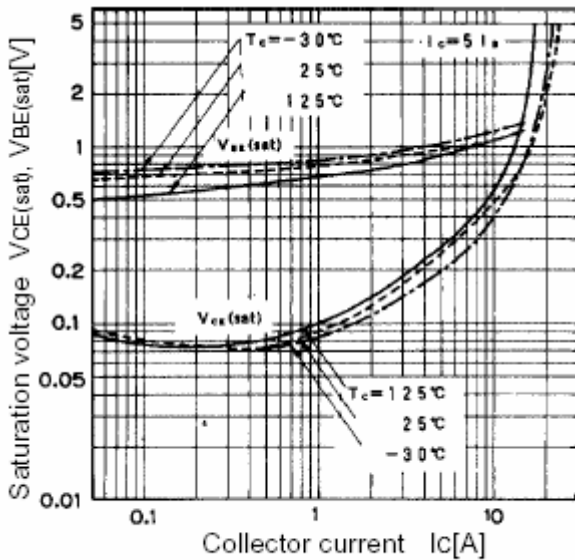

Fig.5 Base-Emitter Saturation Voltage
Collector-Emitter Saturation Voltage

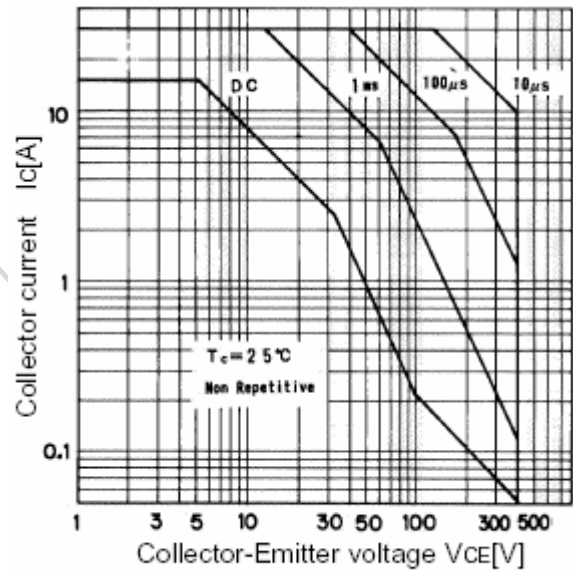

Fig.6 Safe Operating Area