

VI TELEFILTER**Filter Specification****TFS 248 K****1/5****Measurement condition**

Ambient temperature: 23 °C
 Input power level: 0 dBm
 Terminating impedances*): for input: 980 Ω // -5,2 pF
 for output: 940 Ω // -5,3 pF

Characteristics**Remark:**

The maximum of the pass band attenuation a_{max} is defined as the insertion loss a_e . The centre frequency f_c is the arithmetic mean value of the upper and lower frequencies at the 3 dB filter attenuation level relative to the insertion loss a_e . The nominal frequency f_N is fixed at 248 MHz without tolerance. The given values for the absolute attenuation a_{abs} and for the group delay ripple have to be reached at the frequencies given below even if the centre frequency f_c is shifted due to the temperature coefficient of frequency TC_f in the operating temperature range and due to a production tolerance for the centre frequency f_c .

D a t a		typ. value	tolerance / limit
Insertion Loss (reference level)	a_e	4,1 dB	max. 7 dB
Nominal Frequency	f_N	-	248,5 MHz
Centre Frequency	f_c	248,5 MHz	-
Pass band	PB		$f_N \pm 0,2$ MHz
Absolute Attenuation	a_{abs}		
f_N ... $f_N \pm 200$ kHz		4,5 dB	max. 7 dB
$f_N \pm 1$ MHz ... $f_N \pm 2$ MHz		25 dB	min. 15 dB
$f_N \pm 2$ MHz ... $f_N \pm 21,4$ MHz		42 dB	min. 35 dB
$f_N \pm 21,4$ MHz ... $f_N \pm 50$ MHz		65 dB	min. 50 dB
Group Delay Ripple within PB		0,04 µs	max. 0,5 µs
Operating Temperature Range	OTR	-	- 20 °C ... + 70 °C
Storage Temperature Range		-	- 40 °C ... + 85 °C
Frequency Inversion Temperature		20 °C	-
Temperature Coefficient of Frequency	TC_f **	- 0,04 ppm/k ²	-

*) The terminating impedances depend on parasitics and q-values of matching elements and the board used, and are to be understood as reference values only. Should there be additional questions do not hesitate to ask for an application note or contact our design team.

**) $\Delta f(\text{Hz}) = TC_f(\text{ppm/K}) \times (T - T_0)^2 \times f_{T0}(\text{MHz})$.

Generated:**Checked / Approved:**

TELEFILTER GmbH
Potsdamer Straße 18
D 14 513 TELTOW / Germany
Tel: (+49) 3328 4784-0 / Fax: (+49) 3328 4784-30
E-Mail: tft@telefilter.com

VI TELEFILTER reserves the right to make changes to the product(s) and/or information contained herein without notice. No liability is assumed as a result of their use or application. No rights under any patent accompany the sale of any such product(s) or information.

VI TELEFILTER

Filter Specification

TFS 248 K

Construction, pin configuration and 50 Ω - matching network

(All dimensions in mm)

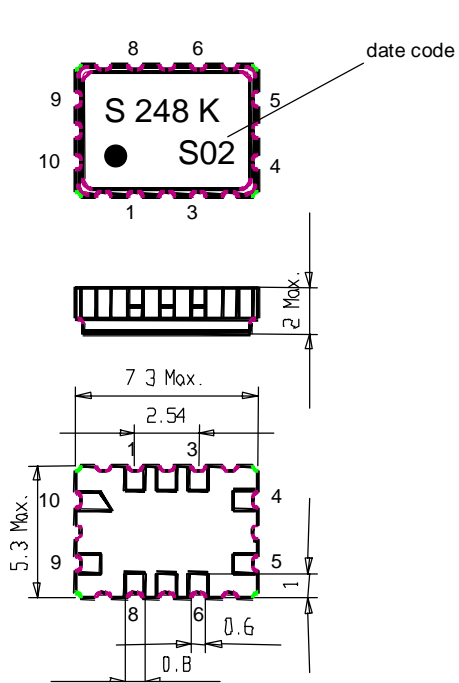

- 1 Ground
- 2 Ground
- 3 Ground
- 4 Output RF - return
- 5 Output
- 6 Ground
- 7 Ground
- 8 Ground
- 9 Input RF - return
- 10 Input

Date code: year + week
 R 2003
 S 2004
 T 2005
 ...

50 Ω matching circuits

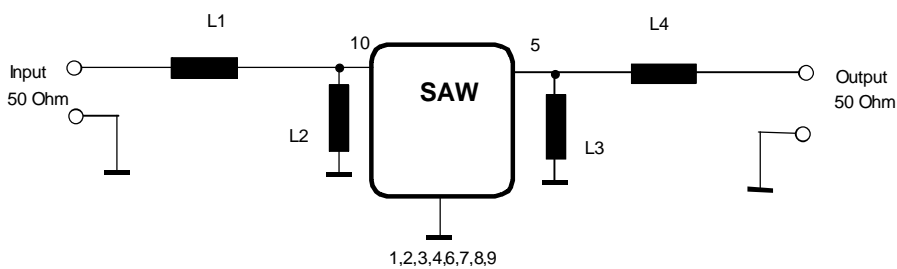

TELEFILTER GmbH
 Potsdamer Straße 18
 D 14 513 TELTOW / Germany
 Tel: (+49) 3328 4784-0 / Fax: (+49) 3328 4784-30
 E-Mail: tft@telefilter.com

VI TELEFILTER reserves the right to make changes to the product(s) and/or information contained herein without notice. No liability is assumed as a result of their use or application. No rights under any patent accompany the sale of any such product(s) or information.

Stability Characteristics

After the following tests the filter shall meet the whole specification:

1. Shock: 500g, 18 ms, half sine wave, 3 shocks each plane;
DIN IEC 68 T2 - 27
2. Vibration: 10 Hz to 500 Hz, 0,35 mm or 5g respectively, 1 octave per min, 10 cycles per plan, 3 plans;
DIN IEC 68 T2 - 6
3. Change of temperature: 25 °C to 55°C / 95% r.H. / 10 cycles
DIN IEC 68 - 2 – 30 Db
4. Resistance to solder heat (reflow): reflow possible: twice max.;
for temperature conditions refer to the attached "Air reflow temperature conditions" on page 4;

Packing

Tape & Reel: IEC 286 - 3, with exception of value for N and minimum bending radius;
tape type II, embossed carrier tape with top cover tape on the upper side;

max. pieces of filters per reel:

3000

Reel of empty components at start:

min 300 mm

Reel of empty components at start including leader:

min 500 mm

Trailer

min 300 mm

Tape (all dimensions in mm)

W	: 16 ± 0,3
Po	: 4 ± 0,1
Do	: 1,5 + 0,1
E	: 1,75 ± 0,1
F	: 7,5 ± 0,1
G (min)	: 0,6
P2	: 2 ± 0,1
P1	: 8 ± 0,1
D1(min)	: 1,5
Ao	: 5,5 ± 0,1
Bo	: 7,5 ± 0,1
CT	: 13,5 ± 0,1

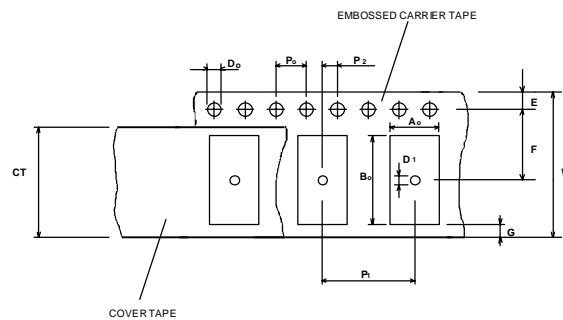

Reel (all dimensions in mm):

A	: 330
W1	: 12,4 ± 2,0
W2 (max)	: 18,4
N (min)	: 50
C	: 13 ± 0,2

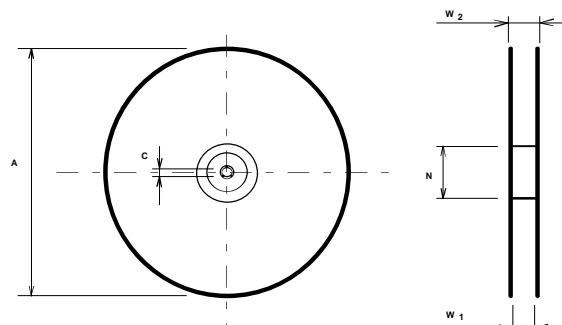

The minimum bending radius is 45 mm. The mounting surface of the filters faces the bottom side of the embossed carrier tape. Markings on the filters can be read if the upper side of the carrier tape is regarded with the sprocket holes on its right.

TELEFILTER GmbH
Potsdamer Straße 18
D 14 513 TELTOW / Germany
Tel: (+49) 3328 4784-0 / Fax: (+49) 3328 4784-30
E-Mail: tft@telefilter.com

VI TELEFILTER reserves the right to make changes to the product(s) and/or information contained herein without notice. No liability is assumed as a result of their use or application. No rights under any patent accompany the sale of any such product(s) or information.

VI TELEFILTER**Filter Specification****TFS 248 K****4/5****Air reflow temperature conditions**

1st and 2nd air reflow profile

Name:	pre-heating periods	main-heating periods	peak temperature
Temperature:	150 °C - 170 °C	over 200 °C	255 °C ± 5 °C
Time:	60 sec. - 90 sec.	20 sec. - 25 sec.	

Chip-mount air reflow profile

Table for temperature vs. time during the air reflow process

Tolerance of temperatures: ± 5 °C

time / sec.	temperature / °C	time / sec.	temperature / °C
0	23	140	160
10	34	150	161
20	46	160	164
30	60	170	170
40	80	180	180
50	103	190	205
60	121	195	230
70	134	200	255
80	143	205	230
90	150	210	205
100	154	215	180
110	156	220	165
120	158	230	140
130	159	240	120

TELEFILTER GmbH
 Potsdamer Straße 18
 D 14 513 TELTOW / Germany
 Tel: (+49) 3328 4784-0 / Fax: (+49) 3328 4784-30
 E-Mail: tft@telefilter.com

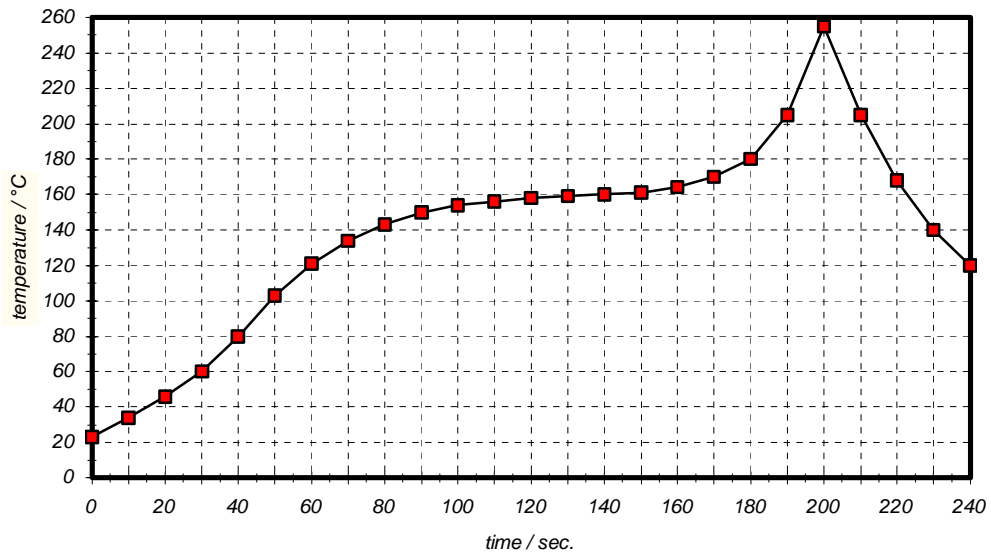
VI TELEFILTER reserves the right to make changes to the product(s) and/or information contained herein without notice. No liability is assumed as a result of their use or application. No rights under any patent accompany the sale of any such product(s) or information.

VI TELEFILTER**Filter Specification****TFS 248 K****5/5****History**

Version	Reason of Changes	Name	Date
1.0	generation of development specification	Konietzko	15.09.2003
1.1	terminating impedance (preliminary values), typical values and matching configuration added 04.12.2003		Pfeiffer
1.2	package drawing corrected, terminating impedance fixed, typical value changed	Pfeiffer	08.01.2004

TELEFILTER GmbH
Potsdamer Straße 18
D 14 513 TELTOW / Germany
Tel: (+49) 3328 4784-0 / Fax: (+49) 3328 4784-30
E-Mail: tft@telefilter.com

VI TELEFILTER reserves the right to make changes to the product(s) and/or information contained herein without notice. No liability is assumed as a result of their use or application. No rights under any patent accompany the sale of any such product(s) or information.