



# Frontier Electronics Corp.

667 E. COCHRAN STREET, SIMI VALLEY, CA 93065

TEL: (805) 522-9998 FAX: (805) 522-9989

E-mail: frontiersales@frontierusa.com

Web: frontierusa.com

## CCFL Inverter Transformer—SIH1510-02

### A. Electrical specification:

Part No.	Mark	Suitable Frequency	Max. Open Voltage	Max. Lamp Watt.	Efficiency
SIH1510-02	SIH1510-02	40KHz~200KHz	1800 V rms.	6W	78%

### B. Schematics and Mechanical dimensions: (Unit: mm)

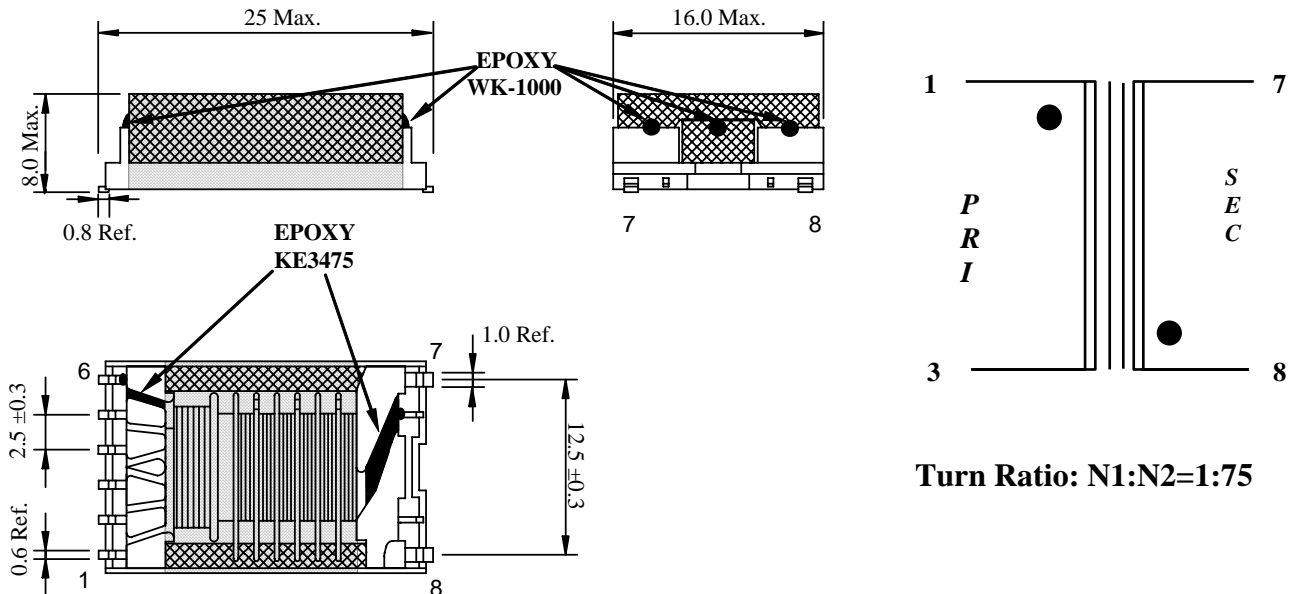

### C. Electrical Data:

Term	Item	Spec.	Condition
Hi-Pot	Secondary to Core	2600 VAC / 3.0 Seconds	@Cut off current=3mA
	Pri. To Core / Sec. to Core	600 VAC / 3.0 Seconds	
Isolation	Pri. to Sec. / Pri. To Core / Sec. to Core	100 MΩ Min.	@ 500 VDC

### D. Insulation:

Winding	Start	Finish	L (@ 50KHz, 1.0V)	DCR Ω (@25°C)
Primary	1	3		0.250 Max.
Secondary	8	7	1.60 H Ref.	110 Max.

Le (@50KHz/1.0V) with pin #1 to #3 shorted: 190 mH

### E. Features:

- Low profile height: Maximum 5.0mm.
- High efficiency.
- Surface mount.
- Suitable for standard IR re-flows soldering.

### F. Uses:

- Black Light power supplies transformer Available.
- Personal Computer.

Note: **RoHS** compliant; for the **ROHS** parts, we add “-LFR” at the end of the P/N.