

Features

- Two High-side Outputs for Grounded Red Laser Diodes
- Total Output Current up to 700 mA at VLD = 3.8V

- One Low-side Output for Floating Blue Laser Diode
- Total Output Current up to 550 mA, External LD Supply Voltage

- Five Channels with Gain DACs
- Two Current Inputs for Read and Write Channels
- Channel 2 Current Contribution up to 350 mA

- LVDS-compatible Enable Inputs at Channels 2, 3, 4 and HFM
- Optional SyncDrive Technology for Increased Timing Accuracy
- Common Enable Input for All Channels

- Low-EMI High-Frequency Modulator (HFM) with Wiper
 - Frequency Range 200 MHz to 500 MHz
 - Swing up to 100 mApp
 - Erase Modulation Supported

- Serial Interface (SPI and TWI) with Write and Read Operation
 - LD Output
 - Channel Gains and Input Current Source
 - Overcurrent Protection
 - HFM Frequency and Swing
 - HFM Frequency Measurement
 - LVDS/Single Ended Input Configurations
 - SyncDrive Mode
 - Temperature Monitor
 - Blue LD Voltage Monitor

- Small, Pb-free, 24-pin, Paddle-up Package 4 mm × 4 mm

Applications

- Blu-ray/DVD/CD Recordable Drives
- Blu-ray Combo Drives

Benefits

- The Serial Interface Yields the Following Benefits:
 - Low Pin Count and Small Package
 - Flexible Channel Configurations
 - Digital Gain Control
 - High Accuracy of HFM Frequency



3-output Laser Driver with 5 Channels and Serial Interface

ATR0881

Preliminary

Summary

NOTE: This is a summary document. The complete document is available. For more information, please contact your local Atmel sales office.

9105BS-DVD-03/08



1. Description

The ATR0881 is a laser diode driver designed to operate two grounded red laser diodes for CD and DVD and one floating blue laser diode for Blu-ray. The floating blue laser diode needs an extra supply voltage V_H . The serial interface (SPI and TWI supported) makes ATR0881 very flexible and configurable for a wide range of applications. Five channels can be assigned to one of the two reference current inputs IR and IW. The channel gains can be individually set by DACs. Prescalers with 2 bits are provided to increase the resolution. Overcurrent protection circuits supervise the reference current inputs. The channel enable inputs can be configured as single ended or LVDS. In SyncDrive mode, channels 3, 4, and 5 are synchronized to channel 2. The on-chip spread spectrum HFM with low EMI reduces laser mode hopping noise. All HFM frequency and swing parameters can be set by the serial interface. A high frequency-accuracy can be achieved by the frequency counter feature. HFM enable can be configured as single ended or LVDS or automatically-disabling by write channels.

2. Pin Configuration

Figure 2-1. Pinning QFN24

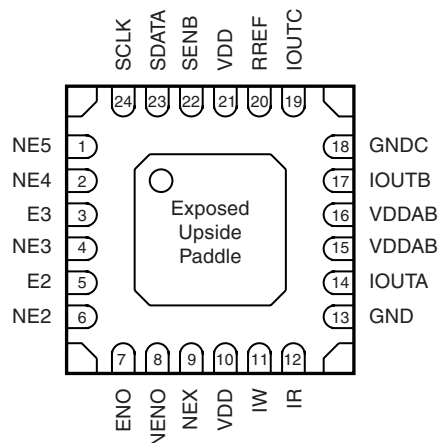

Table 2-1. Pin Description

Pin	Symbol	Type	Function
1	NE5	Digital in	Enable channel 5 (inverting, single ended) or enable channel 4 (non-inverting, LVDS)
2	NE4	Digital in	Enable channel 4 (inverting, LVDS, or single ended)
3	E3	Digital in	Enable channel 3 (non-inverting, LVDS)
4	NE3	Digital in	Enable channel 3 (inverting, LVDS, or single ended)
5	E2	Digital in	Enable channel 2 (non-inverting, LVDS)
6	NE2	Digital in	Enable channel 2 (inverting, LVDS, or single ended)
7	ENO	Digital in	Enable HFM (non-inverting, LVDS, or single ended)
8	NENO	Digital in	Enable HFM (inverting, LVDS)
9	NEX	Digital in	Multipurpose enable input (inverting, all channels, channel 1, write channels)
10	VDD	Supply	Power supply
11	IW	Analog in	Reference current input for write channels
12	IR	Analog in	Reference current input for read channels
13	GND	Supply	GND
14	IOUTA	Analog out	Laser diode anode connection
15, 16	VDDAB	Supply	Power supply for outputs IOUTA and IOUTB
17	IOUTB	Analog out	Laser diode anode connection
18	GNDC	Supply	GND for output IOUTC
19	IOUTC	Analog out	Laser diode cathode connection
20	RREF	Analog in	Reference current input for HFM and overcurrent detector
21	VDD	Supply	Power supply
22	SENB	Digital in	Serial enable
23	SDATA	Digital in/out	Serial data input and output
24	SCLK	Digital in	Serial clock
Corners			Paddle – at least one corner has to be connected to GND

3. Absolute Maximum Ratings

Stresses beyond those listed under “Absolute Maximum Ratings” may cause permanent damage to the device. This is a stress rating only and functional operation of the device at these or any other conditions beyond those indicated in the operational sections of this specification is not implied. Exposure to absolute maximum rating conditions for extended periods may affect device reliability.

Parameters	Pin	Symbol	Value	Unit
Supply voltage	10, 15, 16, 21	V_{DD}	-0.3 to +6.0	V
Input voltage at any pin		V_{IN}	-0.3 to $V_{DD} + 0.3$	V
Current into IR, IW and RREF pins (no voltage source allowed)	11, 12, 20	I_{IN}	0 to 4	mA
Power dissipation		P	0.7 ⁽¹⁾ to 1 ⁽²⁾	W
Junction temperature		T_j	150	°C
Storage temperature		T_{stg}	-65 to +125	°C

- Notes: 1. $R_{thJA} \leq 115^\circ\text{C/W}$ at $T_{amb} = 70^\circ\text{C}$
 2. $R_{thJA} \leq 115^\circ\text{C/W}$ at $T_{amb} = 25^\circ\text{C}$

4. Thermal Resistance

Parameters	Symbol	Value	Unit
Junction-ambient	R_{thJA}	50	°C/W

Note: Package thermal resistance is measured on the ATR0881 demo board without heat spreader. Users should ensure that the junction temperature never exceeds 150°C. Thermal resistance from junction to case and to ambient depends very much on the PCB layout and on heat spreading measures.

5. Recommended Operating Conditions

Parameters	Pin	Symbol	Value	Unit
Supply voltage	10, 15, 16, 21	V_{DD}	4.5 to 5.5	V
Input current	11, 12	I_R, I_W	≤ 2	mA
External reference resistor to GND	20	R_{REF}	13 \pm 1%	k Ω
Operating voltage at IOUTC output	19	V_{IOUTC}	0.8 to 4.0 ⁽¹⁾	V
Operating temperature range		T_{amb}	0 to +70	°C

Note: 1. Adjust supply voltage V_H of blue laser diode to keep V_{IOUTC} within the specified range for all operating modes of the laser diode to avoid degradation of the laser diode.

6. Ordering Information

Extended Type Number	Package	Remarks
ATR0881-PTQW	QFN24_PUP	Taped and reeled

7. Package Information

Package: QFN_PUP_4 x 4_24L
 Exposed pad 2.2 x 2.2
 Dimensions in mm
 Not indicated tolerances ± 0.05

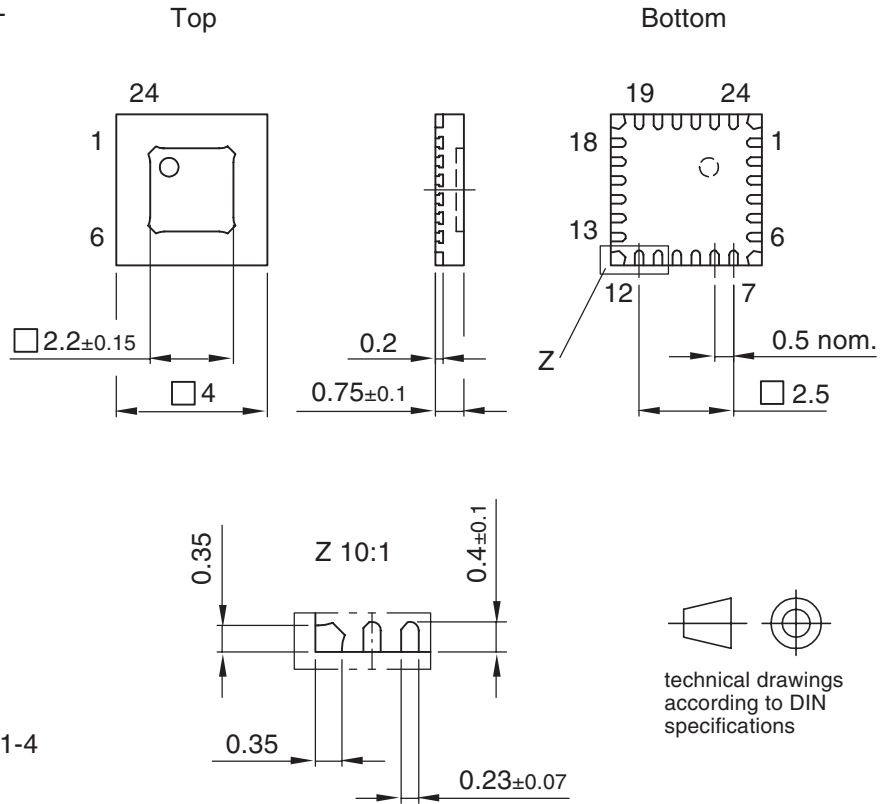

Drawing-No.: 6.543-5106.01-4
 Issue: 1; 18.03.04

8. Revision History

Please note that the following page numbers referred to in this section refer to the specific revision mentioned, not to this document.

Revision No.	History
9105BS-DVD-03/08	<ul style="list-style-type: none"> All TWI parts added Applications on page 1 changed Section 4 "Thermal Resistance" on page 4 changed



Headquarters

Atmel Corporation
2325 Orchard Parkway
San Jose, CA 95131
USA
Tel: 1(408) 441-0311
Fax: 1(408) 487-2600

International

Atmel Asia
Room 1219
Chinachem Golden Plaza
77 Mody Road Tsimshatsui
East Kowloon
Hong Kong
Tel: (852) 2721-9778
Fax: (852) 2722-1369

Atmel Europe
Le Krebs
8, Rue Jean-Pierre Timbaud
BP 309
78054
Saint-Quentin-en-Yvelines Cedex
France
Tel: (33) 1-30-60-70-00
Fax: (33) 1-30-60-71-11

Atmel Japan
9F, Tonetsu Shinkawa Bldg.
1-24-8 Shinkawa
Chuo-ku, Tokyo 104-0033
Japan
Tel: (81) 3-3523-3551
Fax: (81) 3-3523-7581

Product Contact

Web Site
www.atmel.com

Technical Support
dvd_1dd@atmel.com

Sales Contact
www.atmel.com/contacts

Literature Requests
www.atmel.com/literature

Disclaimer: The information in this document is provided in connection with Atmel products. No license, express or implied, by estoppel or otherwise, to any intellectual property right is granted by this document or in connection with the sale of Atmel products. **EXCEPT AS SET FORTH IN ATMEL'S TERMS AND CONDITIONS OF SALE LOCATED ON ATMEL'S WEB SITE, ATMEL ASSUMES NO LIABILITY WHATSOEVER AND DISCLAIMS ANY EXPRESS, IMPLIED OR STATUTORY WARRANTY RELATING TO ITS PRODUCTS INCLUDING, BUT NOT LIMITED TO, THE IMPLIED WARRANTY OF MERCHANTABILITY, FITNESS FOR A PARTICULAR PURPOSE, OR NON-INFRINGEMENT. IN NO EVENT SHALL ATMEL BE LIABLE FOR ANY DIRECT, INDIRECT, CONSEQUENTIAL, PUNITIVE, SPECIAL OR INCIDENTAL DAMAGES (INCLUDING, WITHOUT LIMITATION, DAMAGES FOR LOSS OF PROFITS, BUSINESS INTERRUPTION, OR LOSS OF INFORMATION) ARISING OUT OF THE USE OR INABILITY TO USE THIS DOCUMENT, EVEN IF ATMEL HAS BEEN ADVISED OF THE POSSIBILITY OF SUCH DAMAGES.** Atmel makes no representations or warranties with respect to the accuracy or completeness of the contents of this document and reserves the right to make changes to specifications and product descriptions at any time without notice. Atmel does not make any commitment to update the information contained herein. Unless specifically provided otherwise, Atmel products are not suitable for, and shall not be used in, automotive applications. Atmel's products are not intended, authorized, or warranted for use as components in applications intended to support or sustain life.

© 2007 Atmel Corporation. All rights reserved. Atmel®, logo and combinations thereof, and others are registered trademarks or trademarks of Atmel Corporation or its subsidiaries. Other terms and product names may be trademarks of others.