

The revision list can be viewed directly by clicking the title page.

The revision list summarizes the locations of revisions and additions. Details should always be checked by referring to the relevant text.

**32**

# SH7125 Group, SH7124 Group

## Hardware Manual

Renesas 32-Bit RISC Microcomputer  
SuperH™ RISC engine Family

SH7125	R5F7125
SH7124	R5F7124

Hardware Manual

Rev.4.00  
Revision Date: Jul. 25, 2008

Renesas Technology  
www.renesas.com



## Notes regarding these materials

1. This document is provided for reference purposes only so that Renesas customers may select the appropriate Renesas products for their use. Renesas neither makes warranties or representations with respect to the accuracy or completeness of the information contained in this document nor grants any license to any intellectual property rights or any other rights of Renesas or any third party with respect to the information in this document.
2. Renesas shall have no liability for damages or infringement of any intellectual property or other rights arising out of the use of any information in this document, including, but not limited to, product data, diagrams, charts, programs, algorithms, and application circuit examples.
3. You should not use the products or the technology described in this document for the purpose of military applications such as the development of weapons of mass destruction or for the purpose of any other military use. When exporting the products or technology described herein, you should follow the applicable export control laws and regulations, and procedures required by such laws and regulations.
4. All information included in this document such as product data, diagrams, charts, programs, algorithms, and application circuit examples, is current as of the date this document is issued. Such information, however, is subject to change without any prior notice. Before purchasing or using any Renesas products listed in this document, please confirm the latest product information with a Renesas sales office. Also, please pay regular and careful attention to additional and different information to be disclosed by Renesas such as that disclosed through our website. (<http://www.renesas.com>)
5. Renesas has used reasonable care in compiling the information included in this document, but Renesas assumes no liability whatsoever for any damages incurred as a result of errors or omissions in the information included in this document.
6. When using or otherwise relying on the information in this document, you should evaluate the information in light of the total system before deciding about the applicability of such information to the intended application. Renesas makes no representations, warranties or guaranties regarding the suitability of its products for any particular application and specifically disclaims any liability arising out of the application and use of the information in this document or Renesas products.
7. With the exception of products specified by Renesas as suitable for automobile applications, Renesas products are not designed, manufactured or tested for applications or otherwise in systems the failure or malfunction of which may cause a direct threat to human life or create a risk of human injury or which require especially high quality and reliability such as safety systems, or equipment or systems for transportation and traffic, healthcare, combustion control, aerospace and aeronautics, nuclear power, or undersea communication transmission. If you are considering the use of our products for such purposes, please contact a Renesas sales office beforehand. Renesas shall have no liability for damages arising out of the uses set forth above.
8. Notwithstanding the preceding paragraph, you should not use Renesas products for the purposes listed below:
  - (1) artificial life support devices or systems
  - (2) surgical implantations
  - (3) healthcare intervention (e.g., excision, administration of medication, etc.)
  - (4) any other purposes that pose a direct threat to human lifeRenesas shall have no liability for damages arising out of the uses set forth in the above and purchasers who elect to use Renesas products in any of the foregoing applications shall indemnify and hold harmless Renesas Technology Corp., its affiliated companies and their officers, directors, and employees against any and all damages arising out of such applications.
9. You should use the products described herein within the range specified by Renesas, especially with respect to the maximum rating, operating supply voltage range, movement power voltage range, heat radiation characteristics, installation and other product characteristics. Renesas shall have no liability for malfunctions or damages arising out of the use of Renesas products beyond such specified ranges.
10. Although Renesas endeavors to improve the quality and reliability of its products, IC products have specific characteristics such as the occurrence of failure at a certain rate and malfunctions under certain use conditions. Please be sure to implement safety measures to guard against the possibility of physical injury, and injury or damage caused by fire in the event of the failure of a Renesas product, such as safety design for hardware and software including but not limited to redundancy, fire control and malfunction prevention, appropriate treatment for aging degradation or any other applicable measures. Among others, since the evaluation of microcomputer software alone is very difficult, please evaluate the safety of the final products or system manufactured by you.
11. In case Renesas products listed in this document are detached from the products to which the Renesas products are attached or affixed, the risk of accident such as swallowing by infants and small children is very high. You should implement safety measures so that Renesas products may not be easily detached from your products. Renesas shall have no liability for damages arising out of such detachment.
12. This document may not be reproduced or duplicated, in any form, in whole or in part, without prior written approval from Renesas.
13. Please contact a Renesas sales office if you have any questions regarding the information contained in this document, Renesas semiconductor products, or if you have any other inquiries.

## General Precautions on Handling of Product

### 1. Treatment of NC Pins

Note: Do not connect anything to the NC pins.

The NC (not connected) pins are either not connected to any of the internal circuitry or are used as test pins or to reduce noise. If something is connected to the NC pins, the operation of the LSI is not guaranteed.

### 2. Treatment of Unused Input Pins

Note: Fix all unused input pins to high or low level.

Generally, the input pins of CMOS products are high-impedance input pins. If unused pins are in their open states, intermediate levels are induced by noise in the vicinity, a pass-through current flows internally, and a malfunction may occur.

### 3. Processing before Initialization

Note: When power is first supplied, the product's state is undefined.

The states of internal circuits are undefined until full power is supplied throughout the chip and a low level is input on the reset pin. During the period where the states are undefined, the register settings and the output state of each pin are also undefined. Design your system so that it does not malfunction because of processing while it is in this undefined state. For those products which have a reset function, reset the LSI immediately after the power supply has been turned on.

### 4. Prohibition of Access to Undefined or Reserved Addresses

Note: Access to undefined or reserved addresses is prohibited.

The undefined or reserved addresses may be used to expand functions, or test registers may have been allocated to these addresses. Do not access these registers; the system's operation is not guaranteed if they are accessed.

# Configuration of This Manual

This manual comprises the following items:

1. General Precautions on Handling of Product
2. Configuration of This Manual
3. Preface
4. Contents
5. Overview
6. Description of Functional Modules
  - CPU and System-Control Modules
  - On-Chip Peripheral Modules

The configuration of the functional description of each module differs according to the module. However, the generic style includes the following items:

  - i) Feature
  - ii) Input/Output Pin
  - iii) Register Description
  - iv) Operation
  - v) Usage Note

When designing an application system that includes this LSI, take notes into account. Each section includes notes in relation to the descriptions given, and usage notes are given, as required, as the final part of each section.

7. List of Registers
8. Electrical Characteristics
9. Appendix
10. Main Revisions and Additions in this Edition (only for revised versions)

The list of revisions is a summary of points that have been revised or added to earlier versions. This does not include all of the revised contents. For details, see the actual locations in this manual.

11. Index

# Preface

The SH7125 Group and SH7124 Group RISC (Reduced Instruction Set Computer) microcomputer include a Renesas Technology-original RISC CPU as its core, and the peripheral functions required to configure a system.

**Target Users:** This manual was written for users who will be using the SH7125 Group and SH7124 Group in the design of application systems. Target users are expected to understand the fundamentals of electrical circuits, logical circuits, and microcomputers.

**Objective:** This manual was written to explain the hardware functions and electrical characteristics of the SH7125 Group and SH7124 Group to the target users. Refer to the SH-1/SH-2/SH-DSP Software Manual for a detailed description of the instruction set.

Notes on reading this manual:

- In order to understand the overall functions of the chip  
Read the manual according to the contents. This manual can be roughly categorized into parts on the CPU, system control functions, peripheral functions and electrical characteristics.
- In order to understand the details of the CPU's functions  
Read the SH-1/SH-2/SH-DSP Software Manual.
- In order to understand the details of a register when its name is known  
Read the index that is the final part of the manual to find the page number of the entry on the register. The addresses, bits, and initial values of the registers are summarized in section 20, List of Registers.

**Examples:**

Register name:	The following notation is used for cases when the same or a similar function, e.g. serial communication interface, is implemented on more than one channel: XXX_N (XXX is the register name and N is the channel number)
Bit order:	The MSB is on the left and the LSB is on the right.
Number notation:	Binary is B'xxxx, hexadecimal is H'xxxx, decimal is xxxx.
Signal notation:	An overbar is added to a low-active signal: $\overline{\text{xxxx}}$

**Related Manuals:** The latest versions of all related manuals are available from our web site. Please ensure you have the latest versions of all documents you require.  
<http://www.renesas.com/>

SH7125 Group and SH7124 Group manuals:

<b>Document Title</b>	<b>Document No.</b>
SH7125 Group, SH7124 Group Hardware Manual	This manual
SH-1/SH-2/SH-DSP Software Manual	REJ09B0171

User's manuals for development tools:

<b>Document Title</b>	<b>Document No.</b>
SuperH™ RISC engine C/C++ Compiler, Assembler, Optimizing Linkage Editor Compiler Package V.9.00 User's Manual	REJ10B0152
SuperH™ RISC engine High-performance Embedded Workshop 3 User's Manual	REJ10B0025
SuperH RISC engine High-Performance Embedded Workshop 3 Tutorial	REJ10B0023

Application note:

<b>Document Title</b>	<b>Document No.</b>
SuperH RISC engine C/C++ Compiler Package Application Note	REJ05B0463

All trademarks and registered trademarks are the property of their respective owners.





# Contents

Section 1	Overview.....	1
1.1	Features of SH7125 and SH7124.....	1
1.2	Block Diagram.....	6
1.3	Pin Assignments .....	7
1.4	Pin Functions .....	11
Section 2	CPU.....	17
2.1	Features.....	17
2.2	Register Configuration.....	18
2.2.1	General Registers (Rn).....	19
2.2.2	Control Registers .....	19
2.2.3	System Registers.....	21
2.2.4	Initial Values of Registers.....	21
2.3	Data Formats.....	22
2.3.1	Register Data Format .....	22
2.3.2	Memory Data Formats .....	22
2.3.3	Immediate Data Formats.....	23
2.4	Features of Instructions.....	23
2.4.1	RISC Type .....	23
2.4.2	Addressing Modes .....	26
2.4.3	Instruction Formats .....	29
2.5	Instruction Set.....	33
2.5.1	Instruction Set by Type.....	33
2.5.2	Data Transfer Instructions .....	37
2.5.3	Arithmetic Operation Instructions .....	39
2.5.4	Logic Operation Instructions .....	41
2.5.5	Shift Instructions.....	42
2.5.6	Branch Instructions.....	43
2.5.7	System Control Instructions.....	44
2.6	Processing States.....	46
Section 3	MCU Operating Modes .....	49
3.1	Selection of Operating Modes .....	49
3.2	Input/Output Pins.....	50
3.3	Operating Modes.....	50
3.3.1	Mode 3 (Single Chip Mode).....	50

3.4	Address Map .....	51
3.5	Initial State in This LSI.....	54
3.6	Note on Changing Operating Mode .....	54
<b>Section 4 Clock Pulse Generator (CPG) .....</b>		<b>55</b>
4.1	Features.....	55
4.2	Input/Output Pins .....	58
4.3	Clock Operating Mode.....	59
4.4	Register Descriptions .....	61
4.4.1	Frequency Control Register (FRQCR) .....	61
4.4.2	Oscillation Stop Detection Control Register (OSCCR) .....	64
4.5	Changing Frequency .....	65
4.6	Oscillator.....	66
4.6.1	Connecting Crystal Resonator .....	66
4.6.2	External Clock Input Method.....	67
4.7	Function for Detecting Oscillator Stop .....	68
4.8	Usage Notes .....	69
4.8.1	Note on Crystal Resonator .....	69
4.8.2	Notes on Board Design .....	69
<b>Section 5 Exception Handling .....</b>		<b>71</b>
5.1	Overview.....	71
5.1.1	Types of Exception Handling and Priority .....	71
5.1.2	Exception Handling Operations .....	72
5.1.3	Exception Handling Vector Table .....	73
5.2	Resets .....	75
5.2.1	Types of Resets .....	75
5.2.2	Power-On Reset .....	75
5.2.3	Manual Reset .....	76
5.3	Address Errors .....	77
5.3.1	Address Error Sources .....	77
5.3.2	Address Error Exception Source.....	78
5.4	Interrupts.....	79
5.4.1	Interrupt Sources.....	79
5.4.2	Interrupt Priority .....	80
5.4.3	Interrupt Exception Handling .....	80
5.5	Exceptions Triggered by Instructions .....	81
5.5.1	Types of Exceptions Triggered by Instructions .....	81
5.5.2	Trap Instructions .....	81
5.5.3	Illegal Slot Instructions .....	82

5.5.4	General Illegal Instructions.....	82
5.6	Cases when Exceptions are Accepted.....	83
5.7	Stack States after Exception Handling Ends.....	84
5.8	Usage Notes.....	86
5.8.1	Value of Stack Pointer (SP).....	86
5.8.2	Value of Vector Base Register (VBR).....	86
5.8.3	Address Errors Caused by Stacking for Address Error Exception Handling.....	86
5.8.4	Notes on Slot Illegal Instruction Exception Handling.....	87
<b>Section 6 Interrupt Controller (INTC).....</b>		<b>89</b>
6.1	Features.....	89
6.2	Input/Output Pins.....	91
6.3	Register Descriptions.....	92
6.3.1	Interrupt Control Register 0 (ICR0).....	93
6.3.2	IRQ Control Register (IRQCR).....	94
6.3.3	IRQ Status register (IRQSR).....	96
6.3.4	Interrupt Priority Registers A to F and H to M (IPRA to IPRF and IPRH to IPRM).....	99
6.4	Interrupt Sources.....	102
6.4.1	External Interrupts.....	102
6.4.2	On-Chip Peripheral Module Interrupts.....	103
6.4.3	User Break Interrupt.....	103
6.5	Interrupt Exception Handling Vector Table.....	104
6.6	Interrupt Operation.....	107
6.6.1	Interrupt Sequence.....	107
6.6.2	Stack after Interrupt Exception Handling.....	110
6.7	Interrupt Response Time.....	110
6.8	Usage Note.....	112
<b>Section 7 User Break Controller (UBC).....</b>		<b>113</b>
7.1	Features.....	113
7.2	Register Descriptions.....	115
7.2.1	Break Address Register A (BARA).....	116
7.2.2	Break Address Mask Register A (BAMRA).....	116
7.2.3	Break Bus Cycle Register A (BBRA).....	117
7.2.4	Break Data Register A (BDRA).....	119
7.2.5	Break Data Mask Register A (BDMRA).....	120
7.2.6	Break Address Register B (BARB).....	121
7.2.7	Break Address Mask Register B (BAMRB).....	122
7.2.8	Break Data Register B (BDRB).....	123

7.2.9	Break Data Mask Register B (BDMRB).....	124
7.2.10	Break Bus Cycle Register B (BBRB) .....	125
7.2.11	Break Control Register (BRCR) .....	127
7.2.12	Execution Times Break Register (BETR).....	131
7.2.13	Branch Source Register (BRSR).....	132
7.2.14	Branch Destination Register (BRDR).....	133
7.3	Operation .....	134
7.3.1	Flow of the User Break Operation .....	134
7.3.2	Break on Instruction Fetch Cycle .....	135
7.3.3	Break on Data Access Cycle.....	135
7.3.4	Sequential Break.....	137
7.3.5	Value of Saved Program Counter .....	137
7.3.6	PC Trace .....	138
7.3.7	Usage Examples.....	139
7.4	Usage Notes .....	144
Section 8 Bus State Controller (BSC) .....		147
8.1	Features.....	147
8.2	Address Map.....	147
8.3	Access to on-chip FLASH and on-chip RAM .....	147
8.4	Access to on-chip Peripheral I/O Register .....	148
Section 9 Multi-Function Timer Pulse Unit 2 (MTU2).....		151
9.1	Features.....	151
9.2	Input/Output Pins .....	157
9.3	Register Descriptions.....	158
9.3.1	Timer Control Register (TCR).....	162
9.3.2	Timer Mode Register (TMDR).....	166
9.3.3	Timer I/O Control Register (TIOR).....	169
9.3.4	Timer Compare Match Clear Register (TCNTCMPCLR).....	188
9.3.5	Timer Interrupt Enable Register (TIER).....	189
9.3.6	Timer Status Register (TSR).....	194
9.3.7	Timer Buffer Operation Transfer Mode Register (TBTM).....	202
9.3.8	Timer Input Capture Control Register (TICCR).....	203
9.3.9	Timer A/D Converter Start Request Control Register (TADCR) .....	205
9.3.10	Timer A/D Converter Start Request Cycle Set Registers (TADCORA_4 and TADCORB_4).....	208
9.3.11	Timer A/D Converter Start Request Cycle Set Buffer Registers (TADCOBRA_4 and TADCOBRB_4) .....	208
9.3.12	Timer Counter (TCNT).....	209

9.3.13	Timer General Register (TGR) .....	209
9.3.14	Timer Start Register (TSTR) .....	210
9.3.15	Timer Synchronous Register (TSYR).....	212
9.3.16	Timer Read/Write Enable Register (TRWER) .....	214
9.3.17	Timer Output Master Enable Register (TOER) .....	215
9.3.18	Timer Output Control Register 1 (TOCR1) .....	216
9.3.19	Timer Output Control Register 2 (TOCR2) .....	219
9.3.20	Timer Output Level Buffer Register (TOLBR) .....	222
9.3.21	Timer Gate Control Register (TGCR) .....	223
9.3.22	Timer Subcounter (TCNTS) .....	225
9.3.23	Timer Dead Time Data Register (TDDR).....	226
9.3.24	Timer Cycle Data Register (TCDR) .....	226
9.3.25	Timer Cycle Buffer Register (TCBR).....	227
9.3.26	Timer Interrupt Skipping Set Register (TITCR) .....	227
9.3.27	Timer Interrupt Skipping Counter (TITCNT).....	229
9.3.28	Timer Buffer Transfer Set Register (TBTER) .....	230
9.3.29	Timer Dead Time Enable Register (TDER) .....	232
9.3.30	Timer Waveform Control Register (TWCR) .....	233
9.3.31	Bus Master Interface .....	234
9.4	Operation .....	235
9.4.1	Basic Functions.....	235
9.4.2	Synchronous Operation.....	241
9.4.3	Buffer Operation.....	243
9.4.4	Cascaded Operation .....	247
9.4.5	PWM Modes .....	252
9.4.6	Phase Counting Mode .....	257
9.4.7	Reset-Synchronized PWM Mode .....	264
9.4.8	Complementary PWM Mode.....	267
9.4.9	A/D Converter Start Request Delaying Function.....	308
9.4.10	External Pulse Width Measurement.....	312
9.4.11	Dead Time Compensation .....	313
9.4.12	TCNT Capture at Crest and/or Trough in Complementary PWM Operation .....	315
9.5	Interrupt Sources.....	316
9.5.1	Interrupt Sources and Priorities .....	316
9.5.2	A/D Converter Activation.....	319
9.6	Operation Timing.....	321
9.6.1	Input/Output Timing .....	321
9.6.2	Interrupt Signal Timing .....	328
9.7	Usage Notes .....	332
9.7.1	Module Standby Mode Setting .....	332

9.7.2	Input Clock Restrictions .....	332
9.7.3	Caution on Period Setting .....	333
9.7.4	Contention between TCNT Write and Clear Operations .....	333
9.7.5	Contention between TCNT Write and Increment Operations .....	334
9.7.6	Contention between TGR Write and Compare Match .....	335
9.7.7	Contention between Buffer Register Write and Compare Match .....	336
9.7.8	Contention between Buffer Register Write and TCNT Clear .....	337
9.7.9	Contention between TGR Read and Input Capture .....	338
9.7.10	Contention between TGR Write and Input Capture .....	339
9.7.11	Contention between Buffer Register Write and Input Capture .....	340
9.7.12	TCNT_2 Write and Overflow/Underflow Contention in Cascade Connection ....	340
9.7.13	Counter Value during Complementary PWM Mode Stop .....	342
9.7.14	Buffer Operation Setting in Complementary PWM Mode .....	342
9.7.15	Reset Sync PWM Mode Buffer Operation and Compare Match Flag .....	343
9.7.16	Overflow Flags in Reset Synchronous PWM Mode .....	344
9.7.17	Contention between Overflow/Underflow and Counter Clearing .....	345
9.7.18	Contention between TCNT Write and Overflow/Underflow .....	346
9.7.19	Cautions on Transition from Normal Operation or PWM Mode 1 to Reset-Synchronized PWM Mode .....	346
9.7.20	Output Level in Complementary PWM Mode and Reset-Synchronized PWM Mode .....	347
9.7.21	Interrupts in Module Standby Mode .....	347
9.7.22	Simultaneous Capture of TCNT_1 and TCNT_2 in Cascade Connection .....	347
9.8	MTU2 Output Pin Initialization .....	348
9.8.1	Operating Modes .....	348
9.8.2	Reset Start Operation .....	348
9.8.3	Operation in Case of Re-Setting Due to Error During Operation, etc. ....	349
9.8.4	Overview of Initialization Procedures and Mode Transitions in Case of Error during Operation, etc. ....	350
Section 10 Port Output Enable (POE) .....		381
10.1	Features .....	381
10.2	Input/Output Pins .....	383
10.3	Register Descriptions .....	384
10.3.1	Input Level Control/Status Register 1 (ICSR1) .....	385
10.3.2	Output Level Control/Status Register 1 (OCSR1) .....	388
10.3.3	Input Level Control/Status Register 3 (ICSR3) .....	389
10.3.4	Software Port Output Enable Register (SPOER) .....	391
10.3.5	Port Output Enable Control Register 1 (POECR1) .....	393
10.3.6	Port Output Enable Control Register 2 (POECR2) .....	394

10.4	Operation .....	396
10.4.1	Input Level Detection Operation .....	396
10.4.2	Output-Level Compare Operation .....	398
10.4.3	Release from High-Impedance State .....	398
10.5	Interrupts.....	399
10.6	Usage Note.....	400
10.6.1	Pin State when a Power-On Reset is Issued from the Watchdog Timer .....	400
Section 11 Watchdog Timer (WDT) .....		401
11.1	Features.....	401
11.2	Input/Output Pin for WDT .....	403
11.3	Register Descriptions .....	404
11.3.1	Watchdog Timer Counter (WTCNT).....	404
11.3.2	Watchdog Timer Control/Status Register (WTCSR).....	405
11.3.3	Notes on Register Access .....	407
11.4	Operation .....	408
11.4.1	Canceling Software Standbys .....	408
11.4.2	Using Watchdog Timer Mode .....	408
11.4.3	Using Interval Timer Mode .....	409
11.5	Usage Note.....	410
Section 12 Serial Communication Interface (SCI) .....		411
12.1	Features.....	411
12.2	Input/Output Pins .....	413
12.3	Register Descriptions .....	414
12.3.1	Receive Shift Register (SCRSR) .....	415
12.3.2	Receive Data Register (SCRDR) .....	415
12.3.3	Transmit Shift Register (SCTSR) .....	415
12.3.4	Transmit Data Register (SCTDR).....	416
12.3.5	Serial Mode Register (SCSMR).....	416
12.3.6	Serial Control Register (SCSCR).....	419
12.3.7	Serial Status Register (SCSSR) .....	422
12.3.8	Serial Port Register (SCSPTR) .....	428
12.3.9	Serial Direction Control Register (SCSDCR).....	430
12.3.10	Bit Rate Register (SCBRR) .....	431
12.4	Operation .....	442
12.4.1	Overview .....	442
12.4.2	Operation in Asynchronous Mode .....	444
12.4.3	Clock Synchronous Mode (Channel 1 in the SH7124 is not Available).....	454
12.4.4	Multiprocessor Communication Function .....	463

12.4.5	Multiprocessor Serial Data Transmission .....	465
12.4.6	Multiprocessor Serial Data Reception .....	466
12.5	SCI Interrupt Sources.....	469
12.6	Serial Port Register (SCSPTR) and SCI Pins .....	470
12.7	Usage Notes .....	471
12.7.1	SCTDR Writing and TDRE Flag .....	471
12.7.2	Multiple Receive Error Occurrence .....	471
12.7.3	Break Detection and Processing .....	472
12.7.4	Sending a Break Signal.....	472
12.7.5	Receive Data Sampling Timing and Receive Margin (Asynchronous Mode) .....	472
12.7.6	Note on Using External Clock in Clock Synchronous Mode.....	474
12.7.7	Module Standby Mode Setting .....	474
<b>Section 13 A/D Converter (ADC) .....</b>		<b>475</b>
13.1	Features.....	475
13.2	Input/Output Pins.....	477
13.3	Register Descriptions.....	478
13.3.1	A/D Data Registers 0 to 7 (ADDR0 to ADDR7).....	479
13.3.2	A/D Control/Status Registers_0 and _1 (ADCSR_0 and ADCSR_1) .....	479
13.3.3	A/D Control Registers_0 and _1 (ADCR_0 and ADCR_1) .....	482
13.3.4	A/D Trigger Select Register_0 (ADTSR_0).....	485
13.4	Operation .....	489
13.4.1	Single Mode.....	489
13.4.2	Continuous Scan Mode.....	489
13.4.3	Single-Cycle Scan Mode .....	490
13.4.4	Input Sampling and A/D Conversion Time .....	490
13.4.5	A/D Converter Activation by MTU2 .....	493
13.4.6	External Trigger Input Timing.....	493
13.4.7	2-Channel Scanning.....	494
13.5	Interrupt Sources.....	495
13.6	Definitions of A/D Conversion Accuracy.....	496
13.7	Usage Notes .....	499
13.7.1	Module Standby Mode Setting .....	499
13.7.2	Permissible Signal Source Impedance .....	499
13.7.3	Influences on Absolute Accuracy .....	499
13.7.4	Range of Analog Power Supply and Other Pin Settings.....	500
13.7.5	Notes on Board Design .....	500
13.7.6	Notes on Noise Countermeasures .....	501



Section 14	Compare Match Timer (CMT)	503
14.1	Features	503
14.2	Register Descriptions	504
14.2.1	Compare Match Timer Start Register (CMSTR)	505
14.2.2	Compare Match Timer Control/Status Register (CMCSR)	505
14.2.3	Compare Match Counter (CMCNT)	507
14.2.4	Compare Match Constant Register (CMCOR)	507
14.3	Operation	508
14.3.1	Interval Count Operation	508
14.3.2	CMCNT Count Timing	508
14.4	Interrupts	509
14.4.1	CMT Interrupt Sources	509
14.4.2	Timing of Setting Compare Match Flag	509
14.4.3	Timing of Clearing Compare Match Flag	509
14.5	Usage Notes	510
14.5.1	Module Standby Mode Setting	510
14.5.2	Conflict between Write and Compare-Match Processes of CMCNT	510
14.5.3	Conflict between Word-Write and Count-Up Processes of CMCNT	511
14.5.4	Conflict between Byte-Write and Count-Up Processes of CMCNT	512
14.5.5	Compare Match between CMCNT and CMCOR	512
Section 15	Pin Function Controller (PFC)	513
15.1	Register Descriptions	521
15.1.1	Port A I/O Register L (PAIORL)	522
15.1.2	Port A Control Registers L1 to L4 (PACRL1 to PACRL4)	522
15.1.3	Port B I/O Registers L and H (PBIORL and PBIORH)	533
15.1.4	Port B Control Registers L1, L2, and H1 (PBCRL1, PBCRL2, and PBCRH1)	534
15.1.5	Port E I/O Register L (PEIORL)	539
15.1.6	Port E Control Registers L1 to L4 (PECRL1 to PECRL4)	539
15.1.7	IRQOUT Function Control Register (IFCR)	549
15.2	Usage Notes	550
Section 16	I/O Ports	551
16.1	Port A	552
16.1.1	Register Descriptions	553
16.1.2	Port A Data Register L (PADRL)	553
16.1.3	Port A Port Register L (PAPRL)	557
16.2	Port B	559
16.2.1	Register Descriptions	559

16.2.2	Port B Data Registers H and L (PBDRH and PBDRL) .....	560
16.2.3	Port B Port Registers H and L (PBPRH and PBPRL) .....	563
16.3	Port E .....	566
16.3.1	Register Descriptions .....	568
16.3.2	Port E Data Register L (PEDRL) .....	568
16.3.3	Port E Port Register L (PEPRL) .....	571
16.4	Port F .....	573
16.4.1	Register Descriptions .....	573
16.4.2	Port F Data Register L (PFDRL) .....	574
<b>Section 17 Flash Memory .....</b>		<b>575</b>
17.1	Features .....	575
17.2	Overview .....	577
17.2.1	Block Diagram .....	577
17.2.2	Operating Mode .....	578
17.2.3	Mode Comparison .....	579
17.2.4	Flash Memory Configuration .....	580
17.2.5	Block Division .....	580
17.2.6	Programming/Erasing Interface .....	581
17.3	Input/Output Pins .....	583
17.4	Register Descriptions .....	583
17.4.1	Registers .....	583
17.4.2	Programming/Erasing Interface Registers .....	586
17.4.3	Programming/Erasing Interface Parameters .....	592
17.5	On-Board Programming Mode .....	607
17.5.1	Boot Mode .....	607
17.5.2	User Program Mode (Only in On-Chip 128-Kbyte and 64-Kbyte ROM Version) .....	611
17.6	Protection .....	620
17.6.1	Hardware Protection .....	620
17.6.2	Software Protection .....	621
17.6.3	Error Protection .....	621
17.7	Usage Notes .....	623
17.7.1	Interrupts during Programming/Erasing .....	623
17.7.2	Other Notes .....	625
17.8	Supplementary Information .....	627
17.8.1	Specifications of the Standard Serial Communications Interface in Boot Mode .....	627
17.8.2	Areas for Storage of the Procedural Program and Data for Programming .....	654
17.9	Off-Board Programming Mode .....	658

Section 18	RAM .....	659
18.1	Usage Notes .....	660
18.1.1	Module Standby Mode Setting .....	660
18.1.2	Address Error .....	660
18.1.3	Initial Values in RAM.....	660
Section 19	Power-Down Modes .....	661
19.1	Features.....	661
19.1.1	Types of Power-Down Modes .....	661
19.2	Input/Output Pins .....	663
19.3	Register Descriptions .....	663
19.3.1	Standby Control Register 1 (STBCR1).....	664
19.3.2	Standby Control Register 2 (STBCR2).....	665
19.3.3	Standby Control Register 3 (STBCR3).....	666
19.3.4	Standby Control Register 4 (STBCR4).....	667
19.3.5	Standby Control Register 5 (STBCR5).....	668
19.3.6	Standby Control Register 6 (STBCR6).....	669
19.3.7	RAM Control Register (RAMCR).....	670
19.4	Sleep Mode .....	671
19.4.1	Transition to Sleep Mode.....	671
19.4.2	Canceling Sleep Mode .....	671
19.5	Software Standby Mode.....	672
19.5.1	Transition to Software Standby Mode .....	672
19.5.2	Canceling Software Standby Mode .....	673
19.6	Module Standby Mode.....	674
19.6.1	Transition to Module Standby Mode .....	674
19.6.2	Canceling Module Standby Function.....	674
19.7	Usage Note.....	674
19.7.1	Current Consumption while Waiting for Oscillation to be Stabilized .....	674
19.7.2	Executing the SLEEP Instruction .....	674
Section 20	List of Registers .....	675
20.1	Register Address Table (In the Order from Lower Addresses).....	676
20.2	Register Bit List .....	684
20.3	Register States in Each Operating Mode .....	698
Section 21	Electrical Characteristics .....	707
21.1	Absolute Maximum Ratings .....	707
21.2	DC Characteristics .....	708
21.3	AC Characteristics .....	711

21.3.1	Clock Timing.....	712
21.3.2	Control Signal Timing.....	714
21.3.3	Multi Function Timer Pulse Unit 2 (MTU2) Timing.....	717
21.3.4	I/O Port Timing.....	719
21.3.5	Watchdog Timer (WDT) Timing.....	720
21.3.6	Serial Communication Interface (SCI) Timing.....	721
21.3.7	Port Output Enable (POE) Timing.....	723
21.3.8	A/D Converter Timing.....	724
21.3.9	Conditions for Testing AC Characteristics.....	725
21.4	A/D Converter Characteristics.....	726
21.5	Flash Memory Characteristics.....	727
21.6	Usage Note.....	728
21.6.1	Notes on Connecting V <sub>CL</sub> Capacitor.....	728
Appendix.....		729
A.	Pin States.....	729
B.	Product Code Lineup.....	733
C.	Package Dimensions.....	734
Main Revisions and Additions in this Edition.....		739
Index.....		745

# Section 1 Overview

## 1.1 Features of SH7125 and SH7124

This LSI is a single-chip RISC (Reduced Instruction Set Computer) microcomputer that integrates a Renesas Technology original RISC CPU core with peripheral functions required for system configuration.

The CPU in this LSI has a RISC-type instruction set. Most instructions can be executed in one state (one system clock cycle), which greatly improves instruction execution speed. In addition, the 32-bit internal-bus architecture enhances data processing power. With this CPU, it has become possible to assemble low-cost, high-performance, and high-functioning systems, even for applications that were previously impossible with microcomputers, such as real-time control, which demands high speeds.

In addition, this LSI includes on-chip peripheral functions necessary for system configuration, such as a ROM, a RAM, timers, a serial communication interface (SCI), an A/D converter, an interrupt controller (INTC), and I/O ports.

The version of the on-chip ROM is F-ZTAT™ (Flexible Zero Turn Around Time)\* that includes flash memory. The flash memory can be programmed with a programmer that supports programming of this LSI, and can also be programmed and erased by software. This enables LSI chip to be re-programmed at a user-site while mounted on a board.

The features of this LSI are listed in table 1.1.

Note: \* F-ZTAT™ is a trademark of Renesas Technology Corp.

**Table 1.1 Features**

Items	Specification
CPU	<ul style="list-style-type: none"> <li>• Central processing unit with an internal 32-bit RISC (Reduced Instruction Set Computer) architecture</li> <li>• Instruction length: 16-bit fixed length for improved code efficiency</li> <li>• Load-store architecture (basic operations are executed between registers)</li> <li>• Sixteen 32-bit general registers</li> <li>• Five-stage pipeline</li> <li>• On-chip multiplier: Multiplication operations (32 bits × 32 bits → 64 bits) executed in two to five cycles</li> <li>• C language-oriented 62 basic instructions</li> </ul> <p>Note: Some specifications on slot illegal instruction exception handling in this LSI differ from those of the conventional SH-2. For details, see section 5.8.4, Notes on Slot Illegal Instruction Exception Handling.</p>
Operating modes	<ul style="list-style-type: none"> <li>• Operating modes <ul style="list-style-type: none"> <li>— Single chip mode</li> </ul> </li> <li>• Operating states <ul style="list-style-type: none"> <li>— Program execution state</li> <li>— Exception handling state</li> </ul> </li> <li>• Power-down modes <ul style="list-style-type: none"> <li>— Sleep mode</li> <li>— Software standby mode</li> <li>— Module standby mode</li> </ul> </li> </ul>
User break controller (UBC)	<ul style="list-style-type: none"> <li>• Addresses, data values, type of access, and data size can all be set as break conditions</li> <li>• Supports a sequential break function</li> <li>• Two break channels</li> </ul>
On-chip ROM	<ul style="list-style-type: none"> <li>• 128 kbytes (SH71253, SH71243)</li> <li>• 64 kbytes (SH71252, SH71242)</li> <li>• 32 kbytes (SH71241)</li> </ul>
On-chip RAM	<ul style="list-style-type: none"> <li>• 8 kbytes</li> </ul>

---

<b>Items</b>	<b>Specification</b>
Interrupt controller (INTC)	<ul style="list-style-type: none"><li>• External interrupt pins<ul style="list-style-type: none"><li>— SH7125: Five pins (NMI and IRQ3 to IRQ0)</li><li>— SH7124: Four pins (NMI and IRQ3 to IRQ1)</li></ul></li><li>• On-chip peripheral interrupts: Priority level set for each module</li><li>• Vector addresses: A vector address for each interrupt source</li></ul>
User debugging interface (H-UDI)	<ul style="list-style-type: none"><li>• E10A emulator support</li></ul>
Clock pulse generator (CPG)	<ul style="list-style-type: none"><li>• Clock mode: Input clock can be selected from external input or crystal resonator</li><li>• Four types of clocks generated:<ul style="list-style-type: none"><li>— CPU clock: Maximum 50 MHz</li><li>— Bus clock: Maximum 40 MHz</li><li>— Peripheral clock: Maximum 40 MHz</li><li>— MTU2 clock: Maximum 40 MHz</li></ul></li></ul>
Watchdog timer (WDT)	<ul style="list-style-type: none"><li>• On-chip one-channel watchdog timer</li><li>• Interrupt generation is supported.</li></ul>

---

Items	Specification
Multi-function timer pulse unit 2 (MTU2)	<ul style="list-style-type: none"> <li>• Maximum 16 lines of pulse input/output and three lines of pulse input based on six channels of 16-bit timers (SH7125)</li> <li>• Maximum 12 lines of pulse input/output and three lines of pulse input based on six channels of 16-bit timers (SH7124)</li> <li>• 21 output compare and input capture registers</li> <li>• A total of 21 independent comparators</li> <li>• Selection of eight counter input clocks</li> <li>• Input capture function</li> <li>• Pulse output modes Toggle, PWM, complementary PWM, and reset-synchronized PWM modes</li> <li>• Synchronization of multiple counters</li> <li>• Complementary PWM output mode               <ul style="list-style-type: none"> <li>— Non-overlapping waveforms output for 6-phase inverter control</li> <li>— Automatic dead time setting</li> <li>— 0% to 100% PWM duty cycle specifiable</li> <li>— Output suppression</li> <li>— A/D conversion delaying function</li> <li>— Dead time compensation</li> <li>— Interrupt skipping at crest or trough</li> </ul> </li> <li>• Reset-synchronized PWM mode Three-phase PWM waveforms in positive and negative phases can be output with a required duty cycle</li> <li>• Phase counting mode Two-phase encoder pulse counting available</li> </ul>
Port output enable (POE)	<ul style="list-style-type: none"> <li>• High-impedance control of waveform output pins and channel 0 pins in MTU2</li> </ul>
Compare match timer (CMT)	<ul style="list-style-type: none"> <li>• 16-bit counters</li> <li>• Compare match interrupts can be generated</li> <li>• Two channels</li> </ul>
Serial communication interface (SCI)	<ul style="list-style-type: none"> <li>• Clock synchronous or asynchronous mode</li> <li>• Three channels</li> </ul>



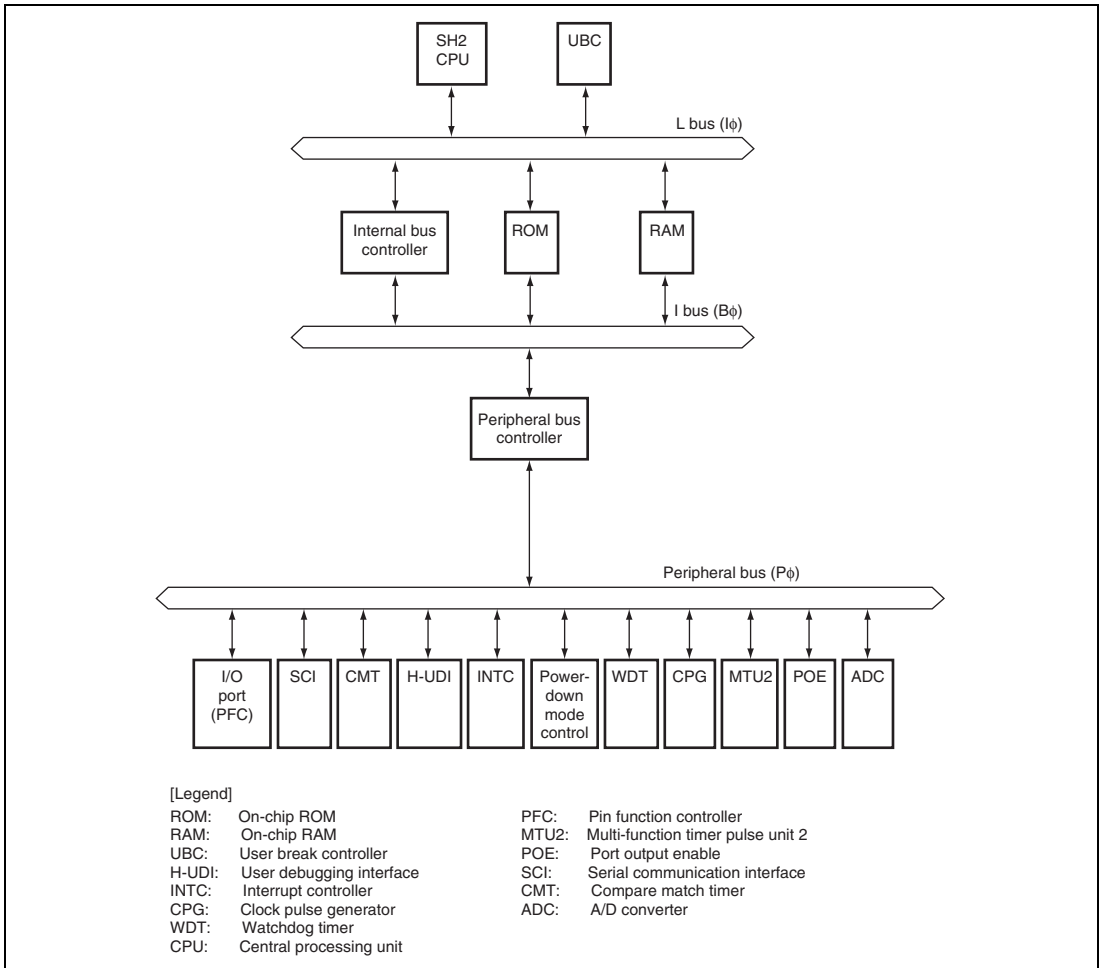
---

<b>Items</b>	<b>Specification</b>
A/D converter (ADC)	<ul style="list-style-type: none"><li>• 10 bits × 8 channels</li><li>• Conversion request by external triggers or MTU2</li><li>• Two sample-and-hold function units (two channels can be sampled simultaneously)</li></ul>
I/O ports	<ul style="list-style-type: none"><li>• 37 general input/output pins and eight general input pins (SH7125)</li><li>• 23 general input/output pins and eight general input pins (SH7124)</li><li>• Input or output can be selected for each bit</li></ul>
Packages	<ul style="list-style-type: none"><li>• QFP-64 (0.8 pitch) (SH7125)</li><li>• LQFP-64 (0.5 pitch) (SH7125)</li><li>• LQFP-48 (0.65 pitch) (SH7124)</li><li>• VQFN-64 (0.4 pitch) (SH7125)</li><li>• VQFN-52 (0.4 pitch) (SH7124)</li></ul>
Power supply voltage	<ul style="list-style-type: none"><li>• V<sub>cc</sub>: 4.0 to 5.5 V</li><li>• AV<sub>cc</sub>: 4.0 to 5.5 V</li></ul>

---

## 1.2 Block Diagram

The block diagram of this LSI is shown in figure 1.1.



**Figure 1.1 Block Diagram**

### 1.3 Pin Assignments

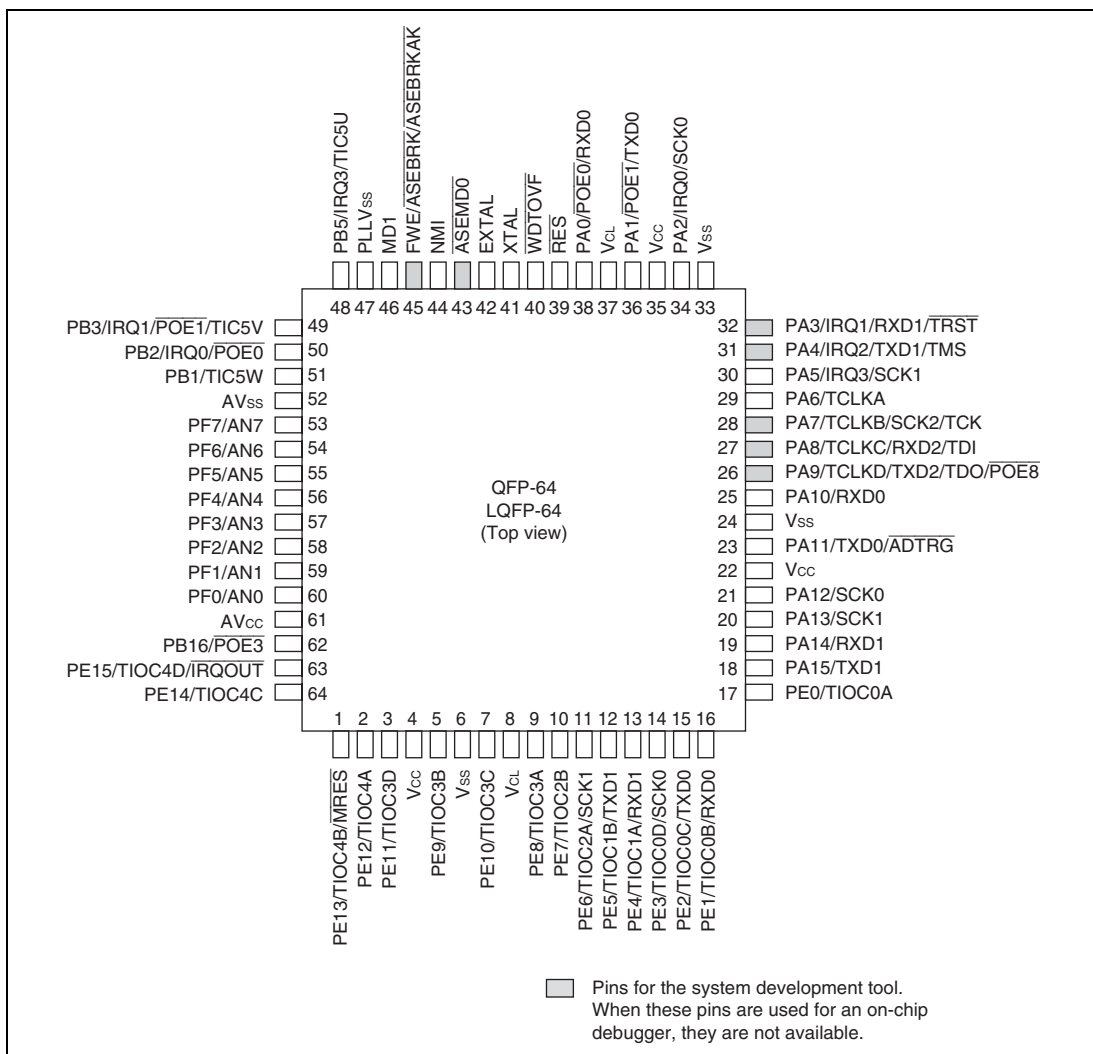


Figure 1.2 (1) Pin Assignments of SH7125

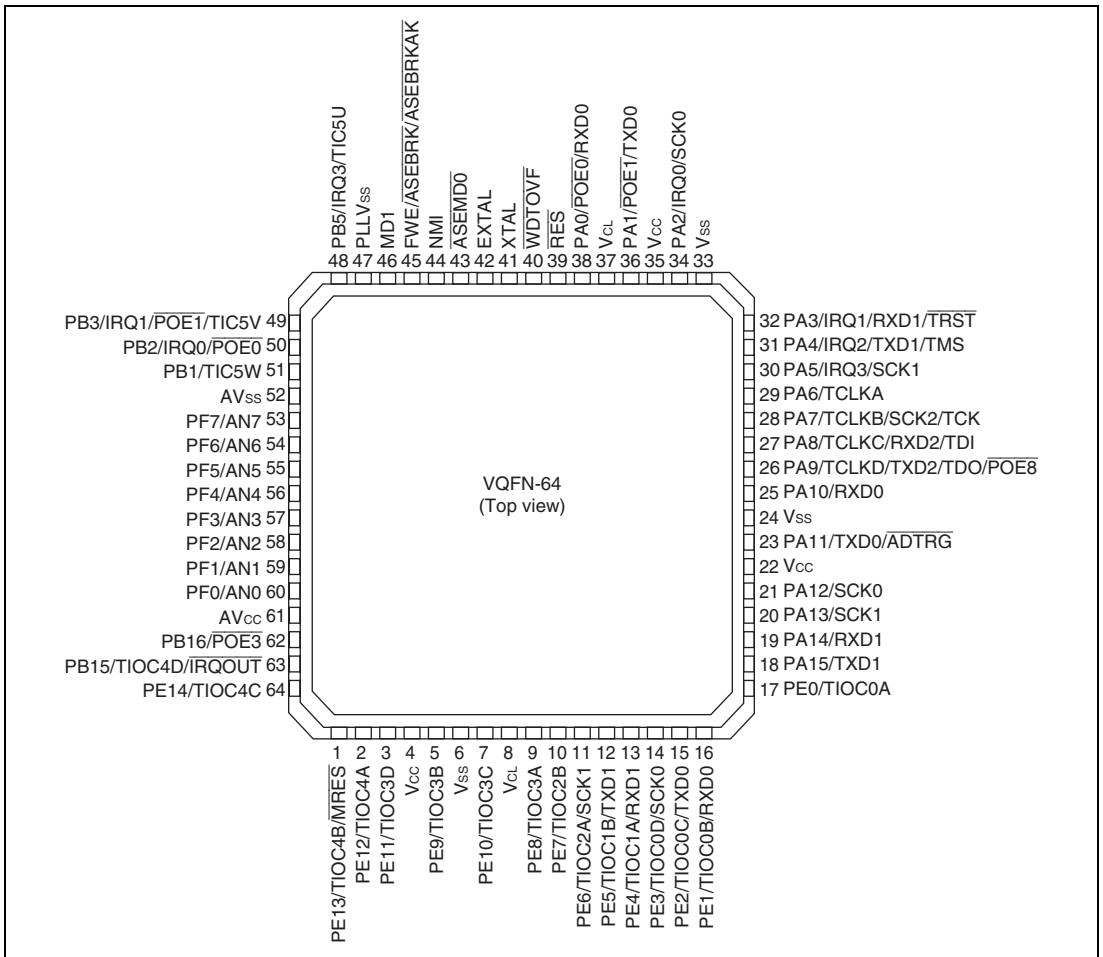
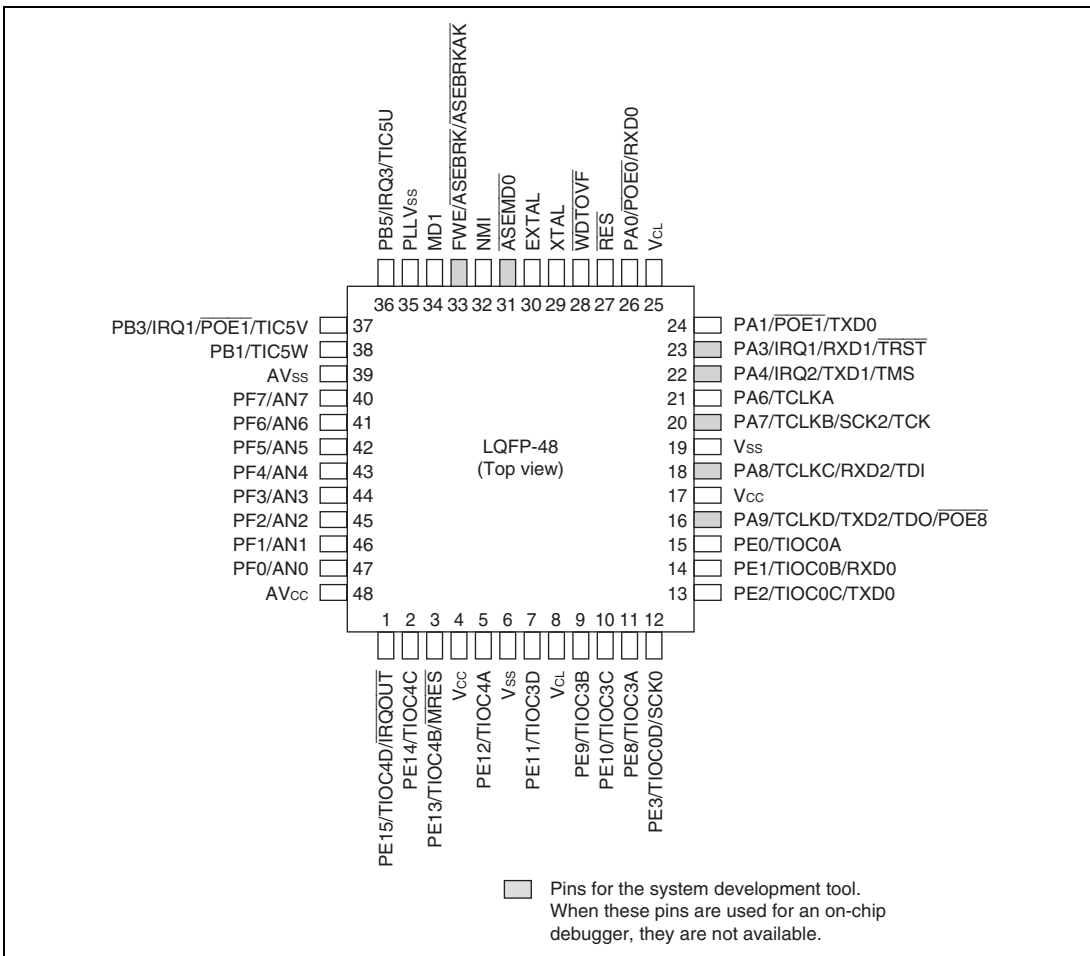


Figure 1.2 (2) Pin Assignments of SH7125



**Figure 1.3 (1) Pin Assignments of SH7124**

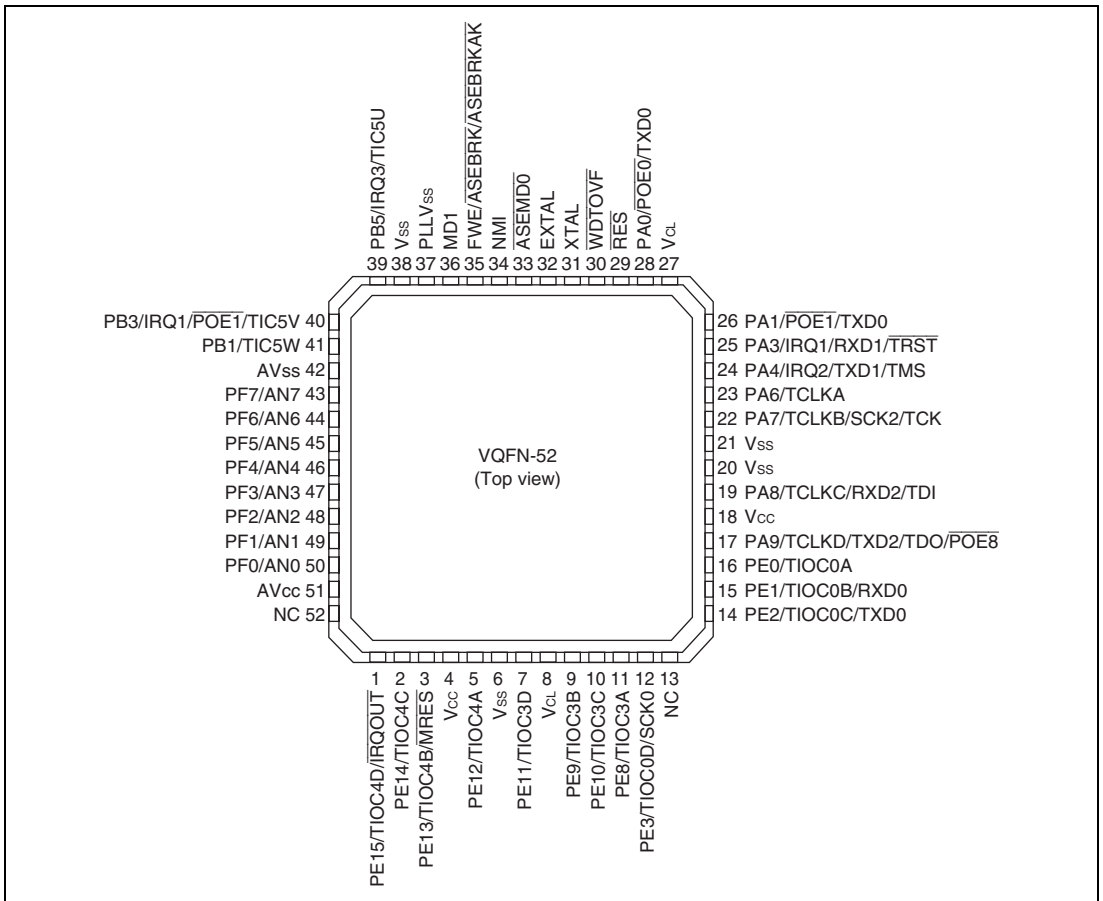


Figure 1.3 (2) Pin Assignments of SH7124

## 1.4 Pin Functions

Table 1.2 summarizes the pin functions.

**Table 1.2 Pin Functions**

Classification	Symbol	I/O	Name	Function
Power supply	Vcc	I	Power supply	Power supply pin Connect all Vcc pins to the system. There will be no operation if any pins are open.
	Vss	I	Ground	Ground pin Connect all Vss pins to the system power supply (0V). There will be no operation if any pins are open.
	VCL	O	Power supply for internal power-down	External capacitance pins for internal power-down power supply Connect these pins to Vss via a 0.1 to 0.47 $\mu$ F capacitor (placed close to the pins).
Clock	PLLvss	I	PLL ground	Ground pin for the on-chip PLL oscillator
	EXTAL	I	External clock	Connected to a crystal resonator. An external clock signal may also be input to the EXTAL pin.
	XTAL	O	Crystal	Connected to a crystal resonator.
Operating mode control	MD1	I	Mode set	Sets the operating mode. Do not change values on this pin during operation.
	FWE	I	Flash memory write enable	Pin for flash memory Flash memory can be protected against programming or erasure through this pin.

Classification	Symbol	I/O	Name	Function
System control	$\overline{\text{RES}}$	I	Power-on reset	When low, this LSI enters the power-on reset state.
	$\overline{\text{MRES}}$	I	Manual reset	When low, this LSI enters the manual reset state.
	$\overline{\text{WDTOVF}}$	O	Watchdog timer overflow	Output signal for the watchdog timer overflow  If this pin needs to be pulled down, use the resistor larger than 1 M $\Omega$ to pull this pin down.
Interrupts	NMI	I	Non-maskable interrupt	Non-maskable interrupt request pin  Fix to high or low level when not in use.
	IRQ3 to IRQ0 (SH7125) IRQ3 to IRQ1 (SH7124)	I	Interrupt requests 3 to 0	Maskable interrupt request pins  Selectable as level input or edge input. The rising edge, falling edge, and both edges are selectable as edges.
	$\overline{\text{IRQOUT}}$	O	Interrupt request output	Shows that an interrupt cause has occurred. The interrupt cause can be recognized even in the bus release state.
Multi function timer-pulse unit 2 (MTU2)	TCLKA, TCLKB, TCLKC, TCLKD	I	MTU2 timer clock input	External clock input pins for the timer
	TIOC0A, TIOC0B, TIOC0C, TIOC0D	I/O	MTU2 input capture/output compare (channel 0)	The TGRA_0 to TGRD_0 input capture input/output compare output/PWM output pins
	TIOC1A, TIOC1B (only in SH7125)	I/O	MTU2 input capture/output compare (channel 1)	The TGRA_1 to TGRB_1 input capture input/output compare output/PWM output pins
	TIOC2A, TIOC2B (only in SH7125)	I/O	MTU2 input capture/output compare (channel 2)	The TGRA_2 to TGRB_2 input capture input/output compare output/PWM output pins



Classification	Symbol	I/O	Name	Function
Multi function timer-pulse unit 2 (MTU2)	TIOC3A, TIOC3B, TIOC3C, TIOC3D	I/O	MTU2 input capture/output compare (channel 3)	The TGRA_3 to TGRD_3 input capture input/output compare output/PWM output pins
	TIOC4A, TIOC4B, TIOC4C, TIOC4D	I/O	MTU2 input capture/output compare (channel 4)	The TGRA_4 to TGRD_4 input capture input/output compare output/PWM output pins
	TIC5U, TIC5V, TIC5W	I	MTU2 input capture (channel 5)	The TGRU_5, TGRV_5, and TGRW_5 input capture input pins
Port output enable (POE)	POE8, POE3, POE1, POE0 (SH7125)	I	Port output enable	Request signal input to place the waveform output pins and channel 0 pins of MTU2 in high impedance state.
	POE8, POE1, POE0 (SH7124)			In the SH7125, while POE3 function is selected in the PFC, the pin is pulled up inside this LSI if no signals are input to them.
Serial communication interface (SCI)	TXD2 to TXD0	O	Transmit data	Transmit data output pins
	RXD2 to RXD0	I	Receive data	Receive data input pins
	SCK2 to SCK0 (SH7125) SCK2, SCK0 (SH7124)	I/O	Serial clock	Clock input/output pins
A/D converter (ADC)	AN7 to AN0	I	Analog input pins	Analog input pins
	ADTRG (only in SH7125)	I	A/D conversion trigger input	External trigger input pin for starting A/D conversion
	AVcc	I	Analog power supply	Power supply pin for the A/D converter  Connect all AVcc pins to the system power supply (Vcc) when the A/D converter is not used. The A/D converter does not work if any pin is open.

Classification	Symbol	I/O	Name	Function
A/D converter	AVss	I	Analog ground	Ground pin for the A/D converter Connect it to the system ground (0 V).  Connect all AVss pins to the system ground (0 V) correctly. The A/D converter does not work if any pin is open.
I/O ports	PA15 to PA0 (SH7125)	I/O	General port	16-bit input/output port pins
	PA9 to PA6, PA4, PA3, PA1, PA0 (SH7124)			8-bit input/output port pins
	PB16, PB5, PB3 to PB1 (SH7125)	I/O	General port	5-bit input/output port pins
	PB5, PB3, PB1 (SH7124)			3-bit input/output port pins
	PE15 to PE0 (SH7125)	I/O	General port	16-bit input/output port pins
	PE15 to PE8, PE3 to PE0 (SH7124)			12-bit input/output port pins
	PF7 to PF0	I	General port	8-bit input port pins
User debugging interface (H-UDI)	TCK	I	Test clock	Test-clock input pin
	TMS	I	Test mode select	Inputs the test-mode select signal.
	TDI	I	Test data input	Serial input pin for instructions and data
	TDO	O	Test data output	Serial output pin for instructions and data
	TRST	I	Test reset	Initialization-signal input pin

Classification	Symbol	I/O	Name	Function
E10A interface	$\overline{\text{ASEMD0}}$	I	ASE mode	Sets the ASE mode.  When a low level is input, this LSI enters ASE mode. When a high level is input, this LSI enters the normal mode. The emulator functions are available in ASE mode. When no signal is input, this pin is pulled up inside this LSI.
	$\overline{\text{ASEBRK}}$	I	Break request	E10A emulator break input pin
	$\overline{\text{ASEBRKAK}}$	O	Break mode acknowledge	Indicates that the E10A emulator has entered its break mode.

Note: The  $\overline{\text{WDTOVF}}$  pin should not be pulled down. When absolutely necessary, pull it down through a resistor of 1 M $\Omega$  or larger.



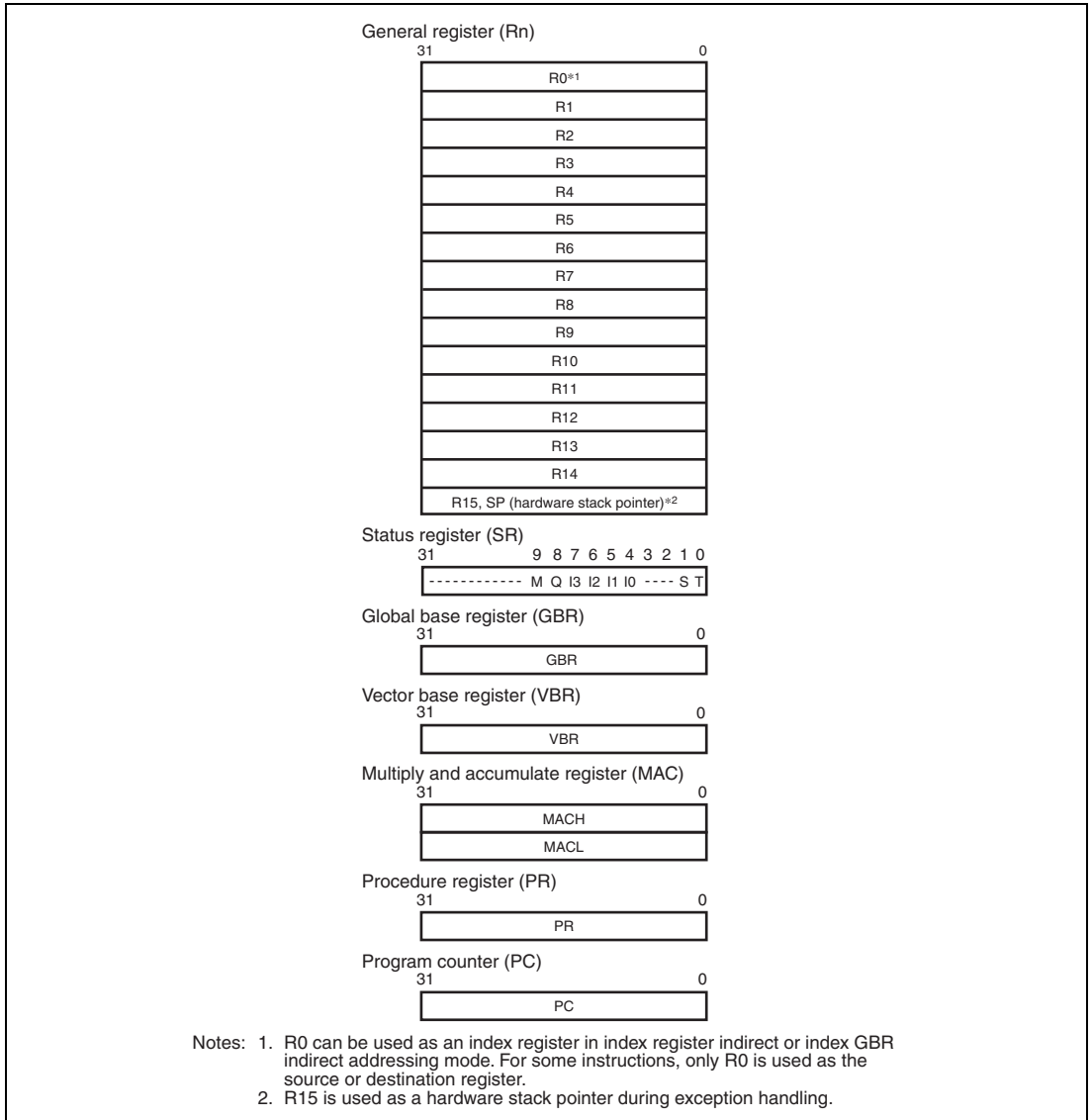
## Section 2 CPU

### 2.1 Features

- General registers: 32-bit register × 16
- Basic instructions: 62
- Addressing modes: 11
  - Register direct (Rn)
  - Register indirect (@Rn)
  - Post-increment register indirect (@Rn+)
  - Pre-decrement register indirect (@-Rn)
  - Register indirect with displacement (@disp:4, Rn)
  - Index register indirect (@R0, Rn)
  - GBR indirect with displacement (@disp:8, GBR)
  - Index GBR indirect (@R0, GBR)
  - PC relative with displacement (@disp:8, PC)
  - PC relative (disp:8/disp:12/Rn)
  - Immediate (#imm:8)

## 2.2 Register Configuration

There are three types of registers: general registers (32-bit  $\times$  16), control registers (32-bit  $\times$  3), and system registers (32-bit  $\times$  4).



**Figure 2.1 CPU Internal Register Configuration**

## 2.2.1 General Registers (Rn)

There are sixteen 32-bit general registers (Rn), designated R0 to R15. The general registers are used for data processing and address calculation. R0 is also used as an index register. With a number of instructions, R0 is the only register that can be used. R15 is used as a hardware stack pointer (SP). In exception handling, R15 is used for accessing the stack to save or restore the status register (SR) and program counter (PC) values.

## 2.2.2 Control Registers

There are three 32-bit control registers, designated status register (SR), global base register (GBR), and vector base register (VBR). SR indicates a processing state. GBR is used as a base address in GBR indirect addressing mode for data transfer of on-chip peripheral module registers. VBR is used as a base address of the exception handling (including interrupts) vector table.

- Status register (SR)

Bit:	31	30	29	28	27	26	25	24	23	22	21	20	19	18	17	16
	-	-	-	-	-	-	-	-	-	-	-	-	-	-	-	-
Initial value:	0	0	0	0	0	0	0	0	0	0	0	0	0	0	0	0
R/W:	R	R	R	R	R	R	R	R	R	R	R	R	R	R	R	R
Bit:	15	14	13	12	11	10	9	8	7	6	5	4	3	2	1	0
	-	-	-	-	-	-	M	Q	I[3:0]				-	-	S	T
Initial value:	0	0	0	0	0	0	-	-	1	1	1	1	0	0	-	-
R/W:	R	R	R	R	R	R	R/W	R/W	R/W	R/W	R/W	R/W	R	R	R/W	R/W

Bit	Bit name	Default	Read/Write	Description
31 to 10	—	All 0	R	Reserved These bits are always read as 0. The write value should always be 0.
9	M	Undefined	R/W	Used by the DIV0U, DIV0S, and DIV1 instructions.
8	Q	Undefined	R/W	Used by the DIV0U, DIV0S, and DIV1 instructions.
7 to 4	I[3:0]	1111	R/W	Interrupt Mask
3, 2	—	All 0	R	Reserved These bits are always read as 0. The write value should always be 0.

Bit	Bit name	Default	Read/Write	Description
1	S	Undefined	R/W	S Bit Used by the multiply and accumulate instruction.
0	T	Undefined	R/W	T Bit Indicates true (1) or false (0) in the following instructions: MOVT, CMP/cond, TAS, TST, BT (BT/S), BF (BF/S), SETT, CLRT Indicates carry, borrow, overflow, or underflow in the following instructions: ADDV, ADDC, SUBV, SUBC, NEGC, DIV0U, DIV0S, DIV1, SHAR, SHAL, SHLR, SHLL, ROTR, ROTL, ROTCR, ROTCL

- Global-base register (GBR)  
This register indicates a base address in GBR indirect addressing mode. The GBR indirect addressing mode is used for data transfer of the on-chip peripheral module registers and logic operations.
- Vector-base register (VBR)  
This register indicates the base address of the exception handling vector table.



### 2.2.3 System Registers

There are four 32-bit system registers, designated two multiply and accumulate registers (MACH and MACL), a procedure register (PR), and program counter (PC).

- Multiply and accumulate registers (MACH and MACL)  
This register stores the results of multiplication and multiply-and-accumulate operation.
- Procedure register (PR)  
This register stores the return-destination address from subroutine procedures.
- Program counter (PC)  
The PC indicates the point which is four bytes (two instructions) after the current execution instruction.

### 2.2.4 Initial Values of Registers

Table 2.1 lists the initial values of registers after a reset.

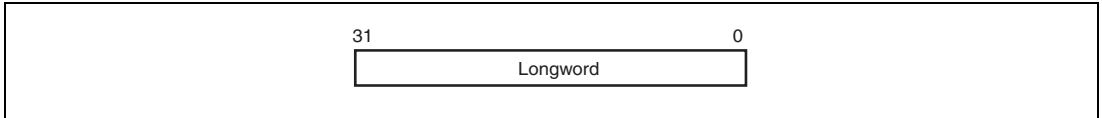
**Table 2.1 Initial Values of Registers**

Type of register	Register	Default
General register	R0 to R14	Undefined
	R15 (SP)	SP value set in the exception handling vector table
Control register	SR	I3 to I0: 1111 (H'F) Reserved bits: 0 Other bits: Undefined
	GBR	Undefined
	VBR	H'00000000
System register	MACH, MACL, PR	Undefined
	PC	PC value set in the exception handling vector table

## 2.3 Data Formats

### 2.3.1 Register Data Format

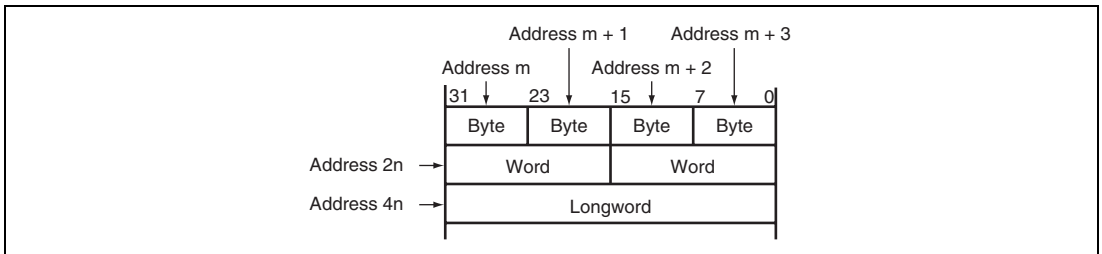
The size of register operands is always longwords (32 bits). When loading byte (8 bits) or word (16 bits) data in memory into a register, the data is sign-extended to longword and stored in the register.



**Figure 2.2 Register Data Format**

### 2.3.2 Memory Data Formats

Memory data formats are classified into bytes, words, and longwords. Byte data can be accessed from any address. Locate, however, word data at an address  $2n$ , longword data at  $4n$ . Otherwise, an address error will occur if an attempt is made to access word data starting from an address other than  $2n$  or longword data starting from an address other than  $4n$ . In such cases, the data accessed cannot be guaranteed. The hardware stack area, pointed by the hardware stack pointer (SP, R15), uses only longword data starting from address  $4n$  because this area holds the program counter and status register.



**Figure 2.3 Memory Data Format**

### 2.3.3 Immediate Data Formats

Immediate data of eight bits is placed in the instruction code.

For the MOV, ADD, and CMP/EQ instructions, the immediate data is sign-extended to longword and then calculated. For the TST, AND, OR, and XOR instructions, the immediate data is zero-extended to longword and then calculated. Thus, if the immediate data is used for the AND instruction, the upper 24 bits in the destination register are always cleared.

The immediate data of word or longword is not placed in the instruction code. It is placed in a table in memory. The table in memory is accessed by the MOV immediate data instruction in PC relative addressing mode with displacement.

## 2.4 Features of Instructions

### 2.4.1 RISC Type

The instructions are RISC-type instructions with the following features:

**Fixed 16-Bit Length:** All instructions have a fixed length of 16 bits. This improves program code efficiency.

**One Instruction per Cycle:** Since pipelining is used, basic instructions can be executed in one cycle.

**Data Size:** The basic data size for operations is longword. Byte, word, or longword can be selected as the memory access size. Byte or word data in memory is sign-extended to longword and then calculated. Immediate data is sign-extended to longword for arithmetic operations or zero-extended to longword size for logical operations.

**Table 2.2 Word Data Sign Extension**

CPU in this LSI	Description	Example of Other CPUs
MOV.W @ (disp,PC),R1	Sign-extended to 32 bits, R1 becomes H'00001234, and is then operated on by the ADD instruction.	ADD.W #H'1234,R0
ADD R1,R0		
.....		
.DATA.W H'1234		

Note: \* Immediate data is accessed by @ (disp,PC).

**Load/Store Architecture:** Basic operations are executed between registers. In operations involving memory, data is first loaded into a register (load/store architecture). However, bit manipulation instructions such as AND are executed directly in memory.

**Delayed Branching:** Unconditional branch instructions means the delayed branch instructions. With a delayed branch instruction, the branch is made after execution of the instruction immediately following the delayed branch instruction. This minimizes disruption of the pipeline when a branch is made. The conditional branch instructions have two types of instructions: conditional branch instructions and delayed branch instructions.

**Table 2.3 Delayed Branch Instructions**

CPU in this LSI		Description	Example of Other CPUs
BRA	TRGET	ADD is executed before branch to TRGET.	ADD.W R1,R0
ADD	R1,R0		BRA TRGET

**Multiply/Multiply-and-Accumulate Operations:** A  $16 \times 16 \rightarrow 32$  multiply operation is executed in one to two cycles, and a  $16 \times 16 + 64 \rightarrow 64$  multiply-and-accumulate operation in two to three cycles. A  $32 \times 32 \rightarrow 64$  multiply operation and a  $32 \times 32 + 64 \rightarrow 64$  multiply-and-accumulate operation are each executed in two to four cycles.

**T Bit:** The result of a comparison is indicated by the T bit in SR, and a conditional branch is performed according to whether the result is True or False. Processing speed has been improved by keeping the number of instructions that modify the T bit to a minimum.

**Table 2.4 T Bit**

CPU in this LSI		Description	Example of Other CPUs
CMP/GE	R1,R0	When $R0 \geq R1$ , the T bit is set.	CMP.W R1,R0
BT	TRGET0	When $R0 \geq R1$ , a branch is made to TRGET0.	BGE TRGET0
BF	TRGET1	When $R0 < R1$ , a branch is made to TRGET1.	BLT TRGET1
ADD	#1,R0	The T bit is not changed by ADD.	SUB.W #1,R0
CMP/EQ	#0,R0	When $R0 = 0$ , the T bit is set.	BEQ TRGET
BT	TRGET	A branch is made when $R0 = 0$ .	

**Immediate Data:** 8-bit immediate data is placed in the instruction code. Word and longword immediate data is not placed in the instruction code. It is placed in a table in memory. The table in memory is accessed with the MOV immediate data instruction using PC relative addressing mode with displacement.

**Table 2.5 Access to Immediate Data**

Type	This LSI's CPU	Example of Other CPU
8-bit immediate	MOV #H'12,R0	MOV.B #H'12,R0
16-bit immediate	MOV.W @(disp,PC),R0 ..... .DATA.W H'1234	MOV.W #H'1234,R0
32-bit immediate	MOV.L @(disp,PC),R0 ..... .DATA.L H'12345678	MOV.L #H'12345678,R0

Note: \* Immediate data is accessed by @(disp,PC).

**Absolute Addresses:** When data is accessed by absolute address, place the absolute address value in a table in memory beforehand. The absolute address value is transferred to a register using the method whereby immediate data is loaded when an instruction is executed, and the data is accessed using the register indirect addressing mode.

**Table 2.6 Access to Absolute Address**

Type	CPU in this LSI	Example of Other CPUs
Absolute address	MOV.L @(disp,PC),R1 MOV.B @R1,R0 ..... .DATA.L H'12345678	MOV.B @H'12345678,R0

Note: \* Immediate data is referenced by @(disp,PC).

**16-Bit/32-Bit Displacement:** When data is accessed using the 16- or 32-bit displacement addressing mode, the displacement value is placed in a table in memory beforehand. Using the method whereby immediate data is loaded when an instruction is executed, this value is transferred to a register and the data is accessed using index register indirect addressing mode.

**Table 2.7 Access with Displacement**

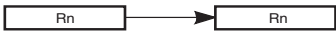
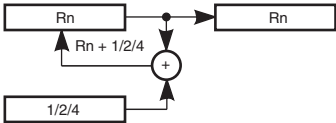
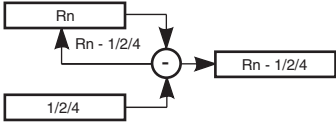
Type	CPU in this LSI	Example of Other CPUs
16-bit displacement	MOV.W @(disp,PC),R0 MOV.W @(R0,R1),R2 ..... .DATA.W H'1234	MOV.W @(H'1234,R1),R2

Note: \* Immediate data is referenced by @(disp,PC).

## 2.4.2 Addressing Modes

Table 2.8 lists addressing modes and effective address calculation methods.

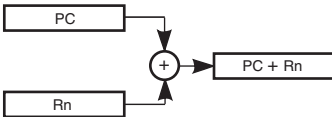
**Table 2.8 Addressing Modes and Effective Addresses**

Addressing Mode	Instruction Format	Effective Address Calculation Method	Calculation Formula
Register direct	Rn	Effective address is register Rn. (Operand is register Rn contents.)	—
Register indirect	@Rn	Effective address is register Rn contents. 	Rn
Register indirect with post-increment	@Rn+	Effective address is register Rn contents. A constant is added to Rn after instruction execution: 1 for a byte operand, 2 for a word operand, 4 for a longword operand. 	Rn After instruction execution Byte: $Rn + 1 \rightarrow Rn$ Word: $Rn + 2 \rightarrow Rn$ Longword: $Rn + 4 \rightarrow Rn$
Register indirect with pre-decrement	@-Rn	Effective address is register Rn contents, decremented by a constant beforehand: 1 for a byte operand, 2 for a word operand, 4 for a longword operand. 	Byte: $Rn - 1 \rightarrow Rn$ Word: $Rn - 2 \rightarrow Rn$ Longword: $Rn - 4 \rightarrow Rn$ (Instruction executed with Rn after calculation)

Addressing Mode	Instruction Format	Effective Address Calculation Method	Calculation Formula
Register indirect with displacement	@(disp:4, Rn)	Effective address is register Rn contents with 4-bit displacement disp added. After disp is zero-extended, it is multiplied by 1 (byte), 2 (word), or 4 (longword), according to the operand size.	Byte: $Rn + disp$ Word: $Rn + disp \times 2$ Longword: $Rn + disp \times 4$
Index register indirect	@(R0, Rn)	Effective address is sum of register Rn and R0 contents.	$Rn + R0$
GBR indirect with displacement	@(disp:8, GBR)	Effective address is register GBR contents with 8-bit displacement disp added. After disp is zero-extended, it is multiplied by 1 (byte), 2 (word), or 4 (longword), according to the operand size.	Byte: $GBR + disp$ Word: $GBR + disp \times 2$ Longword: $GBR + disp \times 4$
Index GBR indirect	@(R0, GBR)	Effective address is sum of register GBR and R0 contents.	$GBR + R0$

Addressing Mode	Instruction Format	Effective Address Calculation Method	Calculation Formula
PC relative with displacement	@(disp:8, PC)	Effective address is PC with 8-bit displacement disp added. After disp is zero-extended, it is multiplied by 2 (word) or 4 (longword), according to the operand size. With a longword operand, the lower 2 bits of PC are masked.	Word: $PC + disp \times 2$ Longword: $PC \& H'FFFFFFC + disp \times 4$
		<p style="text-align: center;">*With longword operand</p>	
PC relative	disp:8	Effective address is PC with 8-bit displacement disp added after being sign-extended and multiplied by 2.	$PC + disp \times 2$
	disp:12	Effective address is PC with 12-bit displacement disp added after being sign-extended and multiplied by 2.	$PC + disp \times 2$



Addressing Mode	Instruction Format	Effective Address Calculation Method	Calculation Formula
PC relative	Rn	Effective address is sum of PC and Rn. 	PC + Rn
Immediate	#imm:8	8-bit immediate data imm of TST, AND, OR, or XOR instruction is zero-extended.	—
	#imm:8	8-bit immediate data imm of MOV, ADD, or CMP/EQ instruction is sign-extended.	—
	#imm:8	8-bit immediate data imm of TRAPA instruction is zero-extended and multiplied by 4.	—

### 2.4.3 Instruction Formats

This section describes the instruction formats, and the meaning of the source and destination operands. The meaning of the operands depends on the instruction code. The following symbols are used in the table.

xxxx: Instruction code

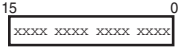
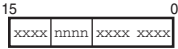
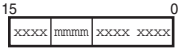
mmmm: Source register

nnnn: Destination register

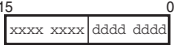
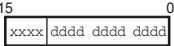
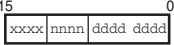
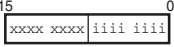
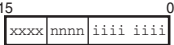
iiii: Immediate data

dddd: Displacement

**Table 2.9 Instruction Formats**

Instruction Format	Source Operand	Destination Operand	Sample Instruction
0 type 	—	—	NOP
n type 	—	nnnn: register direct	MOVT Rn
	Control register or system register	nnnn: register direct	STS MACH,Rn
	Control register or system register	nnnn: pre-decrement register indirect	STC.L SR,@-Rn
m type 	mmmm: register direct	Control register or system register	LDC Rm,SR
	mmmm: post-increment register indirect	Control register or system register	LDC.L @Rm+,SR
	mmmm: register indirect	—	JMP @Rm
	PC relative using Rm	—	BRAF Rm

Instruction Format	Source Operand	Destination Operand	Sample Instruction				
nm type <div style="border: 1px solid black; padding: 2px; margin-top: 5px;"> <span style="float: left;">15</span> <span style="float: right;">0</span> <table style="width: 100%; border-collapse: collapse;"> <tr> <td style="border: 1px solid black; width: 25%;">xxxx</td> <td style="border: 1px solid black; width: 25%;">nnnn</td> <td style="border: 1px solid black; width: 25%;">mmmm</td> <td style="border: 1px solid black; width: 25%;">xxxx</td> </tr> </table> </div>	xxxx	nnnn	mmmm	xxxx	mmmmn: register direct	nnnn: register direct	ADD Rm,Rn
xxxx	nnnn	mmmm	xxxx				
	mmmmn: register direct	nnnn: register indirect	MOV.L Rm,@Rn				
	mmmmn: post-increment register indirect (multiply-and-accumulate operation)  nnnn: * post-increment register indirect (multiply-and-accumulate operation)	MACH, MACL	MAC.W @Rm+,@Rn+				
	mmmmn: post-increment register indirect	nnnn: register direct	MOV.L @Rm+,Rn				
	mmmmn: register direct	nnnn: pre-decrement register indirect	MOV.L Rm,@-Rn				
	mmmmn: register direct	nnnn: index register indirect	MOV.L Rm,@(R0,Rn)				
md type <div style="border: 1px solid black; padding: 2px; margin-top: 5px;"> <span style="float: left;">15</span> <span style="float: right;">0</span> <table style="width: 100%; border-collapse: collapse;"> <tr> <td style="border: 1px solid black; width: 25%;">xxxx</td> <td style="border: 1px solid black; width: 25%;">xxxx</td> <td style="border: 1px solid black; width: 25%;">mmmm</td> <td style="border: 1px solid black; width: 25%;">dddd</td> </tr> </table> </div>	xxxx	xxxx	mmmm	dddd	mmmmdddd: register indirect with displacement	R0 (register direct)	MOV.B @(disp,Rm),R0
xxxx	xxxx	mmmm	dddd				
nd4 type <div style="border: 1px solid black; padding: 2px; margin-top: 5px;"> <span style="float: left;">15</span> <span style="float: right;">0</span> <table style="width: 100%; border-collapse: collapse;"> <tr> <td style="border: 1px solid black; width: 25%;">xxxx</td> <td style="border: 1px solid black; width: 25%;">xxxx</td> <td style="border: 1px solid black; width: 25%;">nnnn</td> <td style="border: 1px solid black; width: 25%;">dddd</td> </tr> </table> </div>	xxxx	xxxx	nnnn	dddd	R0 (register direct)	nnnndddd: register indirect with displacement	MOV.B R0,@(disp,Rn)
xxxx	xxxx	nnnn	dddd				
nmd type <div style="border: 1px solid black; padding: 2px; margin-top: 5px;"> <span style="float: left;">15</span> <span style="float: right;">0</span> <table style="width: 100%; border-collapse: collapse;"> <tr> <td style="border: 1px solid black; width: 25%;">xxxx</td> <td style="border: 1px solid black; width: 25%;">nnnn</td> <td style="border: 1px solid black; width: 25%;">mmmm</td> <td style="border: 1px solid black; width: 25%;">dddd</td> </tr> </table> </div>	xxxx	nnnn	mmmm	dddd	mmmmn: register direct	nnnndddd: register indirect with displacement	MOV.L Rm,@(disp,Rn)
xxxx	nnnn	mmmm	dddd				
	mmmmdddd: register indirect with displacement	nnnn: register direct	MOV.L @(disp,Rm),Rn				

Instruction Format	Source Operand	Destination Operand	Sample Instruction
<b>d type</b> 	dddddddd: GBR indirect with displacement	R0 (register direct)	MOV.L @(disp,GBR),R0
	R0 (register direct)	dddddddd: GBR indirect with displacement	MOV.L R0,@(disp,GBR)
	dddddddd: PC relative with displacement	R0 (register direct)	MOVA @(disp,PC),R0
	—	dddddddd: PC relative	BF label
<b>d12 type</b> 	—	dddddddddddd: PC relative	BRA label (label=disp+PC)
<b>nd8 type</b> 	dddddddd: PC relative with displacement	nnnn: register direct	MOV.L @(disp,PC),Rn
<b>i type</b> 	iiiiiiii: immediate	Index GBR indirect	AND.B #imm,@(R0,GBR)
	iiiiiiii: immediate	R0 (register direct)	AND #imm,R0
	iiiiiiii: immediate	—	TRAPA #imm
<b>ni type</b> 	iiiiiiii: immediate	nnnn: register direct	ADD #imm,Rn

Note: \* In multiply and accumulate instructions, nnnn is the source register.

## 2.5 Instruction Set

### 2.5.1 Instruction Set by Type

Table 2.10 lists the instructions classified by type.

**Table 2.10 Instruction Types**

Type	Kinds of Instruction	Op Code	Function	Number of Instructions
Data transfer instructions	5	MOV	Data transfer Immediate data transfer Peripheral module data transfer Structure data transfer	39
		MOVA	Effective address transfer	
		MOVT	T bit transfer	
		SWAP	Upper/lower swap	
		XTRCT	Extraction of middle of linked registers	
		Arithmetic operation instructions	21	
		ADDC	Binary addition with carry	
		ADDV	Binary addition with overflow	
		CMP/cond	Comparison	
		DIV1	Division	
		DIV0S	Signed division initialization	
		DIV0U	Unsigned division initialization	
		DMULS	Signed double-precision multiplication	
		DMULU	Unsigned double-precision multiplication	
		DT	Decrement and test	
		EXTS	Sign extension	
		EXTU	Zero extension	
		MAC	Multiply-and-accumulate, double-precision multiply-and-accumulate	
		MUL	Double-precision multiplication	

Type	Kinds of Instruction	Op Code	Function	Number of Instructions
Arithmetic operation instructions	21	MULS	Signed multiplication	33
		MULU	Unsigned multiplication	
		NEG	Sign inversion	
		NEGC	Sign inversion with borrow	
		SUB	Binary subtraction	
		SUBC	Binary subtraction with carry	
		SUBV	Binary subtraction with underflow	
Logic operation instructions	6	AND	Logical AND	14
		NOT	Bit inversion	
		OR	Logical OR	
		TAS	Memory test and bit setting	
		TST	T bit setting for logical AND	
		XOR	Exclusive logical OR	
Shift instructions	10	ROTL	1-bit left shift	14
		ROTR	1-bit right shift	
		ROTCL	1-bit left shift with T bit	
		ROTCR	1-bit right shift with T bit	
		SHAL	Arithmetic 1-bit left shift	
		SHAR	Arithmetic 1-bit right shift	
		SHLL	Logical 1-bit left shift	
		SHLLn	Logical n-bit left shift	
		SHLR	Logical 1-bit right shift	
SHLRn	Logical n-bit right shift			

Type	Kinds of Instruction	Op Code	Function	Number of Instructions
Branch instructions	9	BF	Conditional branch, delayed conditional branch (T = 0)	11
		BT	Conditional branch, delayed conditional branch (T = 1)	
		BRA	Unconditional branch	
		BRAF	Unconditional branch	
		BSR	Branch to subroutine procedure	
		BSRF	Branch to subroutine procedure	
		JMP	Unconditional branch	
		JSR	Branch to subroutine procedure	
		RTS	Return from subroutine procedure	
System control instructions	11	CLRT	T bit clear	31
		CLRMAC	MAC register clear	
		LDC	Load into control register	
		LDS	Load into system register	
		NOP	No operation	
		RTE	Return from exception handling	
		SETT	T bit setting	
		SLEEP	Transition to power-down mode	
		STC	Store from control register	
		STS	Store from system register	
	TRAPA	Trap exception handling		
Total:	62			142

The instruction code, operation, and execution cycles of the instructions are listed in the following tables, classified by type.

Instruction	Instruction Code	Summary of Operation	Execution Cycles	T Bit
Indicated by mnemonic.	Indicated in MSB ↔ LSB order.	Indicates summary of operation.	Value when no wait cycles are inserted* <sup>1</sup>	Value of T bit after instruction is executed  Explanation of Symbols  —: No change
Explanation of Symbols	Explanation of Symbols	Explanation of Symbols		
OP.Sz SRC, DEST	mmmm: Source register	→, ←: Transfer direction		
OP: Operation code	nnnn: Destination register	(xx): Memory operand		
Sz: Size	0000: R0	M/Q/T: Flag bits in SR		
SRC: Source	0001: R1	&: Logical AND of each bit		
DEST: Destination	.....	: Logical OR of each bit		
Rm: Source register	1111: R15	^: Exclusive logical OR of each bit		
Rn: Destination register	iiii: Immediate data	—: Logical NOT of each bit		
imm: Immediate data	dddd: Displacement	<<n: n-bit left shift		
disp: Displacement* <sup>2</sup>		>>n: n-bit right shift		

- Notes: 1. The table shows the minimum number of execution states. In practice, the number of instruction execution states will be increased in cases such as the following:
- When there is contention between an instruction fetch and a data access
  - When the destination register of a load instruction (memory → register) is also used by the following instruction
2. Scaled (×1, ×2, or ×4) according to the instruction operand size, etc.  
For details, see SH-1/SH-2/SH-DSP Software Manual.



## 2.5.2 Data Transfer Instructions

**Table 2.11 Data Transfer Instructions**

Instruction	Operation	Code	Execution Cycles	T Bit
MOV #imm, Rn	imm → Sign extension → Rn	1110nnnniiiiiii	1	—
MOV.W @(disp, PC), Rn	(disp × 2 + PC) → Sign extension → Rn	1001nnnnddddddd	1	—
MOV.L @(disp, PC), Rn	(disp × 4 + PC) → Rn	1101nnnnddddddd	1	—
MOV Rm, Rn	Rm → Rn	0110nnnnmmmm0011	1	—
MOV.B Rm, @Rn	Rm → (Rn)	0010nnnnmmmm0000	1	—
MOV.W Rm, @Rn	Rm → (Rn)	0010nnnnmmmm0001	1	—
MOV.L Rm, @Rn	Rm → (Rn)	0010nnnnmmmm0010	1	—
MOV.B @Rm, Rn	(Rm) → Sign extension → Rn	0110nnnnmmmm0000	1	—
MOV.W @Rm, Rn	(Rm) → Sign extension → Rn	0110nnnnmmmm0001	1	—
MOV.L @Rm, Rn	(Rm) → Rn	0110nnnnmmmm0010	1	—
MOV.B Rn, @-Rn	Rn-1 → Rn, Rm → (Rn)	0010nnnnmmmm0100	1	—
MOV.W Rn, @-Rn	Rn-2 → Rn, Rm → (Rn)	0010nnnnmmmm0101	1	—
MOV.L Rn, @-Rn	Rn-4 → Rn, Rm → (Rn)	0010nnnnmmmm0110	1	—
MOV.B @Rm+, Rn	(Rm) → Sign extension → Rn, Rm + 1 → Rm	0110nnnnmmmm0100	1	—
MOV.W @Rm+, Rn	(Rm) → Sign extension → Rn, Rm + 2 → Rm	0110nnnnmmmm0101	1	—
MOV.L @Rm+, Rn	(Rm) → Rn, Rm + 4 → Rm	0110nnnnmmmm0110	1	—
MOV.B R0, @(disp, Rn)	R0 → (disp + Rn)	10000000nnnndddd	1	—
MOV.W R0, @(disp, Rn)	R0 → (disp × 2 + Rn)	10000001nnnndddd	1	—
MOV.L Rm, @(disp, Rn)	Rm → (disp × 4 + Rn)	0001nnnnmmmmdddd	1	—
MOV.B @(disp, Rm), R0	(disp + Rm) → Sign extension → R0	10000100mmmmdddd	1	—
MOV.W @(disp, Rm), R0	(disp × 2 + Rm) → Sign extension → R0	10000101mmmmdddd	1	—
MOV.L @(disp, Rm), Rn	(disp × 4 + Rm) → Rn	0101nnnnmmmmdddd	1	—

Instruction	Operation	Code	Execution Cycles	T Bit
MOV.B Rm, @(R0, Rn)	Rm → (R0 + Rn)	0000nnnnnnmmmm0100	1	—
MOV.W Rm, @(R0, Rn)	Rm → (R0 + Rn)	0000nnnnnnmmmm0101	1	—
MOV.L Rm, @(R0, Rn)	Rm → (R0 + Rn)	0000nnnnnnmmmm0110	1	—
MOV.B @(R0, Rm), Rn	(R0 + Rm) → Sign extension → Rn	0000nnnnnnmmmm1100	1	—
MOV.W @(R0, Rm), Rn	(R0 + Rm) → Sign extension → Rn	0000nnnnnnmmmm1101	1	—
MOV.L @(R0, Rm), Rn	(R0 + Rm) → Rn	0000nnnnnnmmmm1110	1	—
MOV.B R0, @(disp, GBR)	R0 → (disp + GBR)	11000000dddddddd	1	—
MOV.W R0, @(disp, GBR)	R0 → (disp × 2 + GBR)	11000001dddddddd	1	—
MOV.L R0, @(disp, GBR)	R0 → (disp × 4 + GBR)	11000010dddddddd	1	—
MOV.B @(disp, GBR), R0	(disp + GBR) → Sign extension → R0	11000100dddddddd	1	—
MOV.W @(disp, GBR), R0	(disp × 2 + GBR) → Sign extension → R0	11000101dddddddd	1	—
MOV.L @(disp, GBR), R0	(disp × 4 + GBR) → R0	11000110dddddddd	1	—
MOVA @(disp, PC), R0	disp × 4 + PC → R0	11000111dddddddd	1	—
MOVT Rn	T → Rn	0000nnnn00101001	1	—
SWAP.B Rm, Rn	Rm → Swap lowest two bytes → Rn	0110nnnnnnmmmm1000	1	—
SWAP.W Rm, Rn	Rm → Swap two consecutive words → Rn	0110nnnnnnmmmm1001	1	—
XTRCT Rm, Rn	Rm: Middle 32 bits of Rn → Rn	0010nnnnnnmmmm1101	1	—

## 2.5.3 Arithmetic Operation Instructions

**Table 2.12 Arithmetic Operation Instructions**

Instruction		Operation	Code	Execution Cycles	T Bit
ADD	Rm, Rn	$Rn + Rm \rightarrow Rn$	0011nnnnnnmm1100	1	—
ADD	#imm, Rn	$Rn + imm \rightarrow Rn$	0111nnnniiiiiii	1	—
ADDC	Rm, Rn	$Rn + Rm + T \rightarrow Rn$ , Carry $\rightarrow T$	0011nnnnnnmm1110	1	Carry
ADDV	Rm, Rn	$Rn + Rm \rightarrow Rn$ , Overflow $\rightarrow T$	0011nnnnnnmm1111	1	Overflow
CMP/EQ	#imm, R0	If $R0 = imm$ , $1 \rightarrow T$	10001000iiiiiii	1	Comparison result
CMP/EQ	Rm, Rn	If $Rn = Rm$ , $1 \rightarrow T$	0011nnnnnnmm0000	1	Comparison result
CMP/HS	Rm, Rn	If $Rn \geq Rm$ with unsigned data, $1 \rightarrow T$	0011nnnnnnmm0010	1	Comparison result
CMP/GE	Rm, Rn	If $Rn \geq Rm$ with signed data, $1 \rightarrow T$	0011nnnnnnmm0011	1	Comparison result
CMP/HI	Rm, Rn	If $Rn > Rm$ with unsigned data, $1 \rightarrow T$	0011nnnnnnmm0110	1	Comparison result
CMP/GT	Rm, Rn	If $Rn > Rm$ with signed data, $1 \rightarrow T$	0011nnnnnnmm0111	1	Comparison result
CMP/PZ	Rn	If $Rn \geq 0$ , $1 \rightarrow T$	0100nnnn00010001	1	Comparison result
CMP/PL	Rn	If $Rn > 0$ , $1 \rightarrow T$	0100nnnn00010101	1	Comparison result
CMP/STR	Rm, Rn	If Rn and Rm have an equivalent byte, $1 \rightarrow T$	0010nnnnnnmm1100	1	Comparison result
DIV1	Rm, Rn	Single-step division (Rn/Rm)	0011nnnnnnmm0100	1	Calculation result
DIV0S	Rm, Rn	MSB of Rn $\rightarrow Q$ , MSB of Rm $\rightarrow M$ , $M \wedge Q \rightarrow T$	0010nnnnnnmm0111	1	Calculation result
DIV0U		$0 \rightarrow M/Q/T$	000000000011001	1	0
DMULS.L	Rm, Rn	Signed operation of $Rn \times Rm \rightarrow MACH$ , $MACL 32 \times 32 \rightarrow 64$ bits	0011nnnnnnmm1101	2 to 5*	—

Instruction	Operation	Code	Execution Cycles	T Bit
DMULU.L Rm, Rn	Unsigned operation of $Rn \times Rm \rightarrow MACH$ , $MACL 32 \times 32 \rightarrow 64$ bits	0011nnnnnnmmmm0101	2 to 5*	—
DT Rn	$Rn - 1 \rightarrow Rn$ , if $Rn = 0$ , $1 \rightarrow T$ , else $0 \rightarrow T$	0100nnnn00010000	1	Comparison result
EXTS.B Rm, Rn	A byte in Rm is sign-extended $\rightarrow Rn$	0110nnnnnnmmmm1110	1	—
EXTS.W Rm, Rn	A word in Rm is sign-extended $\rightarrow Rn$	0110nnnnnnmmmm1111	1	—
EXTU.B Rm, Rn	A byte in Rm is zero-extended $\rightarrow Rn$	0110nnnnnnmmmm1100	1	—
EXTU.W Rm, Rn	A word in Rm is zero-extended $\rightarrow Rn$	0110nnnnnnmmmm1101	1	—
MAC.L @Rm+, @Rn+	Signed operation of (Rn) $\times$ (Rm) + MAC $\rightarrow$ MAC, $32 \times 32 + 64 \rightarrow 64$ bits	0000nnnnnnmmmm1111	2 to 5*	—
MAC.W @Rm+, @Rn+	Signed operation of (Rn) $\times$ (Rm) + MAC $\rightarrow$ MAC, $16 \times 16 + 64 \rightarrow 64$ bits	0100nnnnnnmmmm1111	2 to 4*	—
MUL.L Rm, Rn	$Rn \times Rm \rightarrow MACL$ $32 \times 32 \rightarrow 32$ bits	0000nnnnnnmmmm0111	2 to 5*	—
MULS.W Rm, Rn	Signed operation of $Rn \times Rm \rightarrow MAC$ $16 \times 16 \rightarrow 32$ bits	0010nnnnnnmmmm1111	1 to 3*	—
MULU.W Rm, Rn	Unsigned operation of $Rn \times Rm \rightarrow MAC$ $16 \times 16 \rightarrow 32$ bits	0010nnnnnnmmmm1110	1 to 3*	—
NEG Rm, Rn	$0-Rm \rightarrow Rn$	0110nnnnnnmmmm1011	1	—
NEGC Rm, Rn	$0-Rm-T \rightarrow Rn$ , Borrow $\rightarrow T$	0110nnnnnnmmmm1010	1	Borrow
SUB Rm, Rn	$Rn-Rm \rightarrow Rn$	0011nnnnnnmmmm1000	1	—
SUBC Rm, Rn	$Rn-Rm-T \rightarrow Rn$ , Borrow $\rightarrow T$	0011nnnnnnmmmm1010	1	Borrow
SUBV Rm, Rn	$Rn-Rm \rightarrow Rn$ , Underflow $\rightarrow T$	0011nnnnnnmmmm1011	1	Underflow

Note: \* Indicates the number of execution cycles for normal operation.

## 2.5.4 Logic Operation Instructions

**Table 2.13 Logic Operation Instructions**

Instruction	Operation	Code	Execution Cycles	T Bit
AND Rm, Rn	$Rn \& Rm \rightarrow Rn$	0010nnnnmmmm1001	1	—
AND #imm, R0	$R0 \& imm \rightarrow R0$	11001001iiiiiiii	1	—
AND.B #imm, @(R0, GBR)	$(R0 + GBR) \& imm \rightarrow (R0 + GBR)$	11001101iiiiiiii	3	—
NOT Rm, Rn	$\sim Rm \rightarrow Rn$	0110nnnnmmmm0111	1	—
OR Rm, Rn	$Rn   Rm \rightarrow Rn$	0010nnnnmmmm1011	1	—
OR #imm, R0	$R0   imm \rightarrow R0$	11001011iiiiiiii	1	—
OR.B #imm, @(R0, GBR)	$(R0 + GBR)   imm \rightarrow (R0 + GBR)$	11001111iiiiiiii	3	—
TAS.B @Rn	If (Rn) is 0, 1 $\rightarrow$ T; 1 $\rightarrow$ MSB of (Rn)	0100nnnn00011011	4	Test result
TST Rm, Rn	$Rn \& Rm$ ; if the result is 0, 1 $\rightarrow$ T	0010nnnnmmmm1000	1	Test result
TST #imm, R0	$R0 \& imm$ ; if the result is 0, 1 $\rightarrow$ T	11001000iiiiiiii	1	Test result
TST.B #imm, @(R0, GBR)	$(R0 + GBR) \& imm$ ; if the result is 0, 1 $\rightarrow$ T	11001100iiiiiiii	3	Test result
XOR Rm, Rn	$Rn \wedge Rm \rightarrow Rn$	0010nnnnmmmm1010	1	—
XOR #imm, R0	$R0 \wedge imm \rightarrow R0$	11001010iiiiiiii	1	—
XOR.B #imm, @(R0, GBR)	$(R0 + GBR) \wedge imm \rightarrow (R0 + GBR)$	11001110iiiiiiii	3	—

## 2.5.5 Shift Instructions

**Table 2.14 Shift Instructions**

Instruction	Operation	Code	Execution Cycles	T Bit
ROTL Rn	$T \leftarrow Rn \leftarrow MSB$	0100nnnn00000100	1	MSB
ROTR Rn	$LSB \rightarrow Rn \rightarrow T$	0100nnnn00000101	1	LSB
ROTCL Rn	$T \leftarrow Rn \leftarrow T$	0100nnnn00100100	1	MSB
ROTCR Rn	$T \rightarrow Rn \rightarrow T$	0100nnnn00100101	1	LSB
SHAL Rn	$T \leftarrow Rn \leftarrow 0$	0100nnnn00100000	1	MSB
SHAR Rn	$MSB \rightarrow Rn \rightarrow T$	0100nnnn00100001	1	LSB
SHLL Rn	$T \leftarrow Rn \leftarrow 0$	0100nnnn00000000	1	MSB
SHLR Rn	$0 \rightarrow Rn \rightarrow T$	0100nnnn00000001	1	LSB
SHLL2 Rn	$Rn \ll 2 \rightarrow Rn$	0100nnnn00001000	1	—
SHLR2 Rn	$Rn \gg 2 \rightarrow Rn$	0100nnnn00001001	1	—
SHLL8 Rn	$Rn \ll 8 \rightarrow Rn$	0100nnnn00011000	1	—
SHLR8 Rn	$Rn \gg 8 \rightarrow Rn$	0100nnnn00011001	1	—
SHLL16 Rn	$Rn \ll 16 \rightarrow Rn$	0100nnnn00101000	1	—
SHLR16 Rn	$Rn \gg 16 \rightarrow Rn$	0100nnnn00101001	1	—

## 2.5.6 Branch Instructions

**Table 2.15 Branch Instructions**

Instruction		Operation	Code	Execution Cycles	T Bit
BF	label	If T = 0, disp × 2 + PC → PC; if T = 1, nop	10001011dddddddd	3/1*	—
BF/S	label	Delayed branch, if T = 0, disp × 2 + PC → PC; if T = 1, nop	10001111dddddddd	2/1*	—
BT	label	If T = 1, disp × 2 + PC → PC; if T = 0, nop	10001001dddddddd	3/1*	—
BT/S	label	Delayed branch, if T = 1, disp × 2 + PC → PC; if T = 0, nop	10001101dddddddd	2/1*	—
BRA	label	Delayed branch, disp × 2 + PC → PC	1010dddddddddddd	2	—
BRAF	Rm	Delayed branch, Rm + PC → PC	0000mmmm00100011	2	—
BSR	label	Delayed branch, PC → PR, disp × 2 + PC → PC	1011dddddddddddd	2	—
BSRF	Rm	Delayed branch, PC → PR, Rm + PC → PC	0000mmmm00000011	2	—
JMP	@Rm	Delayed branch, Rm → PC	0100mmmm00101011	2	—
JSR	@Rm	Delayed branch, PC → PR, Rm → PC	0100mmmm00001011	2	—
RTS		Delayed branch, PR → PC	0000000000001011	2	—

Note: \* One cycle when the branch is not executed.

## 2.5.7 System Control Instructions

**Table 2.16 System Control Instructions**

Instruction	Operation	Code	Execution Cycles	T Bit
CLRT	0 → T	0000000000001000	1	0
CLRMAC	0 → MACH, MACL	000000000101000	1	—
LDC Rm, SR	Rm → SR	0100mmmm00001110	1	LSB
LDC Rm, GBR	Rm → GBR	0100mmmm00011110	1	—
LDC Rm, VBR	Rm → VBR	0100mmmm00101110	1	—
LDC.L @Rm+, SR	(Rm) → SR, Rm + 4 → Rm	0100mmmm00000111	3	LSB
LDC.L @Rm+, GBR	(Rm) → GBR, Rm + 4 → Rm	0100mmmm00010111	3	—
LDC.L @Rm+, VBR	(Rm) → VBR, Rm + 4 → Rm	0100mmmm00100111	3	—
LDS Rm, MACH	Rm → MACH	0100mmmm00001010	1	—
LDS Rm, MACL	Rm → MACL	0100mmmm00011010	1	—
LDS Rm, PR	Rm → PR	0100mmmm00101010	1	—
LDS.L @Rm+, MACH	(Rm) → MACH, Rm + 4 → Rm	0100mmmm00000110	1	—
LDS.L @Rm+, MACL	(Rm) → MACL, Rm + 4 → Rm	0100mmmm00010110	1	—
LDS.L @Rm+, PR	(Rm) → PR, Rm + 4 → Rm	0100mmmm00100110	1	—
NOP	No operation	000000000001001	1	—
RTE	Delayed branch, Stack area → PC/SR	000000000101011	5	—
SETT	1 → T	000000000011000	1	1
SLEEP	Sleep	000000000011011	4*	—
STC SR, Rn	SR → Rn	0000nnnn00000010	1	—
STC GBR, Rn	GBR → Rn	0000nnnn00010010	1	—
STC VBR, Rn	VBR → Rn	0000nnnn00100010	1	—
STC.L SR, @-Rn	Rn-4 → Rn, SR → (Rn)	0100nnnn00000011	1	—
STC.L GBR, @-Rn	Rn-4 → Rn, GBR → (Rn)	0100nnnn00010011	1	—
STC.L VBR, @-Rn	Rn-4 → Rn, VBR → (Rn)	0100nnnn00100011	1	—



Instruction	Operation	Code	Execution Cycles	T Bit
STS MACH, Rn	MACH → Rn	0000nnnn00001010	1	—
STS MACL, Rn	MACL → Rn	0000nnnn00011010	1	—
STS PR, Rn	PR → Rn	0000nnnn00101010	1	—
STS.L MACH, @-Rn	Rn-4 → Rn, MACH → (Rn)	0100nnnn00000010	1	—
STS.L MACL, @-Rn	Rn-4 → Rn, MACL → (Rn)	0100nnnn00010010	1	—
STS.L PR, @-Rn	Rn-4 → Rn, PR → (Rn)	0100nnnn00100010	1	—
TRAPA #imm	PC/SR → Stack area, (imm × 4 + VBR) → PC	11000011iiiiiiii	8	—

Note: \* Number of execution cycles until this LSI enters sleep mode.

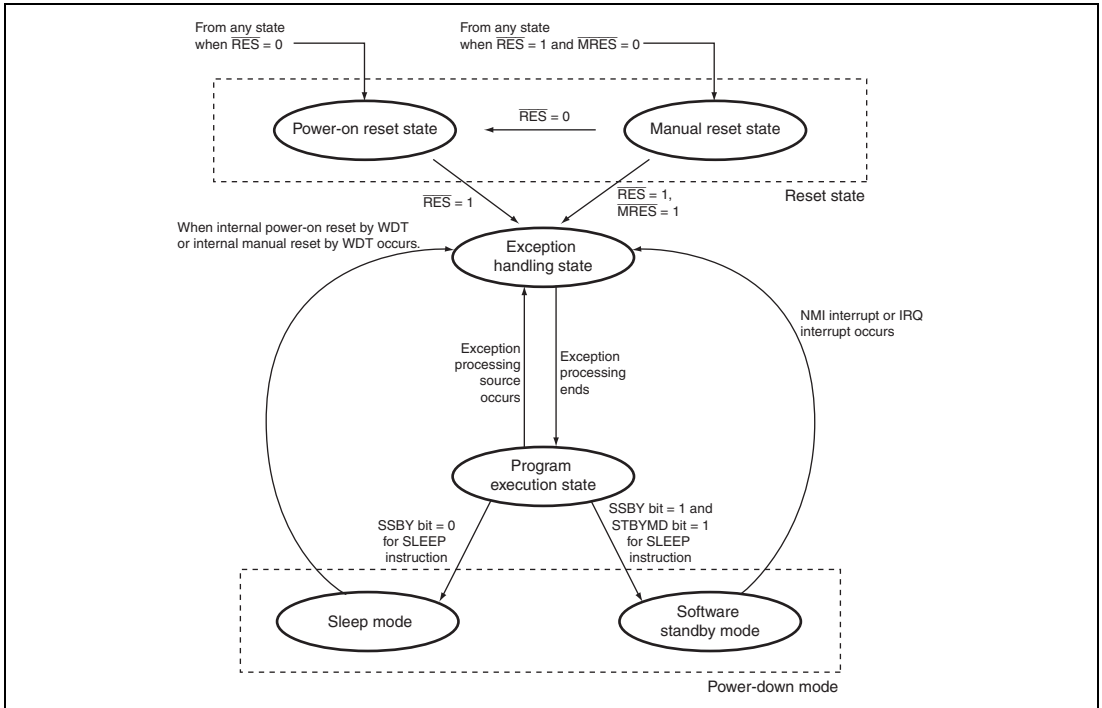
About the number of execution cycles:

The table lists the minimum number of execution cycles. In practice, the number of execution cycles will be increased depending on the conditions such as:

- When there is a conflict between instruction fetch and data access
- When the destination register of a load instruction (memory → register) is also used by the instruction immediately after the load instruction.

## 2.6 Processing States

The CPU has the five processing states: reset, exception handling, program execution, and power-down. Figure 2.4 shows the CPU state transition.



**Figure 2.4 Transitions between Processing States**

- Reset state

The CPU is reset. When the  $\overline{\text{RES}}$  pin is low, the CPU enters the power-on reset state. When the  $\overline{\text{RES}}$  pin is high and  $\overline{\text{MRES}}$  pin is low, the CPU enters the manual reset state.

- Exception handling state

This state is a transitional state in which the CPU processing state changes due to a request for exception handling such as a reset or an interrupt.

When a reset occurs, the execution start address as the initial value of the program counter (PC) and the initial value of the stack pointer (SP) are fetched from the exception handling vector table. Then, a branch is made for the start address to execute a program.

When an interrupt occurs, the PC and status register (SR) are saved in the stack area pointed to by SP. The start address of an exception handling routine is fetched from the exception handling vector table and a branch to the address is made to execute a program.

Then the processing state enters the program execution state.

- Program execution state

The CPU executes programs sequentially.

- Power-down state

The CPU stops to reduce power consumption. The SLEEP instruction makes the CPU enter sleep mode or software standby mode.



## Section 3 MCU Operating Modes

### 3.1 Selection of Operating Modes

This LSI has four MCU operating modes and three on-chip flash memory programming modes. The operating mode is determined by the setting of FWE, MD1, and MD0 pins. Table 3.1 shows the allowable combinations of these pin settings; do not set these pins in the other way than the shown combinations.

When power is applied to the system, be sure to conduct power-on reset.

The MCU operating mode can be selected from MCU extension modes 0 to 2 and single chip mode. For the on-chip flash memory programming mode, boot mode, user boot mode, and user program mode, which are on-chip programming modes are available.

**Table 3.1 Selection of Operating Modes**

Mode No.	Pin Setting		Mode Name	On-Chip ROM
	FWE	MD1		
Mode 3	0	1	Single chip mode	Active
Mode 4* <sup>1</sup>	1	0	Boot mode	Active
Mode 6* <sup>2</sup>	1	1	User program mode	Active

Notes: 1. Flash memory programming mode.  
2. Prohibited in SH71241.

## 3.2 Input/Output Pins

Table 3.2 describes the configuration of operating mode related pin.

**Table 3.2 Pin Configuration**

<b>Pin Name</b>	<b>Input/Output</b>	<b>Function</b>
MD1	Input	Designates operating mode through the level applied to this pin
FWE	Input	Enables, by hardware, programming/erasing of the on-chip flash memory

---

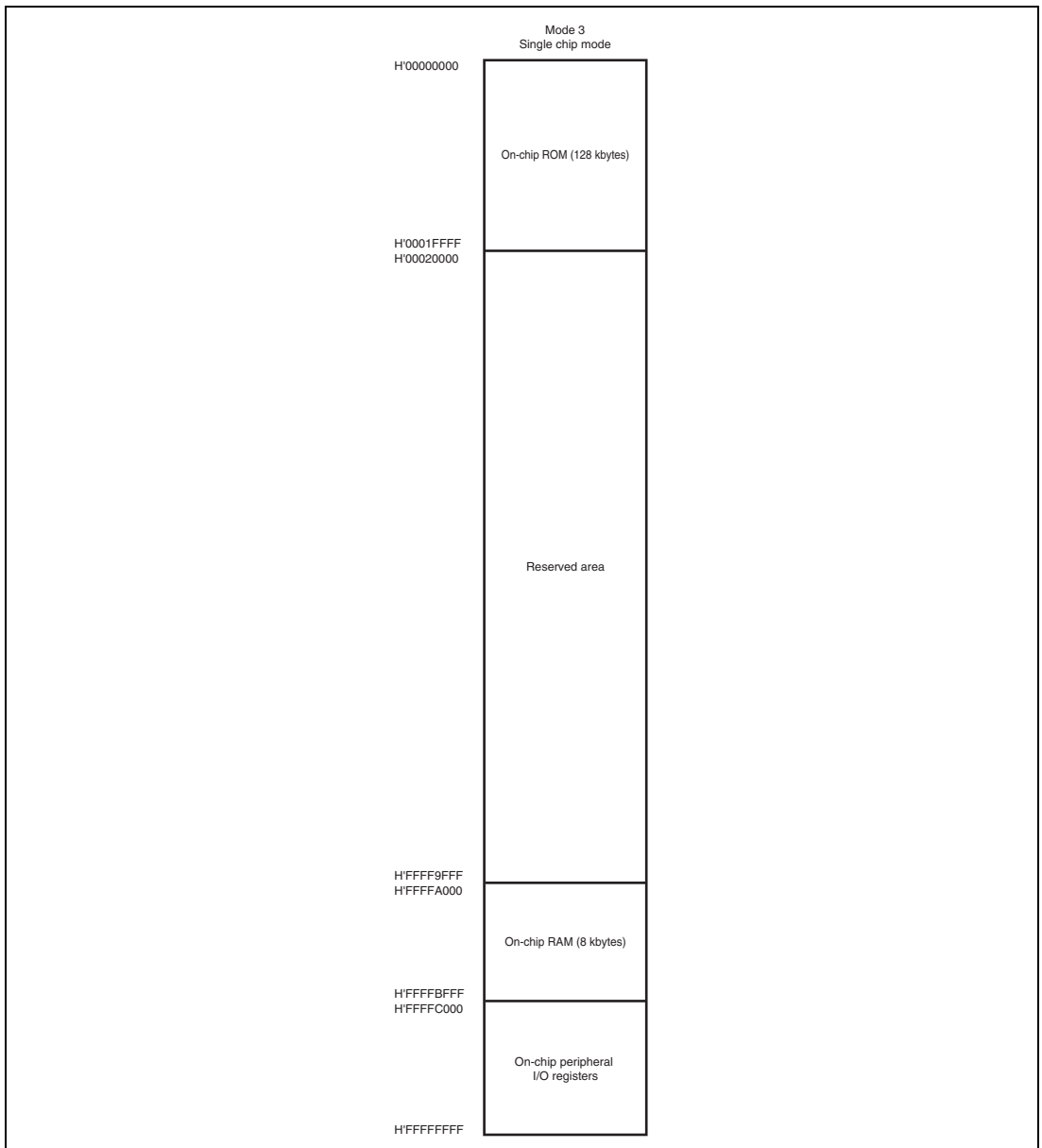
## 3.3 Operating Modes

### 3.3.1 Mode 3 (Single Chip Mode)

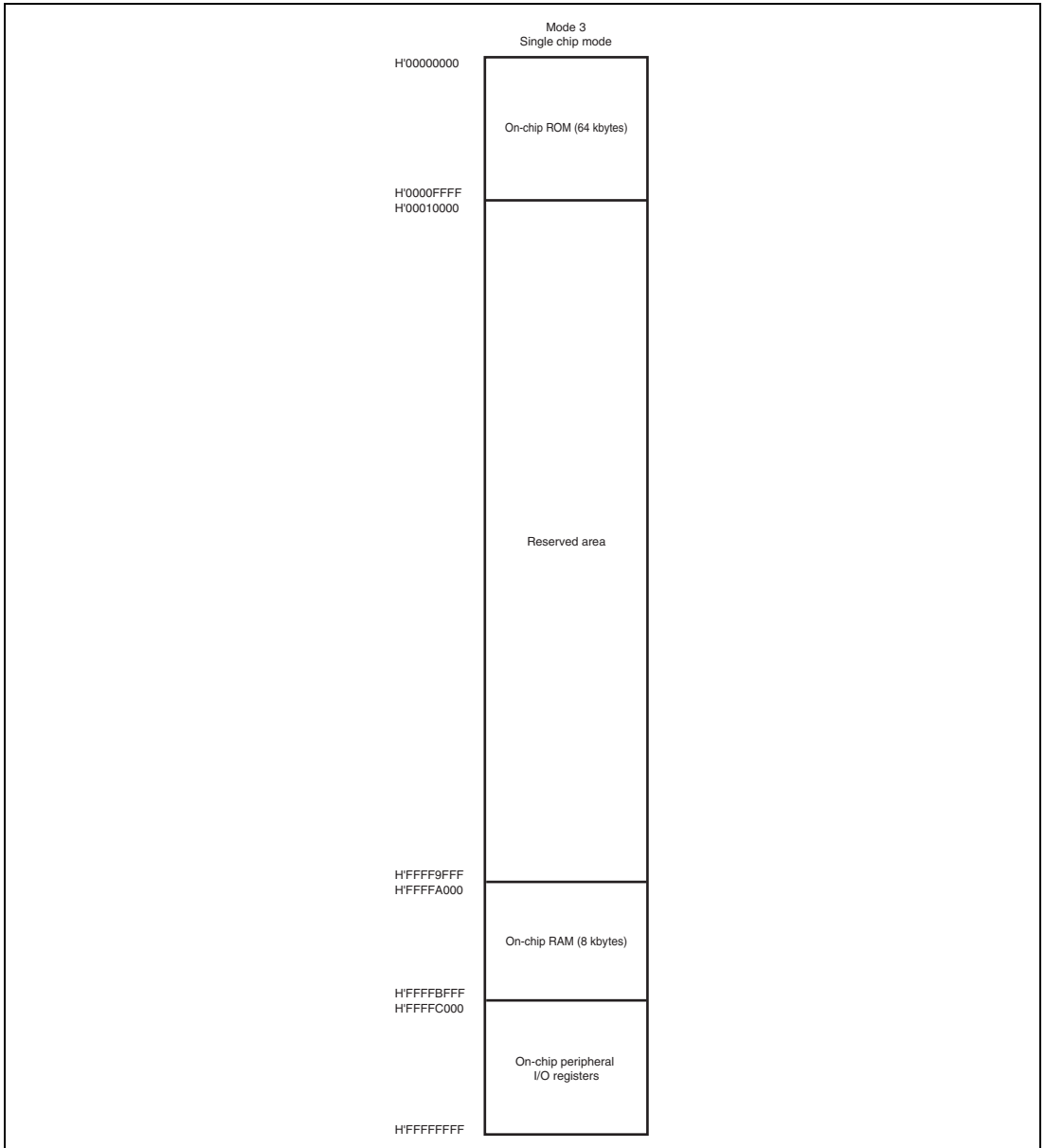
All ports can be used in this mode, however the external address cannot be used.

### 3.4 Address Map

The address map for the operating modes are shown in figures 3.1 to 3.3.

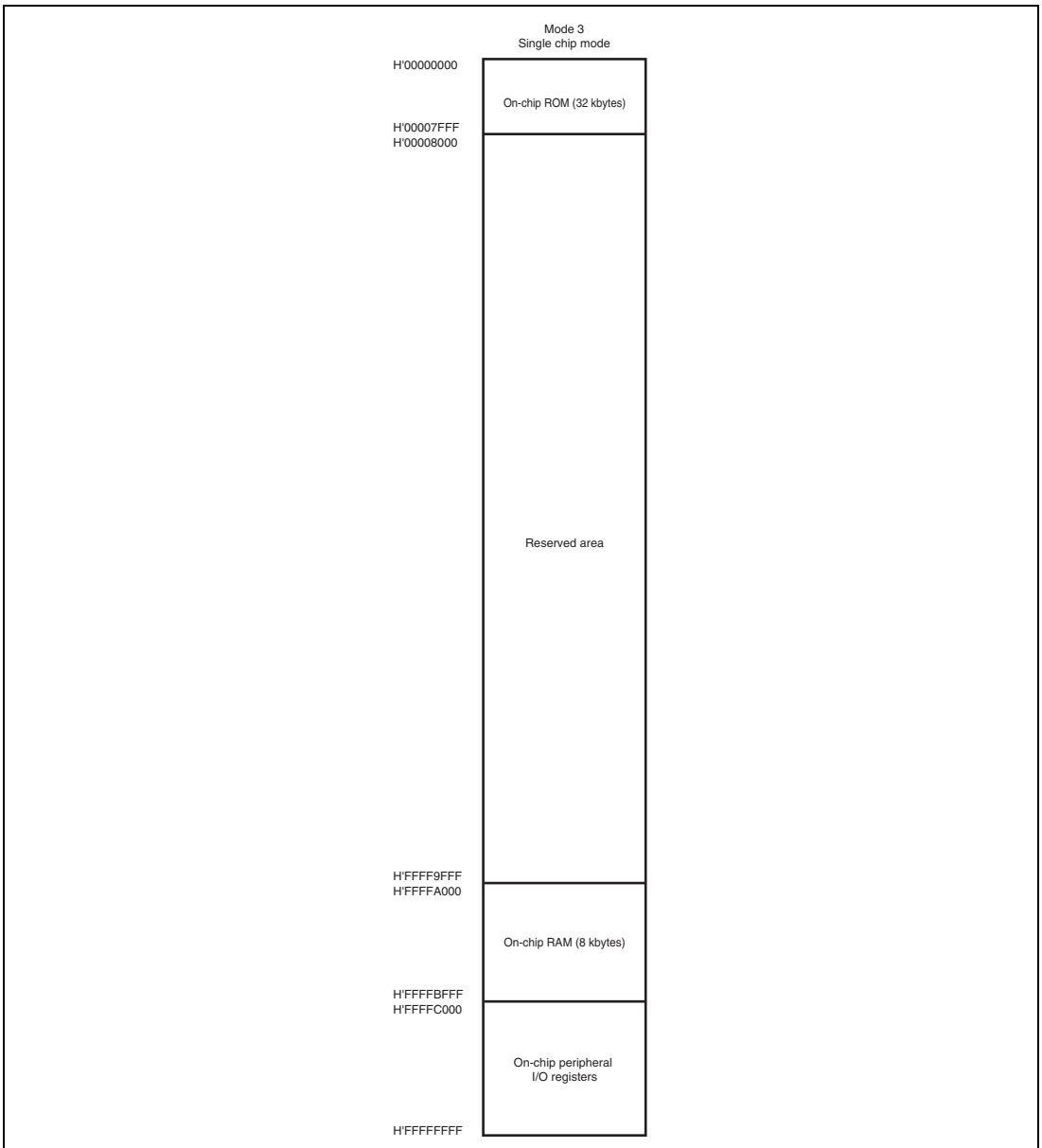


**Figure 3.1 Address Map in SH7125, SH7124 (128 Kbytes Flash Memory Version)**



**Figure 3.2 Address Map in SH7125, SH7124 (64 Kbytes Flash Memory Version)**





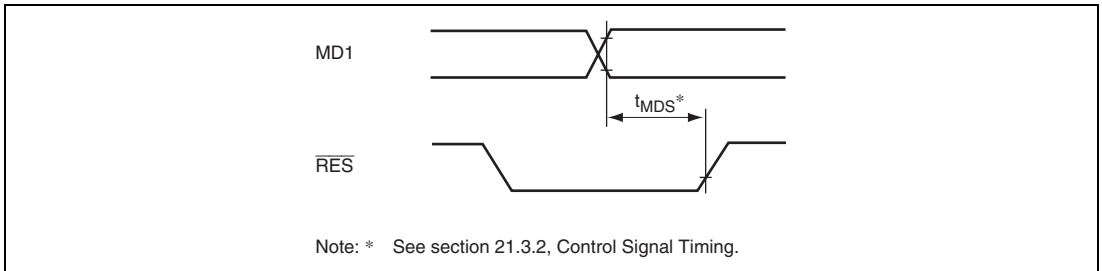
**Figure 3.3 Address Map in SH7124 (32 Kbytes Flash Memory Version)**

### 3.5 Initial State in This LSI

In the initial state of this LSI, some of on-chip modules are set in module standby state for saving power. When operating these modules, clear module standby state according to the procedure in section 19, Power-Down Modes.

### 3.6 Note on Changing Operating Mode

When changing operating mode while power is applied to this LSI, make sure to do it in the power-on reset state (that is, the low level is applied to the  $\overline{\text{RES}}$  pin).



**Figure 3.4 Reset Input Timing when Changing Operating Mode**

## Section 4 Clock Pulse Generator (CPG)

This LSI has a clock pulse generator (CPG) that generates an internal clock ( $I\phi$ ), a bus clock ( $B\phi$ ), a peripheral clock ( $P\phi$ ), and a clock ( $MP\phi$ ) for the MTU2 module. The CPG also controls power-down modes.

### 4.1 Features

- Five clocks generated independently

An internal clock ( $I\phi$ ) for the CPU; a peripheral clock ( $P\phi$ ) for the on-chip peripheral modules; a bus clock ( $B\phi = CK$ ) for the external bus interface; and a MTU2 clock ( $MP\phi$ ) for the on-chip MTU2 module.

- Frequency change function

Frequencies of the internal clock ( $I\phi$ ), bus clock ( $B\phi$ ), peripheral clock ( $P\phi$ ), and MTU2 clock ( $MP\phi$ ) can be changed independently using the divider circuit within the CPG. Frequencies are changed by software using the frequency control register (FRQCR) setting.

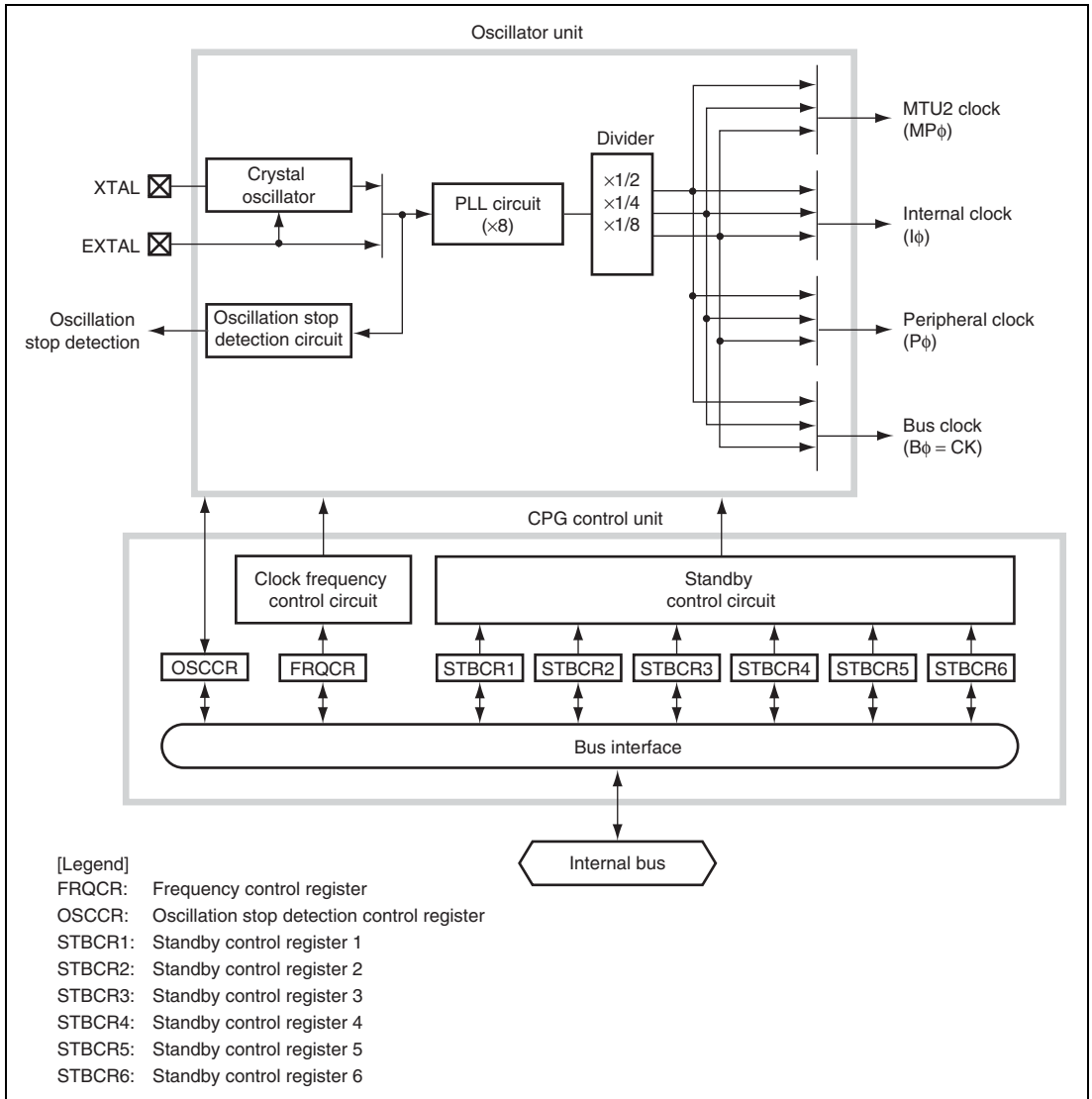
- Power-down mode control

The clock can be stopped in sleep mode and standby mode and specific modules can be stopped using the module standby function.

- Oscillation stop detection

If the clock supplied through the clock input pin stops for any reason, the timer pins can be automatically placed in the high-impedance state.

Figure 4.1 shows a block diagram of the CPG.



**Figure 4.1 Block Diagram of CPG**

The clock pulse generator blocks function as follows:

**PLL Circuit:** The PLL circuit multiplies the clock frequency input from the crystal oscillator or the EXTAL pin by 8. The multiplication ratio is fixed at  $\times 8$ .

**Crystal Oscillator:** The crystal oscillator is an oscillator circuit when a crystal resonator is connected to the XTAL and EXTAL pins.

**Divider:** The divider generates clocks with the frequencies to be used by the internal clock ( $I\phi$ ), bus clock ( $B\phi$ ), peripheral clock ( $P\phi$ ), and MTU2 clock ( $MP\phi$ ).

The frequencies can be selected from 1/2, 1/4 (initial value), and 1/8 times the frequency output from the PLL circuit. The division ratio should be specified in the frequency control register (FRQCR).

**Oscillation Stop Detection Circuit:** This circuit detects an abnormal condition in the crystal oscillator.

**Clock Frequency Control Circuit:** The clock frequency control circuit controls the clock frequency according to the setting in the frequency control register (FRQCR).

**Standby Control Circuit:** The standby control circuit controls the state of the on-chip oscillator circuit and other modules in sleep or standby mode.

**Frequency Control Register (FRQCR):** The frequency control register (FRQCR) has control bits for the frequency division ratios of the internal clock ( $I\phi$ ), bus clock ( $B\phi$ ), peripheral clock ( $P\phi$ ), and MTU2 clock ( $MP\phi$ ).

**Oscillation Stop Detection Control Register (OSCCR):** The oscillation stop detection control register (OSCCR) has an oscillation stop detection flag and a bit for selecting flag status output through an external pin.

**Standby Control Registers 1 to 6 (STBCR1 to STBCR6):** The standby control register (STBCR) has bits for controlling the power-down modes. For details, see section 19, Power-Down Modes.

Table 4.1 shows the operating clock for each module.

**Table 4.1 Operating Clock for Each Module**

<b>Operating Clock</b>	<b>Operating Module</b>	<b>Operating Clock</b>	<b>Operating Module</b>
Internal clock ( $I\phi$ )	CPU	Peripheral clock ( $P\phi$ )	POE
	UBC		SCI
	ROM		A/D
	RAM		CMT
			WDT
Bus clock ( $B\phi$ )	—	MTU2 clock ( $MP\phi$ )	MTU2

## 4.2 Input/Output Pins

Table 4.2 shows the CPG pin configuration.

**Table 4.2 Pin Configuration**

<b>Pin Name</b>	<b>Abbr.</b>	<b>I/O</b>	<b>Description</b>
Crystal input/output pins (clock input pins)	XTAL	Output	Connects a crystal resonator.
	EXTAL	Input	Connects a crystal resonator or an external clock.

### 4.3 Clock Operating Mode

Table 4.3 shows the clock operating mode of this LSI.

**Table 4.3 Clock Operating Mode**

Source	PLL Circuit	Input to Divider
EXTAL input or crystal resonator	ON (×8)	×8

The frequency of the external clock input from the EXTAL pin is multiplied by 8 in the PLL circuit before being supplied to the on-chip modules in this LSI, which eliminates the need to generate a high-frequency clock outside the LSI. Since the input clock frequency ranging from 10 MHz to 12.5 MHz can be used, the internal clock ( $I\phi$ ) frequency ranges from 10 MHz to 50 MHz.

Maximum operating frequencies:

$I\phi = 50$  MHz,  $B\phi = 40$  MHz,  $P\phi = 40$  MHz, and  $MP\phi = 40$  MHz

Table 4.4 shows the frequency division ratios that can be specified with FRQCR.

**Table 4.4 Frequency Division Ratios Specifiable with FRQCR**

PLL Multipli- cation Ratio	FRQCR Division Ratio Setting				Clock Ratio				Clock Frequency (MHz)*				
	I $\phi$	B $\phi$	P $\phi$	MP $\phi$	I $\phi$	B $\phi$	P $\phi$	MP $\phi$	Input Clock				
									I $\phi$	B $\phi$	P $\phi$	MP $\phi$	
×8	1/8	1/8	1/8	1/8	1	1	1	1	10	10	10	10	10
	1/4	1/8	1/8	1/8	2	1	1	1	10	20	10	10	10
	1/4	1/4	1/4	1/4	2	2	2	2	10	20	20	20	20
	1/2	1/4	1/4	1/4	4	2	2	2	10	40	20	20	20
	1/2	1/2	1/2	1/2	4	4	4	4	10	40	40	40	40
	1/8	1/8	1/8	1/8	1	1	1	1	12.5	12.5	12.5	12.5	12.5
	1/4	1/8	1/8	1/8	2	1	1	1	12.5	25	12.5	12.5	12.5
	1/4	1/4	1/4	1/4	2	2	2	2	12.5	25	25	25	25
1/2	1/4	1/4	1/4	4	2	2	2	12.5	50	25	25	25	

Notes: \* Clock frequencies when the input clock frequency is assumed to be the shown value. The internal clock (I $\phi$ ) frequency must be 10 to 50 MHz and the peripheral clock (P $\phi$ ) frequency must be 10 to 40 MHz. The bus clock (B $\phi$ ) frequency must be equal to the peripheral clock (P $\phi$ ) frequency.

1. The PLL multiplication ratio is fixed at ×8. The division ratio can be selected from ×1/2, ×1/4, and ×1/8 for each clock by the setting in the frequency control register.
2. The output frequency of the PLL circuit is the product of the frequency of the input from the crystal resonator or EXTAL pin and the multiplication ratio (×8) of the PLL circuit.
3. The input to the divider is always the output from the PLL circuit.
4. The internal clock (I $\phi$ ) frequency is the product of the frequency of the input from the crystal resonator or EXTAL pin, the multiplication ratio (×8) of the PLL circuit, and the division ratio of the divider. The resultant frequency must be a maximum of 50 MHz (maximum operating frequency).
5. The peripheral clock (P $\phi$ ) frequency is the product of the frequency of the input from the crystal resonator or EXTAL pin, the multiplication ratio (×8) of the PLL circuit, and the division ratio of the divider. The resultant frequency must be a maximum of 40 MHz.
6. When using the MTU2, the MTU2 clock (MP $\phi$ ) frequency must be equal to or higher than the peripheral clock frequency (P $\phi$ ). The MTU2 clock (MP $\phi$ ) frequency are the product of the frequency of the input from the crystal resonator or EXTAL pin, the multiplication ratio (×8) of the PLL circuit, and the division ratio of the divider.
7. The frequency of the CK pin is always be equal to the bus clock (B $\phi$ ) frequency.
8. The bus clock (B $\phi$ ) frequency must be equal to the peripheral clock (P $\phi$ ) frequency.



## 4.4 Register Descriptions

The CPG has the following registers.

For details on the addresses of these registers and the states of these registers in each processing state, see section 20, List of Registers

**Table 4.5 Register Configuration**

Register Name	Abbreviation	R/W	Initial Value	Address	Access Size
Frequency control register	FRQCR	R/W	H'36DB	H'FFFE800	16
Oscillation stop detection control register	OSCCR	R/W	H'00	H'FFFE814	8

### 4.4.1 Frequency Control Register (FRQCR)

FRQCR is a 16-bit readable/writable register that specifies the frequency division ratios for the internal clock ( $I\phi$ ), bus clock ( $B\phi$ ), peripheral clock ( $P\phi$ ), and MTU2 clock ( $MP\phi$ ). FRQCR can be accessed only in words.

FRQCR is initialized to H'36DB only by a power-on reset (except a power-on reset due to a WDT overflow).

Before making changes to FRQCR, stop clock supply to each module except the CPU, on-chip ROM, and on-chip-RAM.

Bit:	15	14	13	12	11	10	9	8	7	6	5	4	3	2	1	0
	-	IFC[2:0]			BFC[2:0]			PFC[2:0]			-	-	-	MPFC[2:0]		
Initial value:	0	0	1	1	0	1	1	0	1	1	0	1	1	0	1	1
R/W:	R	R/W	R/W	R/W	R/W	R/W	R/W	R/W	R/W	R/W	R/W	R/W	R/W	R/W	R/W	R/W

Bit	Bit Name	Initial Value	R/W	Description
15	—	0	R	Reserved This bit is always read as 0. The write value should always be 0.
14 to 12	IFC[2:0]	011	R/W	Internal Clock ( $I\phi$ ) Frequency Division Ratio Specify the division ratio of the internal clock ( $I\phi$ ) frequency with respect to the output frequency of PLL circuit. If a prohibited value is specified, subsequent operation is not guaranteed. 000: Setting prohibited 001: $\times 1/2$ 010: Setting prohibited 011: $\times 1/4$ (initial value) 100: $\times 1/8$ Other than above: Setting prohibited
11 to 9	BFC[2:0]	011	R/W	Bus Clock ( $B\phi$ ) Frequency Division Ratio Specify the division ratio of the bus clock ( $B\phi$ ) frequency with respect to the output frequency of PLL circuit. If a prohibited value is specified, subsequent operation is not guaranteed. 000: Setting prohibited 001: $\times 1/2$ 010: Setting prohibited 011: $\times 1/4$ (initial value) 100: $\times 1/8$ Other than above: Setting prohibited

Bit	Bit Name	Initial Value	R/W	Description
8 to 6	PFC[2:0]	011	R/W	<p>Peripheral Clock (<math>P\phi</math>) Frequency Division Ratio</p> <p>Specify the division ratio of the peripheral clock (<math>P\phi</math>) frequency with respect to the output frequency of PLL circuit. If a prohibited value is specified, subsequent operation is not guaranteed.</p> <p>000: Setting prohibited</p> <p>001: <math>\times 1/2</math></p> <p>010: Setting prohibited</p> <p>011: <math>\times 1/4</math> (initial value)</p> <p>100: <math>\times 1/8</math></p> <p>Other than above: Setting prohibited</p>
5 to 3	—	011	R/W	<p>Reserved</p> <p>These bits are always read as B'011. The write value should always be B'011.</p>
2 to 0	MPFC[2:0]	011	R/W	<p>MTU2 Clock (<math>MP\phi</math>) Frequency Division Ratio</p> <p>Specify the division ratio of the MTU2 clock (<math>MP\phi</math>) frequency with respect to the output frequency of PLL circuit. If a prohibited value is specified, subsequent operation is not guaranteed.</p> <p>000: Setting prohibited</p> <p>001: <math>\times 1/2</math></p> <p>010: Setting prohibited</p> <p>011: <math>\times 1/4</math> (initial value)</p> <p>100: <math>\times 1/8</math></p> <p>Other than above: Setting prohibited</p>

#### 4.4.2 Oscillation Stop Detection Control Register (OSCCR)

OSCCR is an 8-bit readable/writable register that has an oscillation stop detection flag and selects flag status output to an external pin. OSCCR can be accessed only in bytes.

Bit:	7	6	5	4	3	2	1	0
	-	-	-	-	-	OSC STOP	-	OSC ERS
Initial value:	0	0	0	0	0	0	0	0
R/W:	R	R	R	R	R	R	R	R/W

Bit	Bit Name	Initial Value	R/W	Description
7 to 3	—	All 0	R	Reserved  These bits are always read as 0. The write value should always be 0.
2	OSCSTOP	0	R	Oscillation Stop Detection Flag [Setting condition] <ul style="list-style-type: none"> <li>When a stop in the clock input is detected during normal operation</li> </ul> [Clearing condition] <ul style="list-style-type: none"> <li>By a power-on reset input through the <math>\overline{\text{RES}}</math> pin</li> </ul>
1	—	0	R	Reserved  This bit is always read as 0. The write value should always be 0.
0	OSCERS	0	R/W	Oscillation Stop Detection Flag Output Select  Selects whether to output the oscillation stop detection flag signal through the $\overline{\text{WDTOVF}}$ pin.  0: Outputs only the WDT overflow signal through the $\overline{\text{WDTOVF}}$ pin  1: Outputs the WDT overflow signal and the oscillation stop detection flag signal through the $\overline{\text{WDTOVF}}$ pin

## 4.5 Changing Frequency

Selecting division ratios for the frequency divider can change the frequencies of the internal clock ( $I\phi$ ), bus clock ( $B\phi$ ), peripheral clock ( $P\phi$ ), and MTU2 clock ( $MP\phi$ ). This is controlled by software through the frequency control register (FRQCR). The following describes how to specify the frequencies.

1. In the initial state,  $IFC2$  to  $IFC0 = H'011$  ( $\times 1/4$ ),  $BFC2$  to  $BFC0 = H'011$  ( $\times 1/4$ ),  $PFC2$  to  $PFC0 = H'011$  ( $\times 1/4$ ), and  $MPFC2$  to  $MPFC0 = H'011$  ( $\times 1/4$ ).
2. Stop all modules except the CPU, on-chip ROM, and on-chip RAM.
3. Set the desired values in bits  $IFC2$  to  $IFC0$ ,  $BFC2$  to  $BFC0$ ,  $PFC2$  to  $PFC0$ , and  $MPFC2$  to  $MPFC0$  bits. Since the frequency multiplication ratio in the PLL circuit is fixed at  $\times 8$ , the frequencies are determined only by selecting division ratios. When specifying the frequencies, satisfy the following condition: internal clock ( $I\phi$ )  $\geq$  bus clock ( $B\phi$ ) = peripheral clock ( $P\phi$ ).  
When using the MTU2 clock, specify the frequencies to satisfy the following condition:  
internal clock ( $I\phi$ )  $\geq$  MTU2 clock ( $MP\phi$ )  $\geq$  peripheral clock ( $P\phi$ ).
4. After an instruction to rewrite FRQCR has been issued, the actual clock frequencies will change after  $(1 \text{ to } 24n) \text{ cyc} + 11B\phi + 7P\phi$ .  
n: Division ratio specified by the BFC bit in FRQCR (1/2, 1/4, or 1/8)  
cyc: Clock obtained by dividing EXTAL by 8 with the PLL.

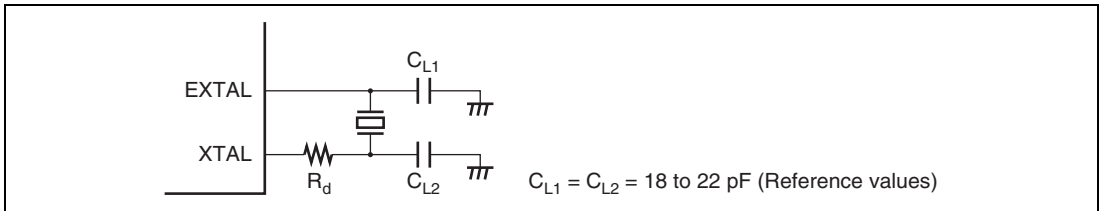
Note: (1 to 24n) depends on the internal state.

## 4.6 Oscillator

Clock pulses can be supplied from a connected crystal resonator or an external clock.

### 4.6.1 Connecting Crystal Resonator

A crystal resonator can be connected as shown in figure 4.2. Use the damping resistance ( $R_d$ ) listed in table 4.6. Use a crystal resonator that has a resonance frequency of 10 to 12.5 MHz. It is recommended to consult the crystal resonator manufacturer concerning the compatibility of the crystal resonator and the LSI.

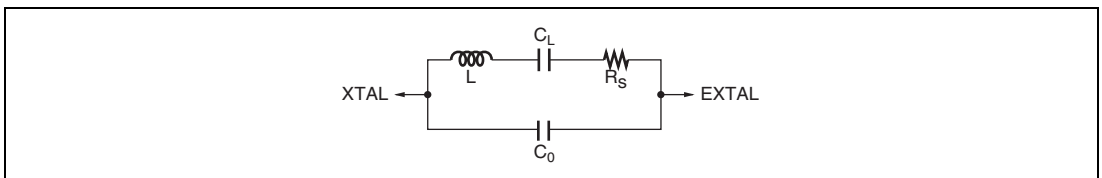


**Figure 4.2 Connection of Crystal Resonator (Example)**

**Table 4.6 Damping Resistance Values (Reference Values)**

Frequency (MHz)	10	12.5
$R_d$ ( $\Omega$ ) (Reference Values)	0	0

Figure 4.3 shows an equivalent circuit of the crystal resonator. Use a crystal resonator with the characteristics listed in table 4.7.



**Figure 4.3 Crystal Resonator Equivalent Circuit**

**Table 4.7 Crystal Resonator Characteristics**

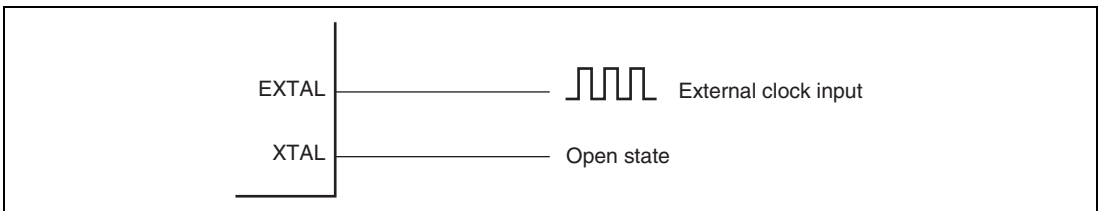
Frequency (MHz)	10	12.5
Rs Max. ( $\Omega$ ) (Reference Values)	60	50
Co Max. (pF) (Reference Values)	7	7

#### 4.6.2 External Clock Input Method

Figure 4.4 shows an example of an external clock input connection. In this case, make the external clock high level to stop it when in software standby mode. During operation, make the external input clock frequency 10 to 12.5 MHz.

When leaving the XTAL pin open, make sure the parasitic capacitance is less than 10 pF.

Even when inputting an external clock, be sure to wait at least the oscillation stabilization time in power-on sequence or in releasing software standby mode, in order to ensure the PLL stabilization time.



**Figure 4.4 Example of External Clock Connection**

## 4.7 Function for Detecting Oscillator Stop

This CPG detects a stop in the clock input if any system abnormality halts the clock supply.

When no change has been detected in the EXTAL input for a certain period, the OSCSTOP bit in OSCCR is set to 1 and this state is retained until a power-on reset is input through the  $\overline{\text{RES}}$  pin or software standby mode is canceled. If the  $\overline{\text{OSCERS}}$  bit is set to 1 at this time, an oscillation stop detection flag signal is output through the  $\overline{\text{WDTOVF}}$  pin. In addition, the high-current ports (pins to which the TIOC3B, TIOC3D, and TIOC4A to TIOC4D signals in the MTU2 are assigned) are always placed in high-impedance state regardless of the PFC setting. For details, refer to appendix A, Pin States.

Even in software standby mode, these pins are always placed in high-impedance state. For details, refer to appendix A, Pin States. These pins enter the normal state after software standby mode is canceled. Under an abnormal condition where oscillation stops while the LSI is not in software standby mode, LSI operations other than the oscillation stop detection function become unpredictable. In this case, even after oscillation is restarted, LSI operations including the above high-current pins become unpredictable.

Even while no change is detected in the EXTAL input, the PLL circuit in this LSI continues oscillating at a frequency range from 100 kHz to 10 MHz (depending on the temperature and operating voltage).



## 4.8 Usage Notes

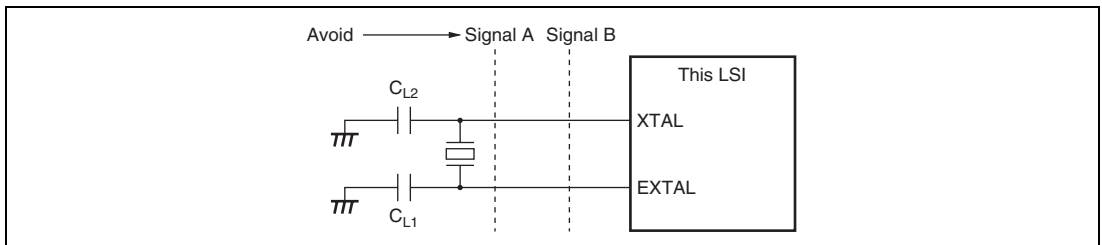
### 4.8.1 Note on Crystal Resonator

A sufficient evaluation at the user's site is necessary to use the LSI, by referring the resonator connection examples shown in this section, because various characteristics related to the crystal resonator are closely linked to the user's board design. As the oscillator circuit's circuit constant will depend on the resonator and the floating capacitance of the mounting circuit, the value of each external circuit's component should be determined in consultation with the resonator manufacturer. The design must ensure that a voltage exceeding the maximum rating is not applied to the oscillator pin.

### 4.8.2 Notes on Board Design

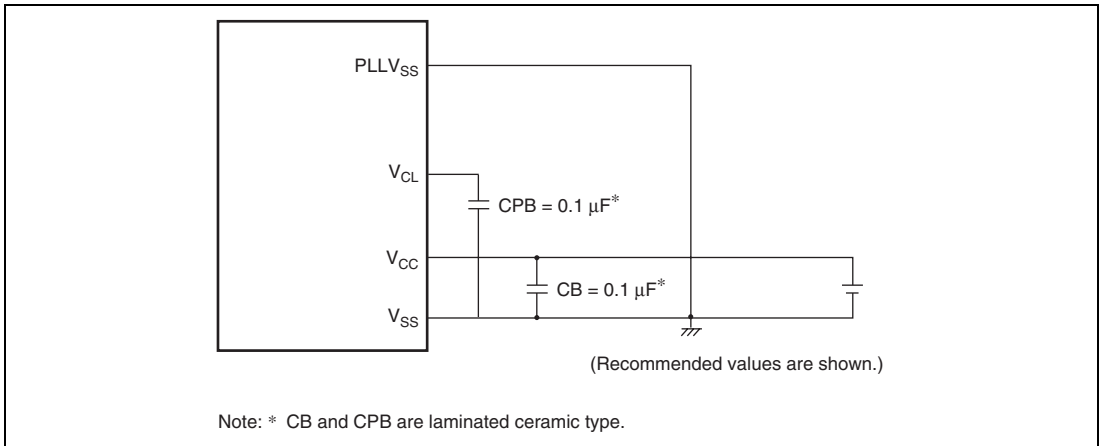
Measures against radiation noise are taken in this LSI. If further reduction in radiation noise is needed, it is recommended to use a multiple layer board and provide a layer exclusive to the system ground.

When using a crystal resonator, place the crystal resonator and its load capacitors as close as possible to the XTAL and EXTAL pins. Do not route any signal lines near the oscillator circuitry as shown in figure 4.5. Otherwise, correct oscillation can be interfered by induction.



**Figure 4.5 Cautions for Oscillator Circuit Board Design**

A circuitry shown in figure 4.6 is recommended as an external circuitry around the PLL. Separate the PLL power lines (PLL $V_{SS}$ ) and the system power lines ( $V_{CC}$ ,  $V_{SS}$ ) at the board power supply source, and be sure to insert bypass capacitors CB and CPB close to the pins.



**Figure 4.6 Recommended External Circuitry around PLL**

## Section 5 Exception Handling

### 5.1 Overview

#### 5.1.1 Types of Exception Handling and Priority

Exception handling is started by four sources: resets, address errors, interrupts and instructions and have the priority, as shown in table 5.1. When several exceptions are detected at once, they are processed according to the priority.

**Table 5.1 Types of Exceptions and Priority**

Exception	Exception Source	Priority
Reset	Power-on reset	
	Manual reset	
Interrupt	User break (break before instruction execution)	
Address error	CPU address error (instruction fetch)	
Instruction	General illegal instructions (undefined code)	
	Illegal slot instruction (undefined code placed immediately after a delayed branch instruction* <sup>1</sup> or instruction that changes the PC value* <sup>2</sup> )	
	Trap instruction (TRAPA instruction)	
Address error	CPU address error (data access)	
Interrupt	User break (break after instruction execution or operand break)	
	NMI	
	IRQ	
	On-chip peripheral modules	

Notes: 1. Delayed branch instructions: JMP, JSR, BRA, BSR, RTS, RTE, BF/S, BT/S, BSRF, and BRAF.

2. Instructions that change the PC value: JMP, JSR, BRA, BSR, RTS, RTE, BT, BF, TRAPA, BF/S, BT/S, BSRF, BRAF, LDC Rm,SR, LDC.L @Rm+,SR.

### 5.1.2 Exception Handling Operations

The exceptions are detected and the exception handling starts according to the timing shown in table 5.2.

**Table 5.2 Timing for Exception Detection and Start of Exception Handling**

Exception		Timing of Source Detection and Start of Exception Handling
Reset	Power-on reset	Started when the $\overline{\text{RES}}$ pin changes from low to high or when the WDT overflows.
	Manual reset	Started when the $\overline{\text{MRES}}$ pin changes from low to high or when the WDT overflows.
Address error		Detected during the instruction decode stage and started after the execution of the current instruction is completed.
Interrupt		
Instruction	Trap instruction	Started by the execution of the TRAPA instruction.
	General illegal instructions	Started when an undefined code placed at other than a delay slot (immediately after a delayed branch instruction) is decoded.
	Illegal slot instructions	Started when an undefined code placed at a delay slot (immediately after a delayed branch instruction) or an instruction that changes the PC value is detected.

When exception handling starts, the CPU operates

**Exception Handling Triggered by Reset:** The initial values of the program counter (PC) and stack pointer (SP) are fetched from the exception handling vector table (PC from the address H'00000000 and SP from the address H'00000004 when a power-on reset. PC from the address H'00000008 and SP from the address H'0000000C when a manual reset.). For details, see section 5.1.3, Exception Handling Vector Table. H'00000000 is then written to the vector base register (VBR), and H'F (B'1111) is written to the interrupt mask bits (I3 to I0) in the status register (SR). The program starts from the PC address fetched from the exception handling vector table.

**Exception Handling Triggered by Address Error, Interrupt, and Instruction:** SR and PC are saved to the stack indicated by R15. For interrupt exception handling, the interrupt priority level is written to the interrupt mask bits (I3 to I0) in SR. For address error and instruction exception handling, bits I3 to I0 are not affected. The start address is then fetched from the exception handling vector table and the program starts from that address.

### 5.1.3 Exception Handling Vector Table

Before exception handling starts, the exception handling vector table must be set in memory. The exception handling vector table stores the start addresses of exception handling routines. (The reset exception handling table holds the initial values of PC and SP.)

All exception sources are given different vector numbers and vector table address offsets. The vector table addresses are calculated from these vector numbers and vector table address offsets. During exception handling, the start addresses of the exception handling routines are fetched from the exception handling vector table that is indicated by this vector table address.

Table 5.3 shows the vector numbers and vector table address offsets. Table 5.4 shows how vector table addresses are calculated.

**Table 5.3 Vector Numbers and Vector Table Address Offsets**

Exception Handling Source		Vector Number	Vector Table Address Offset
Power-on reset	PC	0	H'00000000 to H'00000003
	SP	1	H'00000004 to H'00000007
Manual reset	PC	2	H'00000008 to H'0000000B
	SP	3	H'0000000C to H'0000000F
General illegal instruction		4	H'00000010 to H'00000013
(Reserved for system use)		5	H'00000014 to H'00000017
Illegal slot instruction		6	H'00000018 to H'0000001B
(Reserved for system use)		7	H'0000001C to H'0000001F
		8	H'00000020 to H'00000023
CPU address error		9	H'00000024 to H'00000027
(Reserved for system use)		10	H'00000028 to H'0000002B
Interrupt	NMI	11	H'0000002C to H'0000002F
	User break	12	H'00000030 to H'00000033
(Reserved for system use)		13	H'00000034 to H'00000037
		:	:
		31	H'0000007C to H'0000007F
Trap instruction (user vector)		32	H'00000080 to H'00000083
		:	:
		63	H'000000FC to H'000000FF

Exception Handling Source		Vector Number	Vector Table Address Offset
Interrupt	IRQ0 (SH7125)	64	H'00000100 to H'00000103
	IRQ1	65	H'00000104 to H'00000107
	IRQ2	66	H'00000108 to H'0000010B
	IRQ3	67	H'0000010C to H'0000010F
(Reserved for system use)		68	H'00000110 to H'00000113
		:	:
		71	H'0000011C to H'0000011F
On-chip peripheral module*		72	H'00000120 to H'00000123
		:	:
		255	H'000003FC to H'000003FF

Note: \* For details on the vector numbers and vector table address offsets of on-chip peripheral module interrupts, see table 6.3 in section 6, Interrupt Controller (INTC).

**Table 5.4 Calculating Exception Handling Vector Table Addresses**

Exception Source	Vector Table Address Calculation
Resets	Vector table address = (vector table address offset) = (vector number) × 4
Address errors, interrupts, instructions	Vector table address = VBR + (vector table address offset) = VBR + (vector number) × 4

- Notes: 1. VBR: Vector base register  
2. Vector table address offset: See table 5.3.  
3. Vector number: See table 5.3.

## 5.2 Resets

### 5.2.1 Types of Resets

Resets have priority over any exception source. There are two types of resets: power-on resets and manual resets. As table 5.5 shows, both types of resets initialize the internal status of the CPU. In power-on resets, all registers of the on-chip peripheral modules are initialized; in manual resets, they are not.

**Table 5.5 Reset Status**

Type	Conditions for Transition to Reset State			Internal State		
	$\overline{\text{RES}}$	WDT Overflow	$\overline{\text{MRES}}$	CPU, INTC	On-Chip Peripheral Module	POE, PFC, I/O Port
Power-on reset	Low	—	—	Initialized	Initialized	Initialized
	High	Overflow	High	Initialized	Initialized	Initialized
Manual reset	High	Not overflowed	Low	Initialized	Not initialized	Not initialized
	High	Overflow	High	Initialized	Not initialized	Not initialized

### 5.2.2 Power-On Reset

**Power-On Reset by  $\overline{\text{RES}}$  Pin:** When the  $\overline{\text{RES}}$  pin is driven low, this LSI enters the power-on reset state. To reliably reset this LSI, the  $\overline{\text{RES}}$  pin should be kept low for at least the oscillation settling time when applying the power or when in standby mode (when the clock is halted) or at least 20 tcyc when the clock is operating. During the power-on reset state, CPU internal states and all registers of on-chip peripheral modules are initialized. See appendix A, Pin States, for the status of individual pins during power-on reset mode.

In the power-on reset state, power-on reset exception handling starts when driving the  $\overline{\text{RES}}$  pin high after driving the pin low for the given time. The CPU operates as follows:

1. The initial value (execution start address) of the program counter (PC) is fetched from the exception handling vector table.
2. The initial value of the stack pointer (SP) is fetched from the exception handling vector table.
3. The vector base register (VBR) is cleared to H'00000000 and the interrupt mask bits (I3 to I0) of the status register (SR) are set to H'F (B'1111).

4. The values fetched from the exception handling vector table are set in PC and SP, then the program starts.

Be certain to always perform power-on reset exception handling when turning the system power on.

**Power-On Reset by WDT:** When WTCNT of the WDT overflows while a setting is made so that a power-on reset can be generated in watchdog timer mode of the WDT, this LSI enters the power-on reset state.

The frequency control register (FRQCR) in the clock pulse generator (CPG) and the watchdog timer (WDT) registers are not initialized by a reset generated by the WDT (these registers are only initialized by a power-on reset from the  $\overline{\text{RES}}$  pin).

If a reset caused by the signal input on the  $\overline{\text{RES}}$  pin and a reset caused by a WDT overflow occur simultaneously, the  $\overline{\text{RES}}$  pin reset has priority, and the WOVF bit in RSTCSR is cleared to 0. When the power-on reset exception handling caused by the WDT is started, the CPU operates as follows:

1. The initial value (execution start address) of the program counter (PC) is fetched from the exception handling vector table.
2. The initial value of the stack pointer (SP) is fetched from the exception handling vector table.
3. The vector base register (VBR) is cleared to H'00000000 and the interrupt mask bits (I3 to I0) of the status register (SR) are set to H'F (B'1111).
4. The values fetched from the exception handling vector table are set in the PC and SP, then the program starts.

### 5.2.3 Manual Reset

When the  $\overline{\text{RES}}$  pin is high and the  $\overline{\text{MRES}}$  pin is driven low, the LSI becomes to be a manual reset state. To reliably reset the LSI, the  $\overline{\text{MRES}}$  pin should be kept at low for at least the duration of the oscillation settling time that is set in WDT when in software standby mode (when the clock is halted) or at least  $20 t_{\text{cyc}}$  when the clock is operating. During manual reset, the CPU internal status is initialized. Registers of on-chip peripheral modules are not initialized. See appendix A, Pin States, for the status of individual pins during manual reset mode.

In the manual reset status, manual reset exception processing starts when the  $\overline{\text{MRES}}$  pin is first kept low for a set period of time and then returned to high. The CPU will then operate in the same procedures as described for power-on resets.



## 5.3 Address Errors

### 5.3.1 Address Error Sources

Address errors occur when instructions are fetched or data is read from or written to, as shown in table 5.6.

**Table 5.6 Bus Cycles and Address Errors**

Bus Cycle			
Type	Bus Master	Bus Cycle Description	Address Errors
Instruction fetch	CPU	Instruction fetched from even address	None (normal)
		Instruction fetched from odd address	Address error occurs
		Instruction fetched from a space other than on-chip peripheral module space	None (normal)
		Instruction fetched from on-chip peripheral module space	Address error occurs
Data read/write	CPU	Word data accessed from even address	None (normal)
		Word data accessed from odd address	Address error occurs
		Longword data accessed from a longword boundary	None (normal)
		Longword data accessed from other than a long-word boundary	Address error occurs
		Byte or word data accessed in on-chip peripheral module space	None (normal)
		Longword data accessed in 16-bit on-chip peripheral module space	None (normal)
		Longword data accessed in 8-bit on-chip peripheral module space	None (normal)

### 5.3.2 Address Error Exception Source

When an address error exception is generated, the bus cycle which caused the address error ends, the current instruction finishes, and then the address error exception handling starts. The CPU operates as follows:

1. The status register (SR) is saved to the stack.
2. The program counter (PC) is saved to the stack. The PC value to be saved is the start address of the instruction which caused an address error exception. When the instruction that caused the exception is placed in the delay slot, the address of the delayed branch instruction which is placed immediately before the delay slot.
3. The start address of the exception handling routine is fetched from the exception handling vector table that corresponds to the generated address error, and the program starts executing from that address. This branch is not a delayed branch.

## 5.4 Interrupts

### 5.4.1 Interrupt Sources

Table 5.7 shows the sources that start the interrupt exception handling. They are NMI, user break, IRQ, and on-chip peripheral modules.

**Table 5.7 Interrupt Sources**

Type	Request Source	Number of Sources
NMI	NMI pin (external input)	1
User break	User break controller (UBC)	1
IRQ	IRQ0 to IRQ3 pins (external input)	4 (SH7125)
		3 (SH7124)
On-chip peripheral module	Multi-function timer pulse unit 2 (MTU2)	28
	Watchdog timer (WDT)	1
	A/D converter (A/D_0 and A/D_1)	2
	Compare match timer (CMT_0 and CMT_1)	2
	Serial communication interface (SCI_0, SCI_1, and SCI_2)	12
	Port output enable (POE)	2

All interrupt sources are given different vector numbers and vector table address offsets. For details on vector numbers and vector table address offsets, see table 6.3 in section 6, Interrupt Controller (INTC).

## 5.4.2 Interrupt Priority

The interrupt priority is predetermined. When multiple interrupts occur simultaneously (overlapped interruptions), the interrupt controller (INTC) determines their relative priorities and starts the exception handling according to the results.

The priority of interrupts is expressed as priority levels 0 to 16, with priority 0 the lowest and priority 16 the highest. The NMI interrupt has priority 16 and cannot be masked, so it is always accepted. The priority level of the user break interrupt is 15. IRQ interrupt and on-chip peripheral module interrupt priority levels can be set freely using the interrupt priority registers A to F and H to M (IPRA to IPRF and IPRH to IPRM) of the INTC as shown in table 5.8. The priority levels that can be set are 0 to 15. Level 16 cannot be set. For details on IPRA to IPRF, see section 6.3.4, Interrupt Priority Registers A to F and H to M (IPRA to IPRF and IPRH to IPRM).

**Table 5.8 Interrupt Priority**

Type	Priority Level	Comment
NMI	16	Fixed priority level. Cannot be masked.
User break	15	Fixed priority level. Can be masked.
IRQ	0 to 15	Set with interrupt priority registers A to F and H to M (IPRA to IPRF and IPRH to IPRM).
On-chip peripheral module		

## 5.4.3 Interrupt Exception Handling

When an interrupt occurs, the interrupt controller (INTC) ascertains its priority level. NMI is always accepted, but other interrupts are only accepted if they have a priority level higher than the priority level set in the interrupt mask bits (I3 to I0) of the status register (SR).

When an interrupt is accepted, exception handling begins. In interrupt exception handling, the CPU saves SR and the program counter (PC) to the stack. The priority level of the accepted interrupt is written to bits I3 to I0 in SR. Although the priority level of the NMI is 16, the value set in bits I3 to I0 is H'F (level 15). Next, the start address of the exception handling routine is fetched from the exception handling vector table for the accepted interrupt, and program execution branches to that address and the program starts. For details on the interrupt exception handling, see section 6.6, Interrupt Operation.

## 5.5 Exceptions Triggered by Instructions

### 5.5.1 Types of Exceptions Triggered by Instructions

Exception handling can be triggered by the trap instruction, illegal slot instructions, and general illegal instructions, as shown in table 5.9.

**Table 5.9** Types of Exceptions Triggered by Instructions

Type	Source Instruction	Comment
Trap instruction	TRAPA	—
Illegal slot instructions*	Undefined code placed immediately after a delayed branch instruction (delay slot) or instructions that changes the PC value	Delayed branch instructions: JMP, JSR, BRA, BSR, RTS, RTE, BF/S, BT/S, BSRF, BRAF Instructions that changes the PC value: JMP, JSR, BRA, BSR, RTS, RTE, BT, BF, TRAPA, BF/S, BT/S, BSRF, BRAF, LDC Rm,SR, LDC.L @Rm+,SR
General illegal instructions*	Undefined code anywhere besides in a delay slot	—

Note: \* The operation is not guaranteed when undefined instructions other than H'F000 to H'FFFF are decoded.

### 5.5.2 Trap Instructions

When a TRAPA instruction is executed, the trap instruction exception handling starts. The CPU operates as follows:

1. The status register (SR) is saved to the stack.
2. The program counter (PC) is saved to the stack. The PC value saved is the start address of the instruction to be executed after the TRAPA instruction.
3. The CPU reads the start address of the exception handling routine from the exception handling vector table that corresponds to the vector number specified in the TRAPA instruction, program execution branches to that address, and then the program starts. This branch is not a delayed branch.

### 5.5.3 Illegal Slot Instructions

An instruction placed immediately after a delayed branch instruction is called "instruction placed in a delay slot". When the instruction placed in the delay slot is an undefined code, illegal slot exception handling starts after the undefined code is decoded. Illegal slot exception handling also starts when an instruction that changes the program counter (PC) value is placed in a delay slot and the instruction is decoded. The CPU handles an illegal slot instruction as follows:

1. The status register (SR) is saved to the stack.
2. The program counter (PC) is saved to the stack. The PC value saved is the target address of the delayed branch instruction immediately before the undefined code or the instruction that rewrites the PC.
3. The start address of the exception handling routine is fetched from the exception handling vector table that corresponds to the exception that occurred. Program execution branches to that address and the program starts. This branch is not a delayed branch.

### 5.5.4 General Illegal Instructions

When an undefined code placed anywhere other than immediately after a delayed branch instruction (i.e., in a delay slot) is decoded, general illegal instruction exception handling starts. The CPU handles the general illegal instructions in the same procedures as in the illegal slot instructions. Unlike processing of illegal slot instructions, however, the program counter value that is stacked is the start address of the undefined code.

## 5.6 Cases when Exceptions are Accepted

When an exception other than resets occurs during decoding the instruction placed in a delay slot or immediately after an interrupt disabled instruction, it may not be accepted and be held shown in table 5.10. In this case, when an instruction which accepts an interrupt request is decoded, the exception is accepted.

**Table 5.10 Delay Slot Instructions, Interrupt Disabled Instructions, and Exceptions**

Occurrence Timing	Exception				
	Address Error	General Illegal Instruction	Slot Illegal Instruction	Trap Instruction	Interrupt
Instruction in delay slot	×* <sup>2</sup>	—	×* <sup>2</sup>	—	×* <sup>3</sup>
Immediately after interrupt disabled instruction* <sup>1</sup>	√	√	√	√	×* <sup>4</sup>

[Legend]

√: Accepted

×: Not accepted

—: Does not occur

- Notes:
1. Interrupt disabled instructions: LDC, LDC.L, STC, STC.L, LDS, LDS.L, STS, and STS.L
  2. An exception is accepted before the execution of a delayed branch instruction. However, when an address error or a slot illegal instruction exception occurs in the delay slot of the RTE instruction, correct operation is not guaranteed.
  3. An exception is accepted after a delayed branch (between instructions in the delay slot and the branch destination).
  4. An exception is accepted after the execution of the next instruction of an interrupt disabled instruction (before the execution two instructions after an interrupt disabled instruction).

## 5.7 Stack States after Exception Handling Ends

The stack states after exception handling ends are shown in table 5.11.

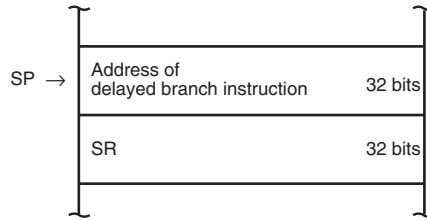
**Table 5.11 Stack Status after Exception Handling Ends**

Types	Stack State				
Address error (when the instruction that caused an exception is placed in the delay slot)	<p>SP →</p> <table border="1" style="margin-left: 20px;"> <tr> <td style="width: 60%;">Address of delayed branch instruction</td> <td style="width: 40%;">32 bits</td> </tr> <tr> <td>SR</td> <td>32 bits</td> </tr> </table>	Address of delayed branch instruction	32 bits	SR	32 bits
Address of delayed branch instruction	32 bits				
SR	32 bits				
Address error (other than above)	<p>SP →</p> <table border="1" style="margin-left: 20px;"> <tr> <td style="width: 60%;">Address of instruction that caused exception</td> <td style="width: 40%;">32 bits</td> </tr> <tr> <td>SR</td> <td>32 bits</td> </tr> </table>	Address of instruction that caused exception	32 bits	SR	32 bits
Address of instruction that caused exception	32 bits				
SR	32 bits				
Interrupt	<p>SP →</p> <table border="1" style="margin-left: 20px;"> <tr> <td style="width: 60%;">Address of instruction after executed instruction</td> <td style="width: 40%;">32 bits</td> </tr> <tr> <td>SR</td> <td>32 bits</td> </tr> </table>	Address of instruction after executed instruction	32 bits	SR	32 bits
Address of instruction after executed instruction	32 bits				
SR	32 bits				
Trap instruction	<p>SP →</p> <table border="1" style="margin-left: 20px;"> <tr> <td style="width: 60%;">Address of instruction after TRAPA instruction</td> <td style="width: 40%;">32 bits</td> </tr> <tr> <td>SR</td> <td>32 bits</td> </tr> </table>	Address of instruction after TRAPA instruction	32 bits	SR	32 bits
Address of instruction after TRAPA instruction	32 bits				
SR	32 bits				

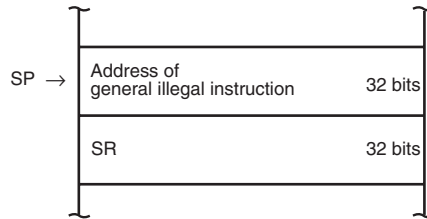


**Types****Stack State**

Illegal slot instruction



General illegal instruction



## 5.8 Usage Notes

### 5.8.1 Value of Stack Pointer (SP)

The SP value must always be a multiple of 4. If it is not, an address error will occur when the stack is accessed during exception handling.

### 5.8.2 Value of Vector Base Register (VBR)

The VBR value must always be a multiple of 4. If it is not, an address error will occur when the stack is accessed during exception handling.

### 5.8.3 Address Errors Caused by Stacking for Address Error Exception Handling

When the SP value is not a multiple of 4, an address error will occur when stacking for exception handling (interrupts, etc.) and address error exception handling will start after the first exception handling is ended. Address errors will also occur in the stacking for this address error exception handling. To ensure that address error exception handling does not go into an endless loop, no address errors are accepted at that point. This allows program control to be passed to the handling routine for address error exception and enables error processing.

When an address error occurs during exception handling stacking, the stacking bus cycle (write) is executed. When stacking the SR and PC values, the SP values for both are subtracted by 4, therefore, the SP value is still not a multiple of 4 after the stacking. The address value output during stacking is the SP value whose lower two bits are cleared to 0. So the write data stacked is undefined.

### 5.8.4 Notes on Slot Illegal Instruction Exception Handling

Some specifications on slot illegal instruction exception handling in this LSI differ from those of the conventional SH-2.

- Conventional SH-2: Instructions LDC Rm,SR and LDC.L @Rm+,SR are not subject to the slot illegal instructions.
- This LSI: Instructions LDC Rm,SR and LDC.L @Rm+,SR are subject to the slot illegal instructions.

The supporting status on our software products regarding this note is as follows:

#### Compiler

This instruction is not allocated in the delay slot in the compiler V.4 and its subsequent versions.

#### Real-time OS for $\mu$ TRON specifications

1. HI7000/4, HI-SH7

This instruction does not exist in the delay slot within the OS.

2. HI7000

This instruction is in part allocated to the delay slot within the OS, which may cause the slot illegal instruction exception handling in this LSI.

3. Others

The slot illegal instruction exception handling may be generated in this LSI in a case where the instruction is described in assembler or when the middleware of the object is introduced.

Note that a check-up program (checker) to pick up this instruction is available on our website. Download and utilize this checker as needed.



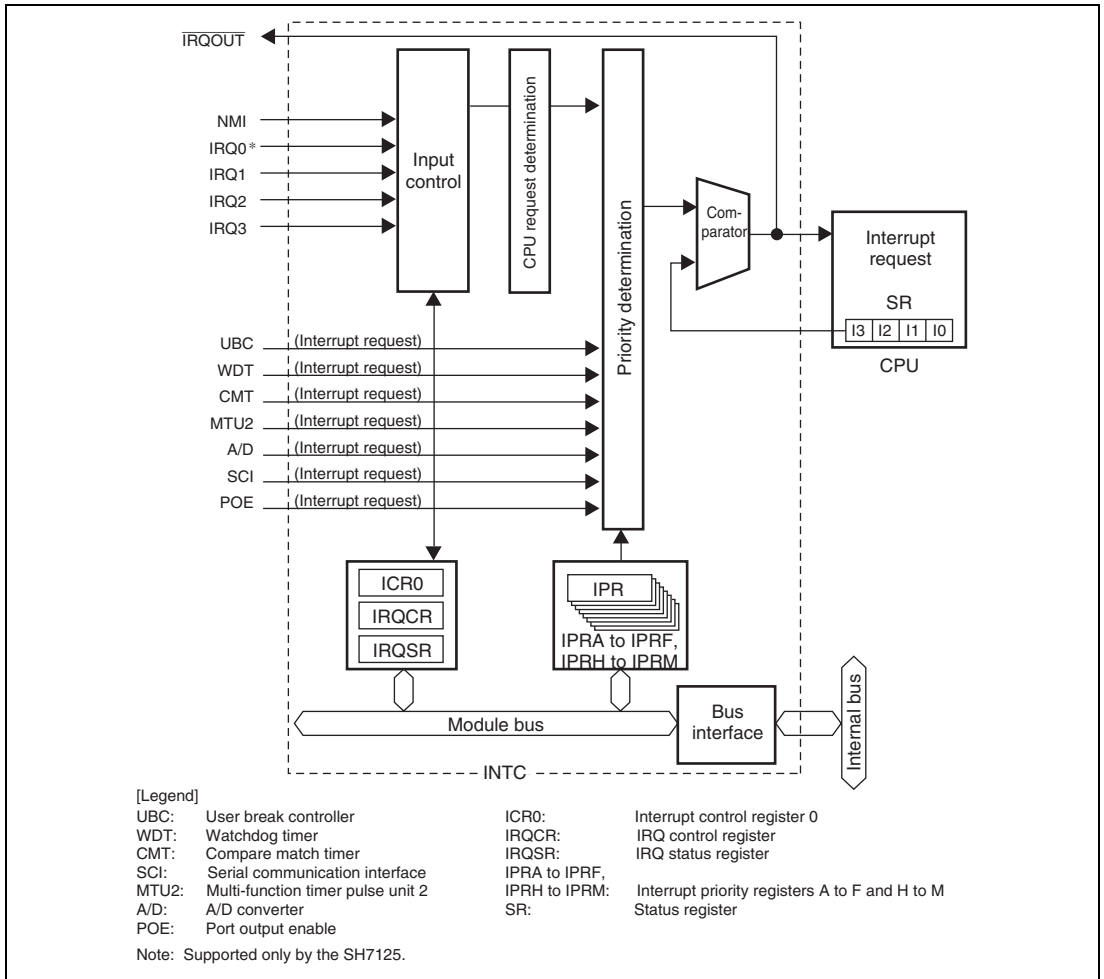
## Section 6 Interrupt Controller (INTC)

The interrupt controller (INTC) ascertains the priority of interrupt sources and controls interrupt requests to the CPU.

### 6.1 Features

- 16 levels of interrupt priority
- NMI noise canceller function
- Occurrence of interrupt can be reported externally ( $\overline{\text{IRQOUT}}$  pin)

Figure 6.1 shows a block diagram of the INTC.



**Figure 6.1 Block Diagram of INTC**

## 6.2 Input/Output Pins

Table 6.1 shows the INTC pin configuration.

**Table 6.1 Pin Configuration**

<b>Name</b>	<b>Abbr.</b>	<b>I/O</b>	<b>Function</b>
Non-maskable interrupt input pin	NMI	Input	Input of non-maskable interrupt request signal
Interrupt request input pins	IRQ0 to IRQ3	Input	Input of maskable interrupt request signals
Interrupt request output pin	$\overline{\text{IRQOUT}}$	Output	Output of notification signal when an interrupt has occurred

## 6.3 Register Descriptions

The interrupt controller has the following registers. For details on the addresses of these registers and the states of these registers in each processing state, see section 20, List of Registers.

**Table 6.2 Register Configuration**

Register Name	Abbreviation	R/W	Initial Value	Address	Access Size
Interrupt control register 0	ICR0	R/W	H'x000	H'FFFFE900	8, 16
IRQ control register	IRQCR	R/W	H'0000	H'FFFFE902	8, 16
IRQ status register	IRQSR	R/W	H'Fx00	H'FFFFE904	8, 16
Interrupt priority register A	IPRA	R/W	H'0000	H'FFFFE906	8, 16
Interrupt priority register B	IPRB	R/W	H'0000	H'FFFFE908	8, 16
Interrupt priority register C	IPRC	R/W	H'0000	H'FFFFE980	16
Interrupt priority register D	IPRD	R/W	H'0000	H'FFFFE982	16
Interrupt priority register E	IPRE	R/W	H'0000	H'FFFFE984	16
Interrupt priority register F	IPRF	R/W	H'0000	H'FFFFE986	16
Interrupt priority register H	IPRH	R/W	H'0000	H'FFFFE98A	16
Interrupt priority register I	IPRI	R/W	H'0000	H'FFFFE98C	16
Interrupt priority register J	IPRJ	R/W	H'0000	H'FFFFE98E	16
Interrupt priority register K	IPRK	R/W	H'0000	H'FFFFE990	16
Interrupt priority register L	IPRL	R/W	H'0000	H'FFFFE992	16
Interrupt priority register M	IPRM	R/W	H'0000	H'FFFFE994	16



### 6.3.1 Interrupt Control Register 0 (ICR0)

ICR0 is a 16-bit register that sets the input signal detection mode of the external interrupt input pin NMI and indicates the input signal level on the NMI pin.

Bit:	15	14	13	12	11	10	9	8	7	6	5	4	3	2	1	0
	NMIL	-	-	-	-	-	-	NMIE	-	-	-	-	-	-	-	-
Initial value:	*	0	0	0	0	0	0	0	0	0	0	0	0	0	0	0
R/W:	R	R	R	R	R	R	R	R/W	R	R	R	R	R	R	R	R

Note: \* The initial value is 1 when the level on the NMI pin is high, and 0 when the level on the pin is low.

Bit	Bit Name	Initial Value	R/W	Description
15	NMIL	*	R	<p>NMI Input Level</p> <p>Indicates the state of the signal input to the NMI pin. This bit can be read to determine the NMI pin level. This bit cannot be modified.</p> <p>0: State of the NMI input is low 1: State of the NMI input is high</p>
14 to 9	—	All 0	R	<p>Reserved</p> <p>These bits are always read as 0. The write value should always be 0.</p>
8	NMIE	0	R/W	<p>NMI Edge Select</p> <p>0: Interrupt request is detected on the falling edge of the NMI input 1: Interrupt request is detected on the rising edge of the NMI input</p>
7 to 0	—	All 0	R	<p>Reserved</p> <p>These bits are always read as 0. The write value should always be 0.</p>

### 6.3.2 IRQ Control Register (IRQCR)

IRQCR is a 16-bit register that sets the input signal detection mode of the external interrupt input pins IRQ0 to IRQ3.

Bit:	15	14	13	12	11	10	9	8	7	6	5	4	3	2	1	0
	-	-	-	-	-	-	-	-	IRQ31S	IRQ30S	IRQ21S	IRQ20S	IRQ11S	IRQ10S	IRQ01S	IRQ00S
Initial value:	0	0	0	0	0	0	0	0	0	0	0	0	0	0	0	0
R/W:	R/W	R/W	R/W	R/W	R/W	R/W	R/W	R/W	R/W	R/W	R/W	R/W	R/W	R/W	R/W	R/W

Bit	Bit Name	Initial Value	R/W	Description
15 to 8	—	All 0	R/W	Reserved These bits are always read as 0. The write value should always be 0.
7	IRQ31S	0	R/W	IRQ3 Sense Select
6	IRQ30S	0	R/W	Set the interrupt request detection mode for pin IRQ3. 00: Interrupt request is detected at the low level of pin IRQ3 01: Interrupt request is detected at the falling edge of pin IRQ3 10: Interrupt request is detected at the rising edge of pin IRQ3 11: Interrupt request is detected at both the falling and rising edges of pin IRQ3
5	IRQ21S	0	R/W	IRQ2 Sense Select
4	IRQ20S	0	R/W	Set the interrupt request detection mode for pin IRQ2. 00: Interrupt request is detected at the low level of pin IRQ2 01: Interrupt request is detected at the falling edge of pin IRQ2 10: Interrupt request is detected at the rising edge of pin IRQ2 11: Interrupt request is detected at both the falling and rising edges of pin IRQ2

Bit	Bit Name	Initial Value	R/W	Description
3	IRQ11S	0	R/W	IRQ1 Sense Select
2	IRQ10S	0	R/W	Set the interrupt request detection mode for pin IRQ1. 00: Interrupt request is detected at the low level of pin IRQ1 01: Interrupt request is detected at the falling edge of pin IRQ1 10: Interrupt request is detected at the rising edge of pin IRQ1 11: Interrupt request is detected at both the falling and rising edges of pin IRQ1
1	IRQ01S	0	R/W	IRQ0 Sense Select (SH7125)
0	IRQ00S	0	R/W	Set the interrupt request detection mode for pin IRQ0. 00: Interrupt request is detected at the low level of pin IRQ0 01: Interrupt request is detected at the falling edge of pin IRQ0 10: Interrupt request is detected at the rising edge of pin IRQ0 11: Interrupt request is detected at both the falling and rising edges of pin IRQ0 Reserved (SH7124) These bits are always read as 0. The write value should always be 0.

### 6.3.3 IRQ Status register (IRQSR)

IRQSR is a 16-bit register that indicates the states of the external interrupt input pins IRQ0 to IRQ3 and the status of interrupt request.

Bit:	15	14	13	12	11	10	9	8	7	6	5	4	3	2	1	0
	-	-	-	-	IRQ3L	IRQ2L	IRQ1L	IRQ0L	-	-	-	-	IRQ3F	IRQ2F	IRQ1F	IRQ0F
Initial value:	1	1	1	1	*	*	*	*	0	0	0	0	0	0	0	0
R/W:	R	R	R	R	R	R	R	R	R/W	R/W	R/W	R/W	R/W	R/W	R/W	R/W

Note: \* The initial value is 1 when the level on the corresponding IRQ pin is high, and 0 when the level on the pin is low.

Bit	Bit Name	Initial Value	R/W	Description
15 to 12	—	All 1	R	Reserved These bits are always read as 1.
11	IRQ3L	*	R	Indicates the state of pin IRQ3. 0: State of pin IRQ3 is low 1: State of pin IRQ3 is high
10	IRQ2L	*	R	Indicates the state of pin IRQ2. 0: State of pin IRQ2 is low 1: State of pin IRQ2 is high
9	IRQ1L	*	R	Indicates the state of pin IRQ1. 0: State of pin IRQ1 is low 1: State of pin IRQ1 is high
8	IRQ0L	*	R	Indicates the state of pin IRQ0. 0: State of pin IRQ0 is low 1: State of pin IRQ0 is high
7 to 4	—	All 0	—	Reserved These bits are always read as 0. The write value should always be 0.

Bit	Bit Name	Initial Value	R/W	Description
3	IRQ3F	0	R/W	<p>Indicates the status of an IRQ3 interrupt request.</p> <ul style="list-style-type: none"> <li>When level detection mode is selected</li> </ul> <p>0: An IRQ3 interrupt has not been detected [Clearing condition] Driving pin IRQ3 high</p> <p>1: An IRQ3 interrupt has been detected [Setting condition] Driving pin IRQ3 low</p> <ul style="list-style-type: none"> <li>When edge detection mode is selected</li> </ul> <p>0: An IRQ3 interrupt has not been detected [Clearing conditions]</p> <ul style="list-style-type: none"> <li>— Writing 0 after reading IRQ3F = 1</li> <li>— Accepting an IRQ3 interrupt</li> </ul> <p>1: An IRQ3 interrupt request has been detected [Setting condition] Detecting the specified edge of pin IRQ3</p>

Bit	Bit Name	Initial Value	R/W	Description
2	IRQ2F	0	R/W	<p>Indicates the status of an IRQ2 interrupt request.</p> <ul style="list-style-type: none"> <li>When level detection mode is selected</li> </ul> <p>0: An IRQ2 interrupt has not been detected [Clearing condition] Driving pin IRQ2 high</p> <p>1: An IRQ2 interrupt has been detected [Setting condition] Driving pin IRQ2 low</p> <ul style="list-style-type: none"> <li>When edge detection mode is selected</li> </ul> <p>0: An IRQ2 interrupt has not been detected [Clearing conditions]</p> <ul style="list-style-type: none"> <li>— Writing 0 after reading IRQ2F = 1</li> <li>— Accepting an IRQ2 interrupt</li> </ul> <p>1: An IRQ2 interrupt request has been detected [Setting condition] Detecting the specified edge of pin IRQ2</p>
1	IRQ1F	0	R/W	<p>Indicates the status of an IRQ1 interrupt request.</p> <ul style="list-style-type: none"> <li>When level detection mode is selected</li> </ul> <p>0: An IRQ1 interrupt has not been detected [Clearing condition] Driving pin IRQ1 high</p> <p>1: An IRQ1 interrupt has been detected [Setting condition] Driving pin IRQ1 low</p> <ul style="list-style-type: none"> <li>When edge detection mode is selected</li> </ul> <p>0: An IRQ1 interrupt has not been detected [Clearing conditions]</p> <ul style="list-style-type: none"> <li>— Writing 0 after reading IRQ1F = 1</li> <li>— Accepting an IRQ1 interrupt</li> </ul> <p>1: An IRQ1 interrupt request has been detected [Setting condition] Detecting the specified edge of pin IRQ1</p>

Bit	Bit Name	Initial Value	R/W	Description
0	IRQ0F	0	R/W	<p>Indicates the status of an IRQ0 interrupt request.</p> <ul style="list-style-type: none"> <li>When level detection mode is selected</li> </ul> <p>0: An IRQ0 interrupt has not been detected [Clearing condition] Driving pin IRQ0 high</p> <p>1: An IRQ0 interrupt has been detected [Setting condition] Driving pin IRQ0 low</p> <ul style="list-style-type: none"> <li>When edge detection mode is selected</li> </ul> <p>0: An IRQ0 interrupt has not been detected [Clearing conditions]</p> <ul style="list-style-type: none"> <li>— Writing 0 after reading IRQ0F = 1</li> <li>— Accepting an IRQ0 interrupt</li> </ul> <p>1: An IRQ0 interrupt request has been detected [Setting condition] Detecting the specified edge of pin IRQ0</p>

Note: \* The initial value is 1 when the level on the corresponding IRQ pin is high, and 0 when the level on the pin is low.

### 6.3.4 Interrupt Priority Registers A to F and H to M (IPRA to IPRF and IPRH to IPRM)

Interrupt priority registers are twelve 16-bit readable/writable registers that set priority levels from 0 to 15 for interrupts except NMI. For the correspondence between interrupt request sources and IPR, refer to table 6.3. Each of the corresponding interrupt priority ranks are established by setting a value from H'0 to H'F in each of the four-bit groups 15 to 12, 11 to 8, 7 to 4 and 3 to 0. Reserved bits that are not assigned should be set H'0 (B'0000).

Bit:	15	14	13	12	11	10	9	8	7	6	5	4	3	2	1	0
	IPR[15:12]				IPR[11:8]				IPR[7:4]				IPR[3:0]			
Initial value:	0	0	0	0	0	0	0	0	0	0	0	0	0	0	0	0
R/W:	R/W	R/W	R/W	R/W	R/W	R/W	R/W	R/W	R/W	R/W	R/W	R/W	R/W	R/W	R/W	R/W

Bit	Bit Name	Initial Value	R/W	Description
15 to 12	IPR[15:12]	0000	R/W	<p>Set priority levels for the corresponding interrupt source.</p> <p>0000: Priority level 0 (lowest)  0001: Priority level 1  0010: Priority level 2  0011: Priority level 3  0100: Priority level 4  0101: Priority level 5  0110: Priority level 6  0111: Priority level 7  1000: Priority level 8  1001: Priority level 9  1010: Priority level 10  1011: Priority level 11  1100: Priority level 12  1101: Priority level 13  1110: Priority level 14  1111: Priority level 15 (highest)</p>
11 to 8	IPR[11:8]	0000	R/W	<p>Set priority levels for the corresponding interrupt source.</p> <p>0000: Priority level 0 (lowest)  0001: Priority level 1  0010: Priority level 2  0011: Priority level 3  0100: Priority level 4  0101: Priority level 5  0110: Priority level 6  0111: Priority level 7  1000: Priority level 8  1001: Priority level 9  1010: Priority level 10  1011: Priority level 11  1100: Priority level 12  1101: Priority level 13  1110: Priority level 14  1111: Priority level 15 (highest)</p>



Bit	Bit Name	Initial Value	R/W	Description
7 to 4	IPR[7:4]	0000	R/W	Set priority levels for the corresponding interrupt source. 0000: Priority level 0 (lowest) 0001: Priority level 1 0010: Priority level 2 0011: Priority level 3 0100: Priority level 4 0101: Priority level 5 0110: Priority level 6 0111: Priority level 7 1000: Priority level 8 1001: Priority level 9 1010: Priority level 10 1011: Priority level 11 1100: Priority level 12 1101: Priority level 13 1110: Priority level 14 1111: Priority level 15 (highest)
3 to 0	IPR[3:0]	0000	R/W	Set priority levels for the corresponding interrupt source. 0000: Priority level 0 (lowest) 0001: Priority level 1 0010: Priority level 2 0011: Priority level 3 0100: Priority level 4 0101: Priority level 5 0110: Priority level 6 0111: Priority level 7 1000: Priority level 8 1001: Priority level 9 1010: Priority level 10 1011: Priority level 11 1100: Priority level 12 1101: Priority level 13 1110: Priority level 14 1111: Priority level 15 (highest)

Note: Name in the tables above is represented by a general name. Name in the list of register is, on the other hand, represented by a module name.

## 6.4 Interrupt Sources

### 6.4.1 External Interrupts

There are four types of interrupt sources: User break, NMI, IRQ, and on-chip peripheral modules. Individual interrupts are given priority levels (0 to 16, with 0 the lowest and 16 the highest). Giving an interrupt a priority level of 0 masks it.

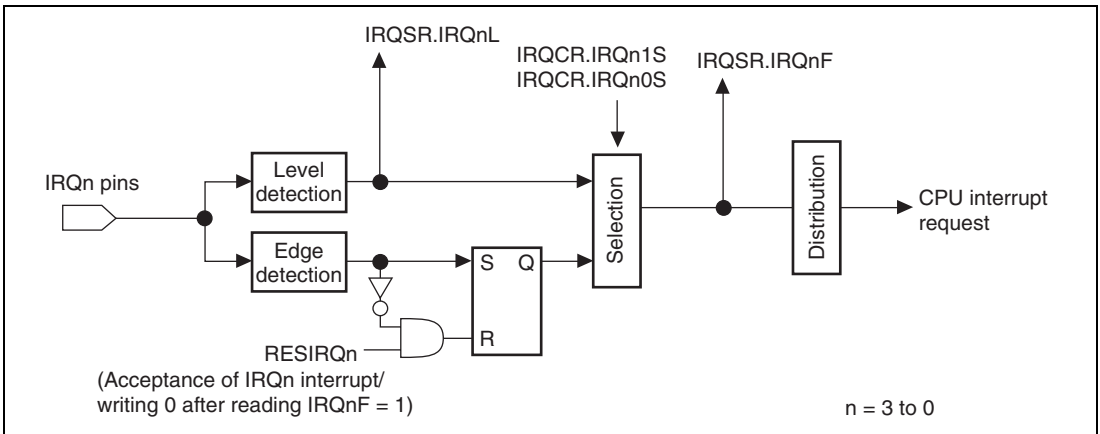
**NMI Interrupt:** The NMI interrupt is given a priority level of 16 and is always accepted. An NMI interrupt is detected at the edge of the pins. Use the NMI edge select bit (NMIE) in interrupt control register 0 (ICR0) to select either the rising or falling edge. In the NMI interrupt exception handler, the interrupt mask level bits (I3 to I0) in the status register (SR) are set to level 15.

**IRQ3 to IRQ0 Interrupts:** IRQ interrupts are requested by input from pins IRQ0 to IRQ3. Use the IRQ sense select bits (IRQ31S, IRQ30S to IRQ01S, and IRQ00S) in the IRQ control register (IRQCR) to select the detection mode from low level detection, falling edge detection, rising edge detection, and both edge detection for each pin. The priority level can be set from 0 to 15 for each pin using the interrupt priority register A (IPRA).

In the case that the low level detection is selected, an interrupt request signal is sent to the INTC while the IRQ pin is driven low. The interrupt request signal stops to be sent to the INTC when the IRQ pin becomes high. It is possible to confirm that an interrupt is requested by reading the IRQ flags (IRQ3F to IRQ0F) in the IRQ status register (IRQSR).

In the case that the edge detection is selected, an interrupt request signal is sent to the INTC when the following change on the IRQ pin is detected: from high to low in falling edge detection mode, from low to high in rising edge detection mode, and from low to high or from high to low in both edge detection mode. The IRQ interrupt request by detecting the change on the pin is held until the interrupt request is accepted. It is possible to confirm that an IRQ interrupt request has been detected by reading the IRQ flags (IRQ3F to IRQ0F) in the IRQ status register (IRQSR). An IRQ interrupt request by detecting the change on the pin can be withdrawn by writing 0 to an IRQ flag after reading 1.

In the IRQ interrupt exception handling, the interrupt mask bits (I3 to I0) in the status register (SR) are set to the priority level value of the accepted IRQ interrupt. Figure 6.2 shows the block diagram of the IRQ3 to IRQ0 interrupts.



**Figure 6.2 Block Diagram of IRQ3 to IRQ0 Interrupts Control**

### 6.4.2 On-Chip Peripheral Module Interrupts

On-chip peripheral module interrupts are interrupts generated by the following on-chip peripheral modules.

Since a different interrupt vector is allocated to each interrupt source, the exception handling routine does not have to decide which interrupt has occurred. Priority levels between 0 and 15 can be allocated to individual on-chip peripheral modules in interrupt priority registers C to F and H to M (IPRC to IPRF and IPRH to IPRM). On-chip peripheral module interrupt exception handling sets the interrupt mask level bits (I3 to I0) in the status register (SR) to the priority level value of the on-chip peripheral module interrupt that was accepted.

### 6.4.3 User Break Interrupt

A user break interrupt has a priority level of 15, and occurs when the break condition set in the user break controller (UBC) is satisfied. User break interrupt requests are detected by edge and are held until accepted. User break interrupt exception handling sets the interrupt mask level bits (I3 to I0) in the status register (SR) to level 15. For more details on the user break interrupt, see section 7, User Break Controller (UBC).

## 6.5 Interrupt Exception Handling Vector Table

Table 6.3 lists interrupt sources, their vector numbers, vector table address offsets, and interrupt priorities.

Individual interrupt sources are allocated to different vector numbers and vector table address offsets. Vector table addresses are calculated from the vector numbers and vector table address offsets. For interrupt exception handling, the start address of the exception handling routine is fetched from the vector table address in the vector table. For the details on calculation of vector table addresses, see table 5.4 in section 5, Exception Handling.

IRQ interrupts and on-chip peripheral module interrupt priorities can be set freely between 0 and 15 for each pin or module by setting interrupt priority registers A to F and H to M (IPRA to IPRF and IPRH to IPRM). However, when interrupt sources whose priority levels are allocated with the same IPR are requested, the interrupt of the smaller vector number has priority. This priority cannot be changed. Priority levels of IRQ interrupts and on-chip peripheral module interrupts are initialized to level 0 at a power-on reset. If the same priority level is allocated to two or more interrupt sources and interrupts from those sources occur simultaneously, they are processed by the default priority order shown in table 6.3.

**Table 6.3 Interrupt Exception Handling Vectors and Priorities**

Interrupt Source	Name	Vector No.	Vector Table Starting Address	IPR	Default Priority
User break		12	H'00000030	—	High
External pin	NMI	11	H'0000002C	—	↑ ↓
	IRQ0 (only SH7125)	64	H'00000100	IPRA15 to IPRA12	
	IRQ1	65	H'00000104	IPRA11 to IPRA8	
	IRQ2	66	H'00000108	IPRA7 to IPRA4	
	IRQ3	67	H'0000010C	IPRA3 to IPRA0	
MTU2_0	TGIA_0	88	H'00000160	IPRD15 to IPRD12	
	TGIB_0	89	H'00000164		
	TGIC_0	90	H'00000168		
	TGID_0	91	H'0000016C		
	TCIV_0	92	H'00000170	IPRD11 to IPRD8	
	TGIE_0	93	H'00000174		
	TGIF_0	94	H'00000178		
MTU2_1	TGIA_1	96	H'00000180	IPRD7 to IPRD4	
	TGIB_1	97	H'00000184		
	TCIV_1	100	H'00000190	IPRD3 to IPRD0	
	TCIU_1	101	H'00000194		
MTU2_2	TGIA_2	104	H'000001A0	IPRE15 to IPRE12	
	TGIB_2	105	H'000001A4		
	TCIV_2	108	H'000001B0	IPRE11 to IPRE8	
	TCIU_2	109	H'000001B4		
MTU2_3	TGIA_3	112	H'000001C0	IPRE7 to IPRE4	
	TGIB_3	113	H'000001C4		
	TGIC_3	114	H'000001C8		
	TGID_3	115	H'000001CC		
	TCIV_3	116	H'000001D0	IPRE3 to IPRE0	Low

Interrupt Source	Name	Vector No.	Vector Table Starting Address	IPR	Default Priority
MTU2_4	TGIA_4	120	H'000001E0	IPRF15 to IPRF12	High
	TGIB_4	121	H'000001E4		
	TGIC_4	122	H'000001E8		
	TGID_4	123	H'000001EC		
	TCIV_4	124	H'000001F0		
MTU2_5	TGIU_5	128	H'00000200	IPRF7 to IPRF4	
	TGIV_5	129	H'00000204		
	TGIW_5	130	H'00000208		
POE (MTU2)	OEI1	132	H'00000210	IPRF3 to IPRF0	
	OEI3	133	H'00000214		
CMT_0	CMI_0	184	H'000002E0	IPRJ15 to IPRJ12	
CMT_1	CMI_1	188	H'000002F0	IPRJ11 to IPRJ8	
WDT	ITI	196	H'00000310	IPRJ3 to IPRJ0	
A/D_0 and A/D_1	ADI_0	200	H'00000320	IPRK15 to IPRK12	
	ADI_1	201	H'00000324		
SCI_0	ERI_0	216	H'00000360	IPRL15 to IPRL12	
	RXI_0	217	H'00000364		
	TXI_0	218	H'00000368		
	TEI_0	219	H'0000036C		
SCI_1	ERI_1	220	H'00000370	IPRL11 to IPRL8	
	RXI_1	221	H'00000374		
	TXI_1	222	H'00000378		
	TEI_1	223	H'0000037C		
SCI_2	ERI_2	224	H'00000380	IPRL7 to IPRL4	
	RXI_2	225	H'00000384		
	TXI_2	226	H'00000388		
	TEI_2	227	H'0000038C		



Low

## 6.6 Interrupt Operation

### 6.6.1 Interrupt Sequence

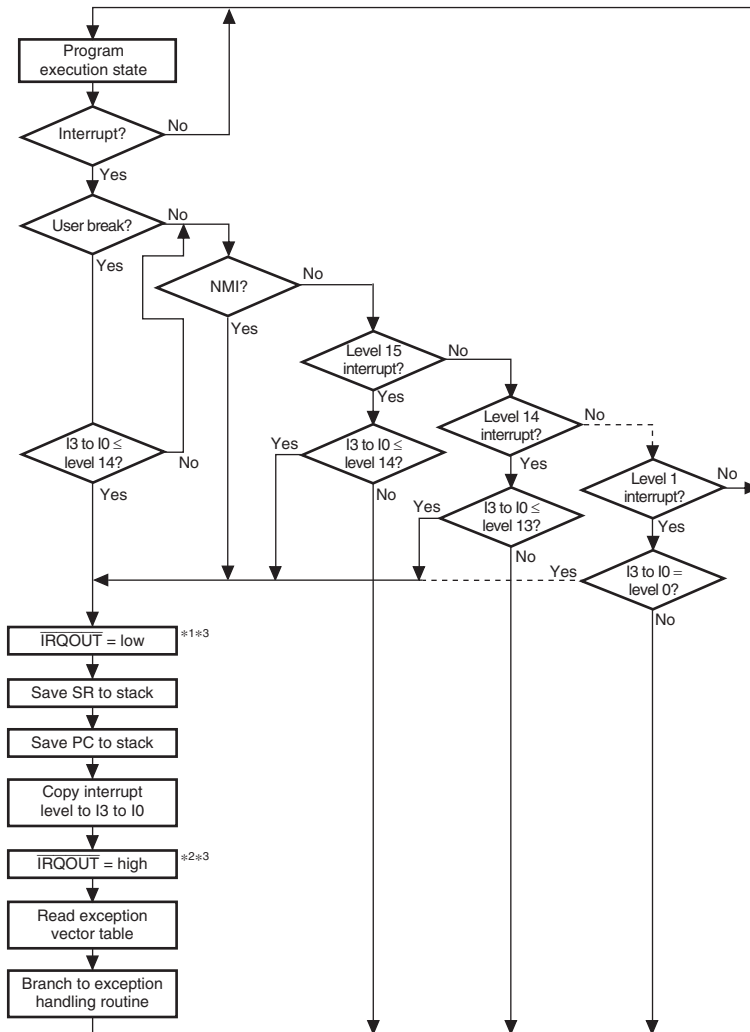
The sequence of interrupt operations is explained below. Figure 6.3 is a flowchart of the operations.

1. The interrupt request sources send interrupt request signals to the interrupt controller.
2. The interrupt controller selects the highest priority interrupt from interrupt requests sent, according to the priority levels set in interrupt priority registers A to F and H to M (IPRA to IPRF and IPRH to IPRM). Interrupts that have lower-priority than that of the selected interrupt are ignored\*. If interrupts that have the same priority level or interrupts within a same module occur simultaneously, the interrupt with the highest priority is selected according to the default priority shown in table 6.3.
3. The interrupt controller compares the priority level of the selected interrupt request with the interrupt mask bits (I3 to I0) in the status register (SR) of the CPU. If the priority level of the selected request is equal to or less than the level set in bits I3 to I0, the request is ignored. If the priority level of the selected request is higher than the level in bits I3 to I0, the interrupt controller accepts the request and sends an interrupt request signal to the CPU.
4. When the interrupt controller accepts an interrupt, a low level is output from the  $\overline{\text{IRQOUT}}$  pin.
5. The CPU detects the interrupt request sent from the interrupt controller in the decode stage of an instruction to be executed. Instead of executing the decoded instruction, the CPU starts interrupt exception handling.
6. SR and PC are saved onto the stack.
7. The priority level of the accepted interrupt is copied to bits (I3 to I0) in SR.
8. When the accepted interrupt is sensed by level or is from an on-chip peripheral module, a high level is output from the  $\overline{\text{IRQOUT}}$  pin. When the accepted interrupt is sensed by edge, a high level is output from the  $\overline{\text{IRQOUT}}$  pin at the moment when the CPU starts interrupt exception processing instead of instruction execution as noted in 5. above. However, if the interrupt controller accepts an interrupt with a higher priority than the interrupt just to be accepted, the  $\overline{\text{IRQOUT}}$  pin holds low level.
9. The CPU reads the start address of the exception handling routine from the exception vector table for the accepted interrupt, branches to that address, and starts executing the program. This branch is not a delayed branch.

Notes: The interrupt source flag should be cleared in the interrupt handler. To ensure that an interrupt source that should have been cleared is not inadvertently accepted again, read the interrupt source flag after it has been cleared, confirm that it has been cleared, and then execute an RTE instruction.

- \* Interrupt requests that are designated as edge-detect type are held pending until the interrupt requests are accepted. IRQ interrupts, however, can be cancelled by accessing the IRQ status register (IRQSR). Interrupts held pending due to edge detection are cleared by a power-on reset or a manual reset.





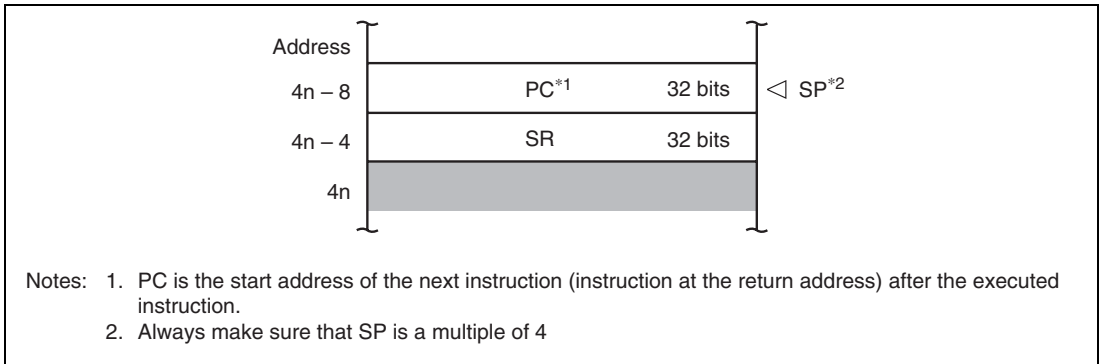
Notes: I3 to I0 are interrupt mask bits in the status register (SR) of the CPU

1.  $\overline{\text{IRQOUT}}$  is the same signal as the interrupt request signal to the CPU (see figure 6.1). Therefore,  $\overline{\text{IRQOUT}}$  is output when the request priority level is higher than the level in bits I3–I0 of SR.
2. When the accepted interrupt is sensed by edge, a high level is output from the  $\overline{\text{IRQOUT}}$  pin at the moment when the CPU starts interrupt exception processing instead of instruction execution (namely, before saving SR to stack). However, if the interrupt controller accepts an interrupt with a higher priority than the interrupt just to be accepted and has output an interrupt request to the CPU, the  $\overline{\text{IRQOUT}}$  pin holds low level.
3. The  $\overline{\text{IRQOUT}}$  pin change timing depends on a frequency dividing ratio between the internal ( $f_{\phi}$ ) and bus ( $B_{\phi}$ ) clocks. This flowchart shows that the frequency dividing ratios of the internal ( $f_{\phi}$ ) and bus ( $B_{\phi}$ ) clocks are the same.

**Figure 6.3 Interrupt Sequence Flowchart**

## 6.6.2 Stack after Interrupt Exception Handling

Figure 6.4 shows the stack after interrupt exception handling.



**Figure 6.4 Stack after Interrupt Exception Handling**

## 6.7 Interrupt Response Time

Table 6.4 lists the interrupt response time, which is the time from the occurrence of an interrupt request until the interrupt exception handling starts and fetching of the first instruction of the interrupt handling routine begins.

**Table 6.4 Interrupt Response Time**

Item	Number of Cycles			Remarks	
	NMI	IRQ	Peripheral Modules		
Interrupt priority decision and comparison with mask bits in SR	$1 \times \text{Icyc} + 2 \times \text{Pcyc}$	$1 \times \text{Icyc} + 1 \times \text{Pcyc}$	$1 \times \text{Icyc} + 2 \times \text{Pcyc}$		
Wait for completion of sequence currently being executed by CPU	$X (\geq 0)$	$X (\geq 0)$	$X (\geq 0)$	The longest sequence is for interrupt or address-error exception handling ( $X = 7 \times \text{Icyc} + m1 + m2 + m3 + m4$ ). If an interrupt-masking instruction follows, however, the time may be even longer.	
Time from start of interrupt exception handling until fetch of first instruction of exception handling routine starts	$8 \times \text{Icyc} + m1 + m2 + m3$	$8 \times \text{Icyc} + m1 + m2 + m3$	$8 \times \text{Icyc} + m1 + m2 + m3$	Performs the saving PC and SR, and vector address fetch.	
Interrupt response time	Total:	$9 \times \text{Icyc} + 2 \times \text{Pcyc} + m1 + m2 + m3 + X$	$9 \times \text{Icyc} + 1 \times \text{Pcyc} + m1 + m2 + m3 + X$	$9 \times \text{Icyc} + 2 \times \text{Pcyc} + m1 + m2 + m3 + X$	
	Minimum*:	$12 \times \text{Icyc} + 2 \times \text{Pcyc}$	$12 \times \text{Icyc} + 1 \times \text{Pcyc}$	$12 \times \text{Icyc} + 2 \times \text{Pcyc}$	SR, PC, and vector table are all in on-chip RAM.
	Maximum:	$16 \times \text{Icyc} + 2 \times \text{Pcyc} + 2 \times (m1 + m2 + m3) + m4$	$16 \times \text{Icyc} + 1 \times \text{Pcyc} + 2 \times (m1 + m2 + m3) + m4$	$16 \times \text{Icyc} + 2 \times \text{Pcyc} + 2 \times (m1 + m2 + m3) + m4$	

Notes: \* In the case that  $m1 = m2 = m3 = m4 = 1 \times \text{Icyc}$ .  
 $m1$  to  $m4$  are the number of cycles needed for the following memory accesses.  
 $m1$ : SR save (longword write)  
 $m2$ : PC save (longword write)  
 $m3$ : Vector address read (longword read)  
 $m4$ : Fetch first instruction of interrupt service routine

## 6.8 Usage Note

The interrupt source flag should be cleared in the interrupt handler. To ensure that an interrupt source that should have been cleared is not inadvertently accepted again, read the interrupt source flag after it has been cleared, confirm that it has been cleared, and then execute an RTE instruction.

## Section 7 User Break Controller (UBC)

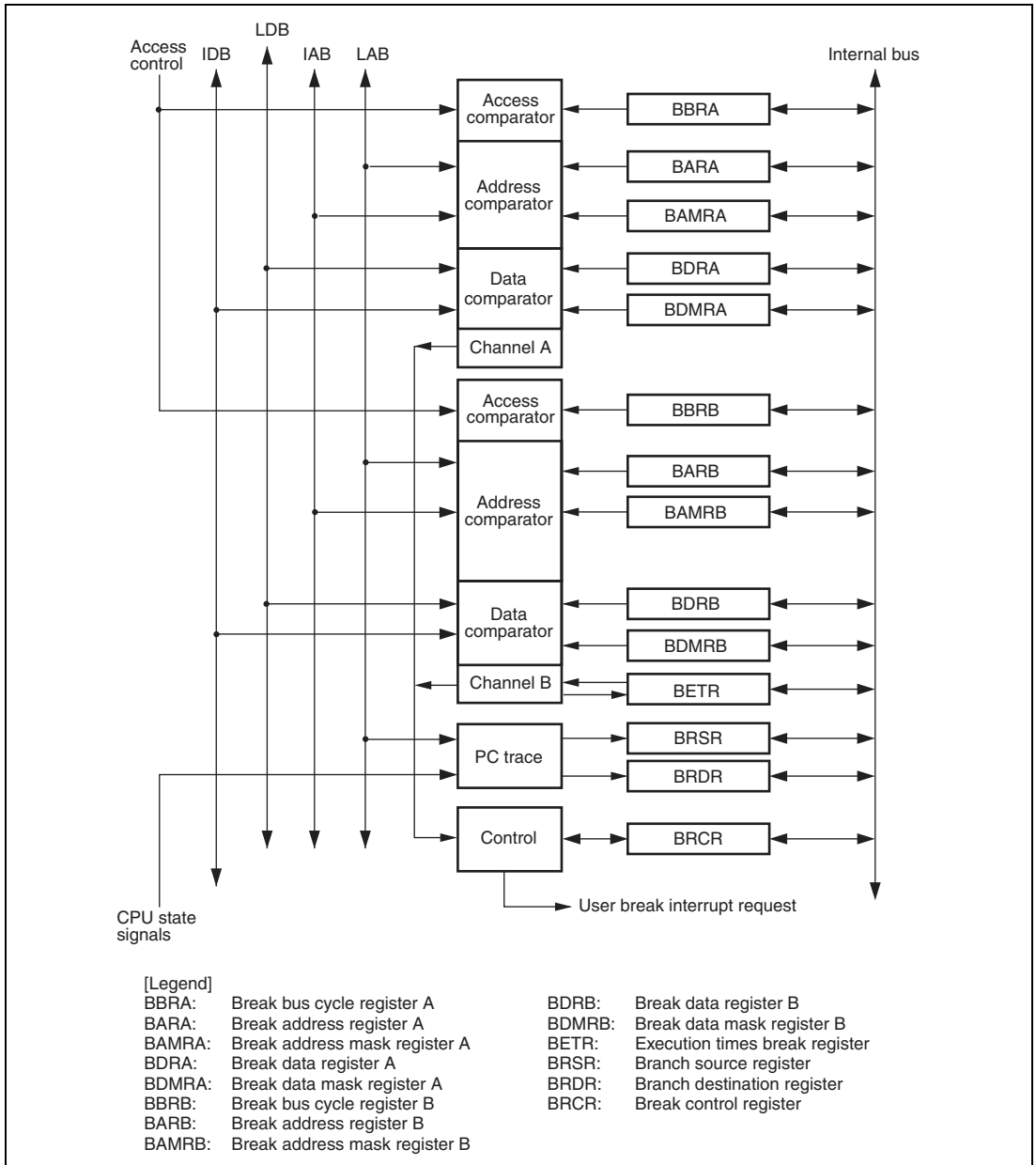
The user break controller (UBC) provides functions that simplify program debugging. These functions make it easy to design an effective self-monitoring debugger, enabling the chip to debug programs without using an in-circuit emulator. Break conditions that can be set in the UBC are instruction fetch or data read/write access, data size, data contents, address value, and stop timing in the case of instruction fetch.

### 7.1 Features

The UBC has the following features:

1. The following break comparison conditions can be set.  
Number of break channels: two channels (channels A and B)  
User break can be requested as either the independent or sequential condition on channels A and B (sequential break setting: channel A and then channel B match with break conditions, but not in the same bus cycle).
  - Address  
Comparison bits are maskable in 1-bit units.  
One of the two address buses (L-bus address (LAB) and I-bus address (IAB)) can be selected.
  - Data  
32-bit maskable.  
One of the two data buses (L-bus data (LDB) and I-bus data (IDB)) can be selected.
  - Bus cycle  
Instruction fetch or data access
  - Read/write
  - Operand size  
Byte, word, and longword
2. A user-designed user-break condition interrupt exception processing routine can be run.
3. In an instruction fetch cycle, it can be selected that a user-break is set before or after an instruction is executed.
4. Maximum repeat times for the break condition (only for channel B):  $2^{12} - 1$  times.
5. Four pairs of branch source/destination buffers.

Figure 7.1 shows a block diagram of the UBC.



**Figure 7.1 Block Diagram of UBC**

## 7.2 Register Descriptions

The user break controller has the following registers. For details on register addresses and register states during each processing, refer to section 20, List of Registers.

**Table 7.1 Register Configuration**

Register Name	Abbrevia- tion	R/W	Initial Value	Address	Access Size
Break address register A	BARA	R/W	H'00000000	H'FFFFFF300	32
Break address mask register A	BAMRA	R/W	H'00000000	H'FFFFFF304	32
Break bus cycle register A	BBRA	R/W	H'0000	H'FFFFFF308	16
Break data register A	BDRA	R/W	H'00000000	H'FFFFFF310	32
Break data mask register A	BDMRA	R/W	H'00000000	H'FFFFFF314	32
Break address register B	BARB	R/W	H'00000000	H'FFFFFF320	32
Break address mask register B	BAMRB	R/W	H'00000000	H'FFFFFF324	32
Break bus cycle register B	BBRB	R/W	H'0000	H'FFFFFF328	16
Break data register B	BDRB	R/W	H'00000000	H'FFFFFF330	32
Break data mask register B	BDMRB	R/W	H'00000000	H'FFFFFF334	32
Break control register	BRCR	R/W	H'00000000	H'FFFFFF3C0	32
Branch source register	BRSR	R	H'0xxxxxxx	H'FFFFFF3D0	32
Branch destination register	BRDR	R	H'0xxxxxxx	H'FFFFFF3D4	32
Execution times break register	BETR	R/W	H'0000	H'FFFFFF3DC	16

### 7.2.1 Break Address Register A (BARA)

BARA is a 32-bit readable/writable register. BARA specifies the address used as a break condition in channel A.

Bit:	31	30	29	28	27	26	25	24	23	22	21	20	19	18	17	16
	BAA31	BAA30	BAA29	BAA28	BAA27	BAA26	BAA25	BAA24	BAA23	BAA22	BAA21	BAA20	BAA19	BAA18	BAA17	BAA16
Initial value:	0	0	0	0	0	0	0	0	0	0	0	0	0	0	0	0
R/W:	R/W	R/W	R/W	R/W	R/W	R/W	R/W	R/W	R/W	R/W	R/W	R/W	R/W	R/W	R/W	R/W

Bit:	15	14	13	12	11	10	9	8	7	6	5	4	3	2	1	0
	BAA15	BAA14	BAA13	BAA12	BAA11	BAA10	BAA9	BAA8	BAA7	BAA6	BAA5	BAA4	BAA3	BAA2	BAA1	BAA0
Initial value:	0	0	0	0	0	0	0	0	0	0	0	0	0	0	0	0
R/W:	R/W	R/W	R/W	R/W	R/W	R/W	R/W	R/W	R/W	R/W	R/W	R/W	R/W	R/W	R/W	R/W

Bit	Bit Name	Initial Value	R/W	Description
31 to 0	BAA31 to BAA 0	All 0	R/W	Break Address A Store the address on the LAB or IAB specifying break conditions of channel A.

### 7.2.2 Break Address Mask Register A (BAMRA)

BAMRA is a 32-bit readable/writable register. BAMRA specifies bits masked in the break address specified by BARA.

Bit:	31	30	29	28	27	26	25	24	23	22	21	20	19	18	17	16
	BAMA31	BAMA30	BAMA29	BAMA28	BAMA27	BAMA26	BAMA25	BAMA24	BAMA23	BAMA22	BAMA21	BAMA20	BAMA19	BAMA18	BAMA17	BAMA16
Initial value:	0	0	0	0	0	0	0	0	0	0	0	0	0	0	0	0
R/W:	R/W	R/W	R/W	R/W	R/W	R/W	R/W	R/W	R/W	R/W	R/W	R/W	R/W	R/W	R/W	R/W

Bit:	15	14	13	12	11	10	9	8	7	6	5	4	3	2	1	0
	BAMA15	BAMA14	BAMA13	BAMA12	BAMA11	BAMA10	BAMA9	BAMA8	BAMA7	BAMA6	BAMA5	BAMA4	BAMA3	BAMA2	BAMA1	BAMA0
Initial value:	0	0	0	0	0	0	0	0	0	0	0	0	0	0	0	0
R/W:	R/W	R/W	R/W	R/W	R/W	R/W	R/W	R/W	R/W	R/W	R/W	R/W	R/W	R/W	R/W	R/W



Bit	Bit Name	Initial Value	R/W	Description
31 to 0	BAMA31 to BAMA 0	All 0	R/W	<p>Break Address Mask A</p> <p>Specify bits masked in the channel A break address bits specified by BARA (BAA31 to BAA0).</p> <p>0: Break address bit BAA<sub>n</sub> of channel A is included in the break condition</p> <p>1: Break address bit BAA<sub>n</sub> of channel A is masked and is not included in the break condition</p> <p>Note: n = 31 to 0</p>

### 7.2.3 Break Bus Cycle Register A (BBRA)

BBRA is a 16-bit readable/writable register, which specifies (1) bus master for I bus cycle, (2) L bus cycle or I bus cycle, (3) instruction fetch or data access, (4) read or write, and (5) operand size in the break conditions of channel A.

Bit:	15	14	13	12	11	10	9	8	7	6	5	4	3	2	1	0
	-	-	-	-	-	CPA[2:0]			CDA[1:0]		IDA[1:0]		RWA[1:0]		SZA[1:0]	
Initial value:	0	0	0	0	0	0	0	0	0	0	0	0	0	0	0	0
R/W:	R	R	R	R	R	R/W	R/W	R/W	R/W	R/W	R/W	R/W	R/W	R/W	R/W	R/W

Bit	Bit Name	Initial Value	R/W	Description
15 to 11	—	All 0	R	<p>Reserved</p> <p>These bits are always read as 0. The write value should always be 0.</p>
10 to 8	CPA[2:0]	000	R/W	<p>Bus Master Select A for I Bus</p> <p>Select the bus master when the I bus is selected as the bus cycle of the channel A break condition. However, when the L bus is selected as the bus cycle, the setting of the CPA2 to CPA0 bits is disabled.</p> <p>000: Condition comparison is not performed</p> <p>xx1: The CPU cycle is included in the break condition</p> <p>x1x: Setting prohibited</p> <p>1xx: Setting prohibited</p>

Bit	Bit Name	Initial Value	R/W	Description
7, 6	CDA[1:0]	00	R/W	<p>L Bus Cycle/I Bus Cycle Select A</p> <p>Select the L bus cycle or I bus cycle as the bus cycle of the channel A break condition.</p> <p>00: Condition comparison is not performed</p> <p>01: The break condition is the L bus cycle</p> <p>10: The break condition is the I bus cycle</p> <p>11: The break condition is the L bus cycle</p>
5, 4	IDA[1:0]	00	R/W	<p>Instruction Fetch/Data Access Select A</p> <p>Select the instruction fetch cycle or data access cycle as the bus cycle of the channel A break condition.</p> <p>00: Condition comparison is not performed</p> <p>01: The break condition is the instruction fetch cycle</p> <p>10: The break condition is the data access cycle</p> <p>11: The break condition is the instruction fetch cycle or data access cycle</p>
3, 2	RWA[1:0]	00	R/W	<p>Read/Write Select A</p> <p>Select the read cycle or write cycle as the bus cycle of the channel A break condition.</p> <p>00: Condition comparison is not performed</p> <p>01: The break condition is the read cycle</p> <p>10: The break condition is the write cycle</p> <p>11: The break condition is the read cycle or write cycle</p>
1, 0	SZA[1:0]	00	R/W	<p>Operand Size Select A</p> <p>Select the operand size of the bus cycle for the channel A break condition.</p> <p>00: The break condition does not include operand size</p> <p>01: The break condition is byte access</p> <p>10: The break condition is word access</p> <p>11: The break condition is longword access</p> <p>Note: When specifying the operand size, specify the size which matches the address boundary.</p>

## [Legend]

x: Don't care.

## 7.2.4 Break Data Register A (BDRA)

BDRA is a 32-bit readable/writable register. The control bits CDA1 and CDA0 in BBRA select one of two data buses for break condition A.

Bit:	31	30	29	28	27	26	25	24	23	22	21	20	19	18	17	16
	BDA31	BDA30	BDA29	BDA28	BDA27	BDA26	BDA25	BDA24	BDA23	BDA22	BDA21	BDA20	BDA19	BDA18	BDA17	BDA16
Initial value:	0	0	0	0	0	0	0	0	0	0	0	0	0	0	0	0
R/W:	R/W	R/W	R/W	R/W	R/W	R/W	R/W	R/W	R/W	R/W	R/W	R/W	R/W	R/W	R/W	R/W

Bit:	15	14	13	12	11	10	9	8	7	6	5	4	3	2	1	0
	BDA15	BDA14	BDA13	BDA12	BDA11	BDA10	BDA9	BDA8	BDA7	BDA6	BDA5	BDA4	BDA3	BDA2	BDA1	BDA0
Initial value:	0	0	0	0	0	0	0	0	0	0	0	0	0	0	0	0
R/W:	R/W	R/W	R/W	R/W	R/W	R/W	R/W	R/W	R/W	R/W	R/W	R/W	R/W	R/W	R/W	R/W

Bit	Bit Name	Initial Value	R/W	Description
31 to 0	BDA31 to BDA0	All 0	R/W	<p>Break Data Bit A</p> <p>Stores data, which specifies a break condition in channel A.</p> <p>If the I bus is selected in BBRA, the break data on IDB is set in BDA31 to BDA0.</p> <p>If the L bus is selected in BBRA, the break data on LDB is set in BDA31 to BDA0.</p>

- Notes:
1. Specify an operand size when including the value of the data bus in the break condition.
  2. When the byte size is selected as a break condition, the same byte data must be set in bits 15 to 8 and 7 to 0 in BDRA as the break data.

## 7.2.5 Break Data Mask Register A (BDMRA)

BDMRA is a 32-bit readable/writable register. BDMRA specifies bits masked in the break data specified by BDRA.

Bit:	31	30	29	28	27	26	25	24	23	22	21	20	19	18	17	16
	BDMA31	BDMA30	BDMA29	BDMA28	BDMA27	BDMA26	BDMA25	BDMA24	BDMA23	BDMA22	BDMA21	BDMA20	BDMA19	BDMA18	BDMA17	BDMA16
Initial value:	0	0	0	0	0	0	0	0	0	0	0	0	0	0	0	0
R/W:	R/W	R/W	R/W	R/W	R/W	R/W	R/W	R/W	R/W	R/W	R/W	R/W	R/W	R/W	R/W	R/W

Bit:	15	14	13	12	11	10	9	8	7	6	5	4	3	2	1	0
	BDMA15	BDMA14	BDMA13	BDMA12	BDMA11	BDMA10	BDMA9	BDMA8	BDMA7	BDMA6	BDMA5	BDMA4	BDMA3	BDMA2	BDMA1	BDMA0
Initial value:	0	0	0	0	0	0	0	0	0	0	0	0	0	0	0	0
R/W:	R/W	R/W	R/W	R/W	R/W	R/W	R/W	R/W	R/W	R/W	R/W	R/W	R/W	R/W	R/W	R/W

Bit	Bit Name	Initial Value	R/W	Description
31 to 0	BDMA31 to BDMA 0	All 0	R/W	<b>Break Data Mask A</b> Specifies bits masked in the break data of channel A specified by BDRA (BDA31 to BDA0). 0: Break data BDA <sub>n</sub> of channel A is included in the break condition 1: Break data BDA <sub>n</sub> of channel A is masked and is not included in the break condition Note: n = 31 to 0

- Notes:
- Specify an operand size when including the value of the data bus in the break condition.
  - When the byte size is selected as a break condition, the same byte data must be set in bits 15 to 8 and 7 to 0 in BDMRA as the break mask data in BDRA.

## 7.2.6 Break Address Register B (BARB)

BARB is a 32-bit readable/writable register. BARB specifies the address used as a break condition in channel B. Control bits CDB1 and CDB0 in BBRB select one of the two address buses for break condition B.

Bit:	31	30	29	28	27	26	25	24	23	22	21	20	19	18	17	16
	BAB31	BAB30	BAB29	BAB28	BAB27	BAB26	BAB25	BAB24	BAB23	BAB22	BAB21	BAB20	BAB19	BAB18	BAB17	BAB16
Initial value:	0	0	0	0	0	0	0	0	0	0	0	0	0	0	0	0
R/W:	R/W	R/W	R/W	R/W	R/W	R/W	R/W	R/W	R/W	R/W	R/W	R/W	R/W	R/W	R/W	R/W

Bit:	15	14	13	12	11	10	9	8	7	6	5	4	3	2	1	0
	BAB15	BAB14	BAB13	BAB12	BAB11	BAB10	BAB9	BAB8	BAB7	BAB6	BAB5	BAB4	BAB3	BAB2	BAB1	BAB0
Initial value:	0	0	0	0	0	0	0	0	0	0	0	0	0	0	0	0
R/W:	R/W	R/W	R/W	R/W	R/W	R/W	R/W	R/W	R/W	R/W	R/W	R/W	R/W	R/W	R/W	R/W

Bit	Bit Name	Initial Value	R/W	Description
31 to 0	BAB31 to BAB 0	All 0	R/W	<p>Break Address B</p> <p>Stores an address, which specifies a break condition in channel B.</p> <p>If the I bus or L bus is selected in BBRB, an IAB or LAB address is set in BAB31 to BAB0.</p>

### 7.2.7 Break Address Mask Register B (BAMRB)

BAMRB is a 32-bit readable/writable register. BAMRB specifies bits masked in the break address specified by BARB.

Bit:	31	30	29	28	27	26	25	24	23	22	21	20	19	18	17	16
	BAMB31	BAMB30	BAMB29	BAMB28	BAMB27	BAMB26	BAMB25	BAMB24	BAMB23	BAMB22	BAMB21	BAMB20	BAMB19	BAMB18	BAMB17	BAMB16
Initial value:	0	0	0	0	0	0	0	0	0	0	0	0	0	0	0	0
R/W:	R/W	R/W	R/W	R/W	R/W	R/W	R/W	R/W	R/W	R/W	R/W	R/W	R/W	R/W	R/W	R/W

Bit:	15	14	13	12	11	10	9	8	7	6	5	4	3	2	1	0
	BAMB15	BAMB14	BAMB13	BAMB12	BAMB11	BAMB10	BAMB9	BAMB8	BAMB7	BAMB6	BAMB5	BAMB4	BAMB3	BAMB2	BAMB1	BAMB0
Initial value:	0	0	0	0	0	0	0	0	0	0	0	0	0	0	0	0
R/W:	R/W	R/W	R/W	R/W	R/W	R/W	R/W	R/W	R/W	R/W	R/W	R/W	R/W	R/W	R/W	R/W

Bit	Bit Name	Initial Value	R/W	Description
31 to 0	BAMB31 to BAMB 0	All 0	R/W	<p>Break Address Mask B</p> <p>Specifies bits masked in the break address of channel B specified by BARB (BAB31 to BAB0).</p> <p>0: Break address BAB<sub>n</sub> of channel B is included in the break condition</p> <p>1: Break address BAB<sub>n</sub> of channel B is masked and is not included in the break condition</p> <p>Note: n = 31 to 0</p>

## 7.2.8 Break Data Register B (BDRB)

BDRB is a 32-bit readable/writable register. The control bits CDB1 and CDB0 in BBRB select one of the two data buses for break condition B.

Bit:	31	30	29	28	27	26	25	24	23	22	21	20	19	18	17	16
	BDB31	BDB30	BDB29	BDB28	BDB27	BDB26	BDB25	BDB24	BDB23	BDB22	BDB21	BDB20	BDB19	BDB18	BDB17	BDB16
Initial value:	0	0	0	0	0	0	0	0	0	0	0	0	0	0	0	0
R/W:	R/W	R/W	R/W	R/W	R/W	R/W	R/W	R/W	R/W	R/W	R/W	R/W	R/W	R/W	R/W	R/W

Bit:	15	14	13	12	11	10	9	8	7	6	5	4	3	2	1	0
	BDB15	BDB14	BDB13	BDB12	BDB11	BDB10	BDB9	BDB8	BDB7	BDB6	BDB5	BDB4	BDB3	BDB2	BDB1	BDB0
Initial value:	0	0	0	0	0	0	0	0	0	0	0	0	0	0	0	0
R/W:	R/W	R/W	R/W	R/W	R/W	R/W	R/W	R/W	R/W	R/W	R/W	R/W	R/W	R/W	R/W	R/W

Bit	Bit Name	Initial Value	R/W	Description
31 to 0	BDB31 to BDB0	All 0	R/W	<p>Break Data Bit B</p> <p>Stores data which specifies a break condition in channel B.</p> <p>If the I bus is selected in BBRB, the break data on IDB is set in BDB31 to BDB0.</p> <p>If the L bus is selected in BBRB, the break data on LDB is set in BDB31 to BDB0.</p>

- Notes:
1. Specify an operand size when including the value of the data bus in the break condition.
  2. When the byte size is selected as a break condition, the same byte data must be set in bits 15 to 8 and 7 to 0 in BDRB as the break data.

## 7.2.9 Break Data Mask Register B (BDMRB)

BDMRB is a 32-bit readable/writable register. BDMRB specifies bits masked in the break data specified by BDRB.

Bit:	31	30	29	28	27	26	25	24	23	22	21	20	19	18	17	16
	BDMB31	BDMB30	BDMB29	BDMB28	BDMB27	BDMB26	BDMB25	BDMB24	BDMB23	BDMB22	BDMB21	BDMB20	BDMB19	BDMB18	BDMB17	BDMB16
Initial value:	0	0	0	0	0	0	0	0	0	0	0	0	0	0	0	0
R/W:	R/W	R/W	R/W	R/W	R/W	R/W	R/W	R/W	R/W	R/W	R/W	R/W	R/W	R/W	R/W	R/W

Bit:	15	14	13	12	11	10	9	8	7	6	5	4	3	2	1	0
	BDMB15	BDMB14	BDMB13	BDMB12	BDMB11	BDMB10	BDMB9	BDMB8	BDMB7	BDMB6	BDMB5	BDMB4	BDMB3	BDMB2	BDMB1	BDMB0
Initial value:	0	0	0	0	0	0	0	0	0	0	0	0	0	0	0	0
R/W:	R/W	R/W	R/W	R/W	R/W	R/W	R/W	R/W	R/W	R/W	R/W	R/W	R/W	R/W	R/W	R/W

Bit	Bit Name	Initial Value	R/W	Description
31 to 0	BDMB31 to BDMB 0	All 0	R/W	<b>Break Data Mask B</b> Specifies bits masked in the break data of channel B specified by BDRB (BDB31 to BDB0). 0: Break data BDBn of channel B is included in the break condition 1: Break data BDBn of channel B is masked and is not included in the break condition Note: n = 31 to 0

- Notes:
- Specify an operand size when including the value of the data bus in the break condition.
  - When the byte size is selected as a break condition, the same byte data must be set in bits 15 to 8 and 7 to 0 in BDMRB as the break mask data in BDRB.



### 7.2.10 Break Bus Cycle Register B (BBRB)

BBRB is a 16-bit readable/writable register, which specifies (1) bus master for I bus cycle, (2) L bus cycle or I bus cycle, (3) instruction fetch or data access, (4) read or write, and (5) operand size in the break conditions of channel B.

Bit:	15	14	13	12	11	10	9	8	7	6	5	4	3	2	1	0
	-	-	-	-	-	CPB[2:0]			CDB[1:0]		IDB[1:0]		RWB[1:0]		SZB[1:0]	
Initial value:	0	0	0	0	0	0	0	0	0	0	0	0	0	0	0	0
R/W:	R	R	R	R	R	R/W	R/W	R/W	R/W	R/W	R/W	R/W	R/W	R/W	R/W	R/W

Bit	Bit Name	Initial Value	R/W	Description
15 to 11	—	All 0	R	Reserved  These bits are always read as 0. The write value should always be 0.
10 to 8	CPB[2:0]	000	R/W	Bus Master Select B for I Bus  Select the bus master when the I bus is selected as the bus cycle of the channel B break condition. However, when the L bus is selected as the bus cycle, the setting of the CPB2 to CPB0 bits is disabled.  000: Condition comparison is not performed xx1: The CPU cycle is included in the break condition x1x: Setting prohibited 1xx: Setting prohibited
7, 6	CDB[1:0]	00	R/W	L Bus Cycle/I Bus Cycle Select B  Select the L bus cycle or I bus cycle as the bus cycle of the channel B break condition.  00: Condition comparison is not performed 01: The break condition is the L bus cycle 10: The break condition is the I bus cycle 11: The break condition is the L bus cycle

Bit	Bit Name	Initial Value	R/W	Description
5, 4	IDB[1:0]	00	R/W	<p>Instruction Fetch/Data Access Select B</p> <p>Select the instruction fetch cycle or data access cycle as the bus cycle of the channel B break condition.</p> <p>00: Condition comparison is not performed</p> <p>01: The break condition is the instruction fetch cycle</p> <p>10: The break condition is the data access cycle</p> <p>11: The break condition is the instruction fetch cycle or data access cycle</p>
3, 2	RWB[1:0]	00	R/W	<p>Read/Write Select B</p> <p>Select the read cycle or write cycle as the bus cycle of the channel B break condition.</p> <p>00: Condition comparison is not performed</p> <p>01: The break condition is the read cycle</p> <p>10: The break condition is the write cycle</p> <p>11: The break condition is the read cycle or write cycle</p>
1, 0	SZB[1:0]	0	R/W	<p>Operand Size Select B</p> <p>Select the operand size of the bus cycle for the channel B break condition.</p> <p>00: The break condition does not include operand size</p> <p>01: The break condition is byte access</p> <p>10: The break condition is word access</p> <p>11: The break condition is longword access</p> <p>Note: When specifying the operand size, specify the size which matches the address boundary.</p>

## [Legend]

x: Don't care.

### 7.2.11 Break Control Register (BRCR)

BRCR sets the following conditions:

1. Channels A and B are used in two independent channel conditions or under the sequential condition.
2. A break is set before or after instruction execution.
3. Specify whether to include the number of execution times on channel B in comparison conditions.
4. Determine whether to include data bus on channels A and B in comparison conditions.
5. Enable PC trace.
6. Specify whether to request the user break interrupt when channels A and B match with comparison conditions.

BRCR is a 32-bit readable/writable register that has break conditions match flags and bits for setting a variety of break conditions.

Bit:	31	30	29	28	27	26	25	24	23	22	21	20	19	18	17	16
	-	-	-	-	-	-	-	-	-	-	-	-	UBIDB	-	UBIDA	-
Initial value:	0	0	0	0	0	0	0	0	0	0	0	0	0	0	0	0
R/W:	R	R	R	R	R	R	R	R	R	R	R	R	R/W	R	R/W	R
Bit:	15	14	13	12	11	10	9	8	7	6	5	4	3	2	1	0
	SCM FCA	SCM FCB	SCM FDA	SCM FDB	PCTE	PCBA	-	-	DBEA	PCBB	DBEB	-	SEQ	-	-	ETBE
Initial value:	0	0	0	0	0	0	0	0	0	0	0	0	0	0	0	0
R/W:	R/W	R/W	R/W	R/W	R/W	R/W	R	R	R/W	R/W	R/W	R	R/W	R	R	R/W

Bit	Bit Name	Initial Value	R/W	Description
31 to 20	—	All 0	R	Reserved These bits are always read as 0. The write value should always be 0.
19	UBIDB	0	R/W	User Break Disable B Enables or disables the user break interrupt request when the channel B break conditions are satisfied. 0: User break interrupt request is enabled when break conditions are satisfied 1: User break interrupt request is disabled when break conditions are satisfied

Bit	Bit Name	Initial Value	R/W	Description
18	—	0	R	Reserved This bit is always read as 0. The write value should always be 0.
17	UBIDA	0	R/W	User Break Disable A Enables or disables the user break interrupt request when the channel A break conditions are satisfied. 0: User break interrupt request is enabled when break conditions are satisfied 1: User break interrupt request is disabled when break conditions are satisfied
16	—	0	R	Reserved This bit is always read as 0. The write value should always be 0.
15	SCMFCA	0	R/W	L Bus Cycle Condition Match Flag A When the L bus cycle condition in the break conditions set for channel A is satisfied, this flag is set to 1. In order to clear this flag, write 0 into this bit. 0: The L bus cycle condition for channel A does not match 1: The L bus cycle condition for channel A matches
14	SCMFCB	0	R/W	L Bus Cycle Condition Match Flag B When the L bus cycle condition in the break conditions set for channel B is satisfied, this flag is set to 1. In order to clear this flag, write 0 into this bit. 0: The L bus cycle condition for channel B does not match 1: The L bus cycle condition for channel B matches
13	SCMFDA	0	R/W	I Bus Cycle Condition Match Flag A When the I bus cycle condition in the break conditions set for channel A is satisfied, this flag is set to 1. In order to clear this flag, write 0 into this bit. 0: The I bus cycle condition for channel A does not match 1: The I bus cycle condition for channel A matches

Bit	Bit Name	Initial Value	R/W	Description
12	SCMFDB	0	R/W	<p>I Bus Cycle Condition Match Flag B</p> <p>When the I bus cycle condition in the break conditions set for channel B is satisfied, this flag is set to 1. In order to clear this flag, write 0 into this bit.</p> <p>0: The I bus cycle condition for channel B does not match</p> <p>1: The I bus cycle condition for channel B matches</p>
11	PCTE	0	R/W	<p>PC Trace Enable</p> <p>0: Disables PC trace</p> <p>1: Enables PC trace</p>
10	PCBA	0	R/W	<p>PC Break Select A</p> <p>Selects the break timing of the instruction fetch cycle for channel A as before or after instruction execution.</p> <p>0: PC break of channel A is set before instruction execution</p> <p>1: PC break of channel A is set after instruction execution</p>
9, 8	—	All 0	R	<p>Reserved</p> <p>These bits are always read as 0. The write value should always be 0.</p>
7	DBEA	0	R/W	<p>Data Break Enable A</p> <p>Selects whether or not the data bus condition is included in the break condition of channel A.</p> <p>0: No data bus condition is included in the condition of channel A</p> <p>1: The data bus condition is included in the condition of channel A</p>
6	PCBB	0	R/W	<p>PC Break Select B</p> <p>Selects the break timing of the instruction fetch cycle for channel B as before or after instruction execution.</p> <p>0: PC break of channel B is set before instruction execution</p> <p>1: PC break of channel B is set after instruction execution</p>

Bit	Bit Name	Initial Value	R/W	Description
5	DBEB	0	R/W	<p>Data Break Enable B</p> <p>Selects whether or not the data bus condition is included in the break condition of channel B.</p> <p>0: No data bus condition is included in the condition of channel B</p> <p>1: The data bus condition is included in the condition of channel B</p>
4	—	0	R	<p>Reserved</p> <p>This bit is always read as 0. The write value should always be 0.</p>
3	SEQ	0	R/W	<p>Sequence Condition Select</p> <p>Selects two conditions of channels A and B as independent or sequential conditions.</p> <p>0: Channels A and B are compared under independent conditions</p> <p>1: Channels A and B are compared under sequential conditions (channel A, then channel B)</p>
2, 1	—	All 0	R	<p>Reserved</p> <p>These bits are always read as 0. The write value should always be 0.</p>
0	ETBE	0	R/W	<p>Number of Execution Times Break Enable</p> <p>Enables the execution-times break condition only on channel B. If this bit is 1 (break enable), a user break is requested when the number of break conditions matches with the number of execution times that is specified by BETR.</p> <p>0: The execution-times break condition is disabled on channel B</p> <p>1: The execution-times break condition is enabled on channel B</p>

### 7.2.12 Execution Times Break Register (BETR)

BETR is a 16-bit readable/writable register. When the execution-times break condition of channel B is enabled, this register specifies the number of execution times to make the break. The maximum number is  $2^{12} - 1$  times. When a break condition is satisfied, it decreases BETR. A user-break interrupt is requested when the break condition is satisfied after BETR becomes H'0001.

Bit:	15	14	13	12	11	10	9	8	7	6	5	4	3	2	1	0
	-	-	-	-	BET[11:0]											
Initial value:	0	0	0	0	0	0	0	0	0	0	0	0	0	0	0	0
R/W:	R	R	R	R	R/W	R/W	R/W	R/W	R/W	R/W	R/W	R/W	R/W	R/W	R/W	R/W

Bit	Bit Name	Initial Value	R/W	Description
15 to 12	—	All 0	R	Reserved These bits are always read as 0. The write value should always be 0.
11 to 0	BET[11:0]	All 0	R/W	Number of Execution Times

### 7.2.13 Branch Source Register (BRSR)

BRSR is a 32-bit read-only register. BRSR stores bits 27 to 0 in the address of the branch source instruction. BRSR has the flag bit that is set to 1 when a branch occurs. This flag bit is cleared to 0 by a power-on reset or manual reset when BRSR is read or the setting to enable PC trace is made. Other bits are not initialized by a power-on reset. The eight BRSR registers have a queue structure and a stored register is shifted at every branch.

Bit:	31	30	29	28	27	26	25	24	23	22	21	20	19	18	17	16
	SVF	-	-	-	BSA27	BSA26	BSA25	BSA24	BSA23	BSA22	BSA21	BSA20	BSA19	BSA18	BSA17	BSA16
Initial value:	0	0	0	0	-	-	-	-	-	-	-	-	-	-	-	-
R/W:	R	R	R	R	R	R	R	R	R	R	R	R	R	R	R	R
Bit:	15	14	13	12	11	10	9	8	7	6	5	4	3	2	1	0
	BSA15	BSA14	BSA13	BSA12	BSA11	BSA10	BSA9	BSA8	BSA7	BSA6	BSA5	BSA4	BSA3	BSA2	BSA1	BSA0
Initial value:	-	-	-	-	-	-	-	-	-	-	-	-	-	-	-	-
R/W:	R	R	R	R	R	R	R	R	R	R	R	R	R	R	R	R

Bit	Bit Name	Initial Value	R/W	Description
31	SVF	0	R	<p><b>BRSR Valid Flag</b></p> <p>Indicates whether the branch source address is stored. This flag bit is set to 1 when a branch occurs. This flag is cleared to 0 when BRSR is read, the setting to enable PC trace is made, or BRSR is initialized by a power-on reset.</p> <p>0: The value of BRSR register is invalid 1: The value of BRSR register is valid</p>
30 to 28	—	All 0	R	<p><b>Reserved</b></p> <p>These bits are always read as 0. The write value should always be 0.</p>
27 to 0	BSA27 to BSA0	Undefined	R	<p><b>Branch Source Address</b></p> <p>Store bits 27 to 0 of the branch source address.</p>



## 7.2.14 Branch Destination Register (BRDR)

BRDR is a 32-bit read-only register. BRDR stores bits 27 to 0 in the address of the branch destination instruction. BRDR has the flag bit that is set to 1 when a branch occurs. This flag bit is cleared to 0 by a power-on reset or manual reset when BRDR is read or the setting to enable PC trace is made. Other bits are not initialized by a power-on reset. The eight BRDR registers have a queue structure and a stored register is shifted at every branch.

Bit:	31	30	29	28	27	26	25	24	23	22	21	20	19	18	17	16
	DVF	-	-	-	BDA27	BDA26	BDA25	BDA24	BDA23	BDA22	BDA21	BDA20	BDA19	BDA18	BDA17	BDA16
Initial value:	0	0	0	0	-	-	-	-	-	-	-	-	-	-	-	-
R/W:	R	R	R	R	R	R	R	R	R	R	R	R	R	R	R	R
Bit:	15	14	13	12	11	10	9	8	7	6	5	4	3	2	1	0
	BDA15	BDA14	BDA13	BDA12	BDA11	BDA10	BDA9	BDA8	BDA7	BDA6	BDA5	BDA4	BDA3	BDA2	BDA1	BDA0
Initial value:	-	-	-	-	-	-	-	-	-	-	-	-	-	-	-	-
R/W:	R	R	R	R	R	R	R	R	R	R	R	R	R	R	R	R

Bit	Bit Name	Initial Value	R/W	Description
31	DVF	0	R	BRDR Valid Flag Indicates whether a branch destination address is stored. This flag bit is set to 1 when a branch occurs. This flag is cleared to 0 when BRDR is read, the setting to enable PC trace is made, or BRDR is initialized by a power-on reset. 0: The value of BRDR register is invalid 1: The value of BRDR register is valid
30 to 28	—	All 0	R	Reserved These bits are always read as 0. The write value should always be 0.
27 to 0	BDA27 to BDA0	Undefined	R	Branch Destination Address Store bits 27 to 0 of the branch destination address.

## 7.3 Operation

### 7.3.1 Flow of the User Break Operation

The flow from setting of break conditions to user break exception processing is described below:

1. The break addresses are set in the break address registers (BARA or BARB). The masked addresses are set in the break address mask registers (BAMRA or BAMRB). The break data is set in the break data register (BDRA or BDRB). The masked data is set in the break data mask register (BDMRA or BDMRB). The bus break conditions are set in the break bus cycle registers (BBRA or BBRB). Three groups of BBRA or BBRB (L bus cycle/I bus cycle select, instruction fetch/data access select, and read/write select) are each set. No user break will be generated if even one of these groups is set with B'00. The respective conditions are set in the bits of the break control register (BRCR). Make sure to set all registers related to breaks before setting BBRA or BBRB.
2. When the break conditions are satisfied, the UBC sends a user break interrupt request to the CPU and sets the L bus condition match flag (SCMFCA or SCMFCE) and the I bus condition match flag (SCMFDA or SCMFDE) for the appropriate channel.
3. The appropriate condition match flags (SCMFCA, SCMFCE, SCMFDA, and SCMFDE) can be used to check if the set conditions match or not. The matching of the conditions sets flags, but they are not reset. Before using them again, 0 must first be written to them and then reset flags.
4. There may be an occasion when a break condition match occurs both in channels A and B around the same time. In this case, the flags for both conditions matches will be set even though only one user-break interrupt request is issued to the CPU.
5. When selecting the I bus as the break condition, note the following:
  - The CPU is connected to the I bus. The UBC monitors bus cycles generated by all bus masters that are selected by the CPA2 to CPA0 bits in BBRA or the CPB2 to CPB0 bits in BBRB, and compares the condition match.
  - I bus cycles (including read fill cycles) resulting from instruction fetches on the L bus by the CPU are defined as instruction fetch cycles on the I bus, while other bus cycles are defined as data access cycles.
  - If a break condition is specified for the I bus, even when the condition matches in an I bus cycle resulting from an instruction executed by the CPU, at which instruction the user-break is to be accepted cannot be clearly defined.

### 7.3.2 Break on Instruction Fetch Cycle

1. When L bus/instruction fetch/read/word, longword, or not including the operand size is set in the break bus cycle register (BBRA or BBRB), the break condition becomes the L bus instruction fetch cycle. Whether it breaks before or after the execution of the instruction can then be selected with the PCBA or PCBB bit in the break control register (BRCR) for the appropriate channel. If an instruction fetch cycle is set as a break condition, clear LSB in the break address register (BARA or BARB) to 0. A break cannot be generated as long as this bit is set to 1.
2. An instruction set for a break before execution breaks when it is confirmed that the instruction has been fetched and will be executed. This means this feature cannot be used on instructions fetched by overrun (instructions fetched at a branch or during an interrupt transition, but not to be executed). When this kind of break is set for the delay slot of a delayed branch instruction, the break is generated prior to execution of the delayed branch instruction.

Note: If a branch does not occur at a delay condition branch instruction, the subsequent instruction is not recognized as a delay slot.

3. When the condition is specified to be occur after execution, the instruction set with the break condition is executed and then the break is generated prior to the execution of the next instruction. As with pre-execution breaks, this cannot be used with overrun fetch instructions. When this kind of break is set for a delayed branch instruction and its delay slot, a break is not generated until the first instruction at the branch destination.
4. When an instruction fetch cycle is set, the break data register (BDRA or BDRB) is ignored. Therefore, break data cannot be set for the break of the instruction fetch cycle.
5. If the I bus is set for a break of an instruction fetch cycle, the condition is determined for the instruction fetch cycles on the I bus. For details, see 5 in section 7.3.1, Flow of the User Break Operation.

### 7.3.3 Break on Data Access Cycle

1. If the L bus is specified as a break condition for data access break, condition comparison is performed for the address (and data) accessed by the executed instructions, and a break occurs if the condition is satisfied. If the I bus is specified as a break condition, condition comparison is performed for the addresses (and data) of the data access cycles that are issued on the I bus by all bus masters including the CPU, and a break occurs if the condition is satisfied. For details on the CPU bus cycles issued on the I bus, see 5 in section 7.3.1, Flow of the User Break Operation.
2. The relationship between the data access cycle address and the comparison condition for each operand size is listed in table 7.2.

**Table 7.2 Data Access Cycle Addresses and Operand Size Comparison Conditions**

<b>Access Size</b>	<b>Address Compared</b>
Longword	Compares break address register bits 31 to 2 to address bus bits 31 to 2
Word	Compares break address register bits 31 to 1 to address bus bits 31 to 1
Byte	Compares break address register bits 31 to 0 to address bus bits 31 to 0

This means that when address H'00001003 is set in the break address register (BARA or BARB), for example, the bus cycle in which the break condition is satisfied is as follows (where other conditions are met).

Longword access at H'00001000

Word access at H'00001002

Byte access at H'00001003

3. When the data value is included in the break conditions:

When the data value is included in the break conditions, either longword, word, or byte is specified as the operand size of the break bus cycle register (BBRA or BBRB). When data values are included in break conditions, a break is generated when the address conditions and data conditions both match. To specify byte data for this case, set the same data in two bytes at bits 15 to 8 and bits 7 to 0 of the break data register (BDRA or BDRB) and break data mask register (BDMRA or BDMRB). When word or byte is set, bits 31 to 16 of BDRA or BDRB and BDMRA or BDMRB are ignored.

4. If the L bus is selected, a break occurs on ending execution of the instruction that matches the break condition, and immediately before the next instruction is executed. However, when data is also specified as the break condition, the break may occur on ending execution of the instruction following the instruction that matches the break condition. If the I bus is selected, the instruction at which the break will occur cannot be determined. When this kind of break occurs at a delayed branch instruction or its delay slot, the break may not actually take place until the first instruction at the branch destination.

### 7.3.4 Sequential Break

1. By setting the SEQ bit in BRCCR to 1, the sequential break is issued when a channel B break condition matches after a channel A break condition matches. A user break is not generated even if a channel B break condition matches before a channel A break condition matches. When channels A and B conditions match at the same time, the sequential break is not issued. To clear the channel A condition match when a channel A condition match has occurred but a channel B condition match has not yet occurred in a sequential break specification, clear the SEQ bit in BRCCR to 0 and clear also the condition match flag to 0 in channel A.
2. In sequential break specification, the L or I bus can be selected and the execution times break condition can be also specified. For example, when the execution times break condition is specified, the break condition is satisfied when a channel B condition matches with BETR = H'0001 after a channel A condition has matched.

### 7.3.5 Value of Saved Program Counter

When a break occurs, the address of the instruction from where execution is to be resumed is saved in the stack, and the exception handling state is entered. If the L bus is specified as a break condition, the instruction at which the break should occur can be clearly determined (except for when data is included in the break condition). If the I bus is specified as a break condition, the instruction at which the break should occur cannot be clearly determined.

1. When instruction fetch (before instruction execution) is specified as a break condition:  
The address of the instruction that matched the break condition is saved in the stack. The instruction that matched the condition is not executed, and the break occurs before it. However when a delay slot instruction matches the condition, the address of the delayed branch instruction is saved in the stack.
2. When instruction fetch (after instruction execution) is specified as a break condition:  
The address of the instruction following the instruction that matched the break condition is saved in the stack. The instruction that matches the condition is executed, and the break occurs before the next instruction is executed. However, when a delayed branch instruction or delay slot matches the condition, these instructions are executed, and the branch destination address is saved in the stack.
3. When data access (address only) is specified as a break condition:  
The address of the instruction immediately after the instruction that matched the break condition is saved in the stack. The instruction that matches the condition is executed, and the break occurs before the next instruction is executed. However when a delay slot instruction matches the condition, the branch destination address is saved in the stack.

4. When data access (address + data) is specified as a break condition:

When a data value is added to the break conditions, the address of an instruction that is within two instructions of the instruction that matched the break condition is saved in the stack. At which instruction the break occurs cannot be determined accurately.

When a delay slot instruction matches the condition, the branch destination address is saved in the stack. If the instruction following the instruction that matches the break condition is a branch instruction, the break may occur after the branch instruction or delay slot has finished. In this case, the branch destination address is saved in the stack.

### 7.3.6 PC Trace

1. Setting PCTE in BRCCR to 1 enables PC traces. When branch (branch instruction, and interrupt exception) is generated, the branch source address and branch destination address are stored in BRSR and BRDR, respectively.
2. The values stored in BRSR and BRDR are as given below due to the kind of branch.
  - If a branch occurs due to a branch instruction, the address of the branch instruction is saved in BRSR and the address of the branch destination instruction is saved in BRDR.
  - If a branch occurs due to an interrupt or exception, the value saved in stack due to exception occurrence is saved in BRSR and the start address of the exception handling routine is saved in BRDR.
3. BRSR and BRDR have four pairs of queue structures. The top of queues is read first when the address stored in the PC trace register is read. BRSR and BRDR share the read pointer. Read BRSR and BRDR in order, the queue only shifts after BRDR is read. After switching the PCTE bit (in BRCCR) off and on, the values in the queues are invalid.

### 7.3.7 Usage Examples

#### Break Condition Specified for L Bus Instruction Fetch Cycle:

(Example 1-1)

- Register specifications

BARA = H'00000404, BAMRA = H'00000000, BBRA = H'0054, BDRA = H'00000000,  
BDMRA = H'00000000, BARB = H'00008010, BAMRB = H'00000006, BBRB = H'0054,  
BDRB = H'00000000, BDMRB = H'00000000, BR CR = H'00000400

Specified conditions: Channel A/channel B independent mode

<Channel A>

Address: H'00000404, Address mask: H'00000000

Data: H'00000000, Data mask: H'00000000

Bus cycle: L bus/instruction fetch (after instruction execution)/read (operand size is not included in the condition)

<Channel B>

Address: H'00008010, Address mask: H'00000006

Data: H'00000000, Data mask: H'00000000

Bus cycle: L bus/instruction fetch (before instruction execution)/read (operand size is not included in the condition)

A user break occurs after an instruction of address H'00000404 is executed or before instructions of addresses H'00008010 to H'00008016 are executed.

(Example 1-2)

- Register specifications

BARA = H'00037226, BAMRA = H'00000000, BBRA = H'0056, BDRA = H'00000000,  
BDMRA = H'00000000, BARB = H'0003722E, BAMRB = H'00000000, BBRB = H'0056,  
BDRB = H'00000000, BDMRB = H'00000000, BR CR = H'00000008

Specified conditions: Channel A/channel B sequential mode

<Channel A>

Address: H'00037226, Address mask: H'00000000

Data: H'00000000, Data mask: H'00000000

Bus cycle: L bus/instruction fetch (before instruction execution)/read/word

## &lt;Channel B&gt;

Address: H'0003722E, Address mask: H'00000000

Data: H'00000000, Data mask: H'00000000

Bus cycle: L bus/instruction fetch (before instruction execution)/read/word

After an instruction with address H'00037226 is executed, a user break occurs before an instruction with address H'0003722E is executed.

## (Example 1-3)

- Register specifications

BARA = H'00027128, BAMRA = H'00000000, BBRA = H'005A, BDRA = H'00000000,  
BDMRA = H'00000000, BARB = H'00031415, BAMRB = H'00000000, BBRB = H'0054,  
BDRB = H'00000000, BDMRB = H'00000000, BR CR = H'00000000

Specified conditions: Channel A/channel B independent mode

## &lt;Channel A&gt;

Address: H'00027128, Address mask: H'00000000

Data: H'00000000, Data mask: H'00000000

Bus cycle: L bus/instruction fetch (before instruction execution)/write/word

## &lt;Channel B&gt;

Address: H'00031415, Address mask: H'00000000

Data: H'00000000, Data mask: H'00000000

Bus cycle: L bus/instruction fetch (before instruction execution)/read (operand size is not included in the condition)

On channel A, no user break occurs since instruction fetch is not a write cycle. On channel B, no user break occurs since instruction fetch is performed for an even address.

## (Example 1-4)

- Register specifications

BARA = H'00037226, BAMRA = H'00000000, BBRA = H'005A, BDRA = H'00000000,  
BDMRA = H'00000000, BARB = H'0003722E, BAMRB = H'00000000, BBRB = H'0056,  
BDRB = H'00000000, BDMRB = H'00000000, BR CR = H'00000000

Specified conditions: Channel A/channel B sequential mode

## &lt;Channel A&gt;

Address: H'00037226, Address mask: H'00000000

Data: H'00000000, Data mask: H'00000000

Bus cycle: L bus/instruction fetch (before instruction execution)/write/word



<Channel B>

Address: H'0003722E, Address mask: H'00000000

Data: H'00000000, Data mask: H'00000000

Bus cycle: L bus/instruction fetch (before instruction execution)/read/word

Since instruction fetch is not a write cycle on channel A, a sequential condition does not match. Therefore, no user break occurs.

(Example 1-5)

- Register specifications

BARA = H'00000500, BAMRA = H'00000000, BBRA = H'0057, BDRA = H'00000000,  
BDMRA = H'00000000, BARB = H'00001000, BAMRB = H'00000000, BBRB = H'0057,  
BDRB = H'00000000, BDMRB = H'00000000, BR CR = H'00000001, BETR = H'0005

Specified conditions: Channel A/channel B independent mode

<Channel A>

Address: H'00000500, Address mask: H'00000000

Data: H'00000000, Data mask: H'00000000

Bus cycle: L bus/instruction fetch (before instruction execution)/read/longword

The number of execution-times break enable (5 times)

<Channel B>

Address: H'00001000, Address mask: H'00000000

Data: H'00000000, Data mask: H'00000000

Bus cycle: L bus/instruction fetch (before instruction execution)/read/longword

On channel A, a user break occurs after the instruction of address H'00000500 is executed four times and before the fifth time.

On channel B, a user break occurs before an instruction of address H'00001000 is executed.

(Example 1-6)

- Register specifications

BARA = H'00008404, BAMRA = H'00000FFF, BBRA = H'0054, BDRA = H'00000000,  
BDMRA = H'00000000, BARB = H'00008010, BAMRB = H'00000006, BBRB = H'0054,  
BDRB = H'00000000, BDMRB = H'00000000, BR CR = H'00000400

Specified conditions: Channel A/channel B independent mode

<Channel A>

Address: H'00008404, Address mask: H'00000FFF

Data: H'00000000, Data mask: H'00000000

Bus cycle: L bus/instruction fetch (after instruction execution)/read (operand size is not included in the condition)

<Channel B>

Address: H'00008010, Address mask: H'00000006

Data: H'00000000, Data mask: H'00000000

Bus cycle: L bus/instruction fetch (before instruction execution)/read (operand size is not included in the condition)

A user break occurs after an instruction with addresses H'00008000 to H'00008FFE is executed or before an instruction with addresses H'00008010 to H'00008016 are executed.

### Break Condition Specified for L Bus Data Access Cycle:

(Example 2-1)

- Register specifications

BARA = H'00123456, BAMRA = H'00000000, BBRA = H'0064, BDRA = H'12345678, BDMRA = H'FFFFFFFF, BARB = H'000ABCDE, BAMRB = H'000000FF, BBRB = H'006A, BDRB = H'0000A512, BDMRB = H'00000000, BRBR = H'00000080

Specified conditions: Channel A/channel B independent mode

<Channel A>

Address: H'00123456, Address mask: H'00000000

Data: H'12345678, Data mask: H'FFFFFFFF

Bus cycle: L bus/data access/read (operand size is not included in the condition)

<Channel B>

Address: H'000ABCDE, Address mask: H'000000FF

Data: H'0000A512, Data mask: H'00000000

Bus cycle: L bus/data access/write/word

On channel A, a user break occurs with longword read from address H'00123454, word read from address H'00123456, or byte read from address H'00123456. On channel B, a user break occurs when word H'A512 is written in addresses H'000ABC00 to H'000ABCFE.

**Break Condition Specified for I Bus Data Access Cycle:**

(Example 3-1)

- Register specifications

BARA = H'00314154, BAMRA = H'00000000, BBRA = H'0194, BDRA = H'12345678,  
 BDMRA = H'FFFFFFFF, BARB = H'00055555, BAMRB = H'00000000, BBRB = H'01A9,  
 BDRB = H'00007878, BDMRB = H'0000F0F, BR CR = H'00000080

Specified conditions: Channel A/channel B independent mode

<Channel A>

Address: H'00314154, Address mask: H'00000000

Data: H'12345678, Data mask: H'FFFFFFFF

Bus cycle: I bus (CPU cycle)/instruction fetch/read (operand size is not included in the condition)

<Channel B>

Address: H'00055555, Address mask: H'00000000

Data: H'00000078, Data mask: H'0000000F

Bus cycle: I bus (CPU cycle)/data access/write/byte

On channel A, a user break occurs when instruction fetch is performed for address H'00314154 in the external memory space.

On channel B, a user break occurs when byte data H'7x is written in address H'00055555 in the external memory space by the CPU.

## 7.4 Usage Notes

1. The CPU can read from or write to the UBC registers via the I bus. Accordingly, during the period from executing an instruction to rewrite the UBC register till the new value is actually rewritten, the desired break may not occur. In order to know the timing when the UBC register is changed, read from the last written register. Instructions after then are valid for the newly written register value.
2. UBC cannot monitor access to the L bus and I bus in the same channel.
3. Note on specification of sequential break:

A condition match occurs when a B-channel match occurs in a bus cycle after an A-channel match occurs in another bus cycle in sequential break setting. Therefore, no break occurs even if a bus cycle, in which an A-channel match and a channel B match occur simultaneously, is set.
4. When a user break and another exception occur at the same instruction, which has higher priority is determined according to the priority levels defined in table 5.1 in section 5, Exception Handling. If an exception with higher priority occurs, the user break is not generated.
  - Pre-execution break has the highest priority.
  - When a post-execution break or data access break occurs simultaneously with a re-execution-type exception (including pre-execution break) that has higher priority, the re-execution-type exception is accepted, and the condition match flag is not set (see the exception in the following note). The break will occur and the condition match flag will be set only after the exception source of the re-execution-type exception has been cleared by the exception handling routine and re-execution of the same instruction has ended.
  - When a post-execution break or data access break occurs simultaneously with a completion-type exception (TRAPA) that has higher priority, though a break does not occur, the condition match flag is set.
5. Note the following exception for the above note.

If a post-execution break or data access break is satisfied by an instruction that generates a CPU address error by data access, the CPU address error is given priority to the break. Note that the UBC condition match flag is set in this case.
6. Note the following when a break occurs in a delay slot.

If a pre-execution break is set at the delay slot instruction of the RTE instruction, the break does not occur until the branch destination of the RTE instruction.
7. User breaks are disabled during UBC module standby mode. Do not read from or write to the UBC registers during UBC module standby mode; the values are not guaranteed.

8. Do not set a post-execution break at a SLEEP instruction or a branch instruction for which a SLEEP instruction is placed in the delay slot. In addition, do not set a data access break at a SLEEP instruction or one or two instructions before a SLEEP instruction.



## Section 8 Bus State Controller (BSC)

The bus state controller (BSC) controls data transmission and reception between the internal buses (L bus, I bus, and peripheral bus) and also controls the CPU's access to the on-chip FLASH, on-chip RAM, and on-chip peripheral I/O.

### 8.1 Features

- On-chip FLASH and RAM interface
  - 32-bit data access per one clock cycle ( $I\phi$  synchronous)

### 8.2 Address Map

The address map is listed in table 8.1.

**Table 8.1 Address Map**

Address	Type of Memory	Size			Bus Width
		128 Kbytes Version	64 Kbytes Version	32 Kbytes Version	
H'00000000 to H'00007FFF	On-chip FLASH	128 Kbytes	64 Kbytes	32 Kbytes	32
H'00008000 to H'0000FFFF				Reserved	
H'00010000 to H'0001FFFF			Reserved		
H'00020000 to H'FFFF9FFF	Reserved	—	—	—	—
H'FFFA000 to H'FFFBFFF	On-chip RAM	8 Kbytes	8 Kbytes	8 Kbytes	32
H'FFFC000 to H'FFFFFFF	On-chip peripheral I/O	128 Kbytes	64 Kbytes	64 Kbytes	8/16

### 8.3 Access to on-chip FLASH and on-chip RAM

Access to the on-chip FLASH for read is synchronized with  $I\phi$  clock and is executed in one clock cycle. For details on programming and erasing, see section 17, Flash Memory.

Access to the on-chip RAM for read/write is synchronized with  $I\phi$  clock and is executed in one clock cycle. For details, see section 18, RAM.

## 8.4 Access to on-chip Peripheral I/O Register

The on-chip peripheral I/O register is accessed by the bus state controller (BSC) as described in table 8.2.

**Table 8.2 Connection Bus Width of on-chip Peripheral Module and the Number of Access Cycles**

On-chip Peripheral Module	INTC	UBC	MTU2	POE2	WDT	SCI	ADC	CMT	PFC, Port	
Connection Bus Width	16	16	16	16	16	8	16	16	16	
Number of Access Cycles	Write	$(3 + n) \times \text{Iclk} + (1 + m) \times \text{Bclk} + 2 \times \text{Pclk}$								
	Read	$(3 + n) \times \text{Iclk} + (1 + m) \times \text{Bclk} + 2 \times \text{Pclk} + 2 \times \text{Iclk}$								

Note: When  $m = 0$  to  $3$ ,  $\text{Bclk}:\text{Pclk} = 4:1$

When  $n = 0$  to  $3$ ,  $\text{Iclk}:\text{Bclk} = 4:1$

When  $m = 0, 1$ ,  $\text{Bclk}:\text{Pclk} = 2:1$

When  $n = 0, 1$ ,  $\text{Iclk}:\text{Bclk} = 2:1$

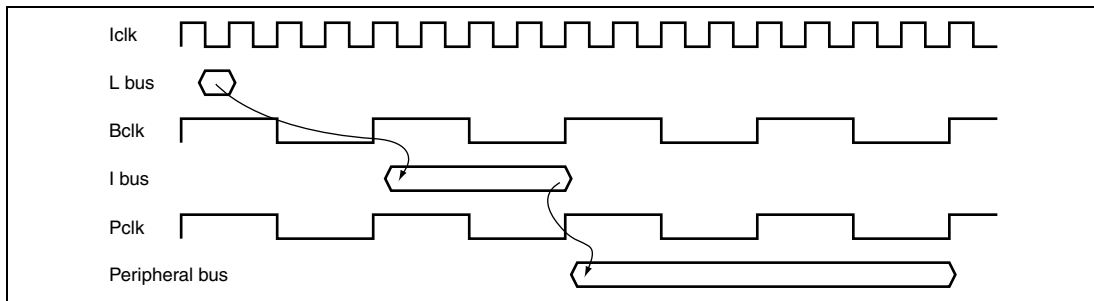
When  $m = 0$ ,  $\text{Bclk}:\text{Pclk} = 1:1$

When  $n = 0$ ,  $\text{Iclk}:\text{Bclk} = 1:1$

This LSI adopts synchronous logic, and data of each bus is input and output in synchronization with the rising edge of the corresponding clock. The L bus access takes one Iclk cycle, I bus access takes one Bclk cycle, and peripheral bus access takes two Pclk cycles. When the on-chip peripheral I/O register is accessed by the CPU, the period required for preparation for data transfer to the I bus is a period of 3 Iclk cycles.

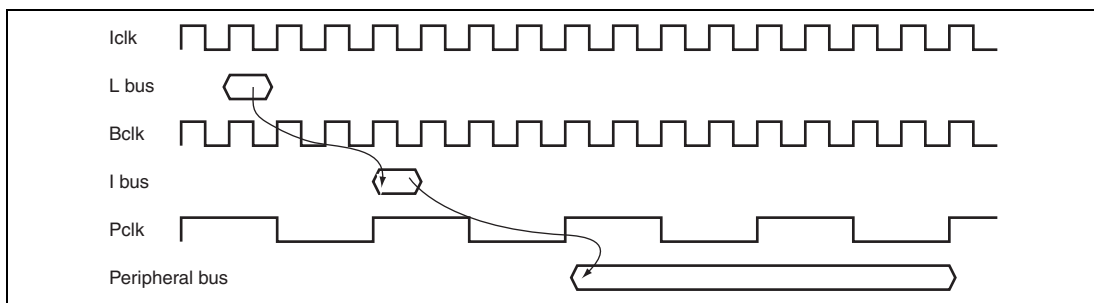
Figure 8.1 shows an example of timing of write access to the peripheral bus when  $\text{Iclk}:\text{Bclk}:\text{Pclk} = 4:1:1$ . From the L bus, to which the CPU is connected, data is output in synchronization with Iclk. Since there are four Iclk cycles in a single Bclk cycle when  $\text{Iclk}:\text{Bclk} = 4:1$ , data can be output onto the L bus in four possible timings within one Bclk cycle. Accordingly, a maximum of four Iclk cycles of period (four Iclk cycles in the example shown in the figure) is required before the rising edge of Bclk, on which data is transferred from the L bus to the I bus. Because of this, data is transferred from the L bus to the I bus in a period of  $(3 + n) \times \text{Iclk}$  ( $n = 0$  to  $3$ ) when  $\text{Iclk}:\text{Bclk} = 4:1$ . The relation of the timing of data output to the L bus and the rising edge of Bclk depends on the state of program execution. In the case shown in figure 8.1, where  $\text{Bclk} = \text{Pclk} = 1:1$ , the period required for access by the CPU is  $(3 + n) \times \text{Iclk} + 1 \times \text{Bclk} + 2 \times \text{Pclk}$ .





**Figure 8.1 Timing of Write Access to the Peripheral Bus (Iclk:Bclk:Pclk = 4:1:1)**

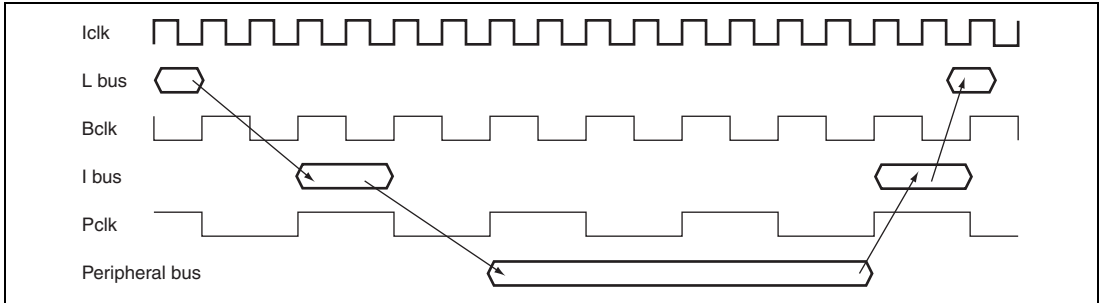
Figure 8.2 shows an example of timing of write access to the peripheral bus when Iclk:Bclk:Pclk = 4:4:1. From the L bus, to which the CPU is connected, data is output in synchronization with Iclk. When Iclk:Bclk = 1:1, a period of 3 Iclk + Bclk is required to transfer data from the L bus to the I bus. In data transfer from the I bus to the peripheral bus, there are four BIclk cycles in a single Pclk cycle when Bclk:Pclk = 4:1, and data can therefore be output onto the peripheral bus in four possible timings within one Pclk cycle. Accordingly, a maximum of four Bclk cycles of period (four Bclk cycles in the example shown in the figure) is required before the rising edge of Pclk, on which data is transferred from the I bus to the peripheral bus. Because of this, data is transferred from the I bus to the peripheral bus in a period of  $(1 + m) \times \text{Bclk}$  ( $m = 0$  to 3) when Bclk:Pclk = 4:1. The relation of the timing of data output to the I bus and the rising edge of Pclk depends on the state of program execution. In the case shown in figure 8.2, where Iclk = Bclk = 1:1, the period required for access by the CPU is  $3 \times \text{Iclk} + (1 + m) \times \text{Bclk} + 2 \times \text{Pclk}$ .



**Figure 8.2 Timing of Write Access to the Peripheral Bus (Iclk:Bclk:Pclk = 4:4:1)**

Figure 8.3 shows an example of timing of read access to the peripheral bus when Iclk:Bclk:Pclk = 4:2:1. Transfer from the L bus to the peripheral bus is performed in the same way as for write access. In the case of reading, however, values output onto the peripheral bus must be transferred to the CPU. Transfers from the external bus to the I bus and from the I bus to the L bus are again performed in synchronization with rising edges of the respective bus clocks.  $2 \times \text{Iclk}$  cycles of

period is required because  $Iclk \geq Bclk \geq Pclk$ . In the case shown in figure 8.3, where  $n = 0$  and  $m = 1$ , the period required for access by the CPU is  $3 \times Iclk + 2 \times Bclk + 2 \times Pclk + 2 \times Iclk$ .



**Figure 8.3 Timing of Read Access to the Peripheral Bus (Iclk:Bclk:Pclk = 4:2:1)**

## Section 9 Multi-Function Timer Pulse Unit 2 (MTU2)

This LSI has an on-chip multi-function timer pulse unit 2 (MTU2) that comprises six 16-bit timer channels.

### 9.1 Features

- Maximum 16 (SH7125) or 12 (SH7124) pulse input/output lines and three pulse input lines
- Selection of eight counter input clocks for each channel (four clocks for channel 5)
- The following operations can be set for channels 0 to 4:
  - Waveform output at compare match
  - Input capture function
  - Counter clear operation
  - Multiple timer counters (TCNT) can be written to simultaneously
  - Simultaneous clearing by compare match and input capture is possible
  - Register simultaneous input/output is possible by synchronous counter operation
  - A maximum 12-phase PWM output is possible in combination with synchronous operation
- Buffer operation settable for channels 0, 3, and 4
- Phase counting mode settable independently for each of channels 1 and 2
- Cascade connection operation
- Fast access via internal 16-bit bus
- 28 interrupt sources
- Automatic transfer of register data
- A/D converter start trigger can be generated
- Module standby mode can be settable
- A total of six-phase waveform output, which includes complementary PWM output, and positive and negative phases of reset PWM output by interlocking operation of channels 3 and 4, is possible.
- AC synchronous motor (brushless DC motor) drive mode using complementary PWM output and reset PWM output is settable by interlocking operation of channels 0, 3, and 4, and the selection of two types of waveform outputs (chopping and level) is possible.
- Dead time compensation counter available in channel 5
- In complementary PWM mode, interrupts at the crest and trough of the counter value and A/D converter start triggers can be skipped.

**Table 9.1 MTU2 Functions**

Item	Channel 0	Channel 1	Channel 2	Channel 3	Channel 4	Channel 5
Count clock	MP $\phi$ /1	MP $\phi$ /1	MP $\phi$ /1	MP $\phi$ /1	MP $\phi$ /1	MP $\phi$ /1
	MP $\phi$ /4	MP $\phi$ /4	MP $\phi$ /4	MP $\phi$ /4	MP $\phi$ /4	MP $\phi$ /4
	MP $\phi$ /16	MP $\phi$ /16	MP $\phi$ /16	MP $\phi$ /16	MP $\phi$ /16	MP $\phi$ /16
	MP $\phi$ /64	MP $\phi$ /64	MP $\phi$ /64	MP $\phi$ /64	MP $\phi$ /64	MP $\phi$ /64
	TCLKA	MP $\phi$ /256	MP $\phi$ /1024	MP $\phi$ /256	MP $\phi$ /256	
	TCLKB	TCLKA	TCLKA	MP $\phi$ /1024	MP $\phi$ /1024	
	TCLKC	TCLKB	TCLKB	TCLKA	TCLKA	
	TCLKD		TCLKC	TCLKB	TCLKB	
General registers	TGRA_0	TGRA_1	TGRA_2	TGRA_3	TGRA_4	TGRU_5
	TGRB_0	TGRB_1	TGRB_2	TGRB_3	TGRB_4	TGRV_5
	TGRE_0					TGRW_5
General registers/ buffer registers	TGRC_0	—	—	TGRC_3	TGRC_4	—
	TGRD_0			TGRD_3	TGRD_4	
	TGRF_0					
I/O pins	TIOC0A	TIOC1A* <sup>1</sup>	TIOC2A* <sup>1</sup>	TIOC3A	TIOC4A	Input pins
	TIOC0B	TIOC1B* <sup>1</sup>	TIOC2B* <sup>1</sup>	TIOC3B	TIOC4B	TIC5U
	TIOC0C			TIOC3C	TIOC4C	TIC5V
	TIOC0D			TIOC3D	TIOC4D	TIC5W
Counter clear function	TGR	TGR	TGR	TGR	TGR	TGR
	compare match or input capture	compare match or input capture	compare match or input capture	compare match or input capture	compare match or input capture	compare match or input capture
Compare match output	0 output	√	√	√	√	—
	1 output	√	√	√	√	—
	Toggle output	√	√	√	√	—
Input capture function	√	√	√	√	√	√
Synchronous operation	√	√	√	√	√	—
PWM mode 1	√	√	√	√	√	—
PWM mode 2	√	√	√	—	—	—
Complementary PWM mode	—	—	—	√	√	—
Reset PWM mode	—	—	—	√	√	—
AC synchronous motor drive mode	√	—	—	√	√	—

Item	Channel 0	Channel 1	Channel 2	Channel 3	Channel 4	Channel 5
Phase counting mode	—	√	√	—	—	—
Buffer operation	√	—	—	√	√	—
Dead time compensation counter function	—	—	—	—	—	√
A/D converter start trigger	TGRA_0 compare match or input capture	TGRA_1 compare match or input capture	TGRA_2 compare match or input capture	TGRA_3 compare match or input capture	TGRA_4 compare match or input capture	—
	TGRE_0 compare match				TCNT_4 underflow (trough) in complementary PWM mode	

Item	Channel 0	Channel 1	Channel 2	Channel 3	Channel 4	Channel 5
Interrupt sources	7 sources	4 sources	4 sources	5 sources	5 sources	3 sources
	<ul style="list-style-type: none"> <li>• Compare match or input capture 0A</li> <li>• Compare match or input capture 0B</li> <li>• Compare match or input capture 0C</li> <li>• Compare match or input capture 0D</li> <li>• Compare match 0E</li> <li>• Compare match 0F</li> <li>• Overflow</li> </ul>	<ul style="list-style-type: none"> <li>• Compare match or input capture 1A*<sup>2</sup></li> <li>• Compare match or input capture 1B*<sup>2</sup></li> <li>• Overflow</li> <li>• Underflow</li> </ul>	<ul style="list-style-type: none"> <li>• Compare match or input capture 2A*<sup>2</sup></li> <li>• Overflow</li> <li>• Underflow</li> </ul>	<ul style="list-style-type: none"> <li>• Compare match or input capture 3A</li> <li>• Compare match or input capture 3B</li> <li>• Compare match or input capture 3C</li> <li>• Compare match or input capture 3D</li> <li>• Overflow</li> </ul>	<ul style="list-style-type: none"> <li>• Compare match or input capture 4A</li> <li>• Compare match or input capture 4B</li> <li>• Compare match or input capture 4C</li> <li>• Compare match or input capture 4D</li> <li>• Overflow or underflow</li> </ul>	<ul style="list-style-type: none"> <li>• Compare match or input capture 5U</li> <li>• Compare match or input capture 5V</li> <li>• Compare match or input capture 5W</li> </ul>

Item	Channel 0	Channel 1	Channel 2	Channel 3	Channel 4	Channel 5
A/D converter start request delaying function	—	—	—	—	<ul style="list-style-type: none"> <li>A/D converter start request at a match between TADCOR A_4 and TCNT_4</li> <li>A/D converter start request at a match between TADCOR B_4 and TCNT_4</li> </ul>	—
Interrupt skipping function	—	—	—	<ul style="list-style-type: none"> <li>Skips TGRA_3 compare match interrupts</li> </ul>	<ul style="list-style-type: none"> <li>Skips TCIV_4 interrupts</li> </ul>	—

## [Legend]

√: Possible

—: Not possible

- Notes: 1. This pin is supported only by the SH7125.  
 2. Input capture is supported only by the SH7125.

Figure 9.1 shows a block diagram of the MTU2.

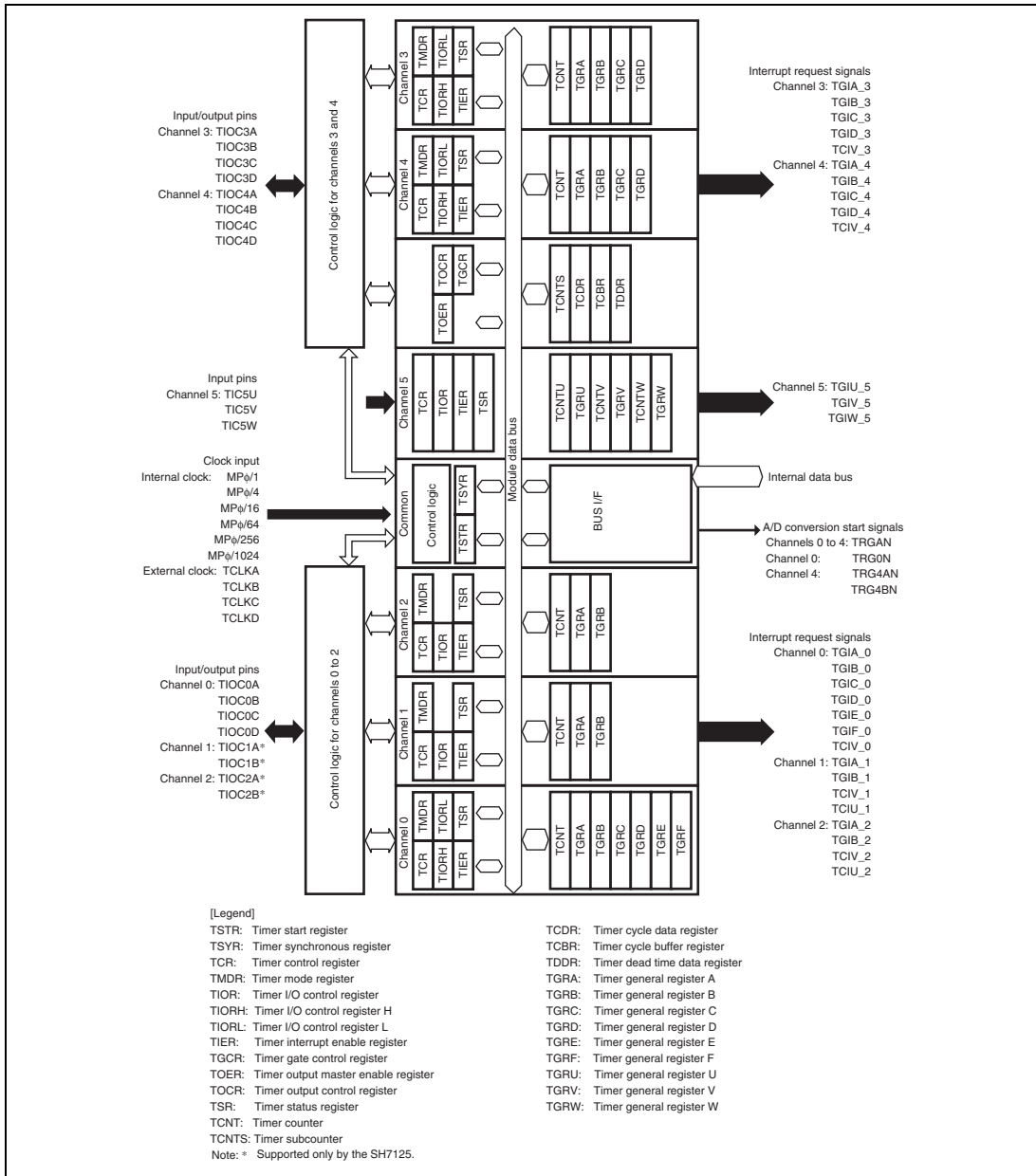


Figure 9.1 Block Diagram of MTU2



## 9.2 Input/Output Pins

**Table 9.2 Pin Configuration**

Channel	Pin Name	I/O	Function
Common	TCLKA	Input	External clock A input pin (Channel 1 phase counting mode A phase input)
	TCLKB	Input	External clock B input pin (Channel 1 phase counting mode B phase input)
	TCLKC	Input	External clock C input pin (Channel 2 phase counting mode A phase input)
	TCLKD	Input	External clock D input pin (Channel 2 phase counting mode B phase input)
0	TIOC0A	I/O	TGRA_0 input capture input/output compare output/PWM output pin
	TIOC0B	I/O	TGRB_0 input capture input/output compare output/PWM output pin
	TIOC0C	I/O	TGRC_0 input capture input/output compare output/PWM output pin
	TIOC0D	I/O	TGRD_0 input capture input/output compare output/PWM output pin
1	TIOC1A*	I/O	TGRA_1 input capture input/output compare output/PWM output pin
	TIOC1B*	I/O	TGRB_1 input capture input/output compare output/PWM output pin
2	TIOC2A*	I/O	TGRA_2 input capture input/output compare output/PWM output pin
	TIOC2B*	I/O	TGRB_2 input capture input/output compare output/PWM output pin
3	TIOC3A	I/O	TGRA_3 input capture input/output compare output/PWM output pin
	TIOC3B	I/O	TGRB_3 input capture input/output compare output/PWM output pin
	TIOC3C	I/O	TGRC_3 input capture input/output compare output/PWM output pin
	TIOC3D	I/O	TGRD_3 input capture input/output compare output/PWM output pin
4	TIOC4A	I/O	TGRA_4 input capture input/output compare output/PWM output pin
	TIOC4B	I/O	TGRB_4 input capture input/output compare output/PWM output pin
	TIOC4C	I/O	TGRC_4 input capture input/output compare output/PWM output pin
	TIOC4D	I/O	TGRD_4 input capture input/output compare output/PWM output pin
5	TIC5U	Input	TGRU_5 input capture input/external pulse input pin
	TIC5V	Input	TGRV_5 input capture input/external pulse input pin
	TIC5W	Input	TGRW_5 input capture input/external pulse input pin

Note: \* Supported only by the SH7125.

### 9.3 Register Descriptions

The MTU2 has the following registers. For details on register addresses and register states during each process, see section 20, List of Registers. To distinguish registers in each channel, an underscore and the channel number are added as a suffix to the register name; TCR for channel 0 is expressed as TCR\_0.

**Table 9.3 Register Configuration**

Register Name	Abbreviation	R/W	Initial value	Address	Access Size
Timer control register_3	TCR_3	R/W	H'00	H'FFFFC200	8, 16, 32
Timer control register_4	TCR_4	R/W	H'00	H'FFFFC201	8
Timer mode register_3	TMDR_3	R/W	H'00	H'FFFFC202	8, 16
Timer mode register_4	TMDR_4	R/W	H'00	H'FFFFC203	8
Timer I/O control register H_3	TIORH_3	R/W	H'00	H'FFFFC204	8, 16, 32
Timer I/O control register L_3	TIORL_3	R/W	H'00	H'FFFFC205	8
Timer I/O control register H_4	TIORH_4	R/W	H'00	H'FFFFC206	8, 16
Timer I/O control register L_4	TIORL_4	R/W	H'00	H'FFFFC207	8
Timer interrupt enable register_3	TIER_3	R/W	H'00	H'FFFFC208	8, 16
Timer interrupt enable register_4	TIER_4	R/W	H'00	H'FFFFC209	8
Timer output master enable register	TOER	R/W	H'C0	H'FFFFC20A	8
Timer gate control register	TGCR	R/W	H'80	H'FFFFC20D	8
Timer output control register 1	TOCR1	R/W	H'00	H'FFFFC20E	8, 16
Timer output control register 2	TOCR2	R/W	H'00	H'FFFFC20F	8
Timer counter_3	TCNT_3	R/W	H'0000	H'FFFFC210	16, 32
Timer counter_4	TCNT_4	R/W	H'0000	H'FFFFC212	16
Timer cycle data register	TCDR	R/W	H'FFFF	H'FFFFC214	16, 32
Timer dead time data register	TDDR	R/W	H'FFFF	H'FFFFC216	16
Timer general register A_3	TGRA_3	R/W	H'FFFF	H'FFFFC218	16, 32
Timer general register B_3	TGRB_3	R/W	H'FFFF	H'FFFFC21A	16
Timer general register A_4	TGRA_4	R/W	H'FFFF	H'FFFFC21C	16, 32
Timer general register B_4	TGRB_4	R/W	H'FFFF	H'FFFFC21E	16

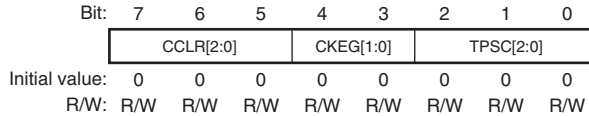
Register Name	Abbreviation	R/W	Initial value	Address	Access Size
Timer subcounter	TCNTS	R	H'0000	H'FFFFC220	16, 32
Timer cycle buffer register	TCBR	R/W	H'FFFF	H'FFFFC222	16
Timer general register C_3	TGRC_3	R/W	H'FFFF	H'FFFFC224	16, 32
Timer general register D_3	TGRD_3	R/W	H'FFFF	H'FFFFC226	16
Timer general register C_4	TGRC_4	R/W	H'FFFF	H'FFFFC228	16, 32
Timer general register D_4	TGRD_4	R/W	H'FFFF	H'FFFFC22A	16
Timer status register_3	TSR_3	R/W	H'C0	H'FFFFC22C	8, 16
Timer status register_4	TSR_4	R/W	H'C0	H'FFFFC22D	8
Timer interrupt skipping set register	TITCR	R/W	H'00	H'FFFFC230	8, 16
Timer interrupt skipping counter	TITCNT	R	H'00	H'FFFFC231	8
Timer buffer transfer set register	TBTER	R/W	H'00	H'FFFFC232	8
Timer dead time enable register	TDER	R/W	H'01	H'FFFFC234	8
Timer output level buffer register	TOLBR	R/W	H'00	H'FFFFC236	8
Timer buffer operation transfer mode register_3	TBTM_3	R/W	H'00	H'FFFFC238	8, 16
Timer buffer operation transfer mode register_4	TBTM_4	R/W	H'00	H'FFFFC239	8
Timer A/D converter start request control register	TADCR	R/W	H'0000	H'FFFFC240	16
Timer A/D converter start request cycle set register A_4	TADCORA_4	R/W	H'FFFF	H'FFFFC244	16, 32
Timer A/D converter start request cycle set register B_4	TADCORB_4	R/W	H'FFFF	H'FFFFC246	16
Timer A/D converter start request cycle set buffer register A_4	TADCOBRA_4	R/W	H'FFFF	H'FFFFC248	16, 32
Timer A/D converter start request cycle set buffer register B_4	TADCOBRB_4	R/W	H'FFFF	H'FFFFC24A	16

Register Name	Abbreviation	R/W	Initial value	Address	Access Size
Timer waveform control register	TWCR	R/W	H'00	H'FFFFC260	8
Timer start register	TSTR	R/W	H'00	H'FFFFC280	8, 16
Timer synchronous register	TSYR	R/W	H'00	H'FFFFC281	8
Timer read/write enable register	TRWER	R/W	H'01	H'FFFFC284	8
Timer control register_0	TCR_0	R/W	H'00	H'FFFFC300	8, 16, 32
Timer mode register_0	TMDR_0	R/W	H'00	H'FFFFC301	8
Timer I/O control register H_0	TIORH_0	R/W	H'00	H'FFFFC302	8, 16
Timer I/O control register L_0	TIORL_0	R/W	H'00	H'FFFFC303	8
Timer interrupt enable register_0	TIER_0	R/W	H'00	H'FFFFC304	8, 16, 32
Timer status register_0	TSR_0	R/W	H'C0	H'FFFFC305	8
Timer counter_0	TCNT_0	R/W	H'0000	H'FFFFC306	16
Timer general register A_0	TGRA_0	R/W	H'FFFF	H'FFFFC308	16, 32
Timer general register B_0	TGRB_0	R/W	H'FFFF	H'FFFFC30A	16
Timer general register C_0	TGRC_0	R/W	H'FFFF	H'FFFFC30C	16, 32
Timer general register D_0	TGRD_0	R/W	H'FFFF	H'FFFFC30E	16
Timer general register E_0	TGRE_0	R/W	H'FFFF	H'FFFFC320	16, 32
Timer general register F_0	TGRF_0	R/W	H'FFFF	H'FFFFC322	16
Timer interrupt enable register 2_0	TIER2_0	R/W	H'00	H'FFFFC324	8, 16
Timer status register 2_0	TSR2_0	R/W	H'C0	H'FFFFC325	8
Timer buffer operation transfer mode register_0	TBTM_0	R/W	H'00	H'FFFFC326	8
Timer control register_1	TCR_1	R/W	H'00	H'FFFFC380	8, 16
Timer mode register_1	TMDR_1	R/W	H'00	H'FFFFC381	8
Timer I/O control register_1	TIOR_1	R/W	H'00	H'FFFFC382	8
Timer interrupt enable register_1	TIER_1	R/W	H'00	H'FFFFC384	8, 16, 32
Timer status register_1	TSR_1	R/W	H'C0	H'FFFFC385	8

Register Name	Abbrevia- tion	R/W	Initial value	Address	Access Size
Timer counter_1	TCNT_1	R/W	H'0000	H'FFFFC386	16
Timer general register A_1	TGRA_1	R/W	H'FFFF	H'FFFFC388	16, 32
Timer general register B_1	TGRB_1	R/W	H'FFFF	H'FFFFC38A	16
Timer input capture control register	TICCR	R/W	H'00	H'FFFFC390	8
Timer control register_2	TCR_2	R/W	H'00	H'FFFFC400	8, 16
Timer mode register_2	TMDR_2	R/W	H'00	H'FFFFC401	8
Timer I/O control register_2	TIOR_2	R/W	H'00	H'FFFFC402	8
Timer interrupt enable register_2	TIER_2	R/W	H'00	H'FFFFC404	8, 16, 32
Timer status register_2	TSR_2	R/W	H'C0	H'FFFFC405	8
Timer counter_2	TCNT_2	R/W	H'0000	H'FFFFC406	16
Timer general register A_2	TGRA_2	R/W	H'FFFF	H'FFFFC408	16, 32
Timer general register B_2	TGRB_2	R/W	H'FFFF	H'FFFFC40A	16
Timer counter U_5	TCNTU_5	R/W	H'0000	H'FFFFC480	16, 32
Timer general register U_5	TGRU_5	R/W	H'FFFF	H'FFFFC482	16
Timer control register U_5	TCRU_5	R/W	H'00	H'FFFFC484	8
Timer I/O control register U_5	TIORU_5	R/W	H'00	H'FFFFC486	8
Timer counter V_5	TCNTV_5	R/W	H'0000	H'FFFFC490	16, 32
Timer general register V_5	TGRV_5	R/W	H'FFFF	H'FFFFC492	16
Timer control register V_5	TCRV_5	R/W	H'00	H'FFFFC494	8
Timer I/O control register V_5	TIORV_5	R/W	H'00	H'FFFFC496	8
Timer counter W_5	TCNTW_5	R/W	H'0000	H'FFFFC4A0	16, 32
Timer general register W_5	TGRW_5	R/W	H'FFFF	H'FFFFC4A2	16
Timer control register W_5	TCRW_5	R/W	H'00	H'FFFFC4A4	8
Timer I/O control register W_5	TIORW_5	R/W	H'00	H'FFFFC4A6	8
Timer status register_5	TSR_5	R/W	H'00	H'FFFFC4B0	8
Timer interrupt enable register_5	TIER_5	R/W	H'00	H'FFFFC4B2	8
Timer start register_5	TSTR_5	R/W	H'00	H'FFFFC4B4	8
Timer compare match clear register	TCNTCMPCLR	R/W	H'00	H'FFFFC4B6	8

### 9.3.1 Timer Control Register (TCR)

The TCR registers are 8-bit readable/writable registers that control the TCNT operation for each channel. The MTU2 has a total of eight TCR registers, one each for channels 0 to 4 and three (TCRU\_5, TCRV\_5, and TCRW\_5) for channel 5. TCR register settings should be conducted only when TCNT operation is stopped.



Bit	Bit Name	Initial Value	R/W	Description
7 to 5	CCLR[2:0]	000	R/W	Counter Clear 0 to 2  These bits select the TCNT counter clearing source. See tables 9.4 and 9.5 for details.
4, 3	CKEG[1:0]	00	R/W	Clock Edge 0 and 1  These bits select the input clock edge. When the input clock is counted using both edges, the input clock period is halved (e.g. $MP\phi/4$ both edges = $MP\phi/2$ rising edge). If phase counting mode is used on channels 1 and 2, this setting is ignored and the phase counting mode setting has priority. Internal clock edge selection is valid when the input clock is $MP\phi/4$ or slower. When $MP\phi/1$ , or the overflow/underflow of another channel is selected for the input clock, although values can be written, counter operation compiles with the initial value.  00: Count at rising edge 01: Count at falling edge 1x: Count at both edges
2 to 0	TPSC[2:0]	000	R/W	Time Prescaler 0 to 2  These bits select the TCNT counter clock. The clock source can be selected independently for each channel. See tables 9.6 to 9.10 for details.

[Legend]

x: Don't care

**Table 9.4 CCLR0 to CCLR2 (Channels 0, 3, and 4)**

Channel	Bit 7 CCLR2	Bit 6 CCLR1	Bit 5 CCLR0	Description
0, 3, 4	0	0	0	TCNT clearing disabled
			1	TCNT cleared by TGRA compare match/input capture
			1	TCNT cleared by counter clearing for another channel performing synchronous clearing/ synchronous operation* <sup>1</sup>
	1	0	0	TCNT clearing disabled
			1	TCNT cleared by TGRC compare match/input capture* <sup>2</sup>
			1	TCNT cleared by counter clearing for another channel performing synchronous clearing/ synchronous operation* <sup>1</sup>
	1	0	0	TCNT clearing disabled
			1	TCNT cleared by TGRD compare match/input capture* <sup>2</sup>
			1	TCNT cleared by counter clearing for another channel performing synchronous clearing/ synchronous operation* <sup>1</sup>

Notes: 1. Synchronous operation is set by setting the SYNC bit in TSYR to 1.  
 2. When TGRC or TGRD is used as a buffer register, TCNT is not cleared because the buffer register setting has priority, and compare match/input capture does not occur.

**Table 9.5 CCLR0 to CCLR2 (Channels 1 and 2)**

Channel	Bit 7 Reserved* <sup>2</sup>	Bit 6 CCLR1	Bit 5 CCLR0	Description
1, 2	0	0	0	TCNT clearing disabled
			1	TCNT cleared by TGRA compare match/input capture
			1	TCNT cleared by counter clearing for another channel performing synchronous clearing/ synchronous operation* <sup>1</sup>
		1	0	TCNT cleared by TGRB compare match/input capture
			1	TCNT cleared by counter clearing for another channel performing synchronous clearing/ synchronous operation* <sup>1</sup>

Notes: 1. Synchronous operation is selected by setting the SYNC bit in TSYR to 1.  
 2. Bit 7 is reserved in channels 1 and 2. It is always read as 0 and cannot be modified.

**Table 9.6 TPSC0 to TPSC2 (Channel 0)**

Channel	Bit 2 TPSC2	Bit 1 TPSC1	Bit 0 TPSC0	Description
0	0	0	0	Internal clock: counts on MP $\phi$ /1
			1	Internal clock: counts on MP $\phi$ /4
		1	0	Internal clock: counts on MP $\phi$ /16
			1	Internal clock: counts on MP $\phi$ /64
	1	0	0	External clock: counts on TCLKA pin input
			1	External clock: counts on TCLKB pin input
		1	0	External clock: counts on TCLKC pin input
			1	External clock: counts on TCLKD pin input

**Table 9.7 TPSC0 to TPSC2 (Channel 1)**

Channel	Bit 2 TPSC2	Bit 1 TPSC1	Bit 0 TPSC0	Description
1	0	0	0	Internal clock: counts on MP $\phi$ /1
			1	Internal clock: counts on MP $\phi$ /4
		1	0	Internal clock: counts on MP $\phi$ /16
			1	Internal clock: counts on MP $\phi$ /64
	1	0	0	External clock: counts on TCLKA pin input
			1	External clock: counts on TCLKB pin input
		1	0	Internal clock: counts on MP $\phi$ /256
			1	Counts on TCNT_2 overflow/underflow

Note: This setting is ignored when channel 1 is in phase counting mode.



**Table 9.8 TPSC0 to TPSC2 (Channel 2)**

Channel	Bit 2 TPSC2	Bit 1 TPSC1	Bit 0 TPSC0	Description
2	0	0	0	Internal clock: counts on MP $\phi$ /1
			1	Internal clock: counts on MP $\phi$ /4
		1	0	Internal clock: counts on MP $\phi$ /16
			1	Internal clock: counts on MP $\phi$ /64
	1	0	0	External clock: counts on TCLKA pin input
			1	External clock: counts on TCLKB pin input
		1	0	External clock: counts on TCLKC pin input
			1	Internal clock: counts on MP $\phi$ /1024

Note: This setting is ignored when channel 2 is in phase counting mode.

**Table 9.9 TPSC0 to TPSC2 (Channels 3 and 4)**

Channel	Bit 2 TPSC2	Bit 1 TPSC1	Bit 0 TPSC0	Description
3, 4	0	0	0	Internal clock: counts on MP $\phi$ /1
			1	Internal clock: counts on MP $\phi$ /4
		1	0	Internal clock: counts on MP $\phi$ /16
			1	Internal clock: counts on MP $\phi$ /64
	1	0	0	Internal clock: counts on MP $\phi$ /256
			1	Internal clock: counts on MP $\phi$ /1024
		1	0	External clock: counts on TCLKA pin input
			1	External clock: counts on TCLKB pin input

**Table 9.10 TPSC1 and TPSC0 (Channel 5)**

Channel	Bit 1 TPSC1	Bit 0 TPSC0	Description
5	0	0	Internal clock: counts on MP $\phi$ /1
		1	Internal clock: counts on MP $\phi$ /4
	1	0	Internal clock: counts on MP $\phi$ /16
		1	Internal clock: counts on MP $\phi$ /64

Note: Bits 7 to 2 are reserved in channel 5. These bits are always read as 0. The write value should always be 0.

### 9.3.2 Timer Mode Register (TMDR)

The TMDR registers are 8-bit readable/writable registers that are used to set the operating mode of each channel. The MTU2 has five TMDR registers, one each for channels 0 to 4. TMDR register settings should be changed only when TCNT operation is stopped.

Bit:	7	6	5	4	3	2	1	0
	-	BFE	BFB	BFA	MD[3:0]			
Initial value:	0	0	0	0	0	0	0	0
R/W:	-	R/W	R/W	R/W	R/W	R/W	R/W	R/W

Bit	Bit Name	Initial Value	R/W	Description
7	—	0	—	Reserved This bit is always read as 0. The write value should always be 0.
6	BFE	0	R/W	Buffer Operation E Specifies whether TGRE_0 and TGRF_0 are to operate in the normal way or to be used together for buffer operation. When TGRF is used as a buffer register, TGRF compare match is generated. In channels 1 to 4, this bit is reserved. It is always read as 0 and the write value should always be 0. 0: TGRE_0 and TGRF_0 operate normally 1: TGRE_0 and TGRF_0 used together for buffer operation

Bit	Bit Name	Initial Value	R/W	Description
5	BFB	0	R/W	<p>Buffer Operation B</p> <p>Specifies whether TGRB is to operate in the normal way, or TGRB and TGRD are to be used together for buffer operation. When TGRD is used as a buffer register, TGRD input capture/output compare do not take place in modes other than complementary PWM mode, but compare match with TGRD occurs in complementary PWM mode. Since the TGFD flag will be set if a compare match occurs during Tb interval in complementary PWM mode, the TGIED bit in timer interrupt enable register 3/4 (TIER_3/4) should be cleared to 0.</p> <p>In channels 1 and 2, which have no TGRD, bit 5 is reserved. It is always read as 0 and cannot be modified.</p> <p>0: TGRB and TGRD operate normally 1: TGRB and TGRD used together for buffer operation</p>
4	BFA	0	R/W	<p>Buffer Operation A</p> <p>Specifies whether TGRB is to operate in the normal way, or TGRB and TGRD are to be used together for buffer operation. When TGRD is used as a buffer register, TGRD input capture/output compare do not take place in modes other than complementary PWM mode, but compare match with TGRD occurs in complementary PWM mode. Since the TGFD flag will be set if a compare match occurs during Tb interval in complementary PWM mode, the TGIED bit in timer interrupt enable register 3/4 (TIER_3/4) should be cleared to 0.</p> <p>In channels 1 and 2, which have no TGRC, bit 4 is reserved. It is always read as 0 and cannot be modified.</p> <p>0: TGRA and TGRC operate normally 1: TGRA and TGRC used together for buffer operation</p>
3 to 0	MD[3:0]	0000	R/W	<p>Modes 0 to 3</p> <p>These bits are used to set the timer operating mode. See table 9.11 for details.</p>

**Table 9.11 Setting of Operation Mode by Bits MD0 to MD3**

Bit 3 MD3	Bit 2 MD2	Bit 1 MD1	Bit 0 MD0	Description	
0	0	0	0	Normal operation	
			1	Setting prohibited	
		1	0	PWM mode 1	
			1	PWM mode 2* <sup>1</sup>	
	1	0	0	Phase counting mode 1* <sup>2</sup>	
			1	Phase counting mode 2* <sup>2</sup>	
		1	0	Phase counting mode 3* <sup>2</sup>	
			1	Phase counting mode 4* <sup>2</sup>	
1	0	0	0	Reset synchronous PWM mode* <sup>3</sup>	
			1	Setting prohibited	
		1	x	Setting prohibited	
	1	0	0	Setting prohibited	
			1	Complementary PWM mode 1 (transmit at crest)* <sup>3</sup>	
			1	Complementary PWM mode 2 (transmit at trough)* <sup>3</sup>	
		1	0	0	Complementary PWM mode 2 (transmit at trough)* <sup>3</sup>
				1	Complementary PWM mode 2 (transmit at crest and trough)* <sup>3</sup>

[Legend]

x: Don't care

- Notes:
1. PWM mode 2 cannot be set for channels 3 and 4.
  2. Phase counting mode cannot be set for channels 0, 3, and 4.
  3. Reset synchronous PWM mode and complementary PWM mode can only be set for channel 3. When channel 3 is set to reset synchronous PWM mode or complementary PWM mode, the channel 4 settings become ineffective and automatically conform to the channel 3 settings. However, do not set channel 4 to reset synchronous PWM mode or complementary PWM mode. Reset synchronous PWM mode and complementary PWM mode cannot be set for channels 0, 1, and 2.

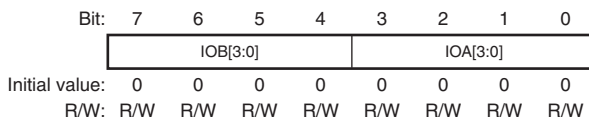
### 9.3.3 Timer I/O Control Register (TIOR)

The TIOR registers are 8-bit readable/writable registers that control the TGR registers. The MTU2 has a total of eleven TIOR registers, two each for channels 0, 3, and 4, one each for channels 1 and 2, and three (TIORU\_5, TIORV\_5, and TIORW\_5) for channel 5.

TIOR is set when the setting of TMDR is in normal operation, PWM mode, and phase counting mode. The initial output specified by TIOR is valid when the counter is stopped (the CST bit in TSTR is cleared to 0). Note also that, in PWM mode 2, the output at the point at which the counter is cleared to 0 is specified.

When TGRC or TGRD is designated for buffer operation, this setting is invalid and the register operates as a buffer register.

- TIORH\_0, TIOR\_1, TIOR\_2, TIORH\_3, TIORH\_4



Bit	Bit Name	Initial Value	R/W	Description
7 to 4	IOB[3:0]	0000	R/W	I/O Control B0 to B3 Specify the function of TGRB. See the following tables. TIORH_0: Table 9.12 TIOR_1: Table 9.14 TIOR_2: Table 9.15 TIORH_3: Table 9.16 TIORH_4: Table 9.18
3 to 0	IOA[3:0]	0000	R/W	I/O Control A0 to A3 Specify the function of TGRA. See the following tables. TIORH_0: Table 9.20 TIOR_1: Table 9.22 TIOR_2: Table 9.23 TIORH_3: Table 9.24 TIORH_4: Table 9.26

- TIORL\_0, TIORL\_3, TIORL\_4

Bit:	7	6	5	4	3	2	1	0
	IOD[3:0]				IOC[3:0]			
Initial value:	0	0	0	0	0	0	0	0
R/W:	R/W	R/W	R/W	R/W	R/W	R/W	R/W	R/W

Bit	Bit Name	Initial Value	R/W	Description
7 to 4	IOD[3:0]	0000	R/W	I/O Control D0 to D3 Specify the function of TGRD. See the following tables. TIORL_0: Table 9.13 TIORL_3: Table 9.17 TIORL_4: Table 9.19
3 to 0	IOC[3:0]	0000	R/W	I/O Control C0 to C3 Specify the function of TGRD. See the following tables. TIORL_0: Table 9.21 TIORL_3: Table 9.25 TIORL_4: Table 9.27

- TIORU\_5, TIORV\_5, TIORW\_5

Bit name:	7	6	5	4	3	2	1	0
	-	-	-	IOC[4:0]				
Initial value:	0	0	0	0	0	0	0	0
R/W:	R	R	R	R/W	R/W	R/W	R/W	R/W

Bit	Bit Name	Initial Value	R/W	Description
7 to 5	—	All 0	R	Reserved These bits are always read as 0. The write value should always be 0.
4 to 0	IOC[4:0]	00000	R/W	I/O Control C0 to C4 Specify the function of TGRU_5, TGRV_5, and TGRW_5. For details, see table 9.28.

Table 9.12 TIORH\_0 (Channel 0)

				Description		
Bit 7 IOB3	Bit 6 IOB2	Bit 5 IOB1	Bit 4 IOB0	TGRB_0 Function	TIOC0B Pin Function	
0	0	0	0	Output compare register	Output retained*	
			1		Initial output is 0 0 output at compare match	
		1	0		Initial output is 0 1 output at compare match	
			1		Initial output is 0 Toggle output at compare match	
		1	0		0	Output retained Initial output is 1 0 output at compare match
					1	Initial output is 1 1 output at compare match
	1	0	0	0	Input capture register	Input capture at rising edge
				1	Input capture at falling edge	
		1	x	x	1	Input capture at both edges
					1	Capture input source is channel 1/count clock Input capture at TCNT_1 count-up/count-down

[Legend]

x: Don't care

Note: \* After power-on reset, 0 is output until TIOR is set.

**Table 9.13 TIORL\_0 (Channel 0)**

				Description			
Bit 7 IOD3	Bit 6 IOD2	Bit 5 IOD1	Bit 4 IOD0	TGRD_0 Function	TIOC0D Pin Function		
0	0	0	0	Output compare register*2	Output retained*1		
			1		Initial output is 0		
		-----			1	0	0 output at compare match
		-----				0	Initial output is 0
		-----			1	1	1 output at compare match
		-----				1	Initial output is 0
	-----		1	0	Toggle output at compare match		
	-----			0	Output retained		
	-----		1	1	Initial output is 1		
	-----			0	0 output at compare match		
	-----		1	1	Initial output is 1		
	-----			0	1 output at compare match		
-----		1	1	Initial output is 1			
-----			1	Toggle output at compare match			
1	0	0	0	Input capture register*2	Input capture at rising edge		
			1		Input capture at falling edge		
		-----			1	x	Input capture at both edges
		-----				1	x
-----		1	x	Input capture at TCNT_1 count-up/count-down			
-----			1	x			

[Legend]

x: Don't care

Notes: 1. After power-on reset, 0 is output until TIOR is set.

2. When the BFB bit in TMDR\_0 is set to 1 and TGRD\_0 is used as a buffer register, this setting is invalid and input capture/output compare is not generated.



Table 9.14 TIOR\_1 (Channel 1)

				Description	
Bit 7 IOB3	Bit 6 IOB2	Bit 5 IOB1	Bit 4 IOB0	TGRB_1 Function	TIOC1B Pin Function* <sup>2</sup>
0	0	0	0	Output compare register	Output retained* <sup>1</sup>
			1		Initial output is 0 0 output at compare match
		1	0		Initial output is 0 1 output at compare match
			1		Initial output is 0 Toggle output at compare match
	1	0	0	Output retained	
			1	Initial output is 1 0 output at compare match	
		1	0	Initial output is 1 1 output at compare match	
			1	Initial output is 1 Toggle output at compare match	
1	0	0	Input capture register	Input capture at rising edge	
		1		Input capture at falling edge	
	1	x		Input capture at both edges	
		1		x	Input capture at generation of TGRC_0 compare match/input capture

[Legend]

x: Don't care

- Notes: 1. After power-on reset, 0 is output until TIOR is set.  
2. The TIOC1B pin input/output function is supported only by the SH7125.

**Table 9.15 TIOR\_2 (Channel 2)**

				Description	
Bit 7 IOB3	Bit 6 IOB2	Bit 5 IOB1	Bit 4 IOB0	TGRB_2 Function	TIOC2B Pin Function* <sup>2</sup>
0	0	0	0	Output compare register	Output retained* <sup>1</sup>
			1		Initial output is 0
			0		0 output at compare match
		1	0		Initial output is 0
			1		1 output at compare match
			1		Initial output is 0
	1	0	0	Toggle output at compare match	
			1	Output retained	
			1	Initial output is 1	
		1	0	0 output at compare match	
			1	Initial output is 1	
			1	1 output at compare match	
1	x	0	Input capture register	Initial output is 1	
		1		Toggle output at compare match	
		x		Input capture at rising edge	
	1	1		Input capture at falling edge	
		1		Input capture at both edges	
		x			

[Legend]

x: Don't care

Notes: 1. After power-on reset, 0 is output until TIOR is set.

2. The TIOC2B pin input/output function is supported only by the SH7125.

Table 9.16 TIORH\_3 (Channel 3)

				Description	
Bit 7 IOB3	Bit 6 IOB2	Bit 5 IOB1	Bit 4 IOB0	TGRB_3 Function	TIOC3B Pin Function
0	0	0	0	Output compare register	Output retained*
			1		Initial output is 0 0 output at compare match
		1	0		Initial output is 0 1 output at compare match
			1		Initial output is 0 Toggle output at compare match
	1	0	0	Output retained Initial output is 1	
			1	0 output at compare match	
		1	0	Initial output is 1 1 output at compare match	
			1	Initial output is 1 Toggle output at compare match	
1	x	0	0	Input capture register	Input capture at rising edge
			1		Input capture at falling edge
		1	x		Input capture at both edges

[Legend]

x: Don't care

Note: \* After power-on reset, 0 is output until TIOR is set.

**Table 9.17 TIORL\_3 (Channel 3)**

Bit 7 IOD3	Bit 6 IOD2	Bit 5 IOD1	Bit 4 IOD0	Description	
				TGRD_3 Function	TIOC3D Pin Function
0	0	0	0	Output compare register*2	Output retained*1
			1		Initial output is 0
			0		0 output at compare match
		1	0		Initial output is 0
			0		1 output at compare match
			1		Initial output is 0
	1	0	0	Output compare register*2	Toggle output at compare match
			1		Output retained
			0		Initial output is 1
		1	0		0 output at compare match
			0		Initial output is 1
			1		1 output at compare match
1	x	0	Input capture register*2	Initial output is 1	
		0		Toggle output at compare match	
		1		Input capture at rising edge	
	1	0		Input capture at falling edge	
		1		Input capture at both edges	
		x			

[Legend]

x: Don't care

- Notes: 1. After power-on reset, 0 is output until TIOR is set.  
 2. When the BFB bit in TMDR\_3 is set to 1 and TGRD\_3 is used as a buffer register, this setting is invalid and input capture/output compare is not generated.

Table 9.18 TIORH\_4 (Channel 4)

				Description	
Bit 7 IOB3	Bit 6 IOB2	Bit 5 IOB1	Bit 4 IOB0	TGRB_4 Function	TIOC4B Pin Function
0	0	0	0	Output compare register	Output retained*
			1		Initial output is 0 0 output at compare match
		1	0		Initial output is 0 1 output at compare match
			1		Initial output is 0 Toggle output at compare match
	1	0	0	Output retained	
			1	Initial output is 1 0 output at compare match	
		1	0	Initial output is 1 1 output at compare match	
			1	Initial output is 1 Toggle output at compare match	
1	x	0	Input capture register	Input capture at rising edge	
		1		Input capture at falling edge	
		1		Input capture at both edges	

[Legend]

x: Don't care

Note: \* After power-on reset, 0 is output until TIOR is set.

**Table 9.19 TIORL\_4 (Channel 4)**

				Description			
Bit 7 IOD3	Bit 6 IOD2	Bit 5 IOD1	Bit 4 IOD0	TGRD_4 Function	TIOC4D Pin Function		
0	0	0	0	Output compare register*2	Output retained*1		
			1		Initial output is 0		
			0		0 output at compare match		
			1		1 output at compare match		
		1	0	0	0	Input capture register*2	Input capture at rising edge
					1		Input capture at falling edge
					0		0 output at compare match
					1		1 output at compare match
		1	0	1	0	Input capture register*2	Initial output is 1
					1		Initial output is 0
					0		0 output at compare match
					1		1 output at compare match
1	0	1	0	Input capture register*2	Initial output is 1		
			1		Initial output is 0		
			0		0 output at compare match		
			1		1 output at compare match		
1	x	0	0	Input capture register*2	Initial output is 1		
			1		Initial output is 0		
			0		0 output at compare match		
			1		1 output at compare match		
1	x	1	0	Input capture register*2	Initial output is 1		
			1		Initial output is 0		
			0		0 output at compare match		
			1		1 output at compare match		
1	x	1	0	Input capture register*2	Initial output is 1		
			1		Initial output is 0		
			0		0 output at compare match		
			1		1 output at compare match		
1	x	1	0	Input capture register*2	Initial output is 1		
			1		Initial output is 0		
			0		0 output at compare match		
			1		1 output at compare match		

[Legend]

x: Don't care

- Notes: 1. After power-on reset, 0 is output until TIOR is set.
2. When the BFB bit in TMDR\_4 is set to 1 and TGRD\_4 is used as a buffer register, this setting is invalid and input capture/output compare is not generated.

**Table 9.20 TIORH\_0 (Channel 0)**

				Description	
Bit 3 IOA3	Bit 2 IOA2	Bit 1 IOA1	Bit 0 IOA0	TGRA_0 Function	TIOC0A Pin Function
0	0	0	0	Output compare register	Output retained*
			1		Initial output is 0 0 output at compare match
		1	0		Initial output is 0 1 output at compare match
			1		Initial output is 0 Toggle output at compare match
	1	0	0	Output retained Initial output is 1 0 output at compare match	
			1	Initial output is 1 1 output at compare match	
		1	0	Initial output is 1 1 output at compare match	
			1	Initial output is 1 Toggle output at compare match	
1	0	0	Input capture register	Input capture at rising edge	
		1		Input capture at falling edge	
	1	x		Input capture at both edges	
		1		x	Capture input source is channel 1/count clock Input capture at TCNT_1 count-up/count-down

[Legend]

x: Don't care

Note: \* After power-on reset, 0 is output until TIOR is set.

**Table 9.21 TIORL\_0 (Channel 0)**

				Description		
Bit 3 IOC3	Bit 2 IOC2	Bit 1 IOC1	Bit 0 IOC0	TGRC_0 Function	TIOC0C Pin Function	
0	0	0	0	Output compare register*2	Output retained*1	
			1		Initial output is 0	
			0		0 output at compare match	
		1	0		Initial output is 0	
			1		1 output at compare match	
			1		Initial output is 0	
	1	0	0	Toggle output at compare match		
			1	Output retained		
			1	Initial output is 1		
		1	0	0	0 output at compare match	
				1	Initial output is 1	
				1	1 output at compare match	
1	0	0	0	Initial output is 1		
			1	Toggle output at compare match		
			1	Input capture at rising edge		
		1	x	0	Input capture register*2	Input capture at falling edge
				1	Input capture at both edges	
				x	Input capture at both edges	
1	1	x	x	Capture input source is channel 1/count clock		
				Input capture at TCNT_1 count-up/count-down		

## [Legend]

x: Don't care

- Notes: 1. After power-on reset, 0 is output until TIOR is set.
2. When the BFA bit in TMDR\_0 is set to 1 and TGRC\_0 is used as a buffer register, this setting is invalid and input capture/output compare is not generated.



Table 9.22 TIOR\_1 (Channel 1)

				Description	
Bit 3 IOA3	Bit 2 IOA2	Bit 1 IOA1	Bit 0 IOA0	TGRA_1 Function	TIOC1A Pin Function* <sup>2</sup>
0	0	0	0	Output compare register	Output retained* <sup>1</sup>
			1		Initial output is 0 0 output at compare match
		1	0		Initial output is 0 1 output at compare match
			1		Initial output is 0 Toggle output at compare match
	1	0	0	Output retained	
			1	Initial output is 1 0 output at compare match	
		1	0	Initial output is 1 1 output at compare match	
			1	Initial output is 1 Toggle output at compare match	
1	0	0	Input capture register	Input capture at rising edge	
		1		Input capture at falling edge	
	1	x		Input capture at both edges	
		1		x	Input capture at generation of channel 0/TGRA_0 compare match/input capture

[Legend]

x: Don't care

Notes: 1. After power-on reset, 0 is output until TIOR is set.

2. The TIOC1A pin input/output function is supported only by the SH7125.

Table 9.23 TIOR\_2 (Channel 2)

Bit 3 IOA3	Bit 2 IOA2	Bit 1 IOA1	Bit 0 IOA0	Description	
				TGRA_2 Function	TIOC2A Pin Function* <sup>2</sup>
0	0	0	0	Output compare register	Output retained* <sup>1</sup>
			1		Initial output is 0
			0		0 output at compare match
		1	0		Initial output is 0
			1		1 output at compare match
			1		Initial output is 0
	1	0	0	Toggle output at compare match	
			1	Output retained	
			1	Initial output is 1	
		1	0	0 output at compare match	
			1	Initial output is 1	
			1	1 output at compare match	
1	x	0	Input capture register	Initial output is 1	
		1		Toggle output at compare match	
		x		Input capture at rising edge	
	1	1		Input capture at falling edge	
		1		Input capture at both edges	
		x			

[Legend]

x: Don't care

Notes: 1. After power-on reset, 0 is output until TIOR is set.

2. The TIOC2A pin input/output function is supported only by the SH7125.

Table 9.24 TIORH\_3 (Channel 3)

					Description	
Bit 3 IOA3	Bit 2 IOA2	Bit 1 IOA1	Bit 0 IOA0	TGRA_3 Function	TIOC3A Pin Function	
0	0	0	0	Output compare register	Output retained*	
			1		Initial output is 0 0 output at compare match	
		1	0	Initial output is 0 1 output at compare match		
			1	Initial output is 0 Toggle output at compare match		
	1	0	0	Output retained		
			1	Initial output is 1 0 output at compare match		
		1	0	Initial output is 1 1 output at compare match		
			1	Initial output is 1 Toggle output at compare match		
1	x	0	0	Input capture register	Input capture at rising edge	
			1		Input capture at falling edge	
		1	x	Input capture at both edges		

[Legend]

x: Don't care

Note: \* After power-on reset, 0 is output until TIOR is set.

Table 9.25 TIORL\_3 (Channel 3)

Bit 3 IOC3	Bit 2 IOC2	Bit 1 IOC1	Bit 0 IOC0	Description	
				TGRC_3 Function	TIOC3C Pin Function
0	0	0	0	Output compare register*2	Output retained*1
			1		Initial output is 0
			0		0 output at compare match
		1	0		Initial output is 0
			1		1 output at compare match
			1		Initial output is 0
	1	0	0	Toggle output at compare match	
			1	Output retained	
			1	Initial output is 1	
		1	0	0 output at compare match	
			1	Initial output is 1	
			1	1 output at compare match	
1	x	0	Initial output is 1		
		1	Toggle output at compare match		
		x	Input capture at rising edge		
1	x	0	Input capture register*2	Input capture at falling edge	
		1	Input capture at both edges		
		x	Input capture at both edges		

[Legend]

x: Don't care

- Notes: 1. After power-on reset, 0 is output until TIOR is set.
2. When the BFA bit in TMDR\_3 is set to 1 and TGRC\_3 is used as a buffer register, this setting is invalid and input capture/output compare is not generated.

Table 9.26 TIORH\_4 (Channel 4)

					Description		
Bit 3 IOA3	Bit 2 IOA2	Bit 1 IOA1	Bit 0 IOA0	TGRA_4 Function	TIOC4A Pin Function		
0	0	0	0	Output compare register	Output retained*		
			1		Initial output is 0 0 output at compare match		
		1	0	Initial output is 0 1 output at compare match			
			1	Initial output is 0 Toggle output at compare match			
		1	0	0	Output retained		
				1	Initial output is 1 0 output at compare match		
	1		0	Initial output is 1 1 output at compare match			
			1	Initial output is 1 Toggle output at compare match			
	1	x	0	0	Input capture register	Input capture at rising edge	
				1		Input capture at falling edge	
			1	x	Input capture at both edges		

[Legend]

x: Don't care

Note: \* After power-on reset, 0 is output until TIOR is set.

Table 9.27 TIORL\_4 (Channel 4)

Bit 3 IOC3	Bit 2 IOC2	Bit 1 IOC1	Bit 0 IOC0	Description		
				TGRC_4 Function	TIOC4C Pin Function	
0	0	0	0	Output compare register*2	Output retained*1	
			1		Initial output is 0	
		-----			0	0 output at compare match
		1	0		Initial output is 0	
			1		1 output at compare match	
		-----			1	Initial output is 0
	-----		1	Toggle output at compare match		
	1	0	0	0	Output retained	
				1	Initial output is 1	
		-----		0	0 output at compare match	
		1	0	Initial output is 1		
			1	1 output at compare match		
-----		1	Initial output is 1			
-----		1	Toggle output at compare match			
1	x	0	0	Input capture register*2	Input capture at rising edge	
			1		Input capture at falling edge	
		1	x		Input capture at both edges	

[Legend]

x: Don't care

- Notes: 1. After power-on reset, 0 is output until TIOR is set.  
 2. When the BFA bit in TMDR\_4 is set to 1 and TGRC\_4 is used as a buffer register, this setting is invalid and input capture/output compare is not generated.

**Table 9.28 TIORU\_5, TIORV\_5, and TIORW\_5 (Channel 5)**

						Description							
Bit 4 IOC4	Bit 3 IOC3	Bit 2 IOC2	Bit 1 IOC1	Bit 0 IOC0	TGRU_5, TGRV_5, and TGRW_5 Function	TIC5U, TIC5V, and TIC5W Pin Function							
0	0	0	0	0	Compare match register	Compare match							
				1		Setting prohibited							
				1		x	Setting prohibited						
				1		x	x	Setting prohibited					
				1		x	x	x	Setting prohibited				
				1		0	0	0	Input capture register	Setting prohibited			
1	0	0	0	1	Input capture at rising edge								
				1	0	Input capture at falling edge							
				1	Input capture at both edges								
				1	x	x	Setting prohibited						
				1	0	0	0	0		Setting prohibited			
								1		Measurement of low pulse width of external input signal Capture at trough in complementary PWM mode			
								1		0	Measurement of low pulse width of external input signal Capture at crest in complementary PWM mode		
								1		Measurement of low pulse width of external input signal Capture at crest and trough in complementary PWM mode			
								1		0	0	Setting prohibited	
								1		Measurement of high pulse width of external input signal Capture at trough in complementary PWM mode			
								1		0	Measurement of high pulse width of external input signal Capture at crest in complementary PWM mode		
								1		Measurement of high pulse width of external input signal Capture at crest and trough in complementary PWM mode			

[Legend]

x: Don't care

### 9.3.4 Timer Compare Match Clear Register (TCNTCMPCLR)

TCNTCMPCLR is an 8-bit readable/writable register that specifies requests to clear TCNTU\_5, TCNTV\_5, and TCNTW\_5. The MTU2 has one TCNTCMPCLR in channel 5.

Bit:	7	6	5	4	3	2	1	0
	-	-	-	-	-	CMP CLR5U	CMP CLR5V	CMP CLR5W
Initial value:	0	0	0	0	0	0	0	0
R/W:	R	R	R	R	R	R/W	R/W	R/W

Bit	Bit Name	Initial Value	R/W	Description
7 to 3	—	All 0	R	Reserved These bits are always read as 0. The write value should always be 0.
2	CMPCLR5U	0	R/W	TCNT Compare Clear 5U Enables or disables requests to clear TCNTU_5 at TGRU_5 compare match or input capture. 0: Disables TCNTU_5 to be cleared to H'0000 at TCNTU_5 and TGRU_5 compare match or input capture 1: Enables TCNTU_5 to be cleared to H'0000 at TCNTU_5 and TGRU_5 compare match or input capture
1	CMPCLR5V	0	R/W	TCNT Compare Clear 5V Enables or disables requests to clear TCNTV_5 at TGRV_5 compare match or input capture. 0: Disables TCNTV_5 to be cleared to H'0000 at TCNTV_5 and TGRV_5 compare match or input capture 1: Enables TCNTV_5 to be cleared to H'0000 at TCNTV_5 and TGRV_5 compare match or input capture



Bit	Bit Name	Initial Value	R/W	Description
0	CMPCLR5W	0	R/W	<p>TCNT Compare Clear 5W</p> <p>Enables or disables requests to clear TCNTW_5 at TGRW_5 compare match or input capture.</p> <p>0: Disables TCNTW_5 to be cleared to H'0000 at TCNTW_5 and TGRW_5 compare match or input capture</p> <p>1: Enables TCNTW_5 to be cleared to H'0000 at TCNTW_5 and TGRW_5 compare match or input capture</p>

### 9.3.5 Timer Interrupt Enable Register (TIER)

The TIER registers are 8-bit readable/writable registers that control enabling or disabling of interrupt requests for each channel. The MTU2 has seven TIER registers, two for channel 0 and one each for channels 1 to 5.

- TIER\_0, TIER\_1, TIER\_2, TIER\_3, TIER\_4

Bit:	7	6	5	4	3	2	1	0
	TTGE	TTGE2	TCIEU	TCIEV	TGIED	TGIEC	TGIEB	TGIEA
Initial value:	0	0	0	0	0	0	0	0
R/W:	R/W	R/W	R/W	R/W	R/W	R/W	R/W	R/W

Bit	Bit Name	Initial Value	R/W	Description
7	TTGE	0	R/W	<p>A/D Converter Start Request Enable</p> <p>Enables or disables generation of A/D converter start requests by TGRA input capture/compare match.</p> <p>0: A/D converter start request generation disabled</p> <p>1: A/D converter start request generation enabled</p>

Bit	Bit Name	Initial Value	R/W	Description
6	TTGE2	0	R/W	<p>A/D Converter Start Request Enable 2</p> <p>Enables or disables generation of A/D converter start requests by TCNT_4 underflow (trough) in complementary PWM mode.</p> <p>In channels 0 to 3, bit 6 is reserved. It is always read as 0 and the write value should always be 0.</p> <p>0: A/D converter start request generation by TCNT_4 underflow (trough) disabled</p> <p>1: A/D converter start request generation by TCNT_4 underflow (trough) enabled</p>
5	TCIEU	0	R/W	<p>Underflow Interrupt Enable</p> <p>Enables or disables interrupt requests (TCIU) by the TCFU flag when the TCFU flag in TSR is set to 1 in channels 1 and 2.</p> <p>In channels 0, 3, and 4, bit 5 is reserved. It is always read as 0 and the write value should always be 0.</p> <p>0: Interrupt requests (TCIU) by TCFU disabled</p> <p>1: Interrupt requests (TCIU) by TCFU enabled</p>
4	TCIEV	0	R/W	<p>Overflow Interrupt Enable</p> <p>Enables or disables interrupt requests (TCIV) by the TCFV flag when the TCFV flag in TSR is set to 1.</p> <p>0: Interrupt requests (TCIV) by TCFV disabled</p> <p>1: Interrupt requests (TCIV) by TCFV enabled</p>
3	TGIED	0	R/W	<p>TGR Interrupt Enable D</p> <p>Enables or disables interrupt requests (TGID) by the TGFD bit when the TGFD bit in TSR is set to 1 in channels 0, 3, and 4.</p> <p>In channels 1 and 2, bit 3 is reserved. It is always read as 0 and the write value should always be 0.</p> <p>0: Interrupt requests (TGID) by TGFD bit disabled</p> <p>1: Interrupt requests (TGID) by TGFD bit enabled</p>

Bit	Bit Name	Initial Value	R/W	Description
2	TGIEC	0	R/W	<p>TGR Interrupt Enable C</p> <p>Enables or disables interrupt requests (TGIC) by the TGFC bit when the TGFC bit in TSR is set to 1 in channels 0, 3, and 4.</p> <p>In channels 1 and 2, bit 2 is reserved. It is always read as 0 and the write value should always be 0.</p> <p>0: Interrupt requests (TGIC) by TGFC bit disabled 1: Interrupt requests (TGIC) by TGFC bit enabled</p>
1	TGIEB	0	R/W	<p>TGR Interrupt Enable B</p> <p>Enables or disables interrupt requests (TGIB) by the TGFB bit when the TGFB bit in TSR is set to 1.</p> <p>0: Interrupt requests (TGIB) by TGFB bit disabled 1: Interrupt requests (TGIB) by TGFB bit enabled</p>
0	TGIEA	0	R/W	<p>TGR Interrupt Enable A</p> <p>Enables or disables interrupt requests (TGIA) by the TGFA bit when the TGFA bit in TSR is set to 1.</p> <p>0: Interrupt requests (TGIA) by TGFA bit disabled 1: Interrupt requests (TGIA) by TGFA bit enabled</p>

## • TIER2\_0

Bit:	7	6	5	4	3	2	1	0
	TTGE2	-	-	-	-	-	TGIEF	TGIEE
Initial value:	0	0	0	0	0	0	0	0
R/W:	R/W	R	R	R	R	R	R/W	R/W

Bit	Bit Name	Initial Value	R/W	Description
7	TTGE2	0	R/W	<p>A/D Converter Start Request Enable 2</p> <p>Enables or disables generation of A/D converter start requests by compare match between TCNT_0 and TGRE_0.</p> <p>0: A/D converter start request generation by compare match between TCNT_0 and TGRE_0 disabled</p> <p>1: A/D converter start request generation by compare match between TCNT_0 and TGRE_0 enabled</p>
6 to 2	—	All 0	R	<p>Reserved</p> <p>These bits are always read as 0. The write value should always be 0.</p>
1	TGIEF	0	R/W	<p>TGR Interrupt Enable F</p> <p>Enables or disables interrupt requests by compare match between TCNT_0 and TGRF_0.</p> <p>0: Interrupt requests (TGIF) by TGFE bit disabled</p> <p>1: Interrupt requests (TGIF) by TGFE bit enabled</p>
0	TGIEE	0	R/W	<p>TGR Interrupt Enable E</p> <p>Enables or disables interrupt requests by compare match between TCNT_0 and TGRE_0.</p> <p>0: Interrupt requests (TGIE) by TGEE bit disabled</p> <p>1: Interrupt requests (TGIE) by TGEE bit enabled</p>

- TIER\_5

Bit:	7	6	5	4	3	2	1	0
	-	-	-	-	-	TGIE5U	TGIE5V	TGIE5W
Initial value:	0	0	0	0	0	0	0	0
R/W:	R	R	R	R	R	R/W	R/W	R/W

Bit	Bit Name	Initial Value	R/W	Description
7 to 3	—	All 0	R	Reserved These bits are always read as 0. The write value should always be 0.
2	TGIE5U	0	R/W	TGR Interrupt Enable 5U Enables or disables interrupt requests (TGIU_5) issued when the CMFU5 bit in TSR_5 is set to 1. 0: Interrupt requests (TGIU_5) disabled 1: Interrupt requests (TGIU_5) enabled
1	TGIE5V	0	R/W	TGR Interrupt Enable 5V Enables or disables interrupt requests (TGIV_5) issued when the CMFV5 bit in TSR_5 is set to 1. 0: Interrupt requests (TGIV_5) disabled 1: Interrupt requests (TGIV_5) enabled
0	TGIE5W	0	R/W	TGR Interrupt Enable 5W Enables or disables interrupt requests (TGIW_5) issued when the CMFW5 bit in TSR_5 is set to 1. 0: Interrupt requests (TGIW_5) disabled 1: Interrupt requests (TGIW_5) enabled

### 9.3.6 Timer Status Register (TSR)

The TSR registers are 8-bit readable/writable registers that indicate the status of each channel. The MTU2 has seven TSR registers, two for channel 0 and one each for channels 1 to 5.

- TSR\_0, TSR\_1, TSR\_2, TSR\_3, TSR\_4

Bit:	7	6	5	4	3	2	1	0
	TCFD	-	TCFU	TCFV	TGFD	TGFC	TGFB	TGFA
Initial value:	1	1	0	0	0	0	0	0
R/W:	R	R	R/(W)*1	R/(W)*1	R/(W)*1	R/(W)*1	R/(W)*1	R/(W)*1

Note: 1. Writing 0 to this bit after reading it as 1 clears the flag and is the only allowed way.

Bit	Bit Name	Initial Value	R/W	Description
7	TCFD	1	R	Count Direction Flag Status flag that shows the direction in which TCNT counts in channels 1 to 4. In channel 0, bit 7 is reserved. It is always read as 1 and the write value should always be 1. 0: TCNT counts down 1: TCNT counts up
6	—	1	R	Reserved This bit is always read as 1. The write value should always be 1.
5	TCFU	0	R/(W)*1	Underflow Flag Status flag that indicates that TCNT underflow has occurred when channels 1 and 2 are set to phase counting mode. Only 0 can be written, for flag clearing. In channels 0, 3, and 4, bit 5 is reserved. It is always read as 0 and the write value should always be 0. [Setting condition] <ul style="list-style-type: none"> <li>• When the TCNT value underflows (changes from H'0000 to H'FFFF)</li> </ul> [Clearing condition] <ul style="list-style-type: none"> <li>• When 0 is written to TCFU after reading TCFU = 1*2</li> </ul>

Bit	Bit Name	Initial Value	R/W	Description
4	TCFV	0	R/(W)* <sup>1</sup>	<p>Overflow Flag</p> <p>Status flag that indicates that TCNT overflow has occurred. Only 0 can be written, for flag clearing.</p> <p>[Setting condition]</p> <ul style="list-style-type: none"> <li>When the TCNT value overflows (changes from H'FFFF to H'0000) In channel 4, when the TCNT_4 value underflows (changes from H'0001 to H'0000) in complementary PWM mode, this flag is also set.</li> </ul> <p>[Clearing condition]</p> <ul style="list-style-type: none"> <li>When 0 is written to TCFV after reading TCFV = 1*<sup>2</sup></li> </ul>
3	TGFD	0	R/(W)* <sup>1</sup>	<p>Input Capture/Output Compare Flag D</p> <p>Status flag that indicates the occurrence of TGRD input capture or compare match in channels 0, 3, and 4. Only 0 can be written, for flag clearing. In channels 1 and 2, bit 3 is reserved. It is always read as 0 and the write value should always be 0.</p> <p>[Setting conditions]</p> <ul style="list-style-type: none"> <li>When TCNT = TGRD and TGRD is functioning as output compare register</li> <li>When TCNT value is transferred to TGRD by input capture signal and TGRD is functioning as input capture register</li> </ul> <p>[Clearing condition]</p> <ul style="list-style-type: none"> <li>When 0 is written to TGFD after reading TGFD = 1*<sup>2</sup></li> </ul>

Bit	Bit Name	Initial Value	R/W	Description
2	TGFC	0	R/(W)* <sup>1</sup>	<p>Input Capture/Output Compare Flag C</p> <p>Status flag that indicates the occurrence of TGRC input capture or compare match in channels 0, 3, and 4. Only 0 can be written, for flag clearing. In channels 1 and 2, bit 2 is reserved. It is always read as 0 and the write value should always be 0.</p> <p>[Setting conditions]</p> <ul style="list-style-type: none"> <li>• When TCNT = TGRC and TGRC is functioning as output compare register</li> <li>• When TCNT value is transferred to TGRC by input capture signal and TGRC is functioning as input capture register</li> </ul> <p>[Clearing condition]</p> <ul style="list-style-type: none"> <li>• When 0 is written to TGFC after reading TGFC = 1*<sup>2</sup></li> </ul>
1	TGFB	0	R/(W)* <sup>1</sup>	<p>Input Capture/Output Compare Flag B</p> <p>Status flag that indicates the occurrence of TGRB input capture or compare match. Only 0 can be written, for flag clearing.</p> <p>[Setting conditions]</p> <ul style="list-style-type: none"> <li>• When TCNT = TGRB and TGRB is functioning as output compare register</li> <li>• When TCNT value is transferred to TGRB by input capture signal and TGRB is functioning as input capture register</li> </ul> <p>[Clearing condition]</p> <ul style="list-style-type: none"> <li>• When 0 is written to TGFB after reading TGFB = 1*<sup>2</sup></li> </ul>



Bit	Bit Name	Initial Value	R/W	Description
0	TGFA	0	R/(W)* <sup>1</sup>	<p>Input Capture/Output Compare Flag A</p> <p>Status flag that indicates the occurrence of TGRA input capture or compare match. Only 0 can be written, for flag clearing.</p> <p>[Setting conditions]</p> <ul style="list-style-type: none"> <li>• When TCNT = TGRA and TGRA is functioning as output compare register</li> <li>• When TCNT value is transferred to TGRA by input capture signal and TGRA is functioning as input capture register</li> </ul> <p>[Clearing condition]</p> <ul style="list-style-type: none"> <li>• When 0 is written to TGFA after reading TGFA = 1*<sup>2</sup></li> </ul>

- Notes:
1. Writing 0 to this bit after reading it as 1 clears the flag and is the only allowed way.
  2. If another flag setting condition occurs before writing 0 to the bit after reading it as 1, the flag will not be cleared by writing 0 to it once. In this case, read the bit as 1 again and write 0 to it.

## • TSR2\_0

Bit:	7	6	5	4	3	2	1	0
	-	-	-	-	-	-	TGFF	TGFE
Initial value:	1	1	0	0	0	0	0	0
R/W:	R	R	R	R	R	R	R/(W)* <sup>1</sup>	R/(W)* <sup>1</sup>

Note: 1. Writing 0 to this bit after reading it as 1 clears the flag and is the only allowed way.

Bit	Bit Name	Initial Value	R/W	Description
7, 6	—	All 1	R	Reserved These bits are always read as 1. The write value should always be 1.
5 to 2	—	All 0	R	Reserved These bits are always read as 0. The write value should always be 0.
1	TGFF	0	R/(W)* <sup>1</sup>	Compare Match Flag F Status flag that indicates the occurrence of compare match between TCNT_0 and TGRF_0. [Setting condition] <ul style="list-style-type: none"> <li>• When TCNT_0 = TGRF_0 and TGRF_0 is functioning as compare register</li> </ul> [Clearing condition] <ul style="list-style-type: none"> <li>• When 0 is written to TGFF after reading TGFF = 1*<sup>2</sup></li> </ul>
0	TGFE	0	R/(W)* <sup>1</sup>	Compare Match Flag E Status flag that indicates the occurrence of compare match between TCNT_0 and TGRE_0. [Setting condition] <ul style="list-style-type: none"> <li>• When TCNT_0 = TGRE_0 and TGRE_0 is functioning as compare register</li> </ul> [Clearing condition] <ul style="list-style-type: none"> <li>• When 0 is written to TGFE after reading TGFE = 1*<sup>2</sup></li> </ul>

Notes: 1. Writing 0 to this bit after reading it as 1 clears the flag and is the only allowed way.  
2. If another flag setting condition occurs before writing 0 to the bit after reading it as 1, the flag will not be cleared by writing 0 to it once. In this case, read the bit as 1 again and write 0 to it.

- TSR\_5

Bit:	7	6	5	4	3	2	1	0
	-	-	-	-	-	CMFU5	CMFV5	CMFW5
Initial value:	0	0	0	0	0	0	0	0
R/W:	R	R	R	R	R	R/(W)* <sup>1</sup>	R/(W)* <sup>1</sup>	R/(W)* <sup>1</sup>

Note: 1. Writing 0 to this bit after reading it as 1 clears the flag and is the only allowed way.

Bit	Bit Name	Initial Value	R/W	Description
7 to 3	—	All 0	R	Reserved  These bits are always read as 0. The write value should always be 0.
2	CMFU5	0	R/(W)* <sup>1</sup>	Compare Match/Input Capture Flag U5  Status flag that indicates the occurrence of TGRU_5 input capture or compare match.  [Setting conditions] <ul style="list-style-type: none"> <li>When TCNTU_5 = TGRU_5 and TGRU_5 is functioning as output compare register</li> <li>When TCNTU_5 value is transferred to TGRU_5 by input capture signal and TGRU_5 is functioning as input capture register</li> <li>When TCNTU_5 value is transferred to TGRU_5 and TGRU_5 is functioning as a register for measuring the pulse width of the external input signal. The transfer timing is specified by the IOC bits in timer I/O control register U_5 (TIORU_5)*<sup>2</sup></li> </ul> [Clearing condition] <ul style="list-style-type: none"> <li>When 0 is written to CMFU5 after reading CMFU5 = 1</li> </ul>

Bit	Bit Name	Initial Value	R/W	Description
1	CMFV5	0	R/(W)* <sup>1</sup>	<p>Compare Match/Input Capture Flag V5</p> <p>Status flag that indicates the occurrence of TGRV_5 input capture or compare match.</p> <p>[Setting conditions]</p> <ul style="list-style-type: none"> <li>• When TCNTV_5 = TGRV_5 and TGRV_5 is functioning as output compare register</li> <li>• When TCNTV_5 value is transferred to TGRV_5 by input capture signal and TGRV_5 is functioning as input capture register</li> <li>• When TCNTV_5 value is transferred to TGRV_5 and TGRV_5 is functioning as a register for measuring the pulse width of the external input signal. The transfer timing is specified by the IOC bits in timer I/O control register V_5 (TIORV_5)*<sup>2</sup></li> </ul> <p>[Clearing condition]</p> <ul style="list-style-type: none"> <li>• When 0 is written to CMFV5 after reading CMFV5 = 1</li> </ul>

Bit	Bit Name	Initial Value	R/W	Description
0	CMFW5	0	R/(W)* <sup>1</sup>	<p>Compare Match/Input Capture Flag W5</p> <p>Status flag that indicates the occurrence of TGRW_5 input capture or compare match.</p> <p>[Setting conditions]</p> <ul style="list-style-type: none"> <li>• When TCNTW_5 = TGRW_5 and TGRW_5 is functioning as output compare register</li> <li>• When TCNTW_5 value is transferred to TGRW_5 by input capture signal and TGRW_5 is functioning as input capture register</li> <li>• When TCNTW_5 value is transferred to TGRW_5 and TGRW_5 is functioning as a register for measuring the pulse width of the external input signal. The transfer timing is specified by the IOC bits in timer I/O control register W_5 (TIORW_5)*<sup>2</sup></li> </ul> <p>[Clearing condition]</p> <ul style="list-style-type: none"> <li>• When 0 is written to CMFW5 after reading CMFW5 = 1</li> </ul>

- Notes: 1 Writing 0 to this bit after reading it as 1 clears the flag and is the only allowed way.
2. The transfer timing is specified by the IOC bit in the timer I/O control register U\_5/V\_5/W\_5 (TIORU\_5, TIORV\_5, TIORW\_5).

### 9.3.7 Timer Buffer Operation Transfer Mode Register (TBTM)

The TBTM registers are 8-bit readable/writable registers that specify the timing for transferring data from the buffer register to the timer general register in PWM mode. The MTU2 has three TBTM registers, one each for channels 0, 3, and 4.

Bit:	7	6	5	4	3	2	1	0
	-	-	-	-	-	TTSE	TTSB	TTSA
Initial value:	0	0	0	0	0	0	0	0
R/W:	R	R	R	R	R	R/W	R/W	R/W

Bit	Bit Name	Initial Value	R/W	Description
7 to 3	—	All 0	R	Reserved  These bits are always read as 0. The write value should always be 0.
2	TTSE	0	R/W	Timing Select E  Specifies the timing for transferring data from TGRF_0 to TGRE_0 when they are used together for buffer operation.  In channels 3 and 4, bit 2 is reserved. It is always read as 0 and the write value should always be 0. When using channel 0 in other than PWM mode, do not set this bit to 1.  0: When compare match E occurs in channel 0 1: When TCNT_0 is cleared
1	TTSB	0	R/W	Timing Select B  Specifies the timing for transferring data from TGRD to TGRB in each channel when they are used together for buffer operation. When using channel 0 in other than PWM mode, do not set this bit to 1.  0: When compare match B occurs in each channel 1: When TCNT is cleared in each channel

Bit	Bit Name	Initial Value	R/W	Description
0	TTSA	0	R/W	Timing Select A Specifies the timing for transferring data from TGRC to TGRA in each channel when they are used together for buffer operation. When using channel 0 in other than PWM mode, do not set this bit to 1. 0: When compare match A occurs in each channel 1: When TCNT is cleared in each channel

### 9.3.8 Timer Input Capture Control Register (TICCR)

TICCR is an 8-bit readable/writable register that specifies input capture conditions when TCNT\_1 and TCNT\_2 are cascaded. The MTU2 has one TICCR in channel 1.

Bit:	7	6	5	4	3	2	1	0
	-	-	-	-	I2BE	I2AE	I1BE	I1AE
Initial value:	0	0	0	0	0	0	0	0
R/W:	R	R	R	R	R/W	R/W	R/W	R/W

Bit	Bit Name	Initial Value	R/W	Description
7 to 4	—	All 0	R	Reserved These bits are always read as 0. The write value should always be 0.
3	I2BE	0	R/W	Input Capture Enable Specifies whether to include the TIOC2B pin in the TGRB_1 input capture conditions. 0: Does not include the TIOC2B pin in the TGRB_1 input capture conditions 1: Includes the TIOC2B pin in the TGRB_1 input capture conditions

Bit	Bit Name	Initial Value	R/W	Description
2	I2AE	0	R/W	<p>Input Capture Enable</p> <p>Specifies whether to include the TIOC2A pin in the TGRA_1 input capture conditions.</p> <p>0: Does not include the TIOC2A pin in the TGRA_1 input capture conditions</p> <p>1: Includes the TIOC2A pin in the TGRA_1 input capture conditions</p>
1	I1BE	0	R/W	<p>Input Capture Enable</p> <p>Specifies whether to include the TIOC1B pin in the TGRB_2 input capture conditions.</p> <p>0: Does not include the TIOC1B pin in the TGRB_2 input capture conditions</p> <p>1: Includes the TIOC1B pin in the TGRB_2 input capture conditions</p>
0	I1AE	0	R/W	<p>Input Capture Enable</p> <p>Specifies whether to include the TIOC1A pin in the TGRA_2 input capture conditions.</p> <p>0: Does not include the TIOC1A pin in the TGRA_2 input capture conditions</p> <p>1: Includes the TIOC1A pin in the TGRA_2 input capture conditions</p>

Note: This function is supported only by the SH7125. In the SH7124, write value should always be H'00.



### 9.3.9 Timer A/D Converter Start Request Control Register (TADCR)

TADCR is a 16-bit readable/writable register that enables or disables A/D converter start requests and specifies whether to link A/D converter start requests with interrupt skipping operation. The MTU2 has one TADCR in channel 4.

Bit:	15	14	13	12	11	10	9	8	7	6	5	4	3	2	1	0
	BF[1:0]		-	-	-	-	-	-	UT4AE	DT4AE	UT4BE	DT4BE	ITA3AE	ITA4VE	ITB3AE	ITB4VE
Initial value:	0	0	0	0	0	0	0	0	0	0*	0	0*	0*	0*	0*	0*
R/W:	R/W	R/W	R	R	R	R	R	R	R/W	R/W	R/W	R/W	R/W	R/W	R/W	R/W

Note: \* Do not set to 1 when complementary PWM mode is not selected.

Bit	Bit Name	Initial Value	R/W	Description
15, 14	BF[1:0]	00	R/W	TADCOBRA_4/TADCOBRB_4 Transfer Timing Select Select the timing for transferring data from TADCOBRA_4 and TADCOBRB_4 to TADCORA_4 and TADCORB_4. For details, see table 9.29.
13 to 8	—	All 0	R	Reserved These bits are always read as 0. The write value should always be 0.
7	UT4AE	0	R/W	Up-Count TRG4AN Enable Enables or disables A/D converter start requests (TRG4AN) during TCNT_4 up-count operation. 0: A/D converter start requests (TRG4AN) disabled during TCNT_4 up-count operation 1: A/D converter start requests (TRG4AN) enabled during TCNT_4 up-count operation
6	DT4AE	0*	R/W	Down-Count TRG4AN Enable Enables or disables A/D converter start requests (TRG4AN) during TCNT_4 down-count operation. 0: A/D converter start requests (TRG4AN) disabled during TCNT_4 down-count operation 1: A/D converter start requests (TRG4AN) enabled during TCNT_4 down-count operation

Bit	Bit Name	Initial Value	R/W	Description
5	UT4BE	0	R/W	<p>Up-Count TRG4BN Enable</p> <p>Enables or disables A/D converter start requests (TRG4BN) during TCNT_4 up-count operation.</p> <p>0: A/D converter start requests (TRG4BN) disabled during TCNT_4 up-count operation</p> <p>1: A/D converter start requests (TRG4BN) enabled during TCNT_4 up-count operation</p>
4	DT4BE	0*	R/W	<p>Down-Count TRG4BN Enable</p> <p>Enables or disables A/D converter start requests (TRG4BN) during TCNT_4 down-count operation.</p> <p>0: A/D converter start requests (TRG4BN) disabled during TCNT_4 down-count operation</p> <p>1: A/D converter start requests (TRG4BN) enabled during TCNT_4 down-count operation</p>
3	ITA3AE	0*	R/W	<p>TGIA_3 Interrupt Skipping Link Enable</p> <p>Select whether to link A/D converter start requests (TRG4AN) with TGIA_3 interrupt skipping operation.</p> <p>0: Does not link with TGIA_3 interrupt skipping</p> <p>1: Links with TGIA_3 interrupt skipping</p>
2	ITA4VE	0*	R/W	<p>TCIV_4 Interrupt Skipping Link Enable</p> <p>Select whether to link A/D converter start requests (TRG4AN) with TCIV_4 interrupt skipping operation.</p> <p>0: Does not link with TCIV_4 interrupt skipping</p> <p>1: Links with TCIV_4 interrupt skipping</p>
1	ITB3AE	0*	R/W	<p>TGIA_3 Interrupt Skipping Link Enable</p> <p>Select whether to link A/D converter start requests (TRG4BN) with TGIA_3 interrupt skipping operation.</p> <p>0: Does not link with TGIA_3 interrupt skipping</p> <p>1: Links with TGIA_3 interrupt skipping</p>

Bit	Bit Name	Initial Value	R/W	Description
0	ITB4VE	0*	R/W	TCIV_4 Interrupt Skipping Link Enable Select whether to link A/D converter start requests (TRG4BN) with TCIV_4 interrupt skipping operation. 0: Does not link with TCIV_4 interrupt skipping 1: Links with TCIV_4 interrupt skipping

- Notes:
1. TADCR must not be accessed in eight bits; it should always be accessed in 16 bits.
  2. When interrupt skipping is disabled (the T3AEN and T4VEN bits in the timer interrupt skipping set register (TITCR) are cleared to 0 or the skipping count set bits (3ACOR and 4VCOR) in TITCR are cleared to 0), do not link A/D converter start requests with interrupt skipping operation (clear the ITA3AE, ITA4VE, ITB3AE, and ITB4VE bits in the timer A/D converter start request control register (TADCR) to 0).
  3. If link with interrupt skipping is enabled while interrupt skipping is disabled, A/D converter start requests will not be issued.
- \* Do not set to 1 when complementary PWM mode is not selected.

**Table 9.29 Setting of Transfer Timing by BF1 and BF0 Bits**

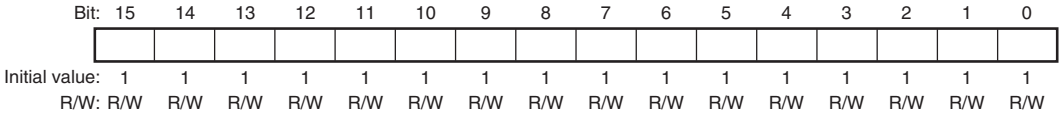
Bit 7	Bit 6	Description
BF1	BF0	
0	0	Does not transfer data from the cycle set buffer register to the cycle set register.
0	1	Transfers data from the cycle set buffer register to the cycle set register at the crest of the TCNT_4 count.* <sup>1</sup>
1	0	Transfers data from the cycle set buffer register to the cycle set register at the trough of the TCNT_4 count.* <sup>2</sup>
1	1	Transfers data from the cycle set buffer register to the cycle set register at the crest and trough of the TCNT_4 count.* <sup>2</sup>

- Notes:
1. Data is transferred from the cycle set buffer register to the cycle set register when the crest of the TCNT\_4 count is reached in complementary PWM mode, when compare match occurs between TCNT\_3 and TGRA\_3 in reset-synchronized PWM mode, or when compare match occurs between TCNT\_4 and TGRA\_4 in PWM mode 1 or normal operation mode.
  2. These settings are prohibited when complementary PWM mode is not selected.

### 9.3.10 Timer A/D Converter Start Request Cycle Set Registers (TADCORA\_4 and TADCORB\_4)

TADCORA\_4 and TADCORB\_4 are 16-bit readable/writable registers. When the TCNT\_4 count reaches the value in TADCORA\_4 or TADCORB\_4, a corresponding A/D converter start request will be issued.

TADCORA\_4 and TADCORB\_4 are initialized to H'FFFF.

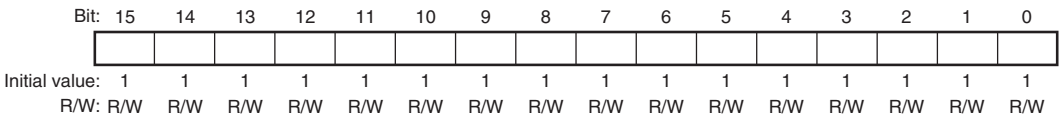


Note: TADCORA\_4 and TADCORB\_4 must not be accessed in eight bits; they should always be accessed in 16 bits.

### 9.3.11 Timer A/D Converter Start Request Cycle Set Buffer Registers (TADCOBRA\_4 and TADCOBRB\_4)

TADCOBRA\_4 and TADCOBRB\_4 are 16-bit readable/writable registers. When the crest or trough of the TCNT\_4 count is reached, these register values are transferred to TADCORA\_4 and TADCORB\_4, respectively.

TADCOBRA\_4 and TADCOBRB\_4 are initialized to H'FFFF.



Note: TADCOBRA\_4 and TADCOBRB\_4 must not be accessed in eight bits; they should always be accessed in 16 bits.

### 9.3.12 Timer Counter (TCNT)

The TCNT counters are 16-bit readable/writable counters. The MTU2 has eight TCNT counters, one each for channels 0 to 4 and three (TCNTU\_5, TCNTV\_5, and TCNTW\_5) for channel 5.

The TCNT counters are initialized to H'0000 by a reset.



Note: The TCNT counters must not be accessed in eight bits; they should always be accessed in 16 bits.

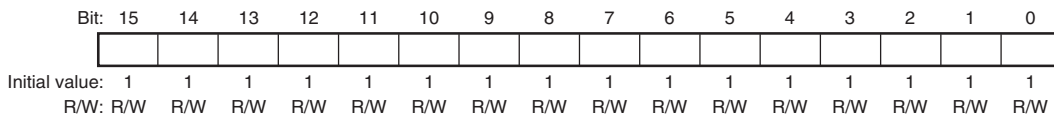
### 9.3.13 Timer General Register (TGR)

The TGR registers are 16-bit readable/writable registers. The MTU2 has 21 TGR registers, six for channel 0, two each for channels 1 and 2, four each for channels 3 and 4, and three for channel 5.

TGRA, TGRB, TGRC, and TGRD function as either output compare or input capture registers. TGRC and TGRD for channels 0, 3, and 4 can also be designated for operation as buffer registers. TGR buffer register combinations are TGRA and TGRC, and TGRB and TGRD.

TGRE\_0 and TGRF\_0 function as compare registers. When the TCNT\_0 count matches the TGRE\_0 value, an A/D converter start request can be issued. TGRF can also be designated for operation as a buffer register. TGR buffer register combination is TGRE and TGRF.

TGRU\_5, TGRV\_5, and TGRW\_5 function as compare match, input capture, or external pulse width measurement registers.



Note: The TGR registers must not be accessed in eight bits; they should always be accessed in 16 bits. TGR registers are initialized to H'FFFF.

### 9.3.14 Timer Start Register (TSTR)

TSTR is an 8-bit readable/writable register that selects operation/stoppage of TCNT for channels 0 to 4.

TSTR\_5 is an 8-bit readable/writable register that selects operation/stoppage of TCNTU\_5, TCNTV\_5, and TCNTW\_5 for channel 5.

When setting the operating mode in TMDR or setting the count clock in TCR, first stop the TCNT counter.

- TSTR

Bit:	7	6	5	4	3	2	1	0
	CST4	CST3	-	-	-	CST2	CST1	CST0
Initial value:	0	0	0	0	0	0	0	0
R/W:	R/W	R/W	R	R	R	R/W	R/W	R/W

Bit	Bit Name	Initial Value	R/W	Description
7	CST4	0	R/W	Counter Start 4 and 3
6	CST3	0	R/W	<p>These bits select operation or stoppage for TCNT.</p> <p>If 0 is written to the CST bit during operation with the TIOC pin designated for output, the counter stops but the TIOC pin output compare output level is retained. If TIOR is written to when the CST bit is cleared to 0, the pin output level will be changed to the set initial output value.</p> <p>0: TCNT_4 and TCNT_3 count operation is stopped</p> <p>1: TCNT_4 and TCNT_3 performs count operation</p>
5 to 3	—	All 0	R	<p>Reserved</p> <p>These bits are always read as 0. The write value should always be 0.</p>

Bit	Bit Name	Initial Value	R/W	Description
2	CST2	0	R/W	Counter Start 2 to 0
1	CST1	0	R/W	These bits select operation or stoppage for TCNT.
0	CST0	0	R/W	If 0 is written to the CST bit during operation with the TIOC pin designated for output, the counter stops but the TIOC pin output compare output level is retained. If TIOR is written to when the CST bit is cleared to 0, the pin output level will be changed to the set initial output value.  0: TCNT_2 to TCNT_0 count operation is stopped 1: TCNT_2 to TCNT_0 performs count operation

- TSTR\_5

Bit:	7	6	5	4	3	2	1	0
	-	-	-	-	-	CSTU5	CSTV5	CSTW5
Initial value:	0	0	0	0	0	0	0	0
R/W:	R	R	R	R	R	R/W	R/W	R/W

Bit	Bit Name	Initial Value	R/W	Description
7 to 3	—	All 0	R	Reserved  These bits are always read as 0. The write value should always be 0.
2	CSTU5	0	R/W	Counter Start U5 Selects operation or stoppage for TCNTU_5. 0: TCNTU_5 count operation is stopped 1: TCNTU_5 performs count operation
1	CSTV5	0	R/W	Counter Start V5 Selects operation or stoppage for TCNTV_5. 0: TCNTV_5 count operation is stopped 1: TCNTV_5 performs count operation
0	CSTW5	0	R/W	Counter Start W5 Selects operation or stoppage for TCNTW_5. 0: TCNTW_5 count operation is stopped 1: TCNTW_5 performs count operation

### 9.3.15 Timer Synchronous Register (TSYR)

TSYR is an 8-bit readable/writable register that selects independent operation or synchronous operation for the channel 0 to 4 TCNT counters. A channel performs synchronous operation when the corresponding bit in TSYR is set to 1.

Bit:	7	6	5	4	3	2	1	0
	SYNC4	SYNC3	-	-	-	SYNC2	SYNC1	SYNC0
Initial value:	0	0	0	0	0	0	0	0
R/W:	R/W	R/W	R	R	R	R/W	R/W	R/W

Bit	Bit Name	Initial Value	R/W	Description
7	SYNC4	0	R/W	Timer Synchronous operation 4 and 3
6	SYNC3	0	R/W	<p>These bits are used to select whether operation is independent of or synchronized with other channels.</p> <p>When synchronous operation is selected, the TCNT synchronous presetting of multiple channels, and synchronous clearing by counter clearing on another channel, are possible.</p> <p>To set synchronous operation, the SYNC bits for at least two channels must be set to 1. To set synchronous clearing, in addition to the SYNC bit, the TCNT clearing source must also be set by means of bits CCLR0 to CCLR2 in TCR.</p> <p>0: TCNT_4 and TCNT_3 operate independently (TCNT presetting/clearing is unrelated to other channels)</p> <p>1: TCNT_4 and TCNT_3 performs synchronous operation TCNT synchronous presetting/synchronous clearing is possible</p>
5 to 3	—	All 0	R	<p>Reserved</p> <p>These bits are always read as 0. The write value should always be 0.</p>



Bit	Bit Name	Initial Value	R/W	Description
2	SYNC2	0	R/W	Timer Synchronous operation 2 to 0
1	SYNC1	0	R/W	These bits are used to select whether operation is independent of or synchronized with other channels. When synchronous operation is selected, the TCNT synchronous presetting of multiple channels, and synchronous clearing by counter clearing on another channel, are possible.
0	SYNC0	0	R/W	

To set synchronous operation, the SYNC bits for at least two channels must be set to 1. To set synchronous clearing, in addition to the SYNC bit, the TCNT clearing source must also be set by means of bits CCLR0 to CCLR2 in TCR.

0: TCNT\_2 to TCNT\_0 operates independently (TCNT presetting /clearing is unrelated to other channels)

1: TCNT\_2 to TCNT\_0 performs synchronous operation  
TCNT synchronous presetting/synchronous clearing is possible

### 9.3.16 Timer Read/Write Enable Register (TRWER)

TRWER is an 8-bit readable/writable register that enables or disables access to the registers and counters which have write-protection capability against accidental modification in channels 3 and 4.

Bit:	7	6	5	4	3	2	1	0
	-	-	-	-	-	-	-	RWE
Initial value:	0	0	0	0	0	0	0	1
R/W:	R	R	R	R	R	R	R	R/W

Bit	Bit Name	Initial Value	R/W	Description
7 to 1	—	All 0	R	Reserved  These bits are always read as 0. The write value should always be 0.
0	RWE	1	R/W	Read/Write Enable  Enables or disables access to the registers which have write-protection capability against accidental modification.  0: Disables read/write access to the registers 1: Enables read/write access to the registers [Clearing condition] <ul style="list-style-type: none"> <li>• When 0 is written to the RWE bit after reading RWE = 1</li> </ul>

- Registers and counters having write-protection capability against accidental modification  
22 registers: TCR\_3, TCR\_4, TMDR\_3, TMDR\_4, TIORH\_3, TIORH\_4, TIORL\_3, TIORL\_4, TIER\_3, TIER\_4, TGRA\_3, TGRA\_4, TGRB\_3, TGRB\_4, TOER, TOCR1, TOCR2, TGCR, TCDR, TDDR, TCNT\_3, and TCNT\_4.

### 9.3.17 Timer Output Master Enable Register (TOER)

TOER is an 8-bit readable/writable register that enables/disables output settings for output pins TIOC4D, TIOC4C, TIOC3D, TIOC4B, TIOC4A, and TIOC3B. These pins do not output correctly if the TOER bits have not been set. Set TOER of channel 3 and channel 4 prior to setting TIOR of channel 3 and channel 4.

Bit:	7	6	5	4	3	2	1	0
	-	-	OE4D	OE4C	OE3D	OE4B	OE4A	OE3B
Initial value:	1	1	0	0	0	0	0	0
R/W:	R	R	R/W	R/W	R/W	R/W	R/W	R/W

Bit	Bit Name	Initial Value	R/W	Description
7, 6	—	All 1	R	Reserved These bits are always read as 1. The write value should always be 1.
5	OE4D	0	R/W	Master Enable TIOC4D This bit enables/disables the TIOC4D pin MTU2 output. 0: MTU2 output is disabled (inactive level)* 1: MTU2 output is enabled
4	OE4C	0	R/W	Master Enable TIOC4C This bit enables/disables the TIOC4C pin MTU2 output. 0: MTU2 output is disabled (inactive level)* 1: MTU2 output is enabled
3	OE3D	0	R/W	Master Enable TIOC3D This bit enables/disables the TIOC3D pin MTU2 output. 0: MTU2 output is disabled (inactive level)* 1: MTU2 output is enabled
2	OE4B	0	R/W	Master Enable TIOC4B This bit enables/disables the TIOC4B pin MTU2 output. 0: MTU2 output is disabled (inactive level)* 1: MTU2 output is enabled
1	OE4A	0	R/W	Master Enable TIOC4A This bit enables/disables the TIOC4A pin MTU2 output. 0: MTU2 output is disabled (inactive level)* 1: MTU2 output is enabled

Bit	Bit Name	Initial Value	R/W	Description
0	OE3B	0	R/W	Master Enable TIOC3B This bit enables/disables the TIOC3B pin MTU2 output. 0: MTU2 output is disabled (inactive level)* 1: MTU2 output is enabled

Note: \* The inactive level is determined by the settings in timer output control registers 1 and 2 (TOCR1 and TOCR2). For details, refer to section 9.3.18, Timer Output Control Register 1 (TOCR1), and section 9.3.19, Timer Output Control Register 2 (TOCR2). Set these bits to 1 to enable MTU2 output in other than complementary PWM or reset-synchronized PWM mode. When these bits are set to 0, low level is output.

### 9.3.18 Timer Output Control Register 1 (TOCR1)

TOCR1 is an 8-bit readable/writable register that enables/disables PWM synchronized toggle output in complementary PWM mode/reset synchronized PWM mode, and controls output level inversion of PWM output.

Bit:	7	6	5	4	3	2	1	0
	-	PSYE	-	-	TOCL	TOCS	OLSN	OLSP
Initial value:	0	0	0	0	0	0	0	0
R/W:	R	R/W	R	R	R/(W)*	R/W	R/W	R/W

Note: \* This bit can be set to 1 only once after a power-on reset. After 1 is written, 0 cannot be written to the bit.

Bit	Bit Name	Initial value	R/W	Description
7	—	0	R	Reserved This bit is always read as 0. The write value should always be 0.
6	PSYE	0	R/W	PWM Synchronous Output Enable This bit selects the enable/disable of toggle output synchronized with the PWM period. 0: Toggle output is disabled 1: Toggle output is enabled
5, 4	—	All 0	R	Reserved These bits are always read as 0. The write value should always be 0.

Bit	Bit Name	Initial Value	R/W	Description
3	TOCL	0	R/(W)* <sup>1</sup>	<p>TOC Register Write Protection*<sup>2</sup></p> <p>This bit selects the enable/disable of write access to the TOCS, OLSN, and OLSP bits in TOCR1.</p> <p>0: Write access to the TOCS, OLSN, and OLSP bits is enabled</p> <p>1: Write access to the TOCS, OLSN, and OLSP bits is disabled</p>
2	TOCS	0	R/W	<p>TOC Select</p> <p>This bit selects either the TOCR1 or TOCR2 setting to be used for the output level in complementary PWM mode and reset-synchronized PWM mode.</p> <p>0: TOCR1 setting is selected</p> <p>1: TOCR2 setting is selected</p>
1	OLSN	0	R/W	<p>Output Level Select N*<sup>3</sup></p> <p>This bit selects the reverse phase output level in reset-synchronized PWM mode/complementary PWM mode. See table 9.30.</p>
0	OLSP	0	R/W	<p>Output Level Select P*<sup>3</sup></p> <p>This bit selects the positive phase output level in reset-synchronized PWM mode/complementary PWM mode. See table 9.31.</p>

- Notes:
1. This bit can be set to 1 only once after a power on reset. After 1 is written, 0 cannot be written to the bit.
  2. Setting the TOCL bit to 1 prevents accidental modification when the CPU goes out of control.
  3. Clearing the TOCS bit to 0 makes this bit setting valid.

**Table 9.30 Output Level Select Function**

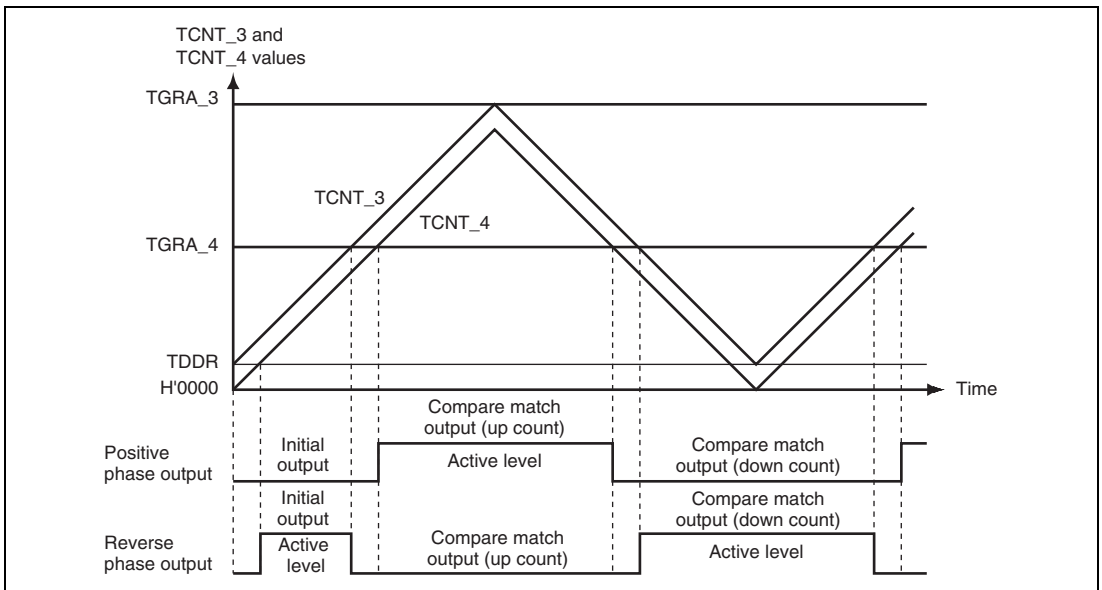
Bit 1		Function		
OLSN	Initial Output	Active Level	Compare Match Output	
			Up Count	Down Count
0	High level	Low level	High level	Low level
1	Low level	High level	Low level	High level

Note: The reverse phase waveform initial output value changes to active level after elapse of the dead time after count start.

**Table 9.31 Output Level Select Function**

Bit 0	Function			
	OLSP	Initial Output	Active Level	Compare Match Output
Up Count				Down Count
0	High level	Low level	Low level	High level
1	Low level	High level	High level	Low level

Figure 9.2 shows an example of complementary PWM mode output (1 phase) when OLSN = 1 and OLSP = 1.

**Figure 9.2 Complementary PWM Mode Output Level Example**

### 9.3.19 Timer Output Control Register 2 (TOCR2)

TOCR2 is an 8-bit readable/writable register that controls output level inversion of PWM output in complementary PWM mode and reset-synchronized PWM mode.

Bit:	7	6	5	4	3	2	1	0
	BF[1:0]	OLS3N	OLS3P	OLS2N	OLS2P	OLS1N	OLS1P	
Initial value:	0	0	0	0	0	0	0	0
R/W:	R/W	R/W	R/W	R/W	R/W	R/W	R/W	R/W

Bit	Bit Name	Initial value	R/W	Description
7, 6	BF[1:0]	00	R/W	TOLBR Buffer Transfer Timing Select  These bits select the timing for transferring data from TOLBR to TOCR2.  For details, see table 9.32.
5	OLS3N	0	R/W	Output Level Select 3N*  This bit selects the output level on TIOC4D in reset-synchronized PWM mode/complementary PWM mode. See table 9.33.
4	OLS3P	0	R/W	Output Level Select 3P*  This bit selects the output level on TIOC4B in reset-synchronized PWM mode/complementary PWM mode. See table 9.34.
3	OLS2N	0	R/W	Output Level Select 2N*  This bit selects the output level on TIOC4C in reset-synchronized PWM mode/complementary PWM mode. See table 9.35.
2	OLS2P	0	R/W	Output Level Select 2P*  This bit selects the output level on TIOC4A in reset-synchronized PWM mode/complementary PWM mode. See table 9.36.
1	OLS1N	0	R/W	Output Level Select 1N*  This bit selects the output level on TIOC3D in reset-synchronized PWM mode/complementary PWM mode. See table 9.37.

Bit	Bit Name	Initial value	R/W	Description
0	OLS1P	0	R/W	Output Level Select 1P*  This bit selects the output level on TIOC3B in reset-synchronized PWM mode/complementary PWM mode. See table 9.38.

Note: \* Setting the TOCS bit in TOCR1 to 1 makes this bit setting valid.

**Table 9.32 Setting of Bits BF1 and BF0**

Bit 7	Bit 6	Description	
BF1	BF0	Complementary PWM Mode	Reset-Synchronized PWM Mode
0	0	Does not transfer data from the buffer register (TOLBR) to TOCR2.	Does not transfer data from the buffer register (TOLBR) to TOCR2.
0	1	Transfers data from the buffer register (TOLBR) to TOCR2 at the crest of the TCNT_4 count.	Transfers data from the buffer register (TOLBR) to TOCR2 when TCNT_3/TCNT_4 is cleared
1	0	Transfers data from the buffer register (TOLBR) to TOCR2 at the trough of the TCNT_4 count.	Setting prohibited
1	1	Transfers data from the buffer register (TOLBR) to TOCR2 at the crest and trough of the TCNT_4 count.	Setting prohibited

**Table 9.33 TIOC4D Output Level Select Function**

Bit 5	Function			
OLS3N	Initial Output	Active Level	Compare Match Output	
			Up Count	Down Count
0	High level	Low level	High level	Low level
1	Low level	High level	Low level	High level

Note: The reverse phase waveform initial output value changes to the active level after elapse of the dead time after count start.



**Table 9.34 TIOC4B Output Level Select Function**

Bit 4		Function		
OLS3P	Initial Output	Active Level	Compare Match Output	
			Up Count	Down Count
0	High level	Low level	Low level	High level
1	Low level	High level	High level	Low level

**Table 9.35 TIOC4C Output Level Select Function**

Bit 3		Function		
OLS2N	Initial Output	Active Level	Compare Match Output	
			Up Count	Down Count
0	High level	Low level	High level	Low level
1	Low level	High level	Low level	High level

Note: The reverse phase waveform initial output value changes to the active level after elapse of the dead time after count start.

**Table 9.36 TIOC4A Output Level Select Function**

Bit 2		Function		
OLS2P	Initial Output	Active Level	Compare Match Output	
			Up Count	Down Count
0	High level	Low level	Low level	High level
1	Low level	High level	High level	Low level

**Table 9.37 TIOC3D Output Level Select Function**

Bit 1		Function		
OLS1N	Initial Output	Active Level	Compare Match Output	
			Up Count	Down Count
0	High level	Low level	High level	Low level
1	Low level	High level	Low level	High level

Note: The reverse phase waveform initial output value changes to the active level after elapse of the dead time after count start.

**Table 9.38 TIOC3B Output Level Select Function**

Bit 0		Function		
OLS1P	Initial Output	Active Level	Compare Match Output	
			Up Count	Down Count
0	High level	Low level	Low level	High level
1	Low level	High level	High level	Low level

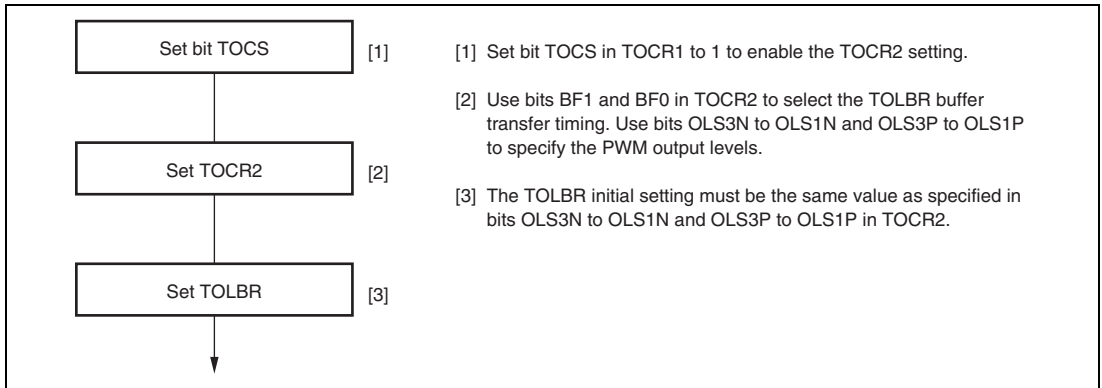
**9.3.20 Timer Output Level Buffer Register (TOLBR)**

TOLBR is an 8-bit readable/writable register that functions as a buffer for TOCR2 and specifies the PWM output level in complementary PWM mode and reset-synchronized PWM mode.

Bit:	7	6	5	4	3	2	1	0
	-	-	OLS3N	OLS3P	OLS2N	OLS2P	OLS1N	OLS1P
Initial value:	0	0	0	0	0	0	0	0
R/W:	R	R	R/W	R/W	R/W	R/W	R/W	R/W

Bit	Bit Name	Initial value	R/W	Description
7, 6	—	All 0	R	Reserved These bits are always read as 0. The write value should always be 0.
5	OLS3N	0	R/W	Specifies the buffer value to be transferred to the OLS3N bit in TOCR2.
4	OLS3P	0	R/W	Specifies the buffer value to be transferred to the OLS3P bit in TOCR2.
3	OLS2N	0	R/W	Specifies the buffer value to be transferred to the OLS2N bit in TOCR2.
2	OLS2P	0	R/W	Specifies the buffer value to be transferred to the OLS2P bit in TOCR2.
1	OLS1N	0	R/W	Specifies the buffer value to be transferred to the OLS1N bit in TOCR2.
0	OLS1P	0	R/W	Specifies the buffer value to be transferred to the OLS1P bit in TOCR2.

Figure 9.3 shows an example of the PWM output level setting procedure in buffer operation.



**Figure 9.3 PWM Output Level Setting Procedure in Buffer Operation**

### 9.3.21 Timer Gate Control Register (TGCR)

TGCR is an 8-bit readable/writable register that controls the waveform output necessary for brushless DC motor control in reset-synchronized PWM mode/complementary PWM mode. These register settings are ineffective for anything other than complementary PWM mode/reset-synchronized PWM mode.

Bit:	7	6	5	4	3	2	1	0
	-	BDC	N	P	FB	WF	VF	UF
Initial value:	1	0	0	0	0	0	0	0
R/W:	R	R/W	R/W	R/W	R/W	R/W	R/W	R/W

Bit	Bit Name	Initial value	R/W	Description
7	—	1	R	Reserved This bit is always read as 1. The write value should always be 1.
6	BDC	0	R/W	Brushless DC Motor This bit selects whether to make the functions of this register (TGCR) effective or ineffective. 0: Ordinary output 1: Functions of this register are made effective

Bit	Bit Name	Initial value	R/W	Description
5	N	0	R/W	<p>Reverse Phase Output (N) Control</p> <p>This bit selects whether the level output or the reset-synchronized PWM/complementary PWM output while the reverse pins (TIOC3D, TIOC4C, and TIOC4D) are output.</p> <p>0: Level output 1: Reset synchronized PWM/complementary PWM output</p>
4	P	0	R/W	<p>Positive Phase Output (P) Control</p> <p>This bit selects whether the level output or the reset-synchronized PWM/complementary PWM output while the positive pin (TIOC3B, TIOC4A, and TIOC4B) are output.</p> <p>0: Level output 1: Reset synchronized PWM/complementary PWM output</p>
3	FB	0	R/W	<p>External Feedback Signal Enable</p> <p>This bit selects whether the switching of the output of the positive/reverse phase is carried out automatically with the MTU2/channel 0 TGRA, TGRB, TGRC input capture signals or by writing 0 or 1 to bits 2 to 0 in TGCR.</p> <p>0: Output switching is external input (Input sources are channel 0 TGRA, TGRB, TGRC input capture signal) 1: Output switching is carried out by software (TGCR's UF, VF, WF settings).</p>
2	WF	0	R/W	Output Phase Switch 2 to 0
1	VF	0	R/W	<p>These bits set the positive phase/negative phase output phase on or off state. The setting of these bits is valid only when the FB bit in this register is set to 1. In this case, the setting of bits 2 to 0 is a substitute for external input. See table 9.39.</p>
0	UF	0	R/W	

**Table 9.39 Output level Select Function**

Bit 2	Bit 1	Bit 0	Function					
			TIOC3B	TIOC4A	TIOC4B	TIOC3D	TIOC4C	TIOC4D
WF	VF	UF	U Phase	V Phase	W Phase	U Phase	V Phase	W Phase
0	0	0	OFF	OFF	OFF	OFF	OFF	OFF
		1	ON	OFF	OFF	OFF	OFF	ON
	1	0	OFF	ON	OFF	ON	OFF	OFF
		1	OFF	ON	OFF	OFF	OFF	ON
1	0	0	OFF	OFF	ON	OFF	ON	OFF
		1	ON	OFF	OFF	OFF	ON	OFF
	1	0	OFF	OFF	ON	ON	OFF	OFF
		1	OFF	OFF	OFF	OFF	OFF	OFF

**9.3.22 Timer Subcounter (TCNTS)**

TCNTS is a 16-bit read-only counter that is used only in complementary PWM mode.

The initial value of TCNTS is H'0000.

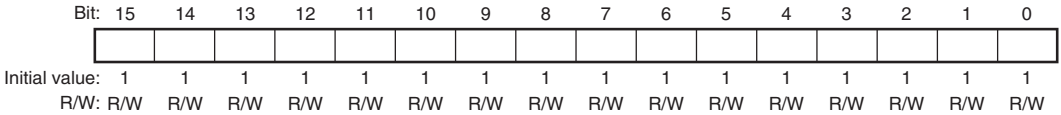
Bit:	15	14	13	12	11	10	9	8	7	6	5	4	3	2	1	0
Initial value:	0	0	0	0	0	0	0	0	0	0	0	0	0	0	0	0
R/W:	R	R	R	R	R	R	R	R	R	R	R	R	R	R	R	R

Note: Accessing the TCNTS in 8-bit units is prohibited. Always access in 16-bit units.

### 9.3.23 Timer Dead Time Data Register (TDDR)

TDDR is a 16-bit register, used only in complementary PWM mode that specifies the TCNT\_3 and TCNT\_4 counter offset values. In complementary PWM mode, when the TCNT\_3 and TCNT\_4 counters are cleared and then restarted, the TDDR register value is loaded into the TCNT\_3 counter and the count operation starts.

The initial value of TDDR is H'FFFF.

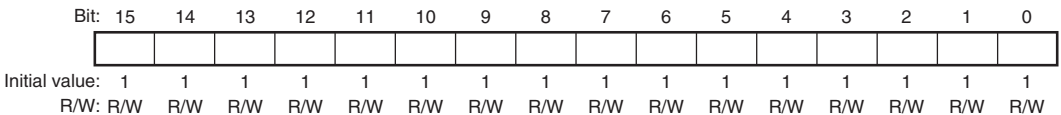


Note: Accessing the TDDR in 8-bit units is prohibited. Always access in 16-bit units.

### 9.3.24 Timer Cycle Data Register (TCDR)

TCDR is a 16-bit register used only in complementary PWM mode. Set half the PWM carrier sync value as the TCDR register value. This register is constantly compared with the TCNTS counter in complementary PWM mode, and when a match occurs, the TCNTS counter switches direction (decrement to increment).

The initial value of TCDR is H'FFFF.

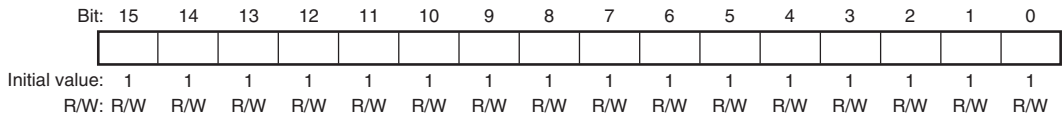


Note: Accessing the TCDR in 8-bit units is prohibited. Always access in 16-bit units.

### 9.3.25 Timer Cycle Buffer Register (TCBR)

TCBR is a 16-bit register used only in complementary PWM mode. It functions as a buffer register for the TCDR register. The TCB register values are transferred to the TCDR register with the transfer timing set in the TMDR register.

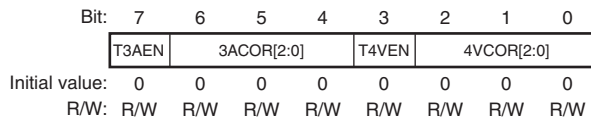
The initial value of TCB is H'FFFF.



Note: Accessing the TCB in 8-bit units is prohibited. Always access in 16-bit units.

### 9.3.26 Timer Interrupt Skipping Set Register (TITCR)

TITCR is an 8-bit readable/writable register that enables or disables interrupt skipping and specifies the interrupt skipping count. The MTU2 has one TITCR.



Bit	Bit Name	Initial value	R/W	Description
7	T3AEN	0	R/W	T3AEN Enables or disables TGIA_3 interrupt skipping. 0: TGIA_3 interrupt skipping disabled 1: TGIA_3 interrupt skipping enabled
6 to 4	3ACOR[2:0]	000	R/W	These bits specify the TGIA_3 interrupt skipping count within the range from 0 to 7.* For details, see table 9.40.
3	T4VEN	0	R/W	T4VEN Enables or disables TCIV_4 interrupt skipping. 0: TCIV_4 interrupt skipping disabled 1: TCIV_4 interrupt skipping enabled

Bit	Bit Name	Initial value	R/W	Description
2 to 0	4VCOR[2:0]	000	R/W	These bits specify the TCIV_4 interrupt skipping count within the range from 0 to 7.* For details, see table 9.41.

Note: \* When 0 is specified for the interrupt skipping count, no interrupt skipping will be performed. Before changing the interrupt skipping count, be sure to clear the T3AEN and T4VEN bits to 0 to clear the skipping counter (TITCNT).

**Table 9.40 Setting of Interrupt Skipping Count by Bits 3ACOR2 to 3ACOR0**

Bit 6	Bit 5	Bit 4	Description
3ACOR2	3ACOR1	3ACOR0	Description
0	0	0	Does not skip TGIA_3 interrupts.
0	0	1	Sets the TGIA_3 interrupt skipping count to 1.
0	1	0	Sets the TGIA_3 interrupt skipping count to 2.
0	1	1	Sets the TGIA_3 interrupt skipping count to 3.
1	0	0	Sets the TGIA_3 interrupt skipping count to 4.
1	0	1	Sets the TGIA_3 interrupt skipping count to 5.
1	1	0	Sets the TGIA_3 interrupt skipping count to 6.
1	1	1	Sets the TGIA_3 interrupt skipping count to 7.

**Table 9.41 Setting of Interrupt Skipping Count by Bits 4VCOR2 to 4VCOR0**

Bit 2	Bit 1	Bit 0	Description
4VCOR2	4VCOR1	4VCOR0	Description
0	0	0	Does not skip TCIV_4 interrupts.
0	0	1	Sets the TCIV_4 interrupt skipping count to 1.
0	1	0	Sets the TCIV_4 interrupt skipping count to 2.
0	1	1	Sets the TCIV_4 interrupt skipping count to 3.
1	0	0	Sets the TCIV_4 interrupt skipping count to 4.
1	0	1	Sets the TCIV_4 interrupt skipping count to 5.
1	1	0	Sets the TCIV_4 interrupt skipping count to 6.
1	1	1	Sets the TCIV_4 interrupt skipping count to 7.



### 9.3.27 Timer Interrupt Skipping Counter (TITCNT)

TITCNT is an 8-bit readable/writable counter. The MTU2 has one TITCNT.

Bit:	7	6	5	4	3	2	1	0
	-	3ACNT[2:0]			-	4VCNT[2:0]		
Initial value:	0	0	0	0	0	0	0	0
R/W:	R	R	R	R	R	R	R	R

Bit	Bit Name	Initial Value	R/W	Description
7	—	0	R	Reserved This bit is always read as 0.
6 to 4	3ACNT[2:0]	000	R	TGIA_3 Interrupt Counter While the T3AEN bit in TITCR is set to 1, the count in these bits is incremented every time a TGIA_3 interrupt occurs. [Clearing conditions] <ul style="list-style-type: none"> <li>• When the 3ACNT2 to 3ACNT0 value in TITCNT matches the 3ACOR2 to 3ACOR0 value in TITCR</li> <li>• When the T3AEN bit in TITCR is cleared to 0</li> <li>• When the 3ACOR2 to 3ACOR0 bits in TITCR are cleared to 0</li> </ul>
3	—	0	R	Reserved This bit is always read as 0.
2 to 0	4VCNT[2:0]	000	R	TCIV_4 Interrupt Counter While the T4VEN bit in TITCR is set to 1, the count in these bits is incremented every time a TCIV_4 interrupt occurs. [Clearing conditions] <ul style="list-style-type: none"> <li>• When the 4VCNT2 to 4VCNT0 value in TITCNT matches the 4VCOR2 to 4VCOR2 value in TITCR</li> <li>• When the T4VEN bit in TITCR is cleared to 0</li> <li>• When the 4VCOR2 to 4VCOR2 bits in TITCR are cleared to 0</li> </ul>

### 9.3.28 Timer Buffer Transfer Set Register (TBTER)

TBTER is an 8-bit readable/writable register that enables or disables transfer from the buffer registers\* used in complementary PWM mode to the temporary registers and specifies whether to link the transfer with interrupt skipping operation. The MTU2 has one TBTER.

Bit:	7	6	5	4	3	2	1	0
	-	-	-	-	-	-	BTE[1:0]	
Initial value:	0	0	0	0	0	0	0	0
R/W:	R	R	R	R	R	R	R/W	R/W

Bit	Bit Name	Initial Value	R/W	Description
7 to 2	—	All 0	R	Reserved  These bits are always read as 0. The write value should always be 0.
1, 0	BTE[1:0]	00	R/W	These bits enable or disable transfer from the buffer registers* used in complementary PWM mode to the temporary registers and specify whether to link the transfer with interrupt skipping operation.  For details, see table 9.42.

Note: \* Applicable buffer registers:  
TGRC\_3, TGRD\_3, TGRC\_4, TGRD\_4, and TCBR

**Table 9.42 Setting of Bits BTE1 and BTE0**

Bit 1	Bit 0	
BTE1	BTE0	Description
0	0	Enables transfer from the buffer registers to the temporary registers* <sup>1</sup> and does not link the transfer with interrupt skipping operation.
0	1	Disables transfer from the buffer registers to the temporary registers.
1	0	Links transfer from the buffer registers to the temporary registers with interrupt skipping operation.* <sup>2</sup>
1	1	Setting prohibited

- Notes:
1. Data is transferred according to the MD3 to MD0 bit setting in TMDR. For details, refer to section 9.4.8, Complementary PWM Mode.
  2. When interrupt skipping is disabled (the T3AEN and T4VEN bits are cleared to 0 in the timer interrupt skipping set register (TITCR) or the skipping count set bits (3ACOR and 4VCOR) in TITCR are cleared to 0)), be sure to disable link of buffer transfer with interrupt skipping (clear the BTE1 bit in the timer buffer transfer set register (TBTER) to 0). If link with interrupt skipping is enabled while interrupt skipping is disabled, buffer transfer will not be performed.

### 9.3.29 Timer Dead Time Enable Register (TDER)

TDER is an 8-bit readable/writable register that controls dead time generation in complementary PWM mode. The MTU2 has one TDER in channel 3. TDER must be modified only while TCNT stops.

Bit:	7	6	5	4	3	2	1	0
	-	-	-	-	-	-	-	TDER
Initial value:	0	0	0	0	0	0	0	1
R/W:	R	R	R	R	R	R	R	R/(W)

Bit	Bit Name	Initial Value	R/W	Description
7 to 1	—	All 0	R	Reserved  These bits are always read as 0. The write value should always be 0.
0	TDER	1	R/(W)	Dead Time Enable  Specifies whether to generate dead time. 0: Does not generate dead time 1: Generates dead time*  [Clearing condition]  • When 0 is written to TDER after reading TDER = 1

Note: \* TDDR must be set to 1 or a larger value.

### 9.3.30 Timer Waveform Control Register (TWCR)

TWCR is an 8-bit readable/writable register that controls the waveform when synchronous counter clearing occurs in TCNT\_3 and TCNT\_4 in complementary PWM mode and specifies whether to clear the counters at TGRA\_3 compare match. The CCE bit and WRE bit in TWCR must be modified only while TCNT stops.

Bit:	7	6	5	4	3	2	1	0
	CCE	-	-	-	-	-	-	WRE
Initial value:	0*	0	0	0	0	0	0	0
R/W:	R/(W)	R	R	R	R	R	R	R/(W)

Note: \* Do not set to 1 when complementary PWM mode is not selected.

Bit	Bit Name	Initial Value	R/W	Description
7	CCE	0*	R/(W)	Compare Match Clear Enable Specifies whether to clear counters at TGRA_3 compare match in complementary PWM mode. 0: Does not clear counters at TGRA_3 compare match 1: Clears counters at TGRA_3 compare match [Setting condition] <ul style="list-style-type: none"> <li>• When 1 is written to CCE after reading CCE = 0</li> </ul>
6 to 1	—	All 0	R	Reserved These bits are always read as 0. The write value should always be 0.

Bit	Bit Name	Initial Value	R/W	Description
0	WRE	0	R/(W)	<p>Waveform Retain Enable</p> <p>Selects the waveform output when synchronous counter clearing occurs in complementary PWM mode. The output waveform is retained only when synchronous clearing occurs within the Tb interval at the trough in complementary PWM mode. When synchronous clearing occurs outside this interval, the initial value specified in TOCR is output regardless of the WRE bit setting. The initial value is also output when synchronous clearing occurs in the Tb interval at the trough immediately after TCNT_3 and TCNT_4 start operation.</p> <p>For the Tb interval at the trough in complementary PWM mode, see figure 9.40.</p> <p>0: Outputs the initial value specified in TOCR 1: Retains the waveform output immediately before synchronous clearing</p> <p>[Setting condition]</p> <ul style="list-style-type: none"> <li>When 1 is written to WRE after reading WRE = 0</li> </ul>

Note: \* Do not set to 1 when complementary PWM mode is not selected.

### 9.3.31 Bus Master Interface

The timer counters (TCNT), general registers (TGR), timer subcounter (TCNTS), timer cycle buffer register (TCBR), timer dead time data register (TDDR), timer cycle data register (TCDR), timer A/D converter start request control register (TADCR), timer A/D converter start request cycle set registers (TADCOR), and timer A/D converter start request cycle set buffer registers (TADCOBR) are 16-bit registers. A 16-bit data bus to the bus master enables 16-bit read/writes. 8-bit read/write is not possible. Always access in 16-bit units.

All registers other than the above registers are 8-bit registers. These are connected to the CPU by a 16-bit data bus, so 16-bit read/writes and 8-bit read/writes are both possible.

## 9.4 Operation

### 9.4.1 Basic Functions

Each channel has a TCNT and TGR register. TCNT performs up-counting, and is also capable of free-running operation, cycle counting, and external event counting.

Each TGR can be used as an input capture register or output compare register.

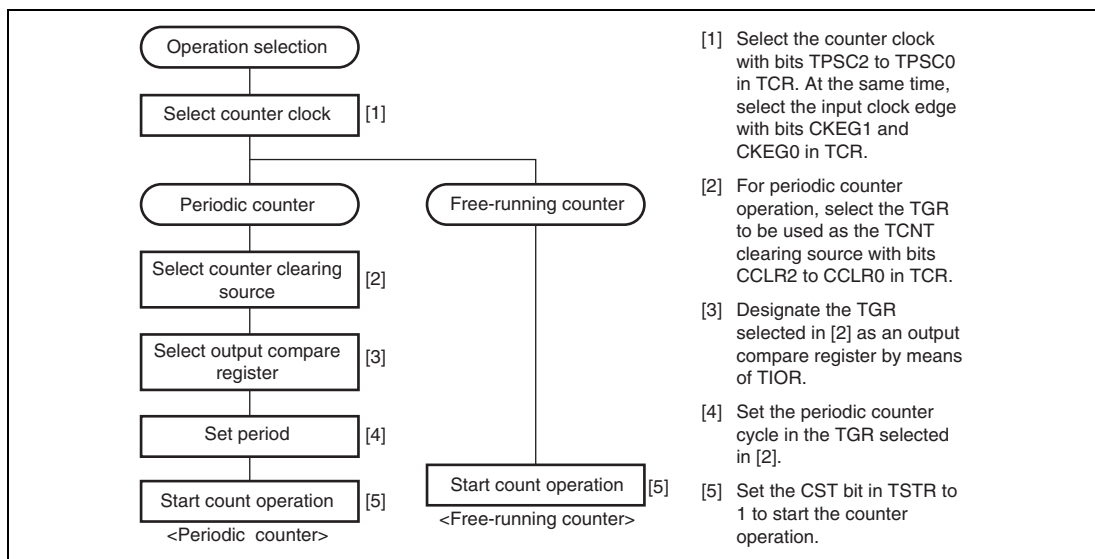
Always select MTU2 external pins set function using the pin function controller (PFC).

#### Counter Operation:

When one of bits CST0 to CST4 in TSTR or bits CSTU5, CSTV5, and CSTW5 in TSTR\_5 is set to 1, the TCNT counter for the corresponding channel begins counting. TCNT can operate as a free-running counter, periodic counter, for example.

#### 1. Example of Count Operation Setting Procedure

Figure 9.4 shows an example of the count operation setting procedure.

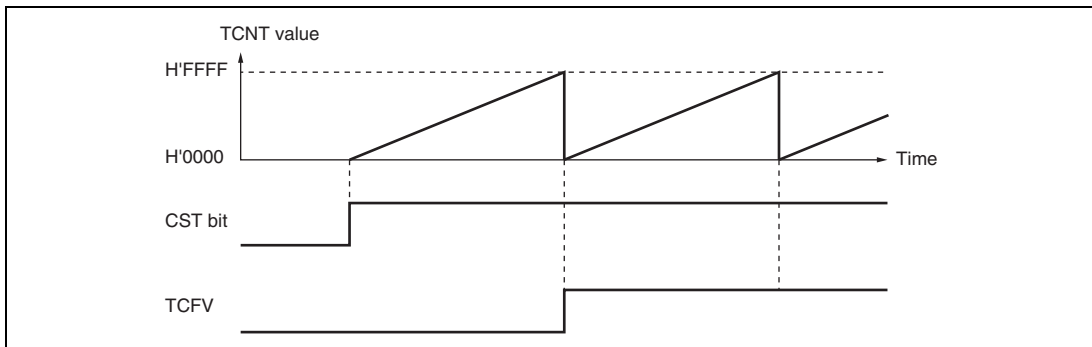


**Figure 9.4 Example of Counter Operation Setting Procedure**

## 2. Free-Running Count Operation and Periodic Count Operation:

Immediately after a reset, the MTU2's TCNT counters are all designated as free-running counters. When the relevant bit in TSTR is set to 1 the corresponding TCNT counter starts up-count operation as a free-running counter. When TCNT overflows (from H'FFFF to H'0000), the TCFV bit in TSR is set to 1. If the value of the corresponding TCIEV bit in TIER is 1 at this point, the MTU2 requests an interrupt. After overflow, TCNT starts counting up again from H'0000.

Figure 9.5 illustrates free-running counter operation.



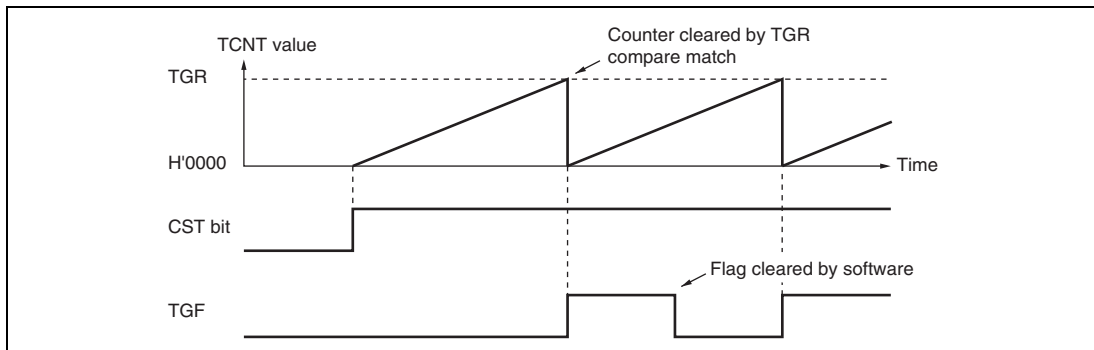
**Figure 9.5 Free-Running Counter Operation**

When compare match is selected as the TCNT clearing source, the TCNT counter for the relevant channel performs periodic count operation. The TGR register for setting the period is designated as an output compare register, and counter clearing by compare match is selected by means of bits CCLR0 to CCLR2 in TCR. After the settings have been made, TCNT starts up-count operation as a periodic counter when the corresponding bit in TSTR is set to 1. When the count value matches the value in TGR, the TGF bit in TSR is set to 1 and TCNT is cleared to H'0000.

If the value of the corresponding TGIE bit in TIER is 1 at this point, the MTU2 requests an interrupt. After a compare match, TCNT starts counting up again from H'0000.



Figure 9.6 illustrates periodic counter operation.



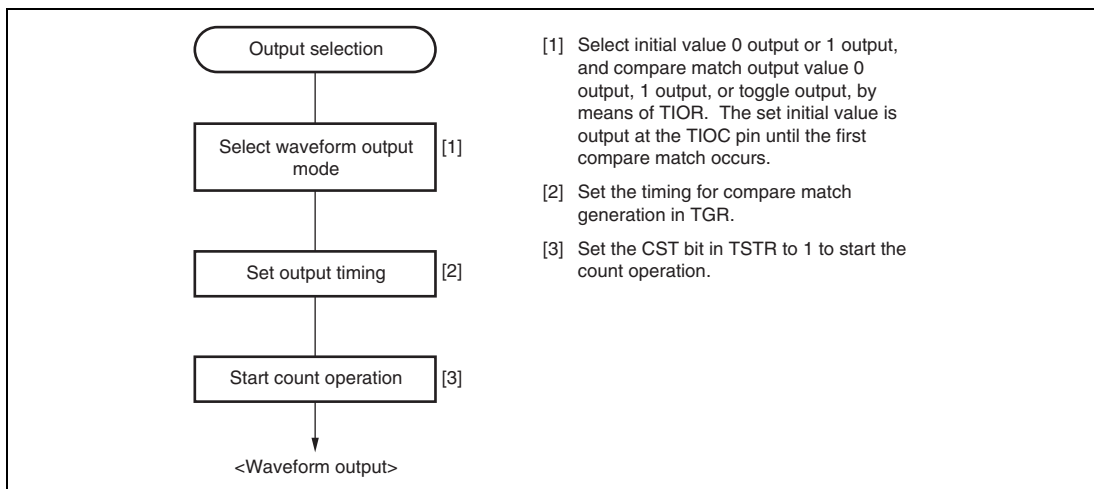
**Figure 9.6 Periodic Counter Operation**

### Waveform Output by Compare Match:

The MTU2 can perform 0, 1, or toggle output from the corresponding output pin using compare match.

#### 1. Example of Setting Procedure for Waveform Output by Compare Match

Figure 9.7 shows an example of the setting procedure for waveform output by compare match

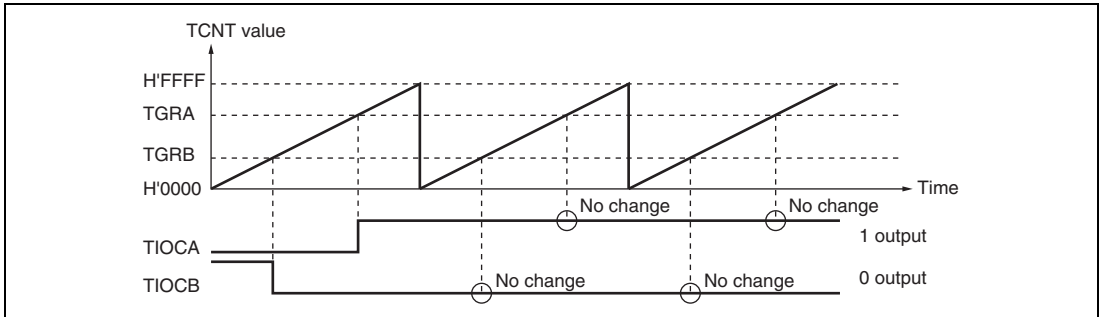


**Figure 9.7 Example of Setting Procedure for Waveform Output by Compare Match**

## 2. Examples of Waveform Output Operation:

Figure 9.8 shows an example of 0 output/1 output.

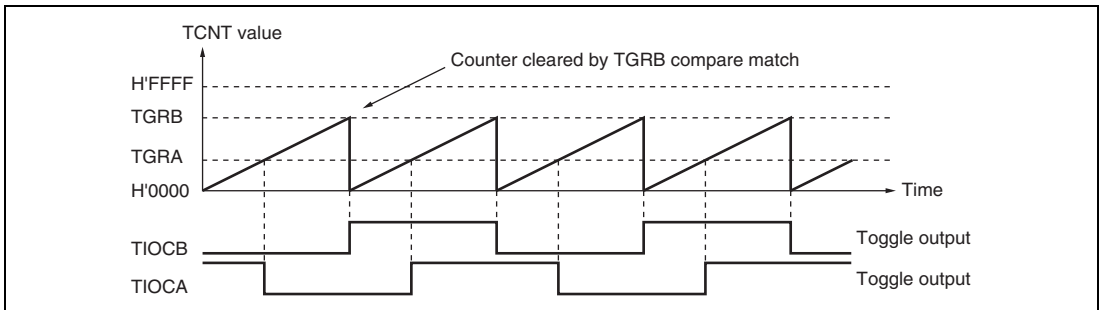
In this example, TCNT has been designated as a free-running counter, and settings have been made such that 1 is output by compare match A, and 0 is output by compare match B. When the set level and the pin level coincide, the pin level does not change.



**Figure 9.8 Example of 0 Output/1 Output Operation**

Figure 9.9 shows an example of toggle output.

In this example, TCNT has been designated as a periodic counter (with counter clearing on compare match B), and settings have been made such that the output is toggled by both compare match A and compare match B.



**Figure 9.9 Example of Toggle Output Operation**

## Input Capture Function:

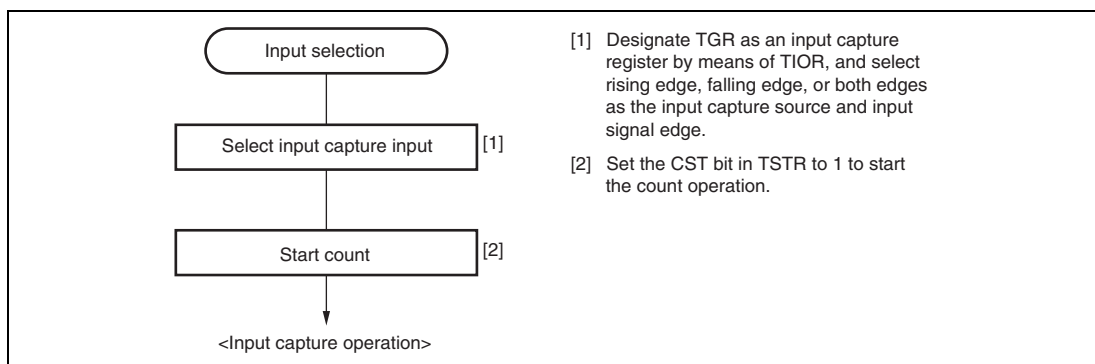
The TCNT value can be transferred to TGR on detection of the TIOC pin input edge.

Rising edge, falling edge, or both edges can be selected as the detected edge. For channels 0 and 1, it is also possible to specify another channel's counter input clock or compare match signal as the input capture source.

Note: When another channel's counter input clock is used as the input capture input for channels 0 and 1,  $MP\phi/1$  should not be selected as the counter input clock used for input capture input. Input capture will not be generated if  $MP\phi/1$  is selected.

### 1. Example of Input Capture Operation Setting Procedure

Figure 9.10 shows an example of the input capture operation setting procedure.

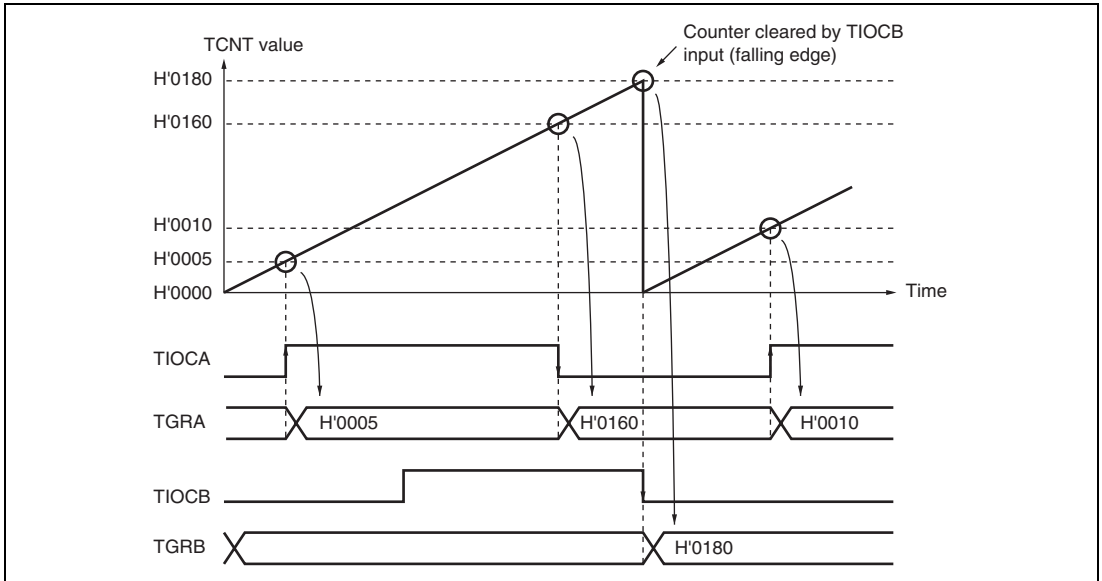


**Figure 9.10 Example of Input Capture Operation Setting Procedure**

## 2. Example of Input Capture Operation:

Figure 9.11 shows an example of input capture operation.

In this example both rising and falling edges have been selected as the TIOCA pin input capture input edge, the falling edge has been selected as the TIOCB pin input capture input edge, and counter clearing by TGRB input capture has been designated for TCNT.



**Figure 9.11 Example of Input Capture Operation**

## 9.4.2 Synchronous Operation

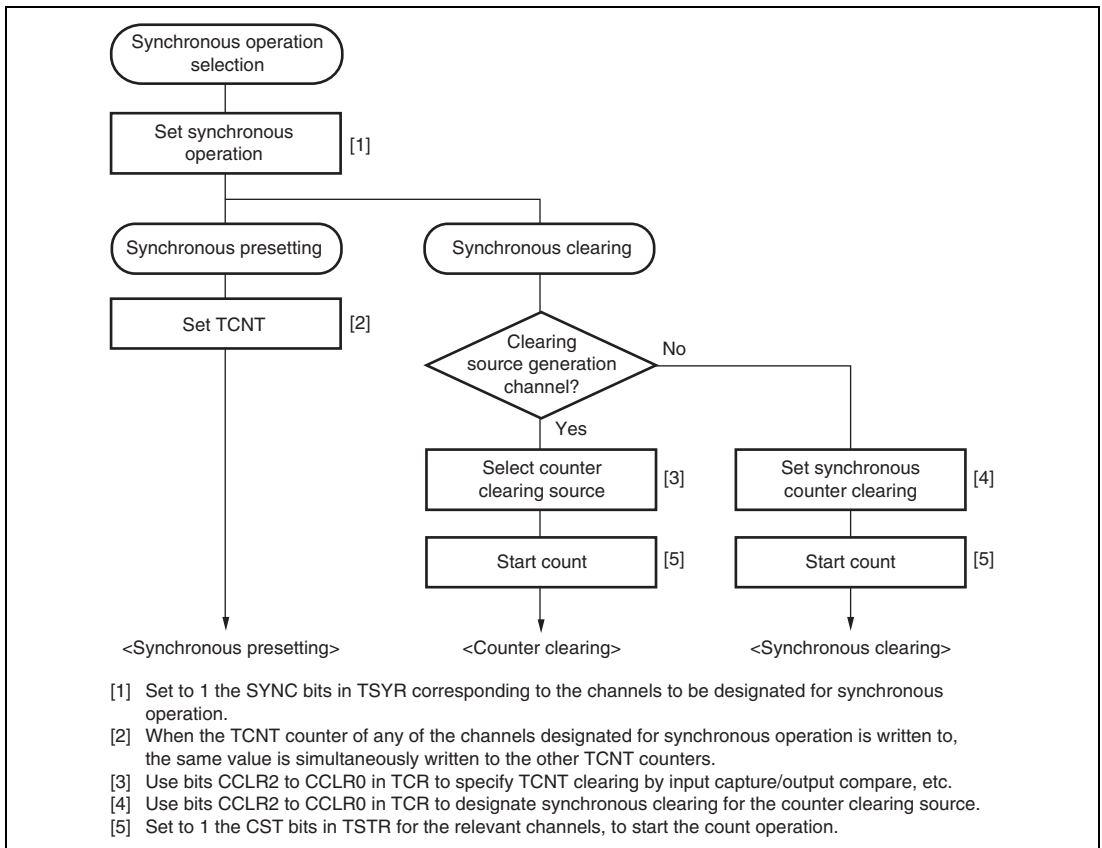
In synchronous operation, the values in a number of TCNT counters can be rewritten simultaneously (synchronous presetting). Also, a number of TCNT counters can be cleared simultaneously by making the appropriate setting in TCR (synchronous clearing).

Synchronous operation enables TGR to be incremented with respect to a single time base.

Channels 0 to 4 can all be designated for synchronous operation. Channel 5 cannot be used for synchronous operation.

### Example of Synchronous Operation Setting Procedure:

Figure 9.12 shows an example of the synchronous operation setting procedure.



**Figure 9.12 Example of Synchronous Operation Setting Procedure**

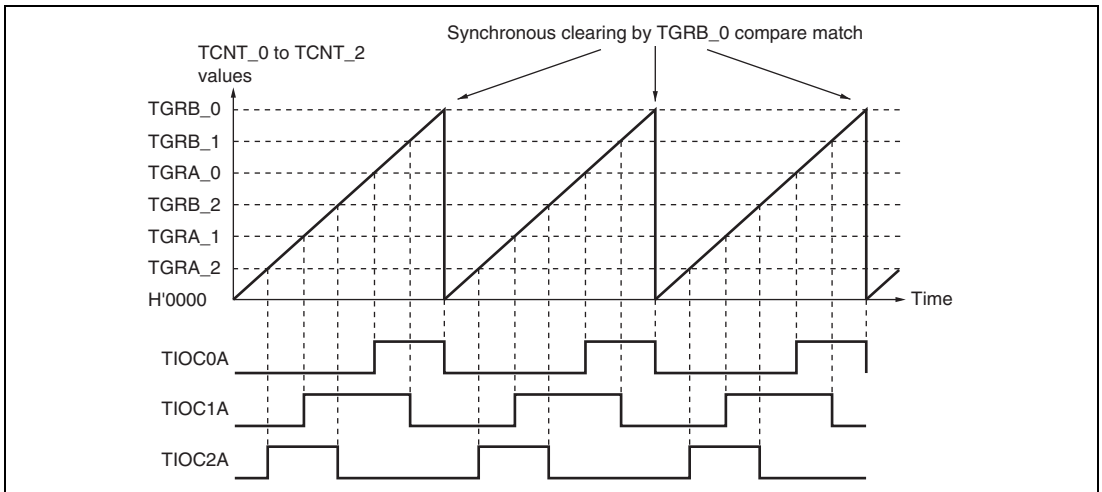
### Example of Synchronous Operation in SH7125:

Figure 9.13 shows an example of synchronous operation.

In this example, synchronous operation and PWM mode 1 have been designated for channels 0 to 2, TGRB\_0 compare match has been set as the channel 0 counter clearing source, and synchronous clearing has been set for the channel 1 and 2 counter clearing source.

Three-phase PWM waveforms are output from pins TIOC0A, TIOC1A, and TIOC2A. At this time, synchronous presetting, and synchronous clearing by TGRB\_0 compare match, are performed for channel 0 to 2 TCNT counters, and the data set in TGRB\_0 is used as the PWM cycle.

For details of PWM modes, see section 9.4.5, PWM Modes.



**Figure 9.13 Example of Synchronous Operation**

### 9.4.3 Buffer Operation

Buffer operation, provided for channels 0, 3, and 4, enables TGRC and TGRD to be used as buffer registers. In channel 0, TGRF can also be used as a buffer register.

Buffer operation differs depending on whether TGR has been designated as an input capture register or as a compare match register.

Note: TGRE\_0 cannot be designated as an input capture register and can only operate as a compare match register.

Table 9.43 shows the register combinations used in buffer operation.

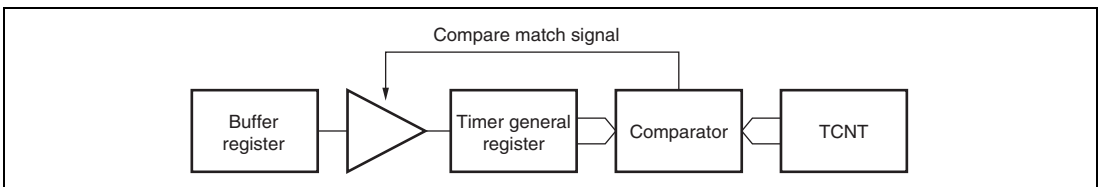
**Table 9.43 Register Combinations in Buffer Operation**

Channel	Timer General Register	Buffer Register
0	TGRA_0	TGRC_0
	TGRB_0	TGRD_0
	TGRE_0	TGRF_0
3	TGRA_3	TGRC_3
	TGRB_3	TGRD_3
4	TGRA_4	TGRC_4
	TGRB_4	TGRD_4

- When TGR is an output compare register

When a compare match occurs, the value in the buffer register for the corresponding channel is transferred to the timer general register.

This operation is illustrated in figure 9.14.

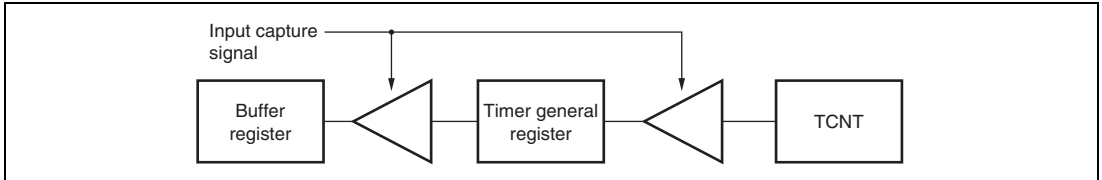


**Figure 9.14 Compare Match Buffer Operation**

- When TGR is an input capture register

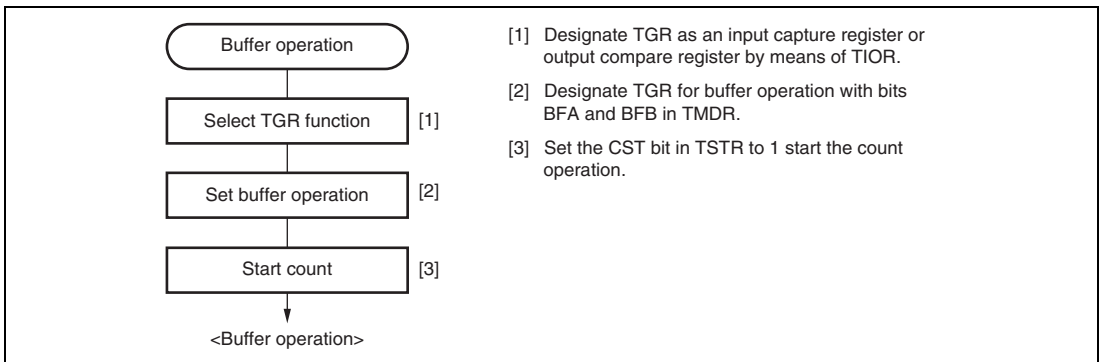
When input capture occurs, the value in TCNT is transferred to TGR and the value previously held in the timer general register is transferred to the buffer register.

This operation is illustrated in figure 9.15.



**Figure 9.15 Input Capture Buffer Operation**

**Example of Buffer Operation Setting Procedure:** Figure 9.16 shows an example of the buffer operation setting procedure.



**Figure 9.16 Example of Buffer Operation Setting Procedure**



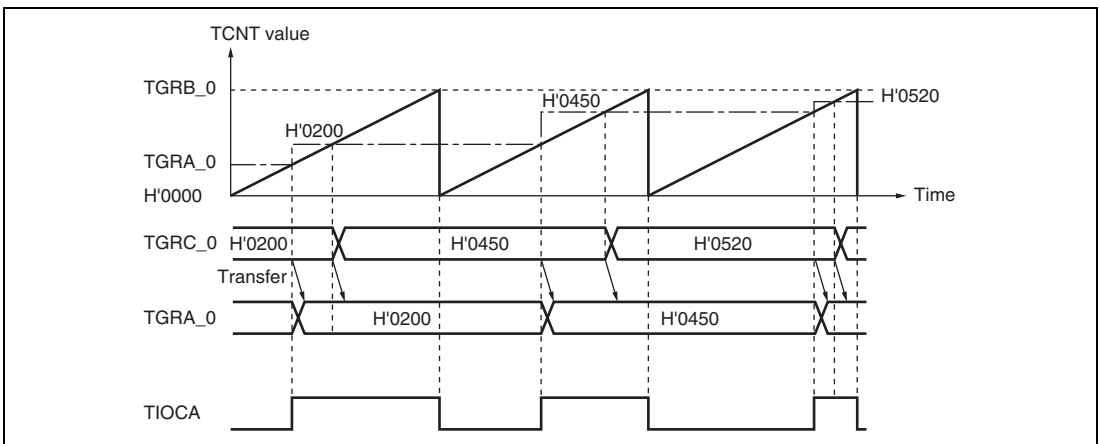
## Examples of Buffer Operation:

### 1. When TGR is an output compare register

Figure 9.17 shows an operation example in which PWM mode 1 has been designated for channel 0, and buffer operation has been designated for TGRA and TGRC. The settings used in this example are TCNT clearing by compare match B, 1 output at compare match A, and 0 output at compare match B. In this example, the TTSA bit in TBTM is cleared to 0.

As buffer operation has been set, when compare match A occurs the output changes and the value in buffer register TGRC is simultaneously transferred to timer general register TGRA. This operation is repeated each time that compare match A occurs.

For details of PWM modes, see section 9.4.5, PWM Modes.



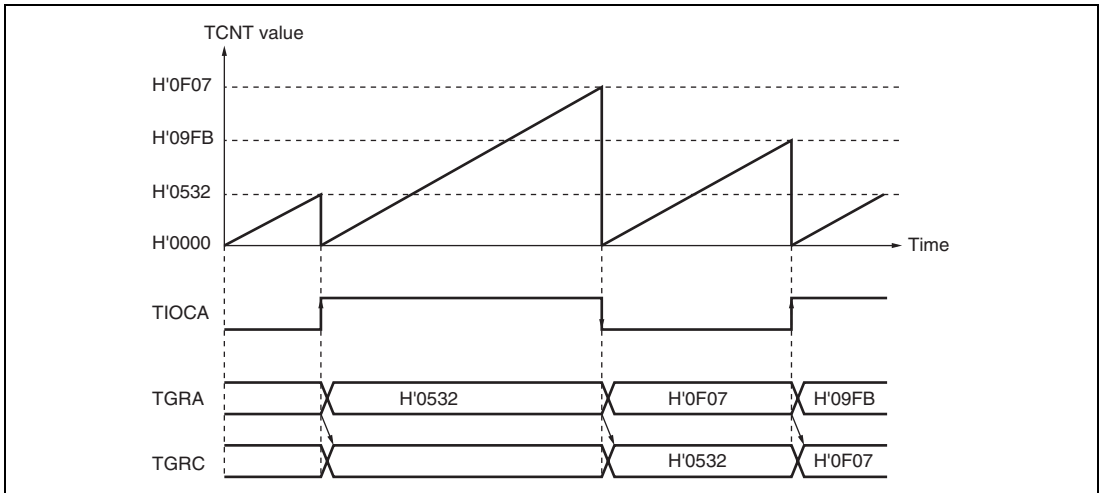
**Figure 9.17 Example of Buffer Operation (1)**

### 2. When TGR is an input capture register

Figure 9.18 shows an operation example in which TGRA has been designated as an input capture register, and buffer operation has been designated for TGRA and TGRC.

Counter clearing by TGRA input capture has been set for TCNT, and both rising and falling edges have been selected as the TIOCA pin input capture input edge.

As buffer operation has been set, when the TCNT value is stored in TGRA upon the occurrence of input capture A, the value previously stored in TGRA is simultaneously transferred to TGRC.



**Figure 9.18 Example of Buffer Operation (2)**

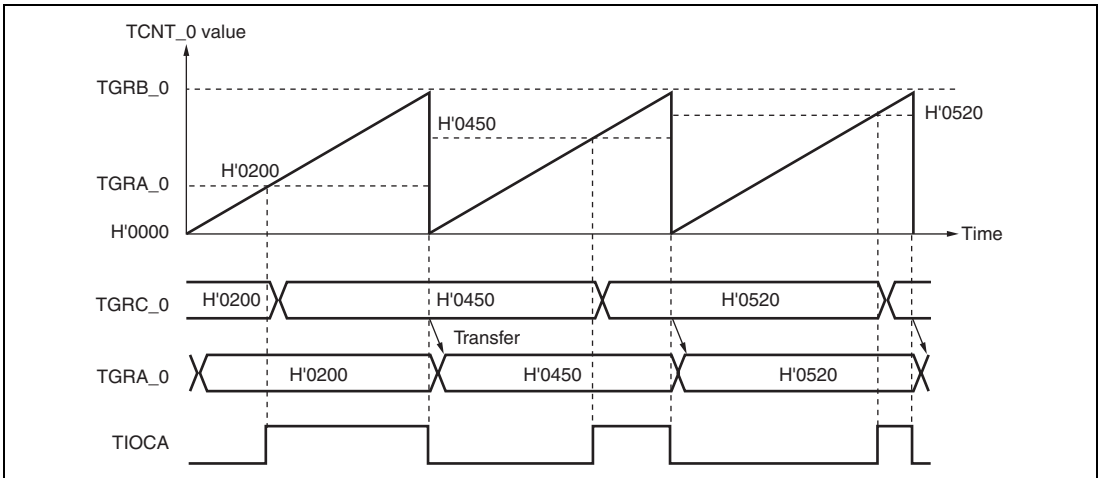
#### Selecting Timing for Transfer from Buffer Registers to Timer General Registers in Buffer

**Operation:** The timing for transfer from buffer registers to timer general registers can be selected in PWM mode 1 or 2 for channel 0 or in PWM mode 1 for channels 3 and 4 by setting the buffer operation transfer mode registers (TBTM\_0, TBTM\_3, and TBTM\_4). Either compare match (initial setting) or TCNT clearing can be selected for the transfer timing. TCNT clearing as transfer timing is one of the following cases.

- When TCNT overflows (H'FFFF to H'0000)
- When H'0000 is written to TCNT during counting
- When TCNT is cleared to H'0000 under the condition specified in the CCLR2 to CCLR0 bits in TCR

Note: TBTM must be modified only while TCNT stops.

Figure 9.19 shows an operation example in which PWM mode 1 is designated for channel 0 and buffer operation is designated for TGRA\_0 and TGRC\_0. The settings used in this example are TCNT\_0 clearing by compare match B, 1 output at compare match A, and 0 output at compare match B. The TTSA bit in TBTM\_0 is set to 1.



**Figure 9.19 Example of Buffer Operation When TCNT\_0 Clearing is Selected for TGRC\_0 to TGRA\_0 Transfer Timing**

#### 9.4.4 Cascaded Operation

In cascaded operation, two 16-bit counters for different channels are used together as a 32-bit counter.

This function works by counting the channel 1 counter clock upon overflow/underflow of TCNT\_2 as set in bits TPSC0 to TPSC2 in TCR.

Underflow occurs only when the lower 16-bit TCNT is in phase-counting mode.

Table 9.44 shows the register combinations used in cascaded operation.

Note: When phase counting mode is set for channel 1, the counter clock setting is invalid and the counters operates independently in phase counting mode.

**Table 9.44 Cascaded Combinations**

Combination	Upper 16 Bits	Lower 16 Bits
Channels 1 and 2	TCNT_1	TCNT_2

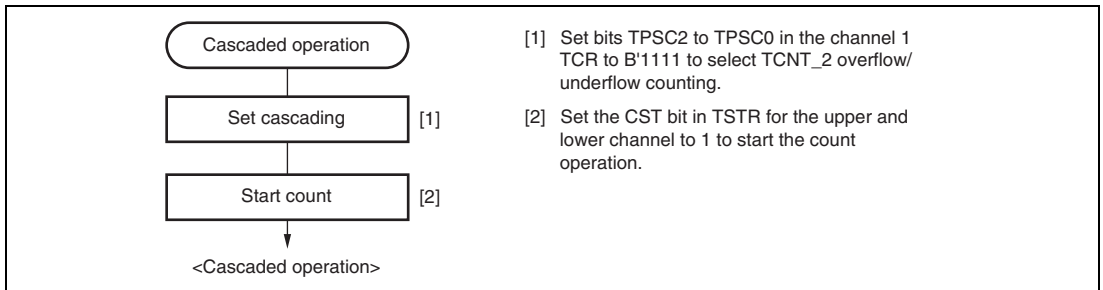
For simultaneous input capture of TCNT\_1 and TCNT\_2 during cascaded operation, additional input capture input pins can be specified by the input capture control register (TICCR). For input capture in cascade connection, refer to section 9.7.22, Simultaneous Capture of TCNT\_1 and TCNT\_2 in Cascade Connection.

Table 9.45 shows the TICCRR setting and input capture input pins.

**Table 9.45 TICCRR Setting and Input Capture Input Pins**

Target Input Capture	TICCRR Setting	Input Capture Input Pins
Input capture from TCNT_1 to TGRA_1	I2AE bit = 0 (initial value)	TIOC1A
	I2AE bit = 1	TIOC1A, TIOC2A
Input capture from TCNT_1 to TGRB_1	I2BE bit = 0 (initial value)	TIOC1B
	I2BE bit = 1	TIOC1B, TIOC2B
Input capture from TCNT_2 to TGRA_2	I1AE bit = 0 (initial value)	TIOC2A
	I1AE bit = 1	TIOC2A, TIOC1A
Input capture from TCNT_2 to TGRB_2	I1BE bit = 0 (initial value)	TIOC2B
	I1BE bit = 1	TIOC2B, TIOC1B

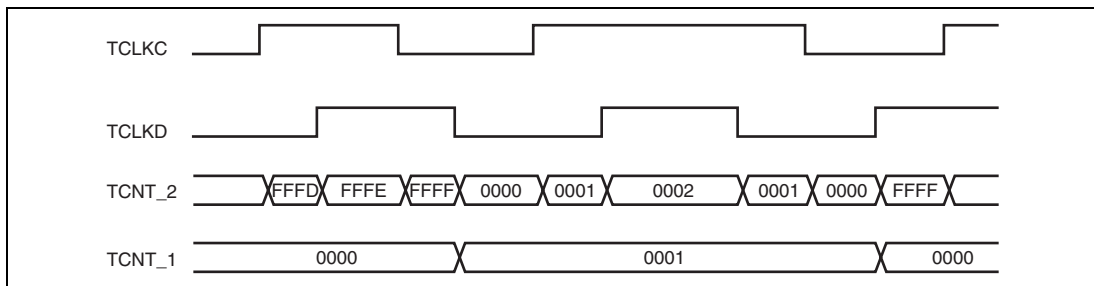
**Example of Cascaded Operation Setting Procedure:** Figure 9.20 shows an example of the setting procedure for cascaded operation.



**Figure 9.20 Cascaded Operation Setting Procedure**

**Cascaded Operation Example (a):** Figure 9.21 illustrates the operation when TCNT\_2 overflow/underflow counting has been set for TCNT\_1 and phase counting mode has been designated for channel 2.

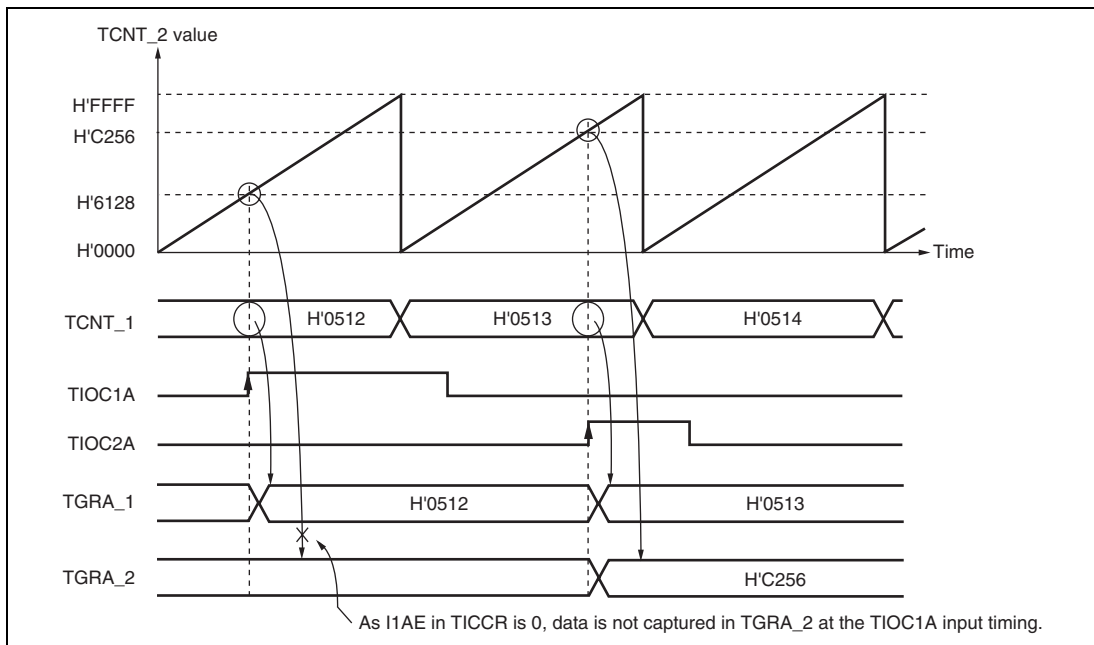
TCNT\_1 is incremented by TCNT\_2 overflow and decremented by TCNT\_2 underflow.



**Figure 9.21 Cascaded Operation Example (a)**

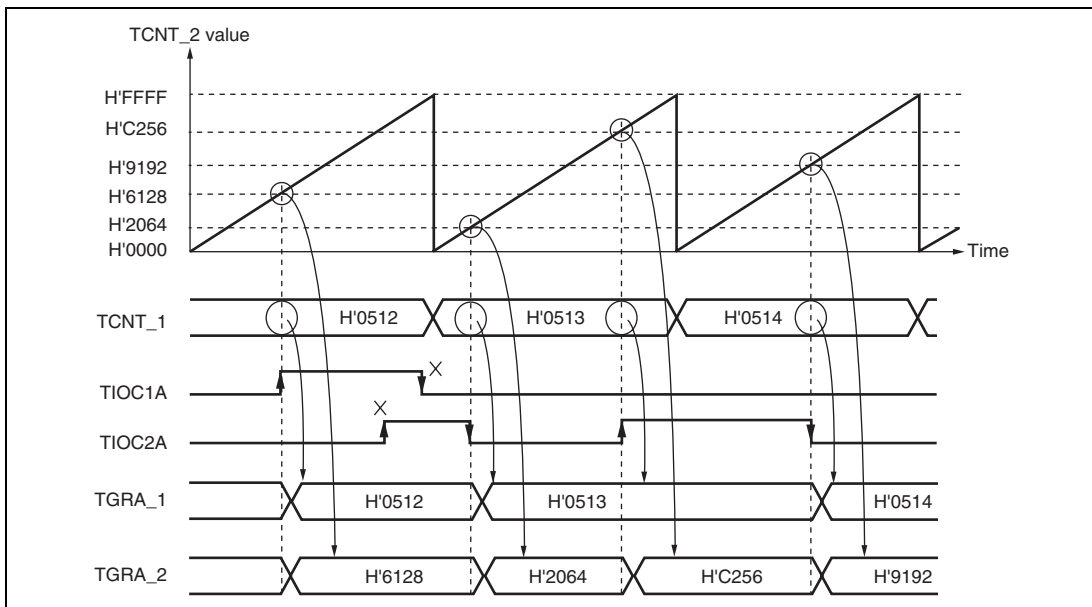
**Cascaded Operation Example (b) in SH7125:** Figure 9.22 illustrates the operation when TCNT\_1 and TCNT\_2 have been cascaded and the I2AE bit in TICCR has been set to 1 to include the TIOC2A pin in the TGRA\_1 input capture conditions. In this example, the IOA0 to IOA3 bits in TIOR\_1 have selected the TIOC1A rising edge for the input capture timing while the IOA0 to IOA3 bits in TIOR\_2 have selected the TIOC2A rising edge for the input capture timing.

Under these conditions, the rising edge of both TIOC1A and TIOC2A is used for the TGRA\_1 input capture condition. For the TGRA\_2 input capture condition, the TIOC2A rising edge is used.



**Figure 9.22 Cascaded Operation Example (b)**

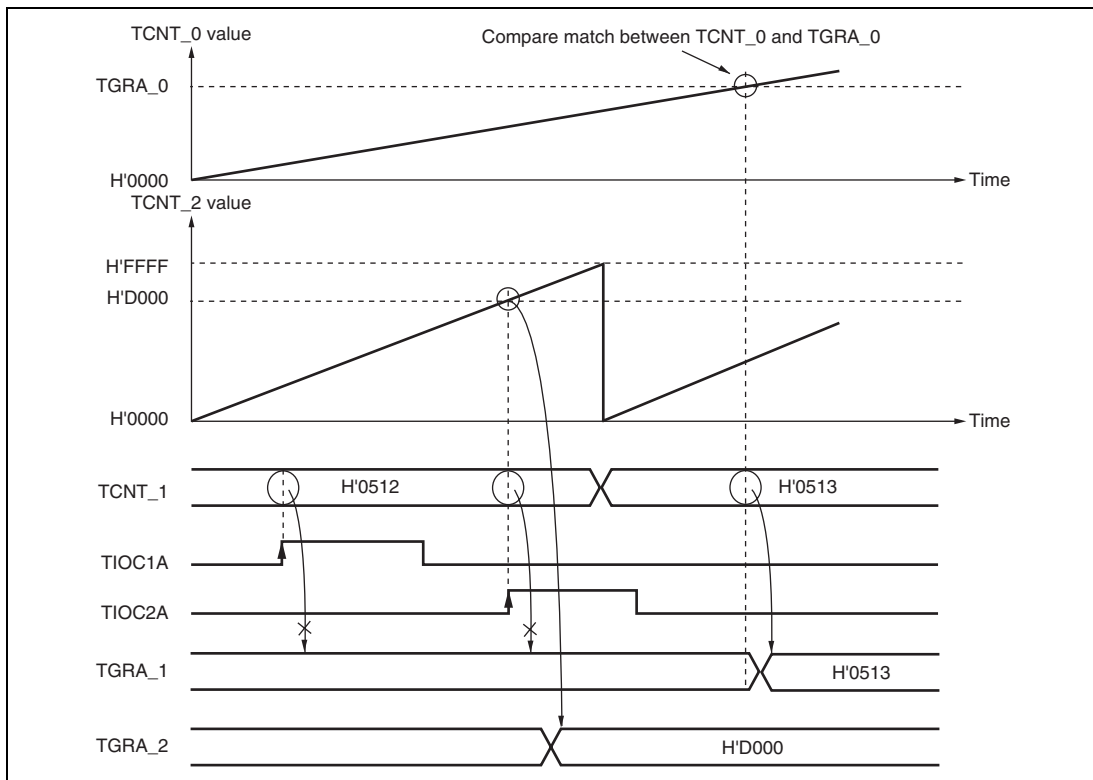
**Cascaded Operation Example (c) in SH7125:** Figure 9.23 illustrates the operation when TCNT\_1 and TCNT\_2 have been cascaded and the I2AE and I1AE bits in TICCRR have been set to 1 to include the TIOC2A and TIOC1A pins in the TGRA\_1 and TGRA\_2 input capture conditions, respectively. In this example, the IOA0 to IOA3 bits in both TIOR\_1 and TIOR\_2 have selected both the rising and falling edges for the input capture timing. Under these conditions, the ORed result of TIOC1A and TIOC2A input is used for the TGRA\_1 and TGRA\_2 input capture conditions.



**Figure 9.23 Cascaded Operation Example (c)**

**Cascaded Operation Example (d) in SH7125:** Figure 9.24 illustrates the operation when TCNT\_1 and TCNT\_2 have been cascaded and the I2AE bit in TICCRR has been set to 1 to include the TIOC2A pin in the TGRA\_1 input capture conditions. In this example, the IOA0 to IOA3 bits in TIOR\_1 have selected TGRA\_0 compare match or input capture occurrence for the input capture timing while the IOA0 to IOA3 bits in TIOR\_2 have selected the TIOC2A rising edge for the input capture timing.

Under these conditions, as TIOR\_1 has selected TGRA\_0 compare match or input capture occurrence for the input capture timing, the TIOC2A edge is not used for TGRA\_1 input capture condition although the I2AE bit in TICCRR has been set to 1.



**Figure 9.24 Cascaded Operation Example (d)**

### 9.4.5 PWM Modes

In PWM mode, PWM waveforms are output from the output pins. The output level can be selected as 0, 1, or toggle output in response to a compare match of each TGR.

TGR registers settings can be used to output a PWM waveform in the range of 0% to 100% duty.

Designating TGR compare match as the counter clearing source enables the period to be set in that register. All channels can be designated for PWM mode independently. Synchronous operation is also possible.

There are two PWM modes, as described below.

#### 1. PWM mode 1

PWM output is generated from the TIOCA and TIOCC pins by pairing TGRA with TGRB and TGRC with TGRD. The output specified by bits IOA0 to IOA3 and IOC0 to IOC3 in TIOR is output from the TIOCA and TIOCC pins at compare matches A and C, and the output specified by bits IOB0 to IOB3 and IOD0 to IOD3 in TIOR is output at compare matches B and D. The initial output value is the value set in TGRA or TGRC. If the set values of paired TGRs are identical, the output value does not change when a compare match occurs.

In PWM mode 1, a maximum 8-phase PWM output is possible.

#### 2. PWM mode 2

PWM output is generated using one TGR as the cycle register and the others as duty registers. The output specified in TIOR is performed by means of compare matches. Upon counter clearing by a synchronization register compare match, the output value of each pin is the initial value set in TIOR. If the set values of the cycle and duty registers are identical, the output value does not change when a compare match occurs.

In PWM mode 2, a maximum 8-phase PWM output is possible in combination use with synchronous operation.

The correspondence between PWM output pins and registers is shown in table 9.46.



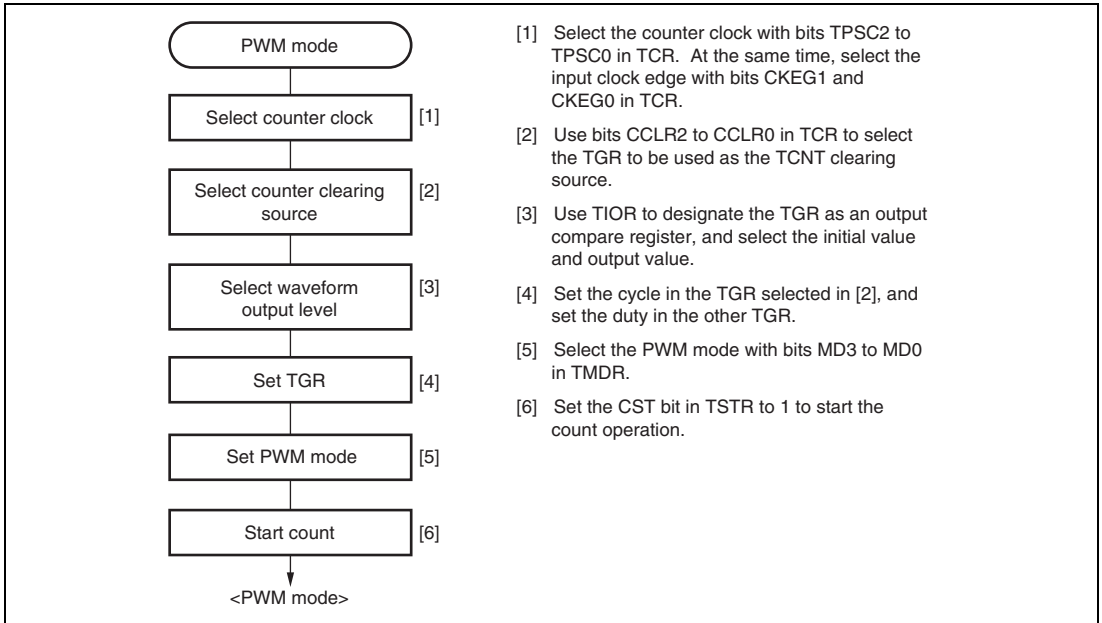
**Table 9.46 PWM Output Registers and Output Pins**

Channel	Registers	Output Pins	
		PWM Mode 1	PWM Mode 2
0	TGRA_0	TIOC0A	TIOC0A
	TGRB_0		TIOC0B
	TGRC_0	TIOC0C	TIOC0C
	TGRD_0		TIOC0D
1	TGRA_1	TIOC1A*	TIOC1A*
	TGRB_1		TIOC1B*
2	TGRA_2	TIOC2A*	TIOC2A*
	TGRB_2		TIOC2B*
3	TGRA_3	TIOC3A	Cannot be set
	TGRB_3		Cannot be set
	TGRC_3	TIOC3C	Cannot be set
	TGRD_3		Cannot be set
4	TGRA_4	TIOC4A	Cannot be set
	TGRB_4		Cannot be set
	TGRC_4	TIOC4C	Cannot be set
	TGRD_4		Cannot be set

Notes: In PWM mode 2, PWM output is not possible for the TGR register in which the period is set.

\* Supported only by the SH7125.

**Example of PWM Mode Setting Procedure:** Figure 9.25 shows an example of the PWM mode setting procedure.

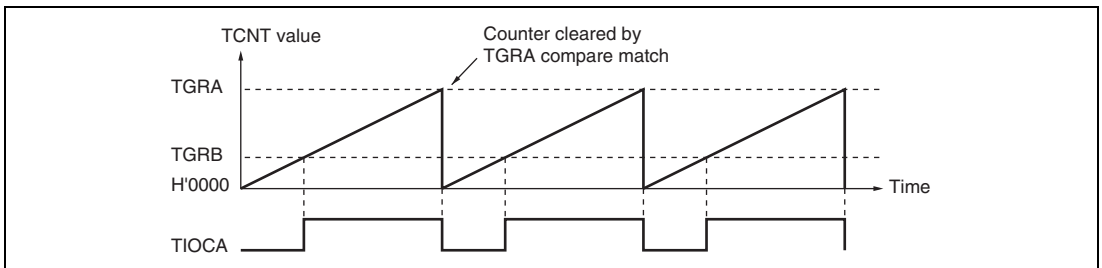


**Figure 9.25 Example of PWM Mode Setting Procedure**

**Examples of PWM Mode Operation:** Figure 9.26 shows an example of PWM mode 1 operation.

In this example, TGRA compare match is set as the TCNT clearing source, 0 is set for the TGRA initial output value and output value, and 1 is set as the TGRB output value.

In this case, the value set in TGRA is used as the period, and the values set in the TGRB registers are used as the duty levels.

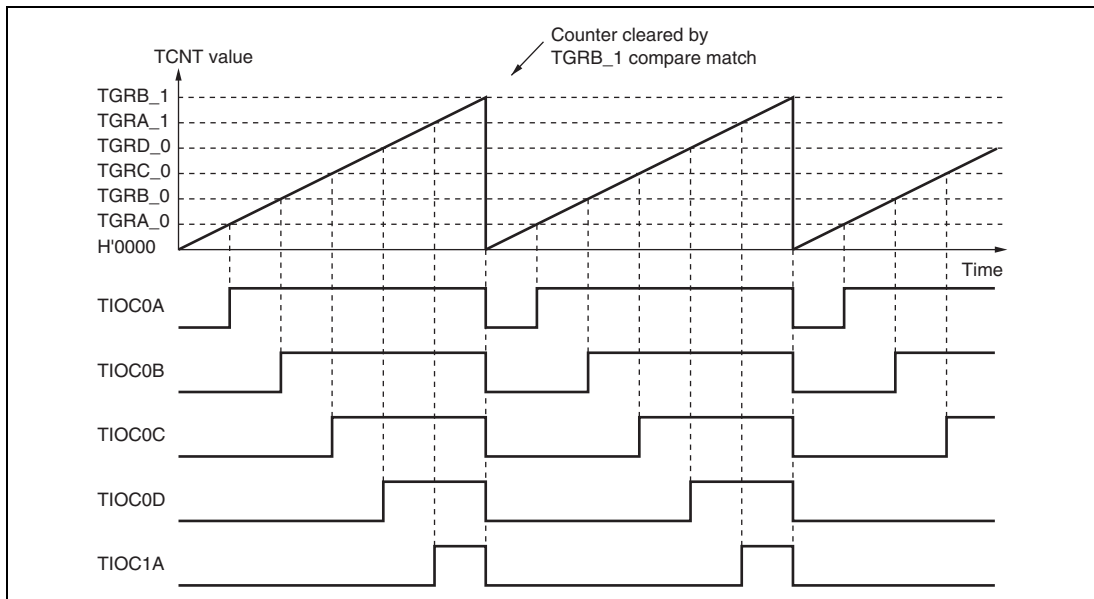


**Figure 9.26 Example of PWM Mode Operation (1)**

Figure 9.27 shows an example of PWM mode 2 operation in the SH7125.

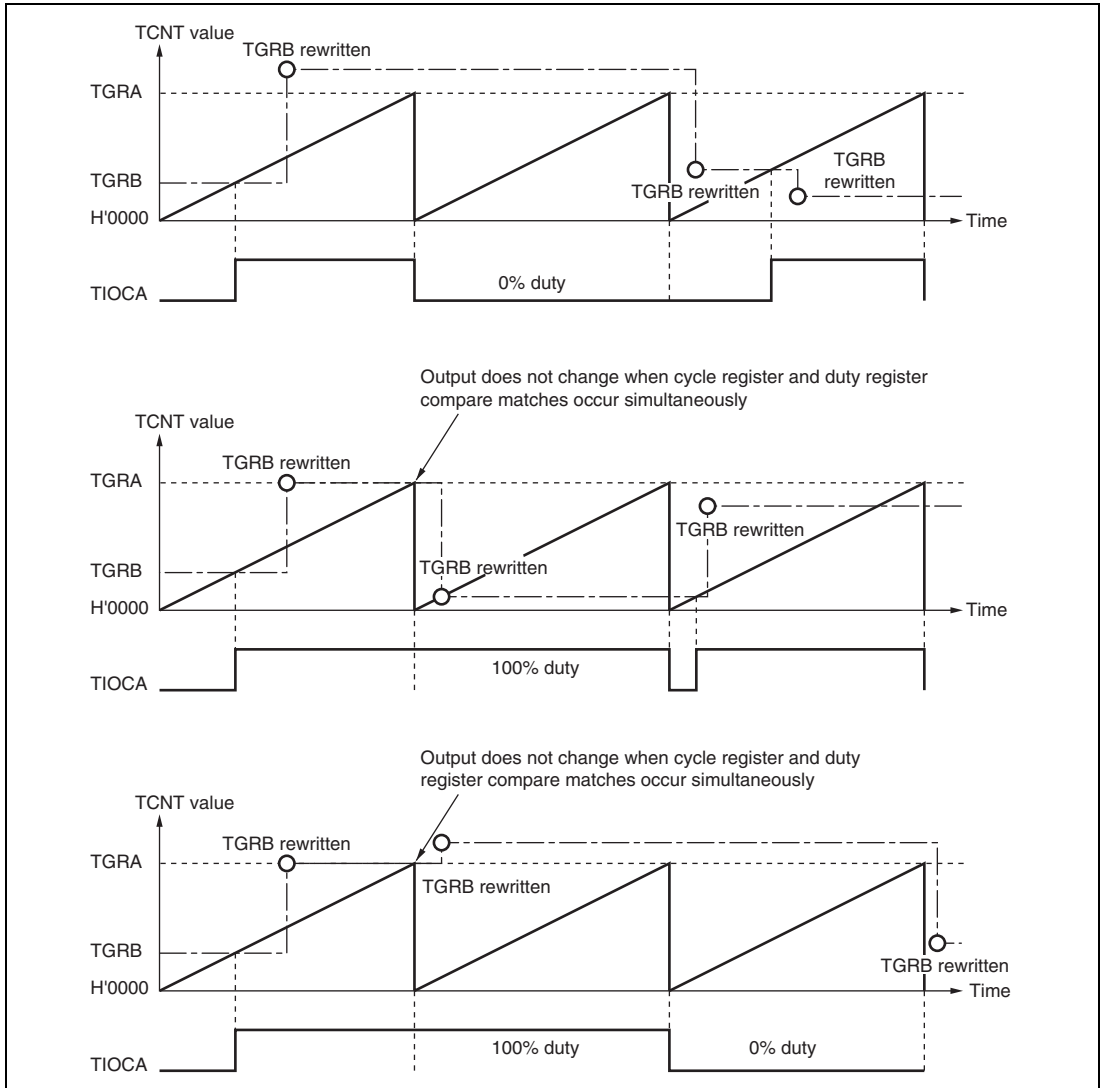
In this example, synchronous operation is designated for channels 0 and 1, TGRB\_1 compare match is set as the TCNT clearing source, and 0 is set for the initial output value and 1 for the output value of the other TGR registers (TGRA\_0 to TGRD\_0, TGRA\_1), outputting a 5-phase PWM waveform.

In this case, the value set in TGRB\_1 is used as the cycle, and the values set in the other TGRs are used as the duty levels.



**Figure 9.27 Example of PWM Mode Operation (2)**

Figure 9.28 shows examples of PWM waveform output with 0% duty and 100% duty in PWM mode.



**Figure 9.28 Example of PWM Mode Operation (3)**

### 9.4.6 Phase Counting Mode

In phase counting mode, the phase difference between two external clock inputs is detected and TCNT is incremented/decremented accordingly. This mode can be set for channels 1 and 2.

When phase counting mode is set, an external clock is selected as the counter input clock and TCNT operates as an up/down-counter regardless of the setting of bits TPSC0 to TPSC2 and bits CKEG0 and CKEG1 in TCR. However, the functions of bits CCLR0 and CCLR1 in TCR, and of TIOR, TIER, and TGR, are valid, and input capture/compare match and interrupt functions can be used.

This can be used for two-phase encoder pulse input.

If overflow occurs when TCNT is counting up, the TCFV flag in TSR is set; if underflow occurs when TCNT is counting down, the TCFU flag is set.

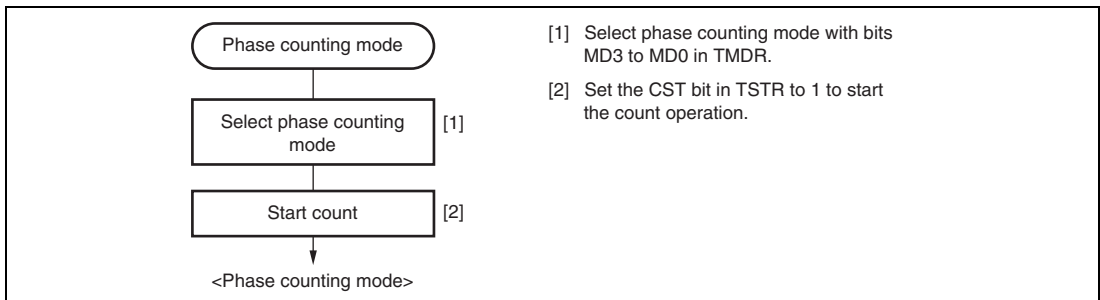
The TCFD bit in TSR is the count direction flag. Reading the TCFD flag reveals whether TCNT is counting up or down.

Table 9.47 shows the correspondence between external clock pins and channels.

**Table 9.47 Phase Counting Mode Clock Input Pins**

Channels	External Clock Pins	
	A-Phase	B-Phase
When channel 1 is set to phase counting mode	TCLKA	TCLKB
When channel 2 is set to phase counting mode	TCLKC	TCLKD

**Example of Phase Counting Mode Setting Procedure:** Figure 9.29 shows an example of the phase counting mode setting procedure.

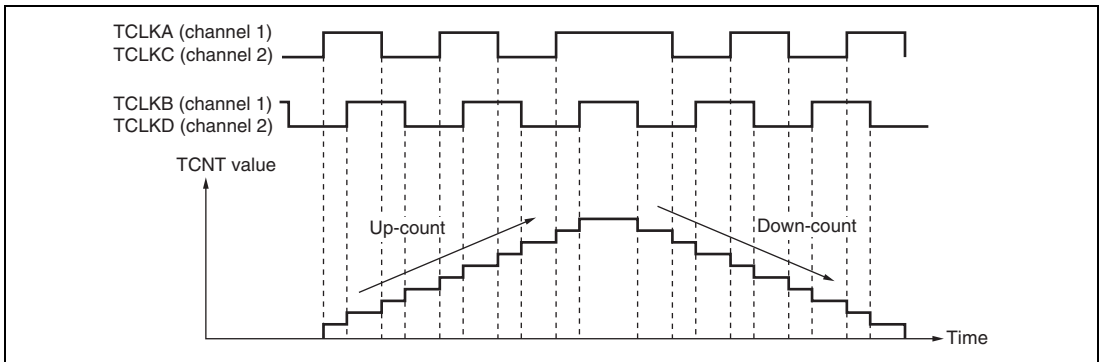


**Figure 9.29 Example of Phase Counting Mode Setting Procedure**

**Examples of Phase Counting Mode Operation:** In phase counting mode, TCNT counts up or down according to the phase difference between two external clocks. There are four modes, according to the count conditions.

### 1. Phase counting mode 1

Figure 9.30 shows an example of phase counting mode 1 operation, and table 9.48 summarizes the TCNT up/down-count conditions.



**Figure 9.30 Example of Phase Counting Mode 1 Operation**

**Table 9.48 Up/Down-Count Conditions in Phase Counting Mode 1**

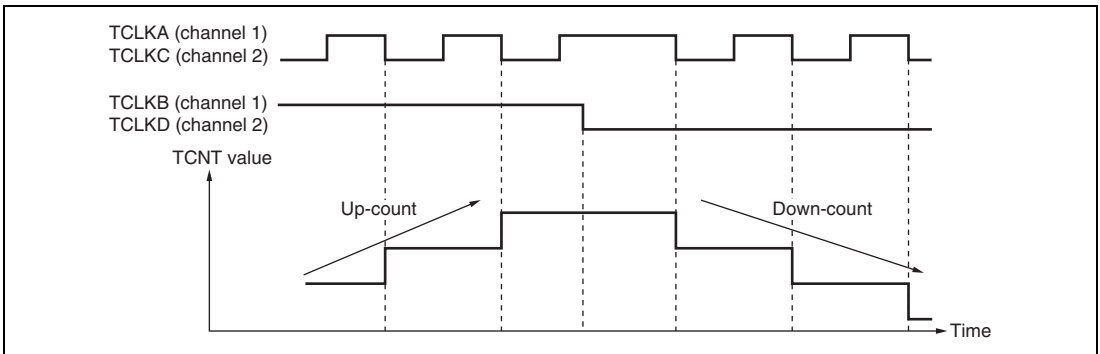
TCLKA (Channel 1) TCLKC (Channel 2)	TCLKB (Channel 1) TCLKD (Channel 2)	Operation
High level		Up-count
Low level		
	Low level	Down-count
	High level	
High level		Down-count
Low level		
	High level	Up-count
	Low level	

[Legend]

: Rising edge  
: Falling edge

## 2. Phase counting mode 2

Figure 9.31 shows an example of phase counting mode 2 operation, and table 9.49 summarizes the TCNT up/down-count conditions.



**Figure 9.31 Example of Phase Counting Mode 2 Operation**

**Table 9.49 Up/Down-Count Conditions in Phase Counting Mode 2**

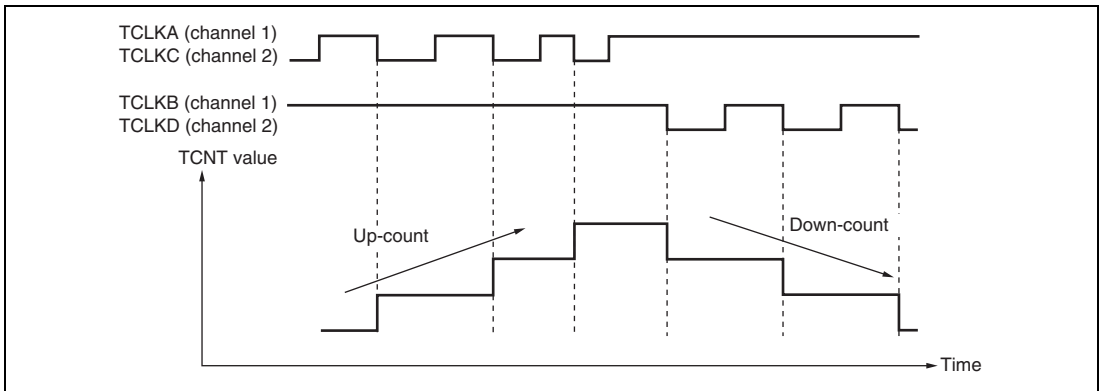
TCLKA (Channel 1) TCLKC (Channel 2)	TCLKB (Channel 1) TCLKD (Channel 2)	Operation
High level		Don't care
Low level		Don't care
	Low level	Don't care
	High level	Up-count
High level		Don't care
Low level		Don't care
	High level	Don't care
	Low level	Down-count

[Legend]

: Rising edge  
: Falling edge

## 3. Phase counting mode 3

Figure 9.32 shows an example of phase counting mode 3 operation, and table 9.50 summarizes the TCNT up/down-count conditions.



**Figure 9.32 Example of Phase Counting Mode 3 Operation**

**Table 9.50 Up/Down-Count Conditions in Phase Counting Mode 3**

TCLKA (Channel 1) TCLKC (Channel 2)	TCLKB (Channel 1) TCLKD (Channel 2)	Operation
High level		Don't care
Low level		Don't care
	Low level	Don't care
	High level	Up-count
High level		Down-count
Low level		Don't care
	High level	Don't care
	Low level	Don't care

[Legend]

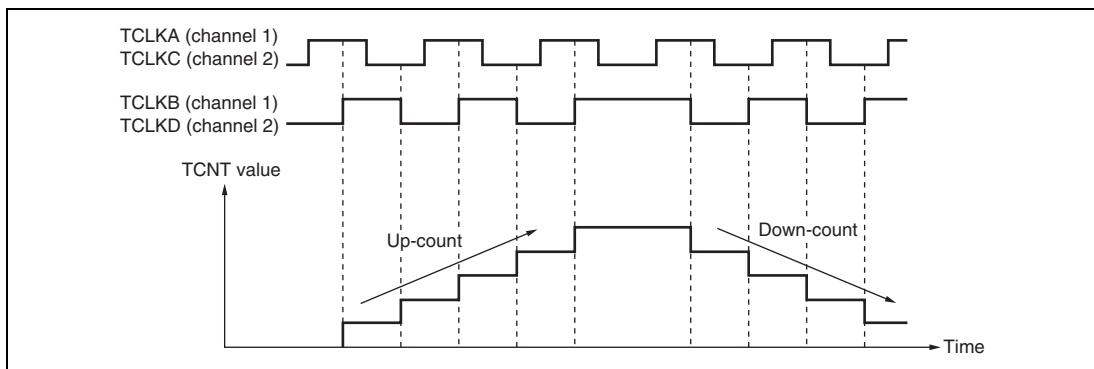
: Rising edge

: Falling edge



## 4. Phase counting mode 4

Figure 9.33 shows an example of phase counting mode 4 operation, and table 9.51 summarizes the TCNT up/down-count conditions.



**Figure 9.33 Example of Phase Counting Mode 4 Operation**

**Table 9.51 Up/Down-Count Conditions in Phase Counting Mode 4**

TCLKA (Channel 1) TCLKC (Channel 2)	TCLKB (Channel 1) TCLKD (Channel 2)	Operation
High level		Up-count
Low level		Up-count
	Low level	Don't care
	High level	Don't care
High level		Down-count
Low level		Down-count
	High level	Don't care
	Low level	Don't care

[Legend]

: Rising edge

: Falling edge

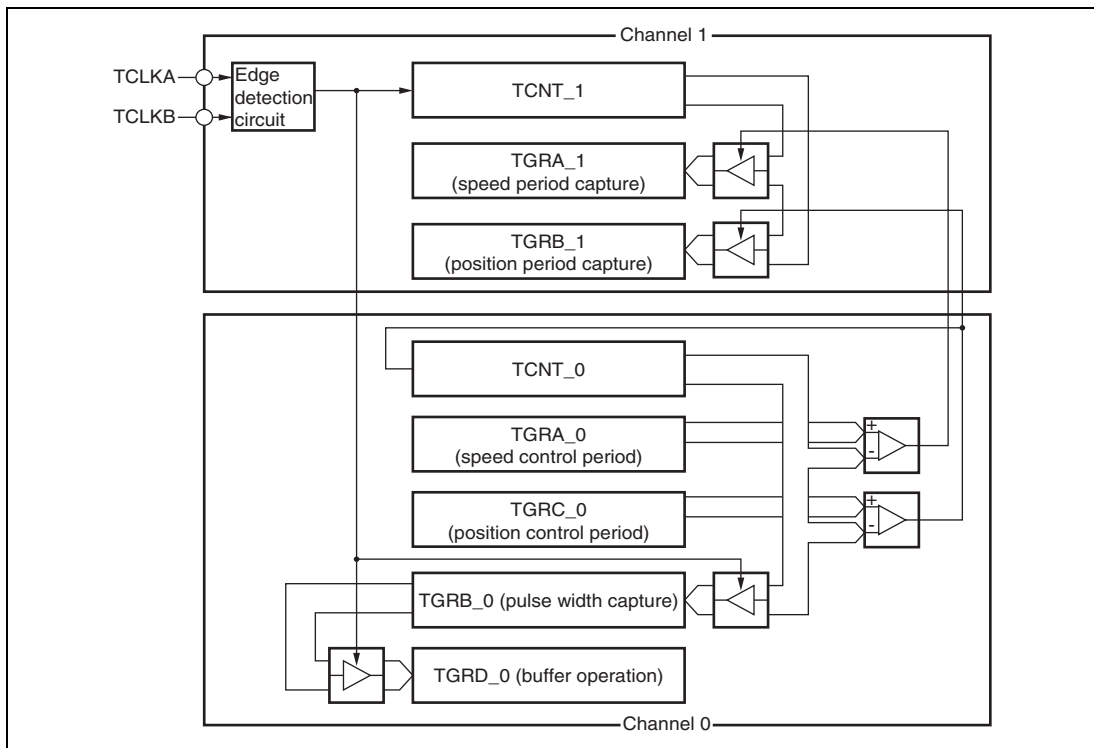
**Phase Counting Mode Application Example:** Figure 9.34 shows an example in which channel 1 is in phase counting mode, and channel 1 is coupled with channel 0 to input servo motor 2-phase encoder pulses in order to detect position or speed.

Channel 1 is set to phase counting mode 1, and the encoder pulse A-phase and B-phase are input to TCLKA and TCLKB.

Channel 0 operates with TCNT counter clearing by TGRC\_0 compare match; TGRA\_0 and TGRC\_0 are used for the compare match function and are set with the speed control period and position control period. TGRB\_0 is used for input capture, with TGRB\_0 and TGRD\_0 operating in buffer mode. The channel 1 counter input clock is designated as the TGRB\_0 input capture source, and the pulse widths of 2-phase encoder 4-multiplication pulses are detected.

TGRA\_1 and TGRB\_1 for channel 1 are designated for input capture, and channel 0 TGRA\_0 and TGRC\_0 compare matches are selected as the input capture source and store the up/down-counter values for the control periods.

This procedure enables the accurate detection of position and speed.



**Figure 9.34 Phase Counting Mode Application Example**

### 9.4.7 Reset-Synchronized PWM Mode

In the reset-synchronized PWM mode, three-phase output of positive and negative PWM waveforms that share a common wave transition point can be obtained by combining channels 3 and 4.

When set for reset-synchronized PWM mode, the TIOC3B, TIOC3D, TIOC4A, TIOC4C, TIOC4B, and TIOC4D pins function as PWM output pins and TCNT\_3 functions as an upcounter.

Table 9.52 shows the PWM output pins used. Table 9.53 shows the settings of the registers.

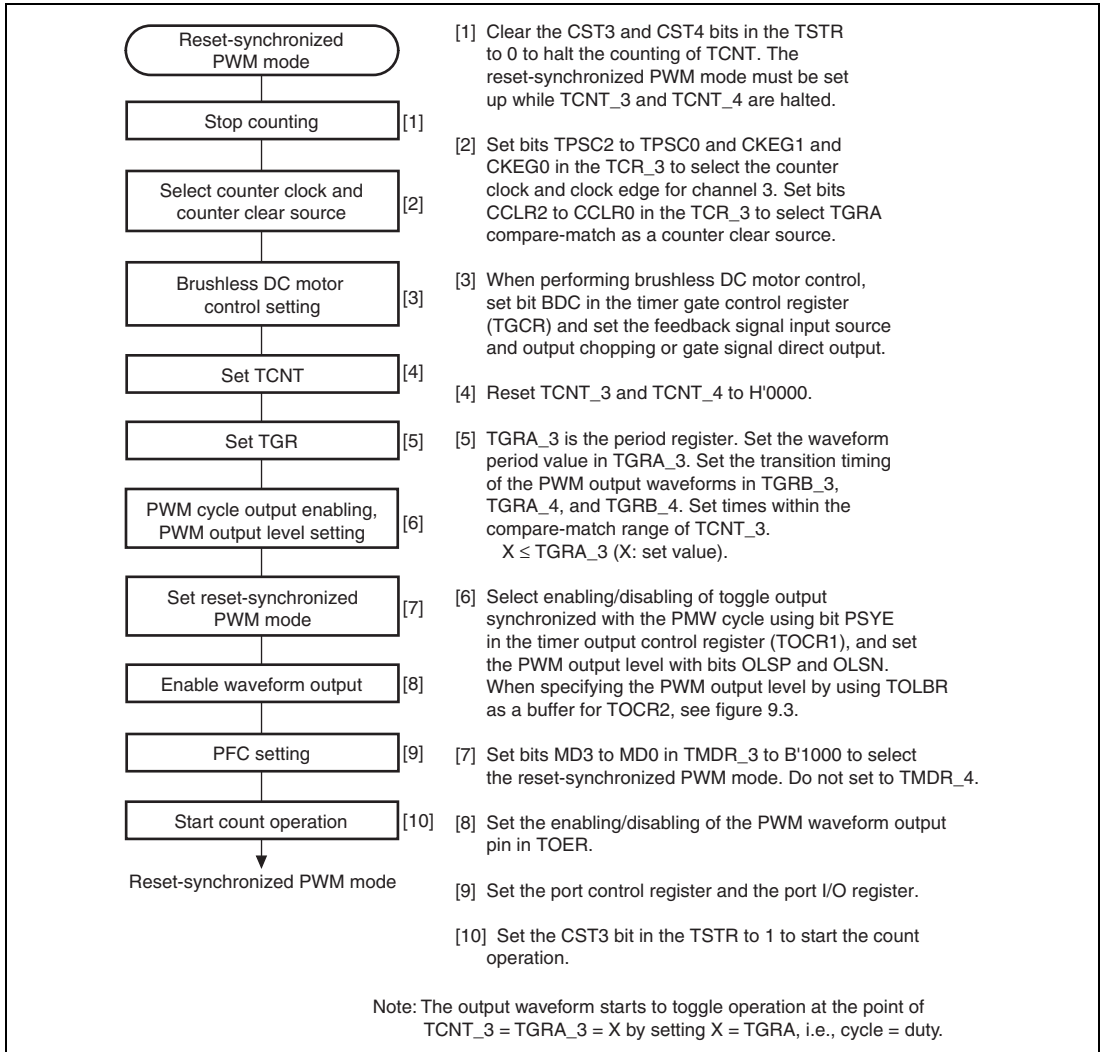
**Table 9.52 Output Pins for Reset-Synchronized PWM Mode**

Channel	Output Pin	Description
3	TIOC3B	PWM output pin 1
	TIOC3D	PWM output pin 1' (negative-phase waveform of PWM output 1)
4	TIOC4A	PWM output pin 2
	TIOC4C	PWM output pin 2' (negative-phase waveform of PWM output 2)
	TIOC4B	PWM output pin 3
	TIOC4D	PWM output pin 3' (negative-phase waveform of PWM output 3)

**Table 9.53 Register Settings for Reset-Synchronized PWM Mode**

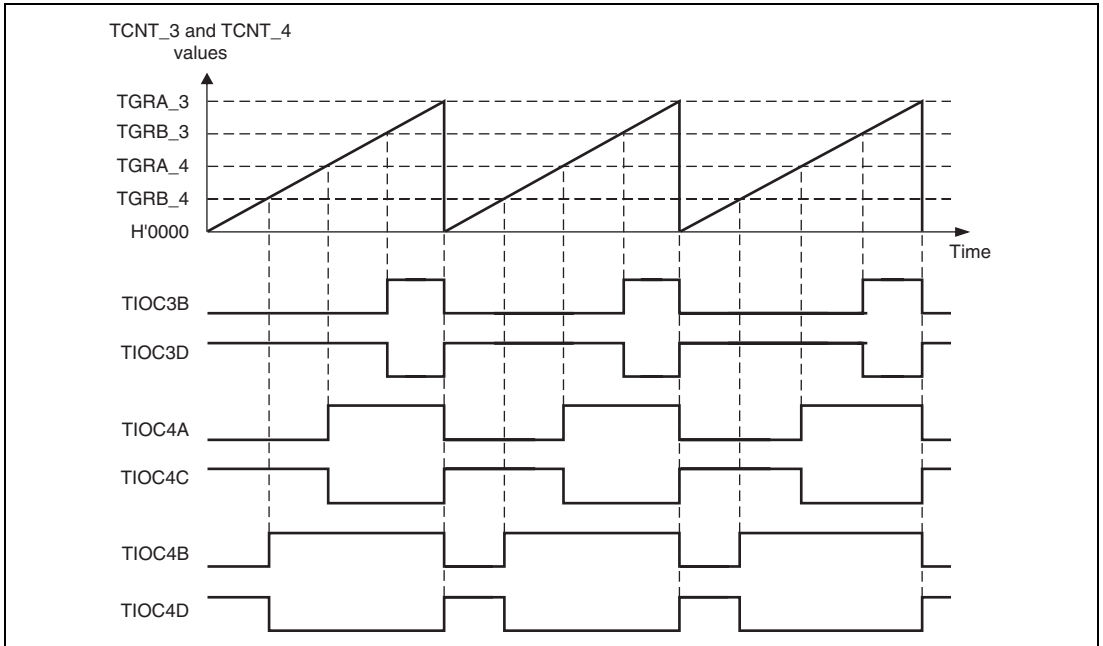
Register	Description of Setting
TCNT_3	Initial setting of H'0000
TCNT_4	Initial setting of H'0000
TGRA_3	Set count cycle for TCNT_3
TGRB_3	Sets the turning point for PWM waveform output by the TIOC3B and TIOC3D pins
TGRA_4	Sets the turning point for PWM waveform output by the TIOC4A and TIOC4C pins
TGRB_4	Sets the turning point for PWM waveform output by the TIOC4B and TIOC4D pins

**Procedure for Selecting the Reset-Synchronized PWM Mode:** Figure 9.35 shows an example of procedure for selecting the reset synchronized PWM mode.



**Figure 9.35 Procedure for Selecting Reset-Synchronized PWM Mode**

**Reset-Synchronized PWM Mode Operation:** Figure 9.36 shows an example of operation in the reset-synchronized PWM mode. TCNT\_3 and TCNT\_4 operate as upcounters. The counter is cleared when a TCNT\_3 and TGRA\_3 compare-match occurs, and then begins incrementing from H'0000. The PWM output pin output toggles with each occurrence of a TGRB\_3, TGRA\_4, TGRB\_4 compare-match, and upon counter clears.



**Figure 9.36 Reset-Synchronized PWM Mode Operation Example  
(When TOCR's OLSN = 1 and OLSP = 1)**

### 9.4.8 Complementary PWM Mode

In the complementary PWM mode, three-phase output of non-overlapping positive and negative PWM waveforms can be obtained by combining channels 3 and 4. PWM waveforms without non-overlapping interval is also available.

In complementary PWM mode, TIOC3B, TIOC3D, TIOC4A, TIOC4B, TIOC4C, and TIOC4D pins function as PWM output pins, the TIOC3A pin can be set for toggle output synchronized with the PWM period. TCNT\_3 and TCNT\_4 function as up/down counters.

Table 9.54 shows the PWM output pins used. Table 9.55 shows the settings of the registers used.

A function to directly cut off the PWM output by using an external signal is supported as a port function.

**Table 9.54 Output Pins for Complementary PWM Mode**

Channel	Output Pin	Description
3	TIOC3A	Toggle output synchronized with PWM period (or I/O port)
	TIOC3B	PWM output pin 1
	TIOC3C	I/O port*
	TIOC3D	PWM output pin 1' (non-overlapping negative-phase waveform of PWM output 1; PWM output without non-overlapping interval is also available)
4	TIOC4A	PWM output pin 2
	TIOC4B	PWM output pin 3
	TIOC4C	PWM output pin 2' (non-overlapping negative-phase waveform of PWM output 2; PWM output without non-overlapping interval is also available)
	TIOC4D	PWM output pin 3' (non-overlapping negative-phase waveform of PWM output 3; PWM output without non-overlapping interval is also available)

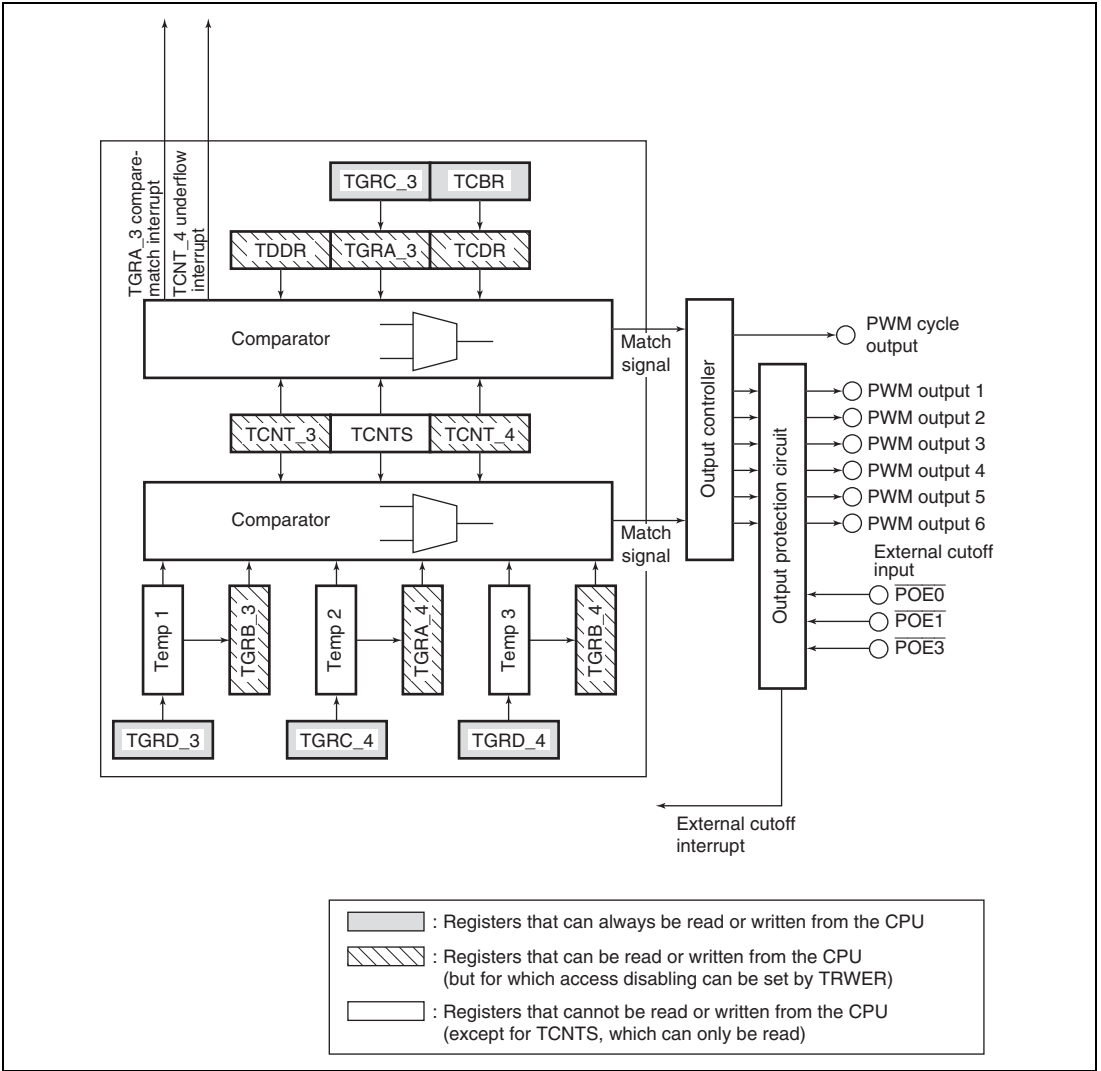
Note: \* Avoid setting the TIOC3C pin as a timer I/O pin in the complementary PWM mode.

**Table 9.55 Register Settings for Complementary PWM Mode**

Channel	Counter/Register	Description	Read/Write from CPU
3	TCNT_3	Start of up-count from value set in dead time register	Maskable by TRWER setting*
	TGRA_3	Set TCNT_3 upper limit value (1/2 carrier cycle + dead time)	Maskable by TRWER setting*
	TGRB_3	PWM output 1 compare register	Maskable by TRWER setting*
	TGRC_3	TGRA_3 buffer register	Always readable/writable
	TGRD_3	PWM output 1/TGRB_3 buffer register	Always readable/writable
4	TCNT_4	Up-count start, initialized to H'0000	Maskable by TRWER setting*
	TGRA_4	PWM output 2 compare register	Maskable by TRWER setting*
	TGRB_4	PWM output 3 compare register	Maskable by TRWER setting*
	TGRC_4	PWM output 2/TGRA_4 buffer register	Always readable/writable
	TGRD_4	PWM output 3/TGRB_4 buffer register	Always readable/writable
Timer dead time data register (TDDR)	Set TCNT_4 and TCNT_3 offset value (dead time value)	Maskable by TRWER setting*	
Timer cycle data register (TCDR)	Set TCNT_4 upper limit value (1/2 carrier cycle)	Maskable by TRWER setting*	
Timer cycle buffer register (TCBR)	TCDR buffer register	Always readable/writable	
Subcounter (TCNTS)	Subcounter for dead time generation	Read-only	
Temporary register 1 (TEMP1)	PWM output 1/TGRB_3 temporary register	Not readable/writable	
Temporary register 2 (TEMP2)	PWM output 2/TGRA_4 temporary register	Not readable/writable	
Temporary register 3 (TEMP3)	PWM output 3/TGRB_4 temporary register	Not readable/writable	

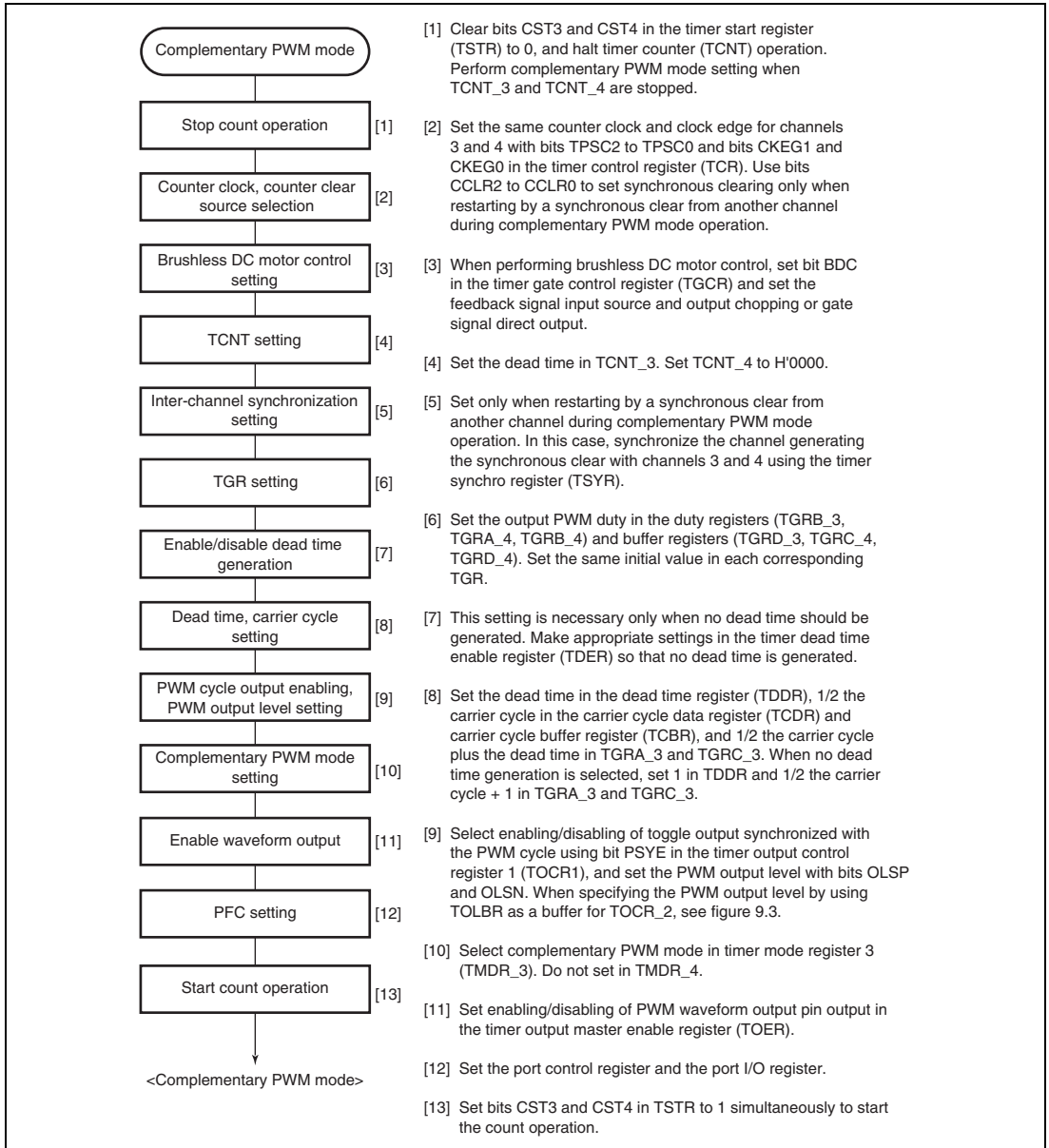
Note: \* Access can be enabled or disabled according to the setting of bit 0 (RWE) in TRWER (timer read/write enable register).





**Figure 9.37 Block Diagram of Channels 3 and 4 in Complementary PWM Mode**

**Example of Complementary PWM Mode Setting Procedure:** An example of the complementary PWM mode setting procedure is shown in figure 9.38.



**Figure 9.38 Example of Complementary PWM Mode Setting Procedure**

## Outline of Complementary PWM Mode Operation:

In complementary PWM mode, 6-phase PWM output is possible. Figure 9.39 illustrates counter operation in complementary PWM mode, and figure 9.40 shows an example of complementary PWM mode operation.

### 1. Counter Operation

In complementary PWM mode, three counters—TCNT\_3, TCNT\_4, and TCNTS—perform up/down-count operations.

TCNT\_3 is automatically initialized to the value set in TDDR when complementary PWM mode is selected and the CST bit in TSTR is 0.

When the CST bit is set to 1, TCNT\_3 counts up to the value set in TGRA\_3, then switches to down-counting when it matches TGRA\_3. When the TCNT3 value matches TDDR, the counter switches to up-counting, and the operation is repeated in this way.

TCNT\_4 is initialized to H'0000.

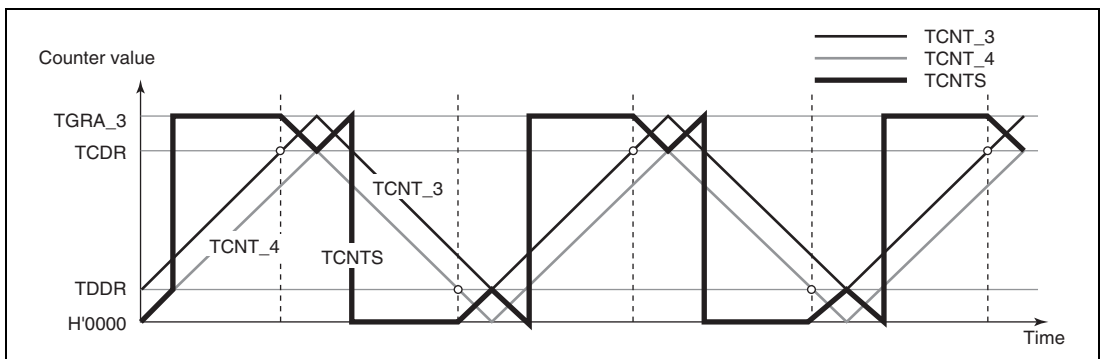
When the CST bit is set to 1, TCNT\_4 counts up in synchronization with TCNT\_3, and switches to down-counting when it matches TCDR. On reaching H'0000, TCNT4 switches to up-counting, and the operation is repeated in this way.

TCNTS is a read-only counter. It need not be initialized.

When TCNT\_3 matches TCDR during TCNT\_3 and TCNT\_4 up/down-counting, down-counting is started, and when TCNTS matches TCDR, the operation switches to up-counting. When TCNTS matches TGRA\_3, it is cleared to H'0000.

When TCNT\_4 matches TDDR during TCNT\_3 and TCNT\_4 down-counting, up-counting is started, and when TCNTS matches TDDR, the operation switches to down-counting. When TCNTS reaches H'0000, it is set with the value in TGRA\_3.

TCNTS is compared with the compare register and temporary register in which the PWM duty is set during the count operation only.



**Figure 9.39 Complementary PWM Mode Counter Operation**

## 2. Register Operation

In complementary PWM mode, nine registers are used, comprising compare registers, buffer registers, and temporary registers. Figure 9.40 shows an example of complementary PWM mode operation.

The registers which are constantly compared with the counters to perform PWM output are TGRB\_3, TGRA\_4, and TGRB\_4. When these registers match the counter, the value set in bits OLSN and OLSP in the timer output control register (TOCR) is output.

The buffer registers for these compare registers are TGRD\_3, TGRC\_4, and TGRD\_4.

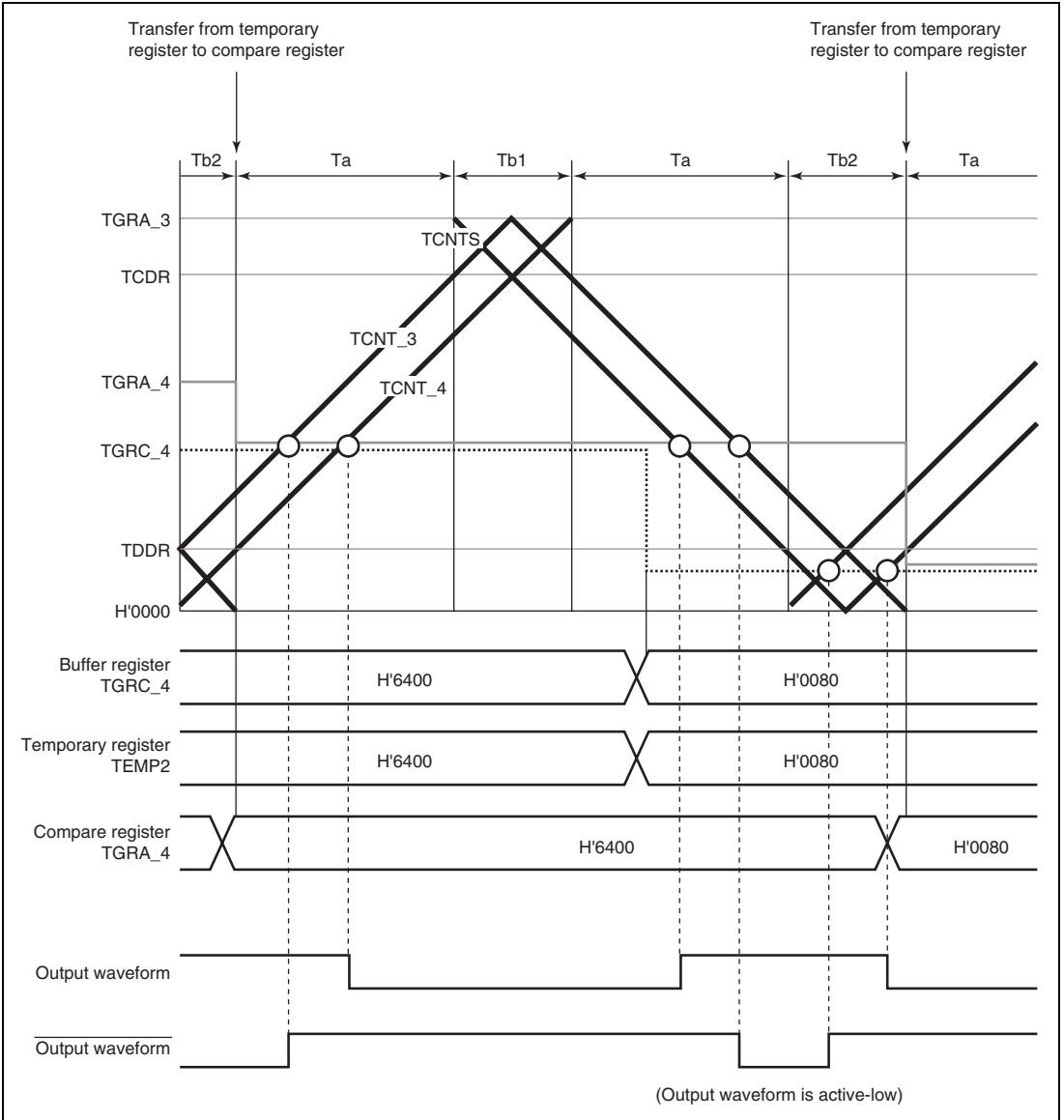
Between a buffer register and compare register there is a temporary register. The temporary registers cannot be accessed by the CPU.

Data in a compare register is changed by writing the new data to the corresponding buffer register. The buffer registers can be read or written at any time.

The data written to a buffer register is constantly transferred to the temporary register in the Ta interval. Data is not transferred to the temporary register in the Tb interval. Data written to a buffer register in this interval is transferred to the temporary register at the end of the Tb interval.

The value transferred to a temporary register is transferred to the compare register when TCNTS for which the Tb interval ends matches TGRA\_3 when counting up, or H'0000 when counting down. The timing for transfer from the temporary register to the compare register can be selected with bits MD3 to MD0 in the timer mode register (TMDR). Figure 9.40 shows an example in which the mode is selected in which the change is made in the trough.

In the Tb interval (Tb1 in figure 9.40) in which data transfer to the temporary register is not performed, the temporary register has the same function as the compare register, and is compared with the counter. In this interval, therefore, there are two compare match registers for one-phase output, with the compare register containing the pre-change data, and the temporary register containing the new data. In this interval, the three counters—TCNT\_3, TCNT\_4, and TCNTS—and two registers—compare register and temporary register—are compared, and PWM output controlled accordingly.



**Figure 9.40 Example of Complementary PWM Mode Operation**

### 3. Initialization

In complementary PWM mode, there are six registers that must be initialized. In addition, there is a register that specifies whether to generate dead time (it should be used only when dead time generation should be disabled).

Before setting complementary PWM mode with bits MD3 to MD0 in the timer mode register (TMDR), the following initial register values must be set.

TGRC\_3 operates as the buffer register for TGRA\_3, and should be set with 1/2 the PWM carrier cycle + dead time Td. The timer cycle buffer register (TCBR) operates as the buffer register for the timer cycle data register (TCDR), and should be set with 1/2 the PWM carrier cycle. Set dead time Td in the timer dead time data register (TDDR).

When dead time is not needed, the TDER bit in the timer dead time enable register (TDER) should be cleared to 0, TGRC\_3 and TGRA\_3 should be set to 1/2 the PWM carrier cycle + 1, and TDDR should be set to 1.

Set the respective initial PWM duty values in buffer registers TGRD\_3, TGRC\_4, and TGRD\_4.

The values set in the five buffer registers excluding TDDR are transferred simultaneously to the corresponding compare registers when complementary PWM mode is set.

Set TCNT\_4 to H'0000 before setting complementary PWM mode.

**Table 9.56 Registers and Counters Requiring Initialization**

Register/Counter	Set Value
TGRC_3	1/2 PWM carrier cycle + dead time Td (1/2 PWM carrier cycle + 1 when dead time generation is disabled by TDER)
TDDR	Dead time Td (1 when dead time generation is disabled by TDER)
TCBR	1/2 PWM carrier cycle
TGRD_3, TGRC_4, TGRD_4	Initial PWM duty value for each phase
TCNT_4	H'0000

Note: The TGRC\_3 set value must be the sum of 1/2 the PWM carrier cycle set in TCBR and dead time Td set in TDDR. When dead time generation is disabled by TDER, TGRC\_3 must be set to 1/2 the PWM carrier cycle + 1.

#### 4. PWM Output Level Setting

In complementary PWM mode, the PWM pulse output level is set with bits OLSN and OLSP in timer output control register 1 (TOCR1) or bits OLS1P to OLS3P and OLS1N to OLS3N in timer output control register 2 (TOCR2).

The output level can be set for each of the three positive phases and three negative phases of 6-phase output.

Complementary PWM mode should be cleared before setting or changing output levels.

#### 5. Dead Time Setting

In complementary PWM mode, PWM pulses are output with a non-overlapping relationship between the positive and negative phases. This non-overlap time is called the dead time.

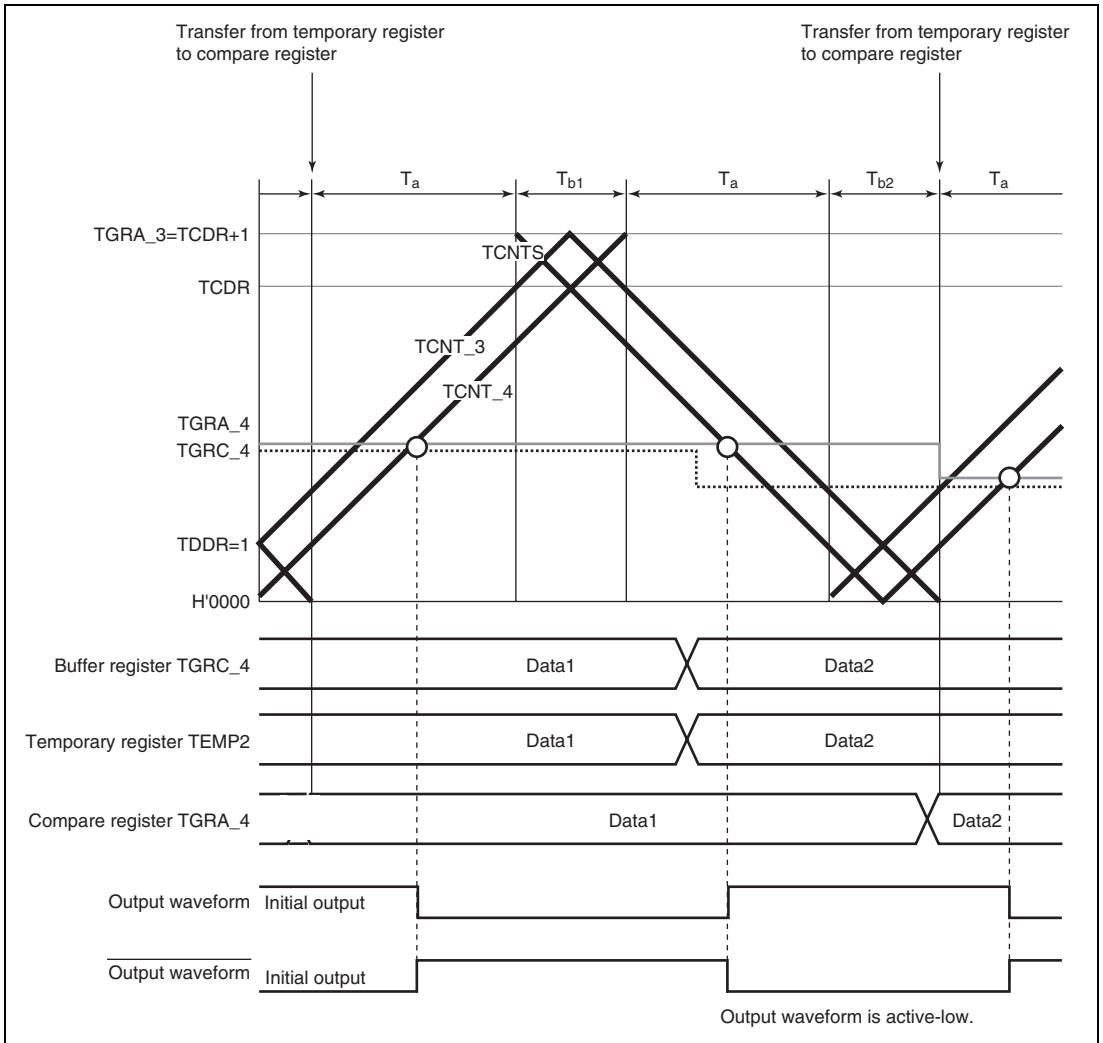
The non-overlap time is set in the timer dead time data register (TDDR). The value set in TDDR is used as the TCNT\_3 counter start value, and creates non-overlap between TCNT\_3 and TCNT\_4. Complementary PWM mode should be cleared before changing the contents of TDDR.

#### 6. Dead Time Suppressing

Dead time generation is suppressed by clearing the TDER bit in the timer dead time enable register (TDER) to 0. TDER can be cleared to 0 only when 0 is written to it after reading  $TDER = 1$ .

TGRA\_3 and TGRC\_3 should be set to  $1/2$  PWM carrier cycle + 1 and the timer dead time data register (TDDR) should be set to 1.

By the above settings, PWM waveforms without dead time can be obtained. Figure 9.41 shows an example of operation without dead time.



**Figure 9.41 Example of Operation without Dead Time**



## 7. PWM Cycle Setting

In complementary PWM mode, the PWM pulse cycle is set in two registers—TGRA\_3, in which the TCNT\_3 upper limit value is set, and TCDR, in which the TCNT\_4 upper limit value is set. The settings should be made so as to achieve the following relationship between these two registers:

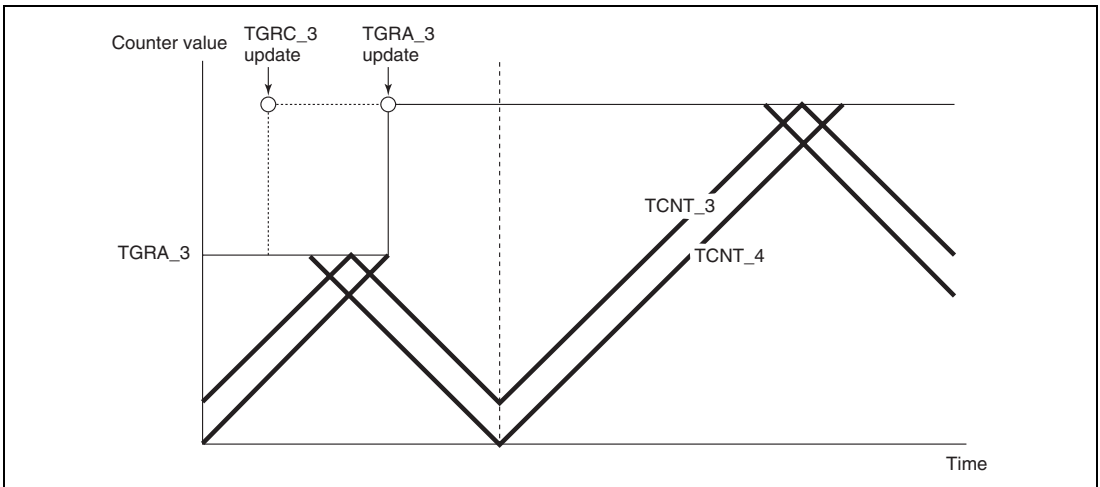
With dead time: TGRA\_3 set value = TCDR set value + TDDR set value

Without dead time: TGRA\_3 set value = TCDR set value + 1

The TGRA\_3 and TCDR settings are made by setting the values in buffer registers TGRC\_3 and TCBR. The values set in TGRC\_3 and TCBR are transferred simultaneously to TGRA\_3 and TCDR in accordance with the transfer timing selected with bits MD3 to MD0 in the timer mode register (TMDR).

The updated PWM cycle is reflected from the next cycle when the data update is performed at the crest, and from the current cycle when performed in the trough. Figure 9.42 illustrates the operation when the PWM cycle is updated at the crest.

See the following section, Register Data Updating, for the method of updating the data in each buffer register.



**Figure 9.42 Example of PWM Cycle Updating**

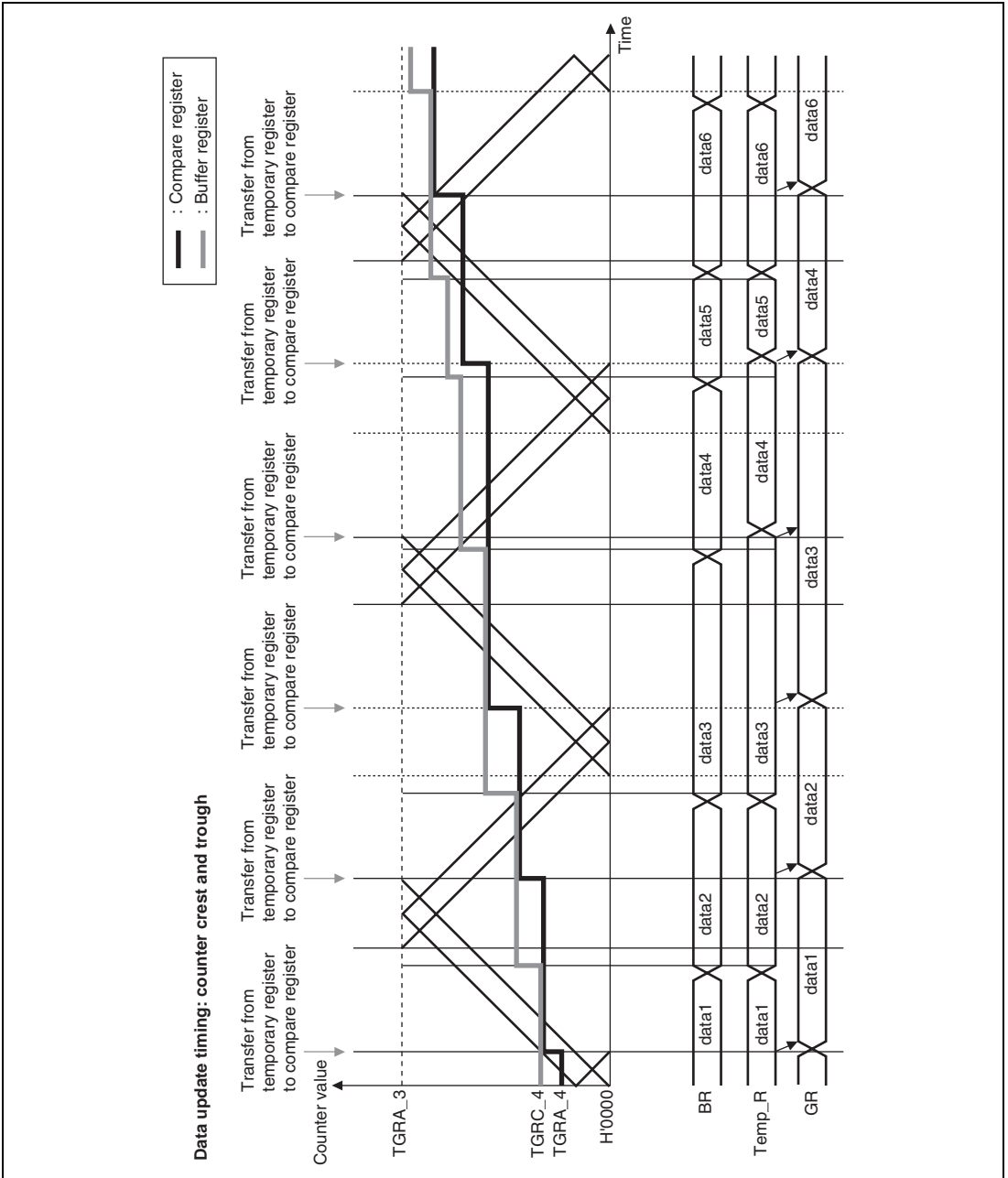
## 8. Register Data Updating

In complementary PWM mode, the buffer register is used to update the data in a compare register. The update data can be written to the buffer register at any time. There are five PWM duty and carrier cycle registers that have buffer registers and can be updated during operation. There is a temporary register between each of these registers and its buffer register. When subcounter TCNTS is not counting, if buffer register data is updated, the temporary register value is also rewritten. Transfer is not performed from buffer registers to temporary registers when TCNTS is counting; in this case, the value written to a buffer register is transferred after TCNTS halts.

The temporary register value is transferred to the compare register at the data update timing set with bits MD3 to MD0 in the timer mode register (TMDR). Figure 9.43 shows an example of data updating in complementary PWM mode. This example shows the mode in which data updating is performed at both the counter crest and trough.

When rewriting buffer register data, a write to TGRD\_4 must be performed at the end of the update. Data transfer from the buffer registers to the temporary registers is performed simultaneously for all five registers after the write to TGRD\_4.

A write to TGRD\_4 must be performed after writing data to the registers to be updated, even when not updating all five registers, or when updating the TGRD\_4 data. In this case, the data written to TGRD\_4 should be the same as the data prior to the write operation.



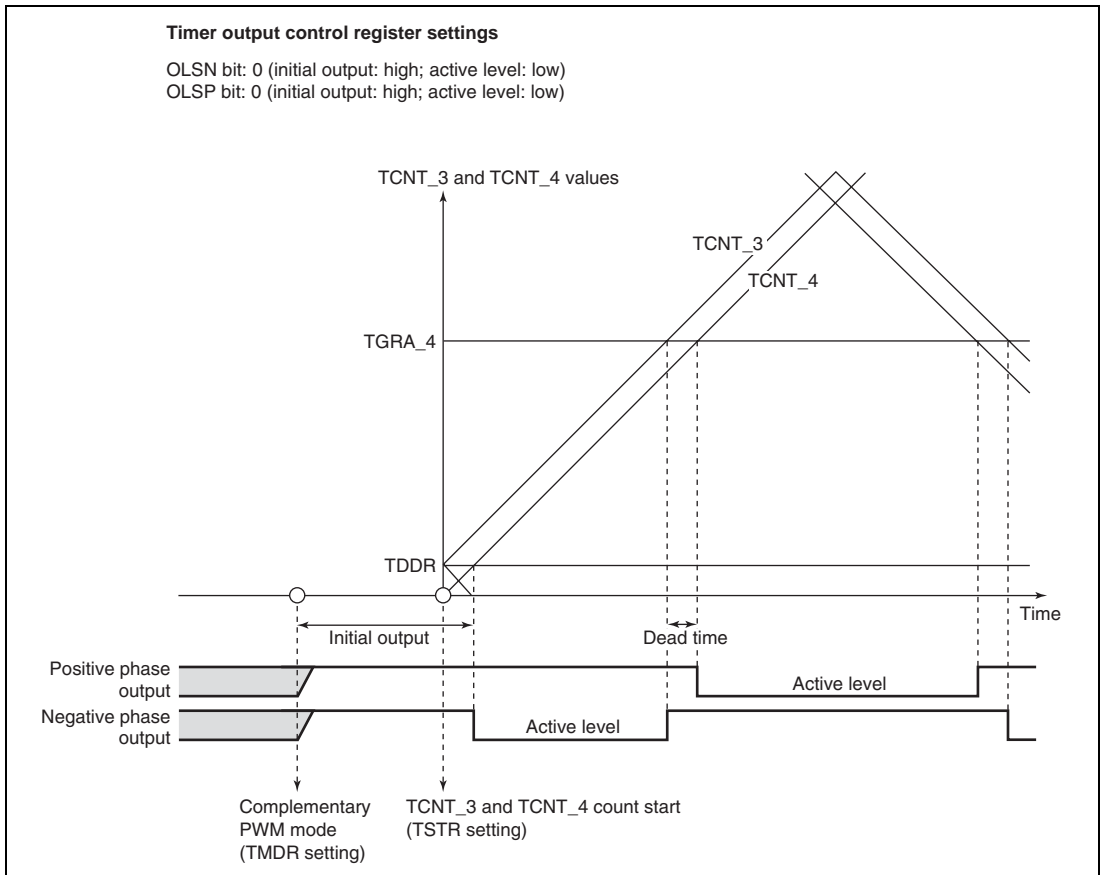
**Figure 9.43 Example of Data Update in Complementary PWM Mode**

## 9. Initial Output in Complementary PWM Mode

In complementary PWM mode, the initial output is determined by the setting of bits OLSN and OLSP in timer output control register 1 (TOCR1) or bits OLS1N to OLS3N and OLS1P to OLS3P in timer output control register 2 (TOCR2).

This initial output is the PWM pulse non-active level, and is output from when complementary PWM mode is set with the timer mode register (TMDR) until TCNT\_4 exceeds the value set in the dead time register (TDDR). Figure 9.44 shows an example of the initial output in complementary PWM mode.

An example of the waveform when the initial PWM duty value is smaller than the TDDR value is shown in figure 9.45.

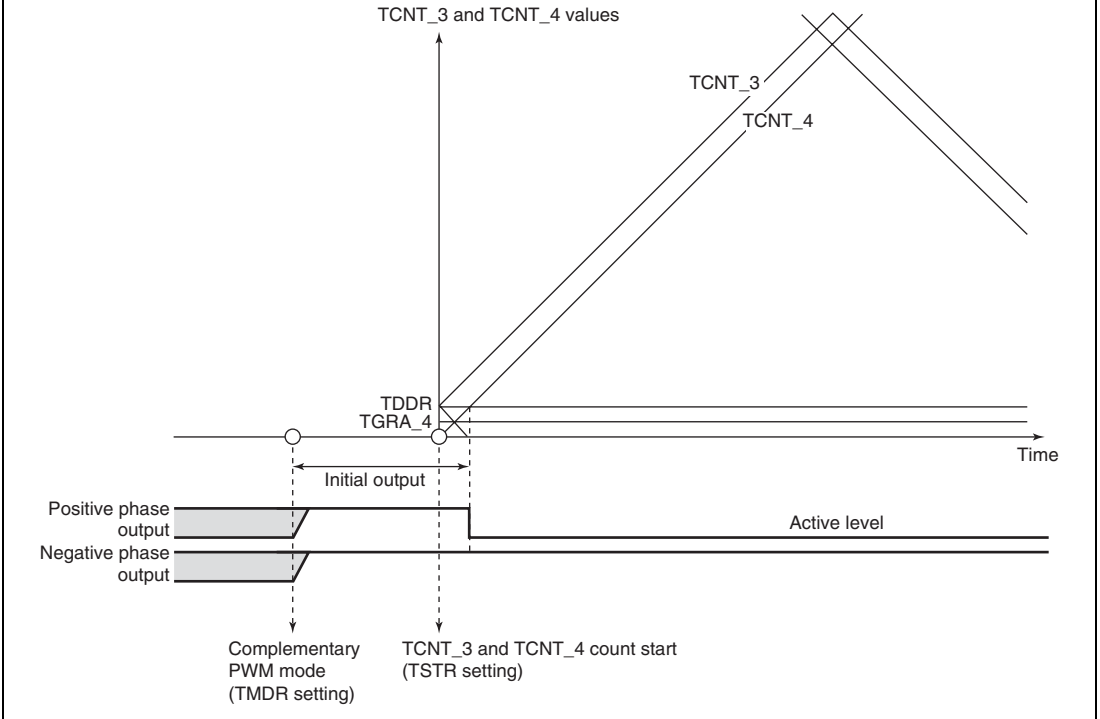


**Figure 9.44 Example of Initial Output in Complementary PWM Mode (1)**

**Timer output control register settings**

OLSN bit: 0 (initial output: high; active level: low)

OLSP bit: 0 (initial output: high; active level: low)

**Figure 9.45 Example of Initial Output in Complementary PWM Mode (2)**

## 10. Complementary PWM Mode PWM Output Generation Method

In complementary PWM mode, 3-phase output is performed of PWM waveforms with a non-overlap time between the positive and negative phases. This non-overlap time is called the dead time.

A PWM waveform is generated by output of the output level selected in the timer output control register in the event of a compare-match between a counter and data register. While TCNTS is counting, data register and temporary register values are simultaneously compared to create consecutive PWM pulses from 0 to 100%. The relative timing of on and off compare-match occurrence may vary, but the compare-match that turns off each phase takes precedence to secure the dead time and ensure that the positive phase and negative phase on times do not overlap. Figures 9.46 to 9.48 show examples of waveform generation in complementary PWM mode.

The positive phase/negative phase off timing is generated by a compare-match with the solid-line counter, and the on timing by a compare-match with the dotted-line counter operating with a delay of the dead time behind the solid-line counter. In the T1 period, compare-match **a** that turns off the negative phase has the highest priority, and compare-matches occurring prior to **a** are ignored. In the T2 period, compare-match **c** that turns off the positive phase has the highest priority, and compare-matches occurring prior to **c** are ignored.

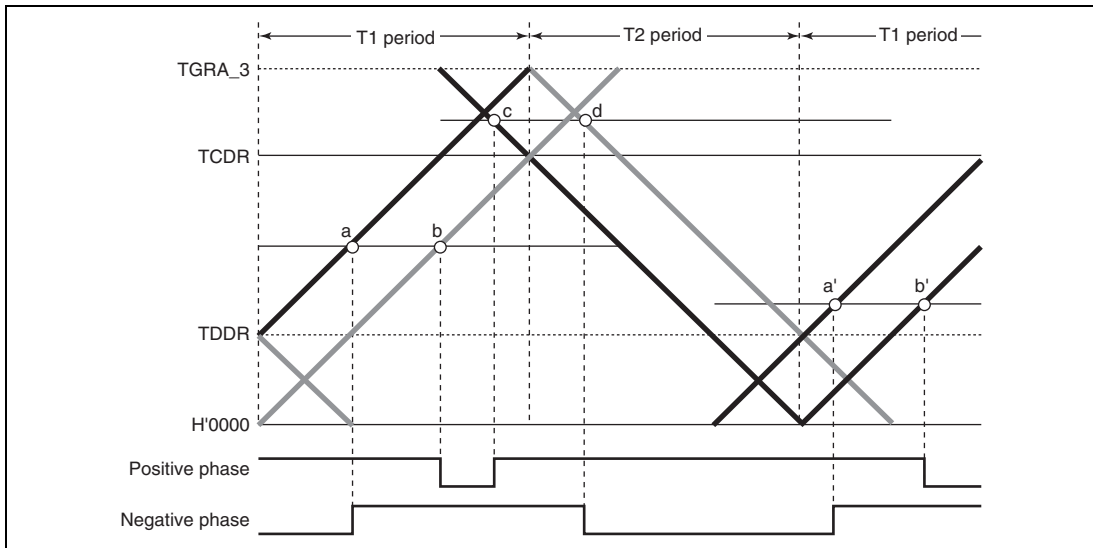
In normal cases, compare-matches occur in the order **a** → **b** → **c** → **d** (or **c** → **d** → **a'** → **b'**), as shown in figure 9.46.

If compare-matches deviate from the **a** → **b** → **c** → **d** order, since the time for which the negative phase is off is less than twice the dead time, the figure shows the positive phase is not being turned on. If compare-matches deviate from the **c** → **d** → **a'** → **b'** order, since the time for which the positive phase is off is less than twice the dead time, the figure shows the negative phase is not being turned on.

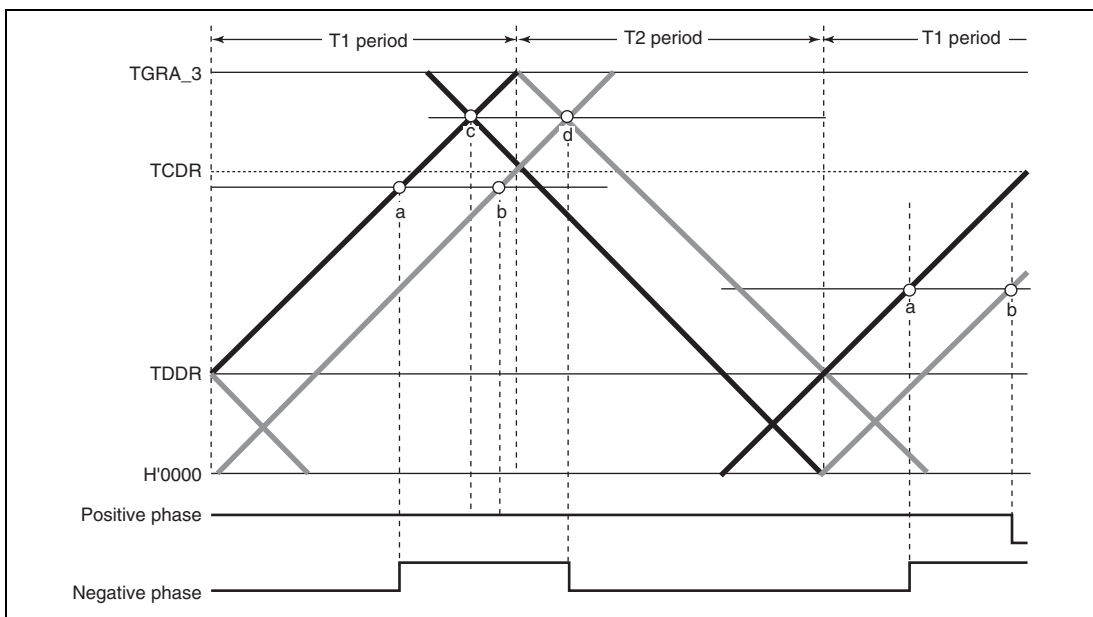
If compare-match **c** occurs first following compare-match **a**, as shown in figure 9.47, compare-match **b** is ignored, and the negative phase is turned off by compare-match **d**. This is because turning off of the positive phase has priority due to the occurrence of compare-match **c** (positive phase off timing) before compare-match **b** (positive phase on timing) (consequently, the waveform does not change since the positive phase goes from off to off).

Similarly, in the example in figure 9.48, compare-match **a'** with the new data in the temporary register occurs before compare-match **c**, but other compare-matches occurring up to **c**, which turns off the positive phase, are ignored. As a result, the negative phase is not turned on.

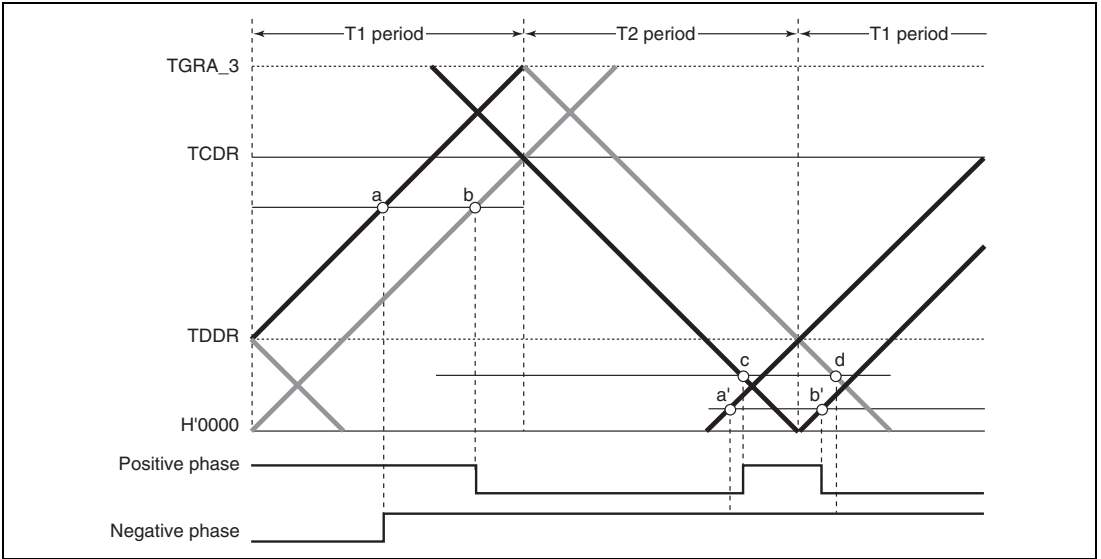
Thus, in complementary PWM mode, compare-matches at turn-off timings take precedence, and turn-on timing compare-matches that occur before a turn-off timing compare-match are ignored.



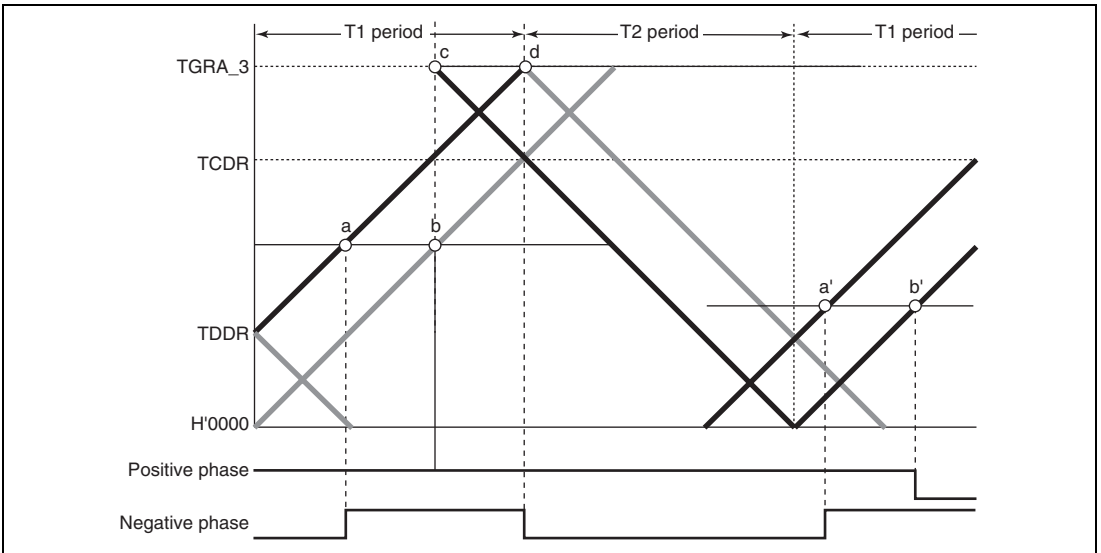
**Figure 9.46 Example of Complementary PWM Mode Waveform Output (1)**



**Figure 9.47 Example of Complementary PWM Mode Waveform Output (2)**

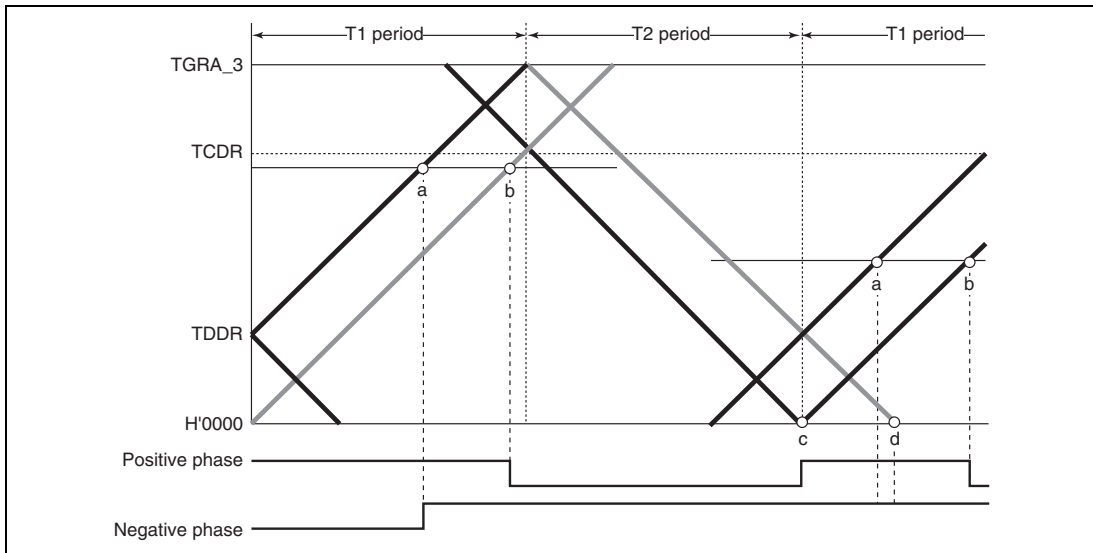


**Figure 9.48 Example of Complementary PWM Mode Waveform Output (3)**

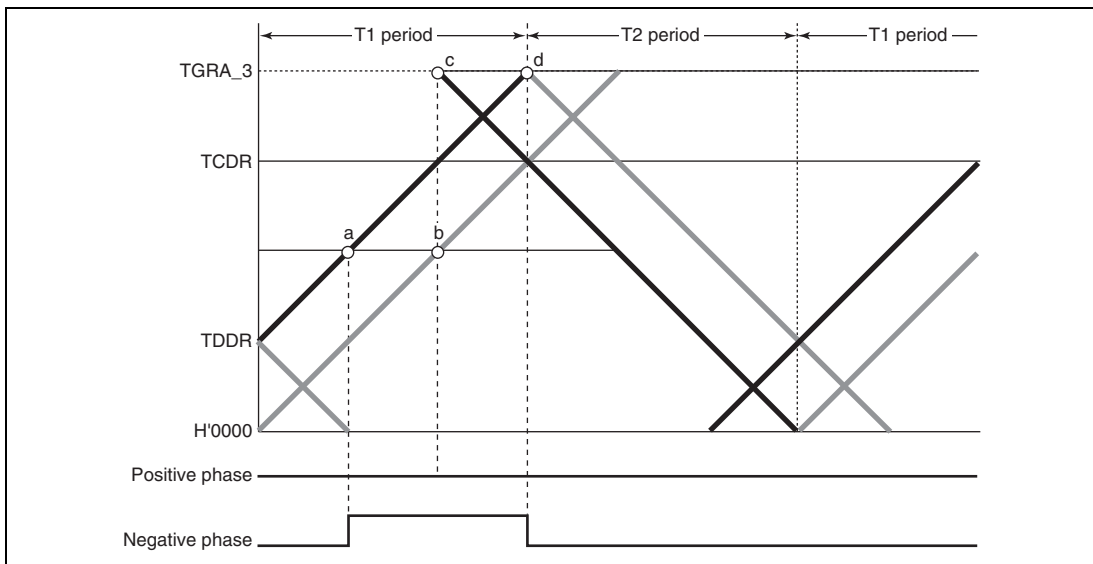


**Figure 9.49 Example of Complementary PWM Mode 0% and 100% Waveform Output (1)**

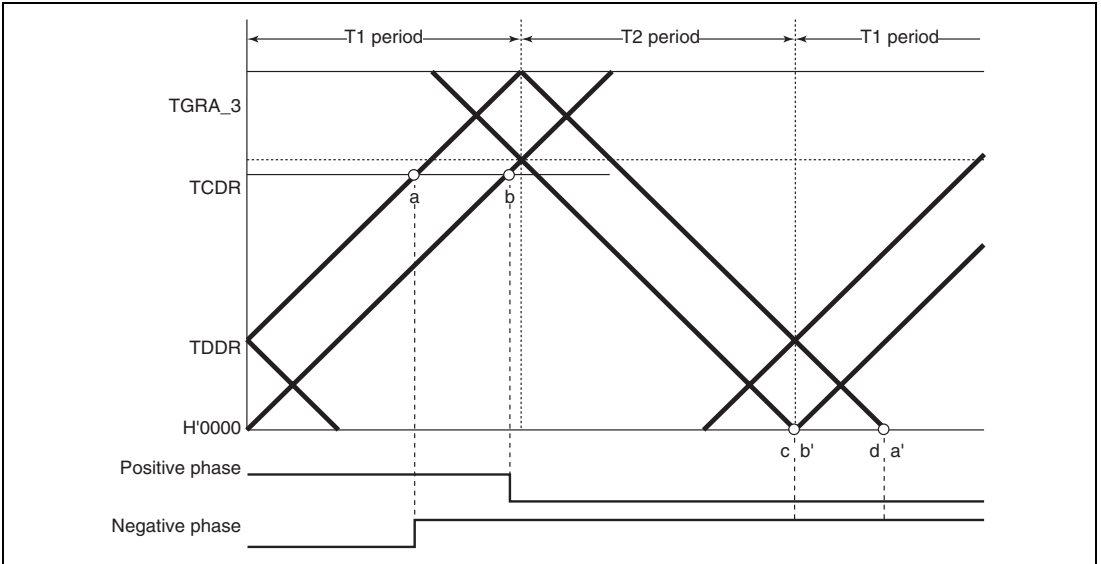




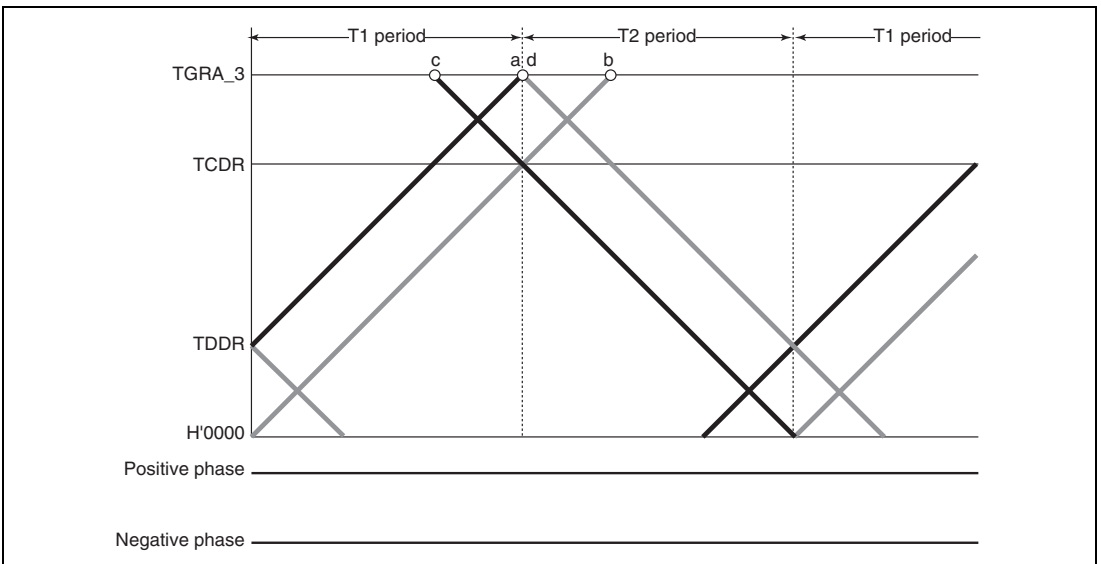
**Figure 9.50 Example of Complementary PWM Mode 0% and 100% Waveform Output (2)**



**Figure 9.51 Example of Complementary PWM Mode 0% and 100% Waveform Output (3)**



**Figure 9.52 Example of Complementary PWM Mode 0% and 100% Waveform Output (4)**



**Figure 9.53 Example of Complementary PWM Mode 0% and 100% Waveform Output (5)**

### 11. Complementary PWM Mode 0% and 100% Duty Output

In complementary PWM mode, 0% and 100% duty cycles can be output as required. Figures 9.49 to 9.53 show output examples.

100% duty output is performed when the data register value is set to H'0000. The waveform in this case has a positive phase with a 100% on-state. 0% duty output is performed when the data register value is set to the same value as TGRA\_3. The waveform in this case has a positive phase with a 100% off-state.

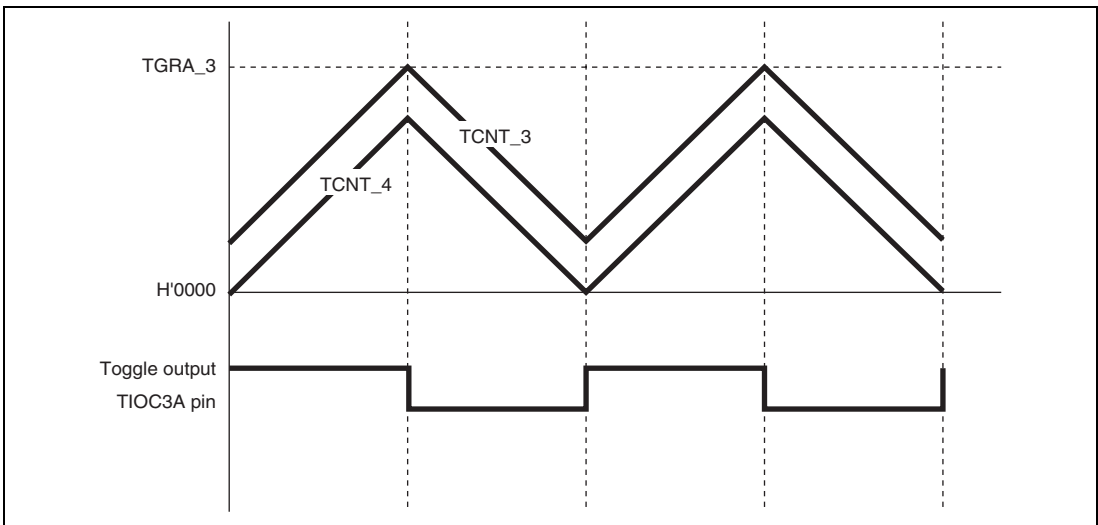
On and off compare-matches occur simultaneously, but if a turn-on compare-match and turn-off compare-match for the same phase occur simultaneously, both compare-matches are ignored and the waveform does not change.

### 12. Toggle Output Synchronized with PWM Cycle

In complementary PWM mode, toggle output can be performed in synchronization with the PWM carrier cycle by setting the PSYE bit to 1 in the timer output control register (TOCR). An example of a toggle output waveform is shown in figure 9.54.

This output is toggled by a compare-match between TCNT\_3 and TGRA\_3 and a compare-match between TCNT4 and H'0000.

The output pin for this toggle output is the TIOC3A pin. The initial output is 1.



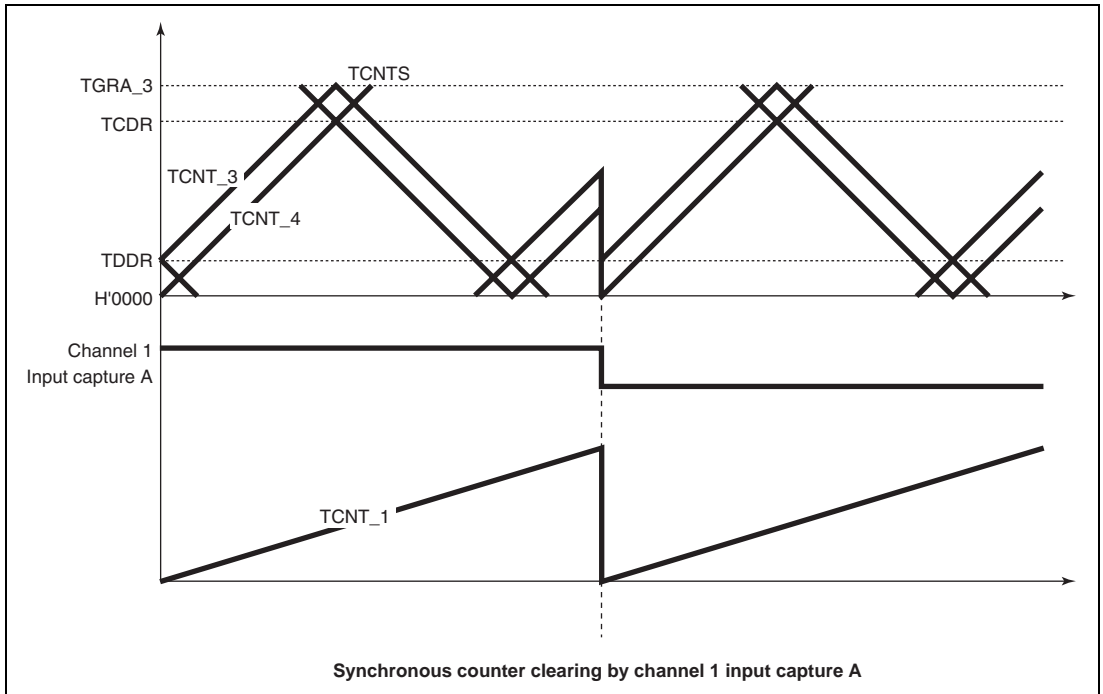
**Figure 9.54 Example of Toggle Output Waveform Synchronized with PWM Output**

### 13. Counter Clearing by Another Channel

In complementary PWM mode, by setting a mode for synchronization with another channel by means of the timer synchronous register (TSYR), and selecting synchronous clearing with bits CCLR2 to CCLR0 in the timer control register (TCR), it is possible to have TCNT\_3, TCNT\_4, and TCNTS cleared by another channel.

Figure 9.55 illustrates the operation.

Use of this function enables counter clearing and restarting to be performed by means of an external signal.



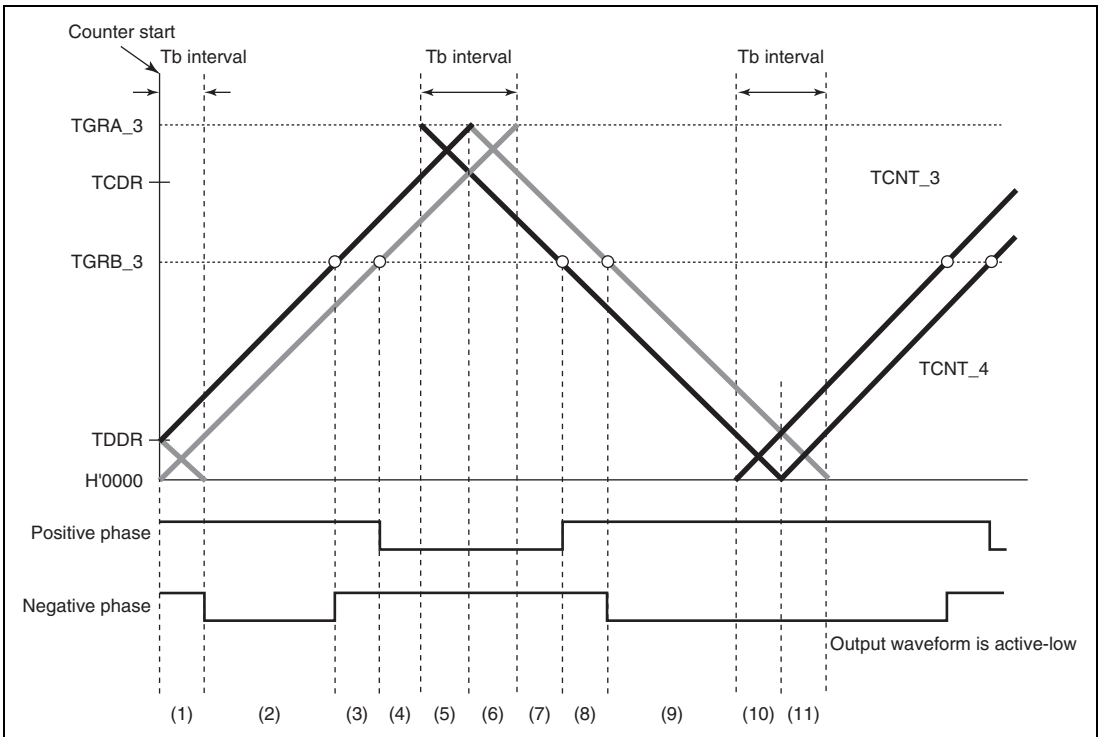
**Figure 9.55 Counter Clearing Synchronized with Another Channel**

#### 14. Output Waveform Control at Synchronous Counter Clearing in Complementary PWM Mode

Setting the WRE bit in TWCR to 1 suppresses initial output when synchronous counter clearing occurs in the  $T_b$  interval at the trough in complementary PWM mode and controls abrupt change in duty cycle at synchronous counter clearing.

Initial output suppression is applicable only when synchronous clearing occurs in the  $T_b$  interval at the trough as indicated by (10) or (11) in figure 9.56. When synchronous clearing occurs outside that interval, the initial value specified by the OLS bits in TOCR is output. Even in the  $T_b$  interval at the trough, if synchronous clearing occurs in the initial value output period (indicated by (1) in figure 9.56) immediately after the counters start operation, initial value output is not suppressed.

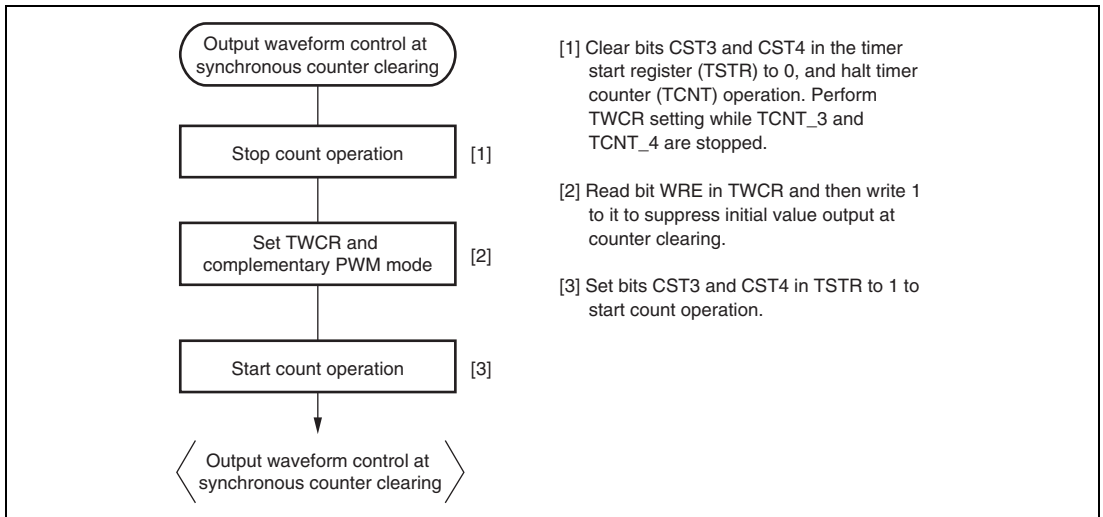
In the MTU2, synchronous clearing generated in channels 0 to 2 in the MTU2 can cause counter clearing.



**Figure 9.56 Timing for Synchronous Counter Clearing**

— Example of Procedure for Setting Output Waveform Control at Synchronous Counter Clearing in Complementary PWM Mode

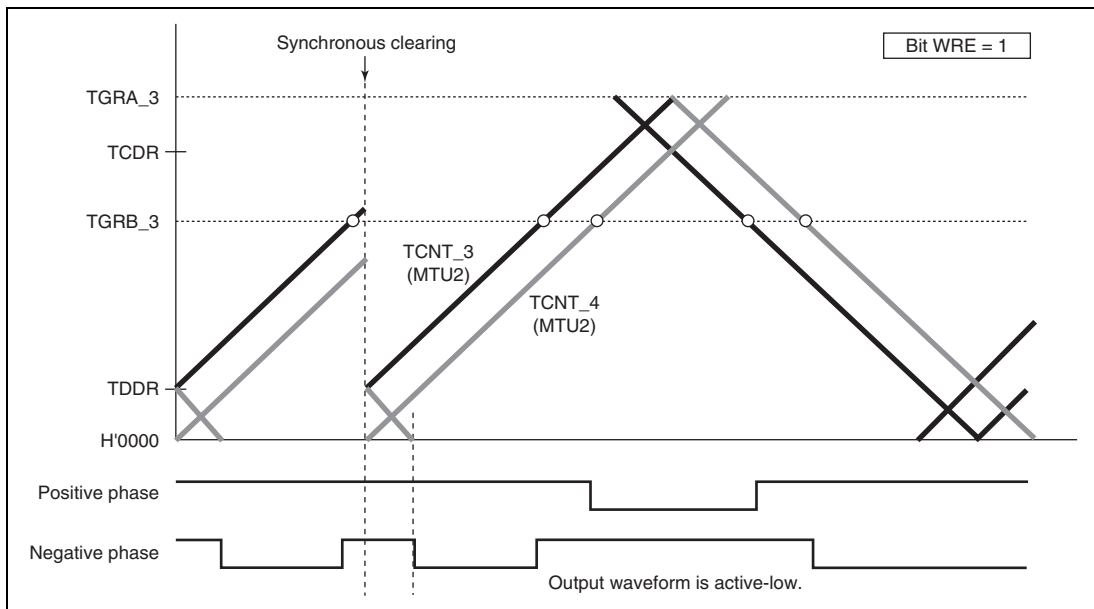
An example of the procedure for setting output waveform control at synchronous counter clearing in complementary PWM mode is shown in figure 9.57.



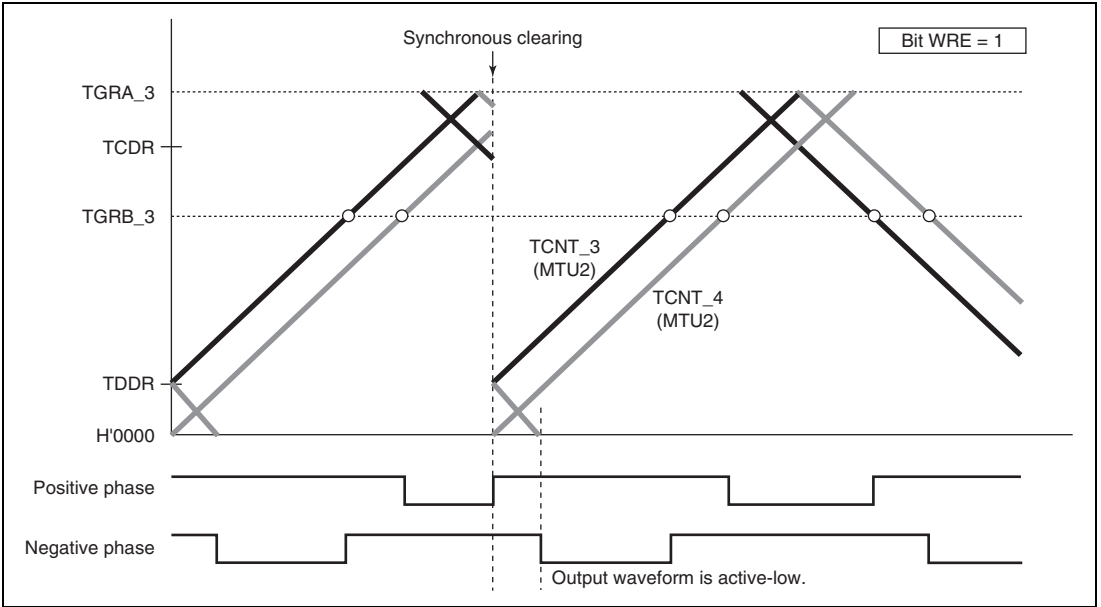
**Figure 9.57 Example of Procedure for Setting Output Waveform Control at Synchronous Counter Clearing in Complementary PWM Mode**

— Examples of Output Waveform Control at Synchronous Counter Clearing in Complementary PWM Mode

Figures 9.58 to 9.61 show examples of output waveform control in which the MTU2 operates in complementary PWM mode and synchronous counter clearing is generated while the WRE bit in TWCR is set to 1. In the examples shown in figures 9.58 to 9.61, synchronous counter clearing occurs at timing (3), (6), (8), and (11) shown in figure 9.56, respectively.

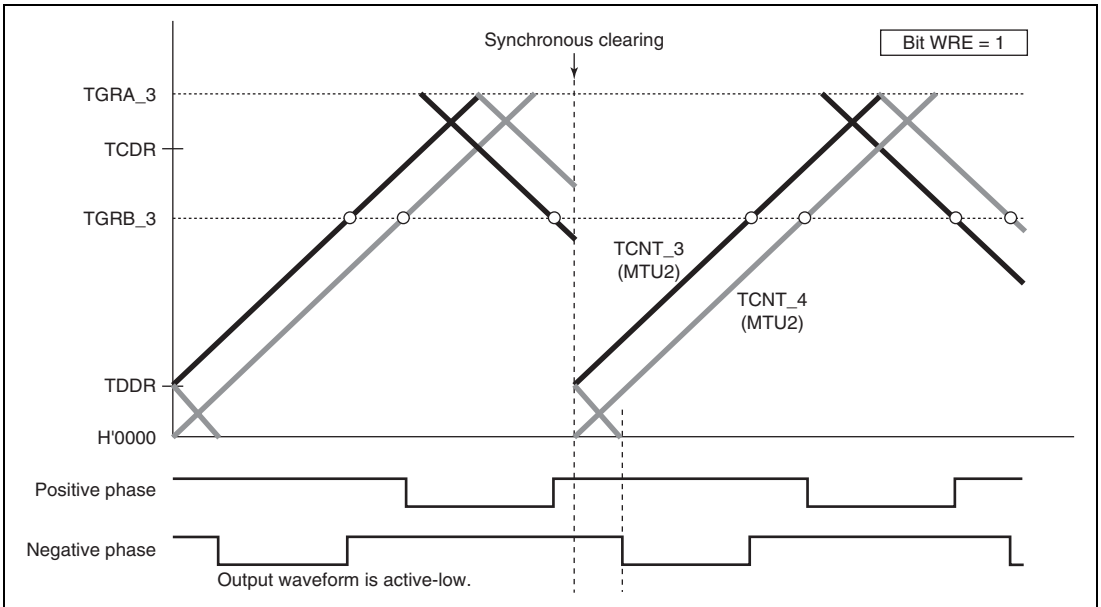


**Figure 9.58 Example of Synchronous Clearing in Dead Time during Up-Counting (Timing (3) in Figure 9.56; Bit WRE of TWCR in MTU2 is 1)**

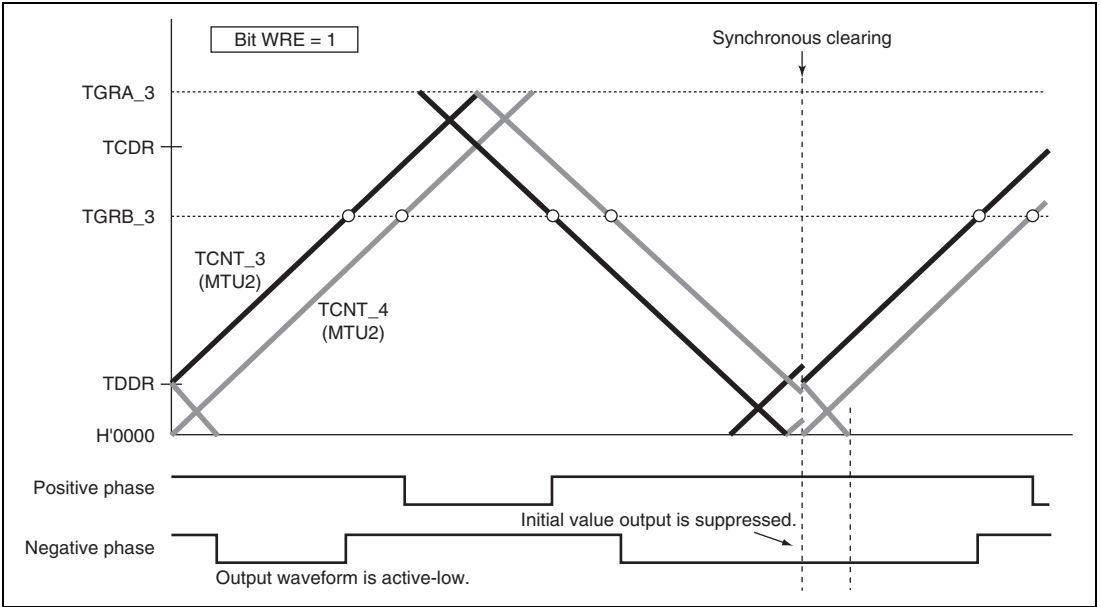


**Figure 9.59 Example of Synchronous Clearing in Interval Tb at Crest**  
 (Timing (6) in Figure 9.56; Bit WRE of TWCR in MTU2 is 1)





**Figure 9.60 Example of Synchronous Clearing in Dead Time during Down-Counting (Timing (8) in Figure 9.56; Bit WRE of TWCR is 1)**



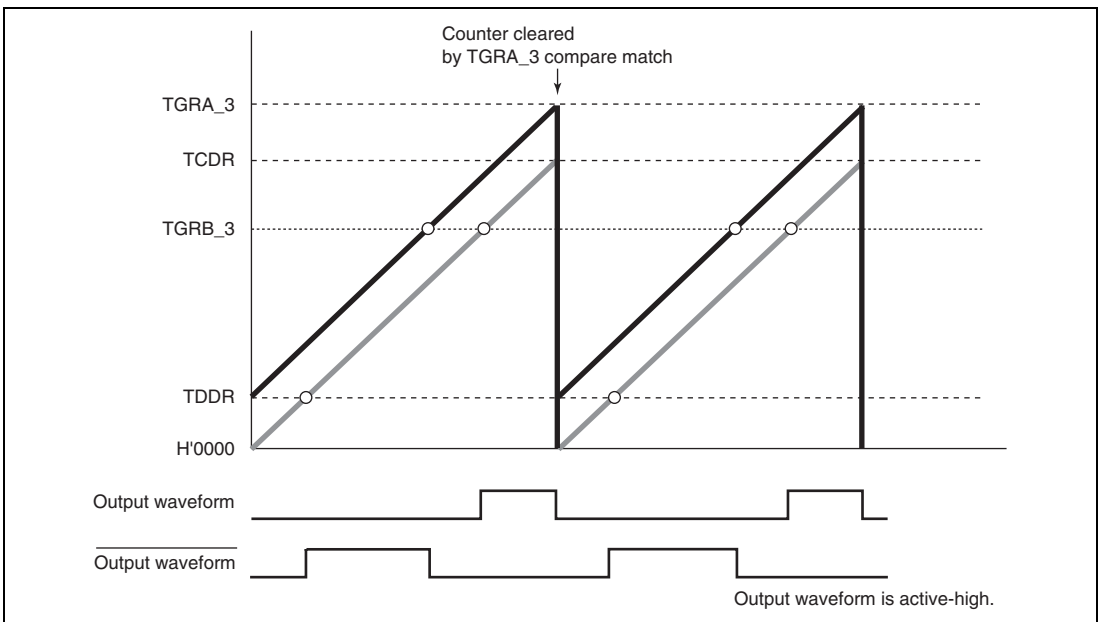
**Figure 9.61 Example of Synchronous Clearing in Interval Tb at Trough  
(Timing (11) in Figure 9.56; Bit WRE of TWCR is 1)**

### 15. Counter Clearing by TGRA\_3 Compare Match

In complementary PWM mode, by setting the CCE bit in the timer waveform control register (TWCR), it is possible to have TCNT\_3, TCNT\_4, and TCNTS cleared by TGRA\_3 compare match.

Figure 9.62 illustrates an operation example.

- Notes:
1. Use this function only in complementary PWM mode 1 (transfer at crest)
  2. Do not specify synchronous clearing by another channel (do not set the SYNC0 to SYNC4 bits in the timer synchronous register (TSYR) to 1 or the CE0A, CE0B, CE0C, CE0D, CE1A, CE1B, CE1C, and CE1D bits in the timer synchronous clear register (TSYCR) to 1).
  3. Do not set the PWM duty value to H'0000.
  4. Do not set the PSYE bit in timer output control register 1 (TOCR1) to 1.



**Figure 9.62 Example of Counter Clearing Operation by TGRA\_3 Compare Match**

## 16. Example of AC Synchronous Motor (Brushless DC Motor) Drive Waveform Output

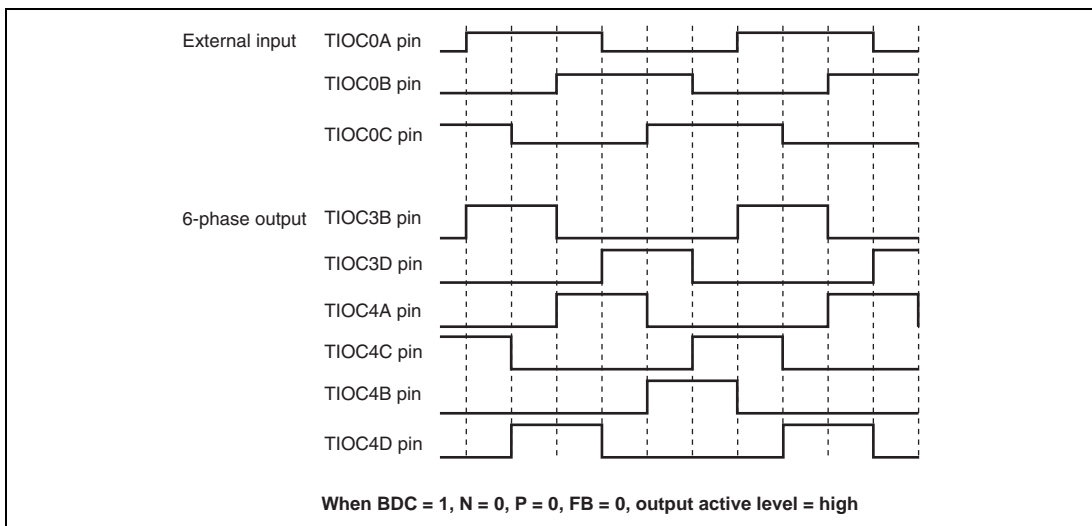
In complementary PWM mode, a brushless DC motor can easily be controlled using the timer gate control register (TGCR). Figures 9.63 to 9.66 show examples of brushless DC motor drive waveforms created using TGCR.

When output phase switching for a 3-phase brushless DC motor is performed by means of external signals detected with a Hall element, etc., clear the FB bit in TGCR to 0. In this case, the external signals indicating the polarity position are input to channel 0 timer input pins TIOC0A, TIOC0B, and TIOC0C (set with PFC). When an edge is detected at pin TIOC0A, TIOC0B, or TIOC0C, the output on/off state is switched automatically.

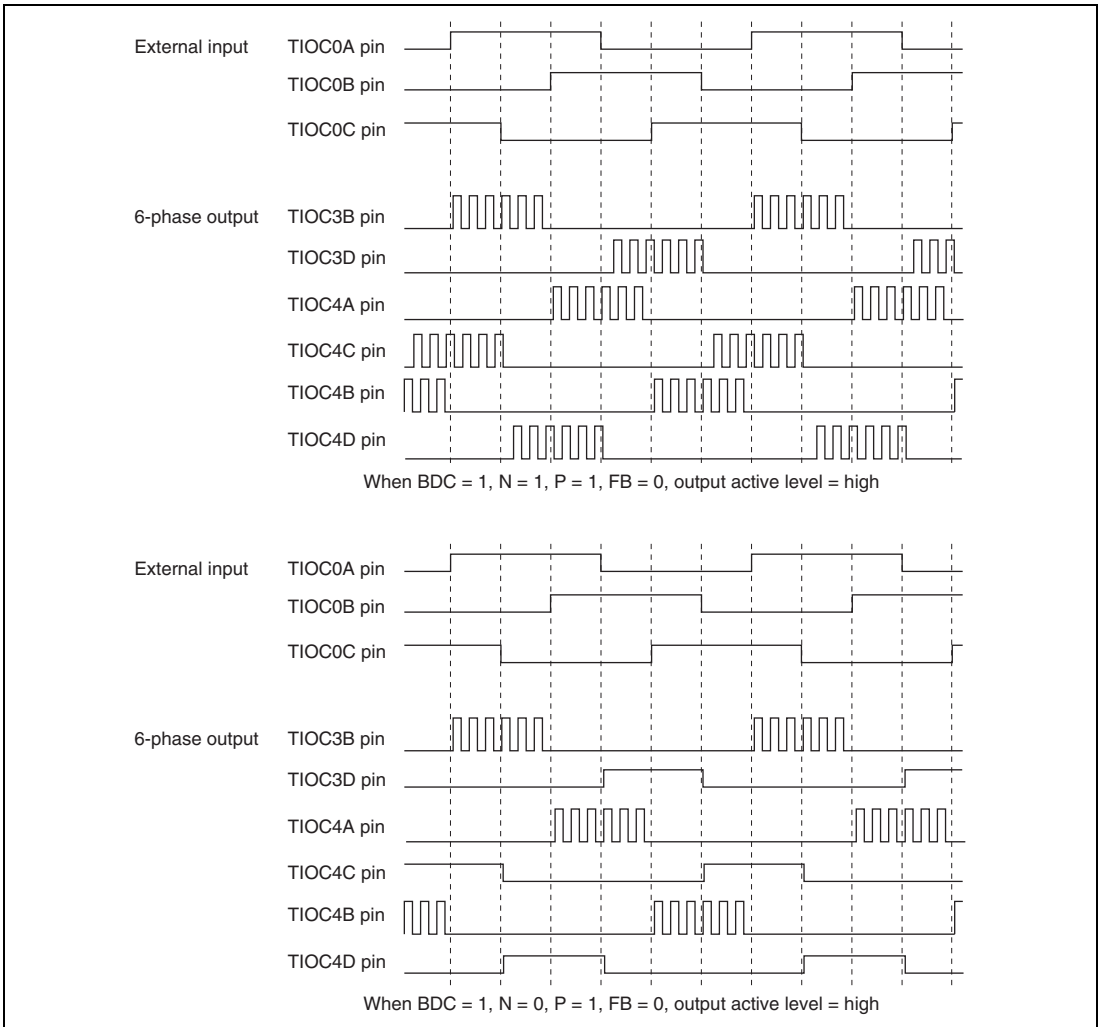
When the FB bit is 1, the output on/off state is switched when the UF, VF, or WF bit in TGCR is cleared to 0 or set to 1.

The drive waveforms are output from the complementary PWM mode 6-phase output pins. With this 6-phase output, in the case of on output, it is possible to use complementary PWM mode output and perform chopping output by setting the N bit or P bit to 1. When the N bit or P bit is 0, level output is selected.

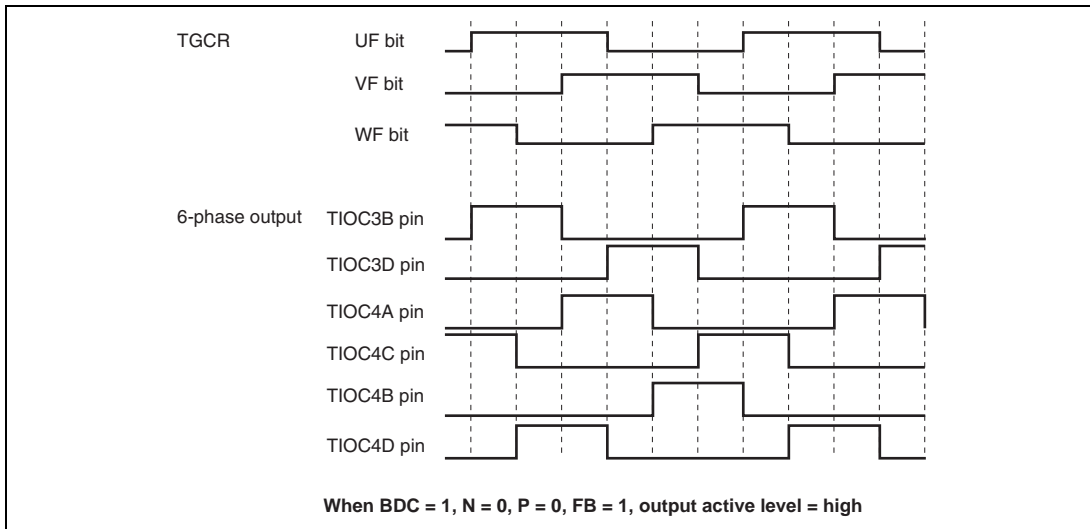
The 6-phase output active level (on output level) can be set with the OLSN and OLSP bits in the timer output control register (TOCR) regardless of the setting of the N and P bits.



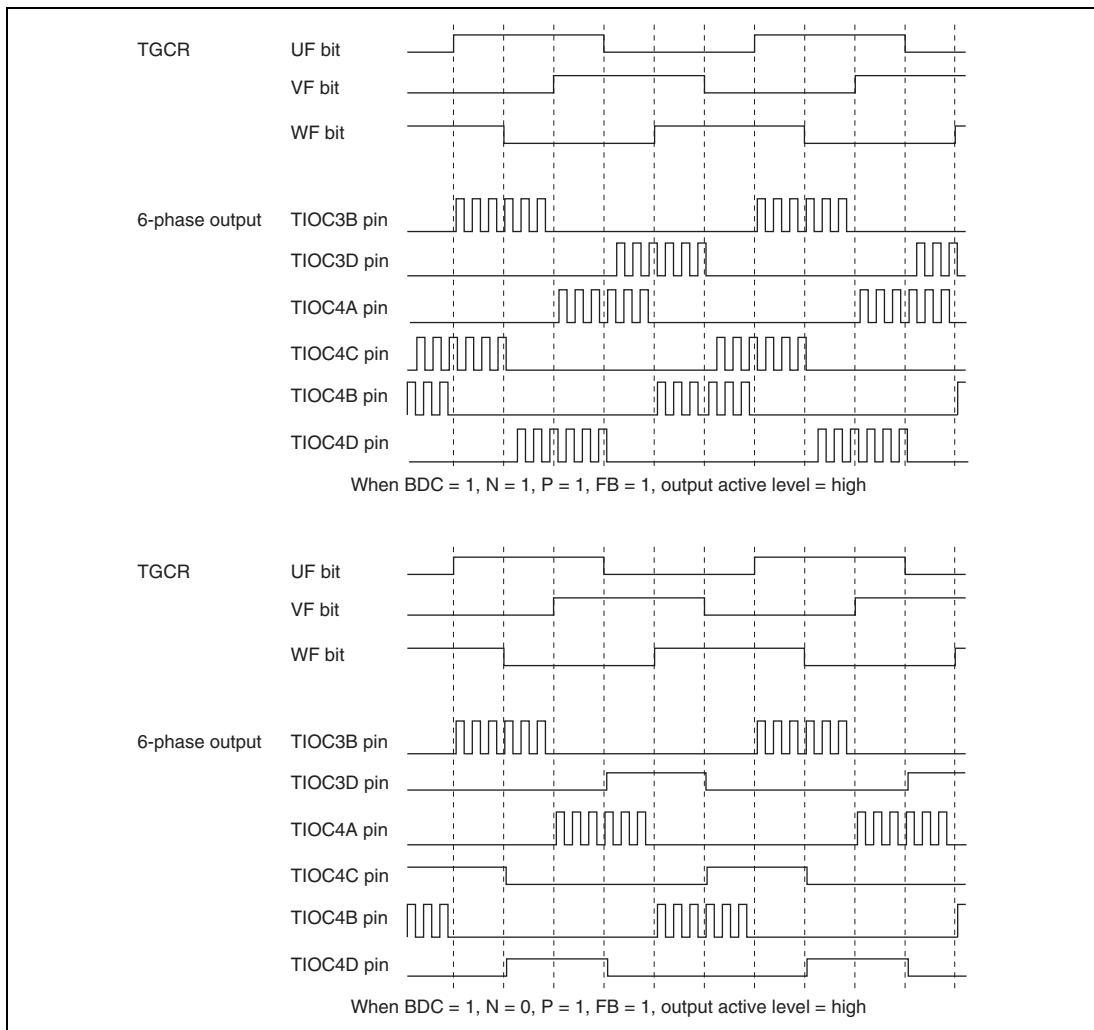
**Figure 9.63 Example of Output Phase Switching by External Input (1)**



**Figure 9.64 Example of Output Phase Switching by External Input (2)**



**Figure 9.65 Example of Output Phase Switching by Means of UF, VF, WF Bit Settings (1)**



**Figure 9.66 Example of Output Phase Switching by Means of UF, VF, WF Bit Settings (2)**

## 17. A/D Converter Start Request Setting

In complementary PWM mode, an A/D converter start request can be issued using a TGRA\_3 compare-match, TCNT\_4 underflow (trough), or compare-match on a channel other than channels 3 and 4.

When start requests using a TGRA\_3 compare-match are specified, A/D conversion can be started at the crest of the TCNT\_3 count.

A/D converter start requests can be set by setting the TTGE bit to 1 in the timer interrupt enable register (TIER). To issue an A/D converter start request at a TCNT\_4 underflow (trough), set the TTGE2 bit in TIER\_4 to 1.

### **Interrupt Skipping in Complementary PWM Mode:**

Interrupts TGIA\_3 (at the crest) and TCIV\_4 (at the trough) in channels 3 and 4 can be skipped up to seven times by making settings in the timer interrupt skipping set register (TITCR).

Transfers from a buffer register to a temporary register or a compare register can be skipped in coordination with interrupt skipping by making settings in the timer buffer transfer register (TBTER). For the linkage with buffer registers, refer to description 3, Buffer Transfer Control Linked with Interrupt Skipping, below.

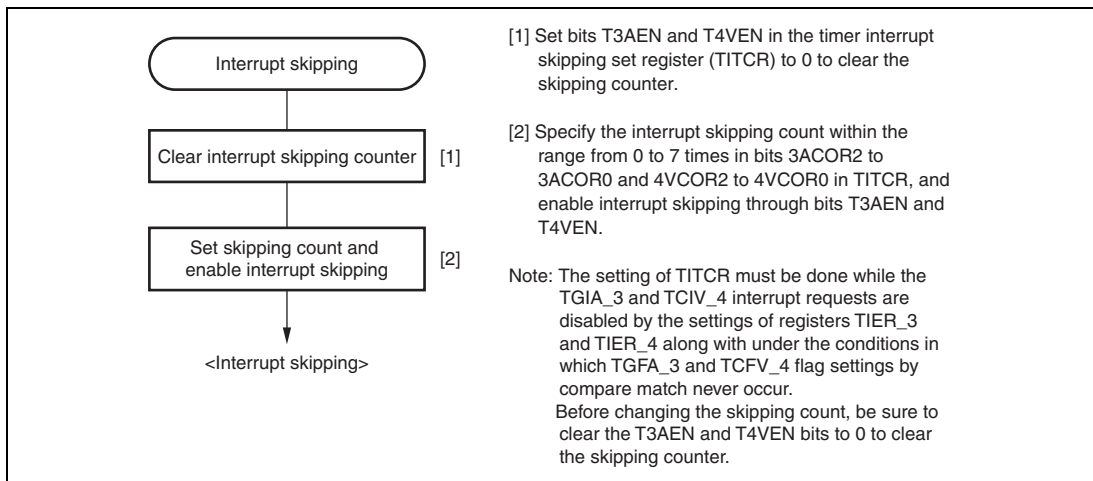
A/D converter start requests generated by the A/D converter start request delaying function can also be skipped in coordination with interrupt skipping by making settings in the timer A/D converter request control register (TADCR). For the linkage with the A/D converter start request delaying function, refer to section 9.4.9, A/D Converter Start Request Delaying Function.

The setting of the timer interrupt skipping setting register (TITCR) must be done while the TGIA\_3 and TCIV\_4 interrupt requests are disabled by the settings of registers TIER\_3 and TIER\_4 along with under the conditions in which TGFA\_3 and TCFV\_4 flag settings by compare match never occur. Before changing the skipping count, be sure to clear the T3AEN and T4VEN bits to 0 to clear the skipping counter.

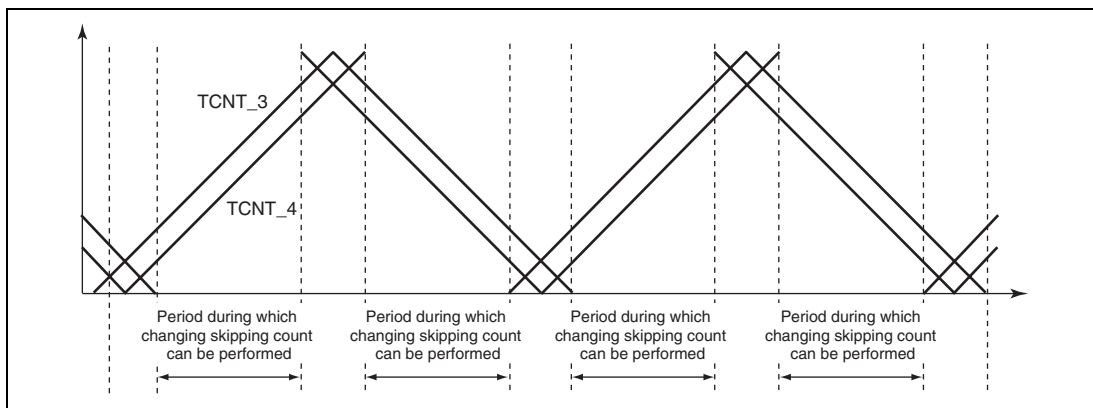
#### 1. Example of Interrupt Skipping Operation Setting Procedure

Figure 9.67 shows an example of the interrupt skipping operation setting procedure. Figure 9.68 shows the periods during which interrupt skipping count can be changed.





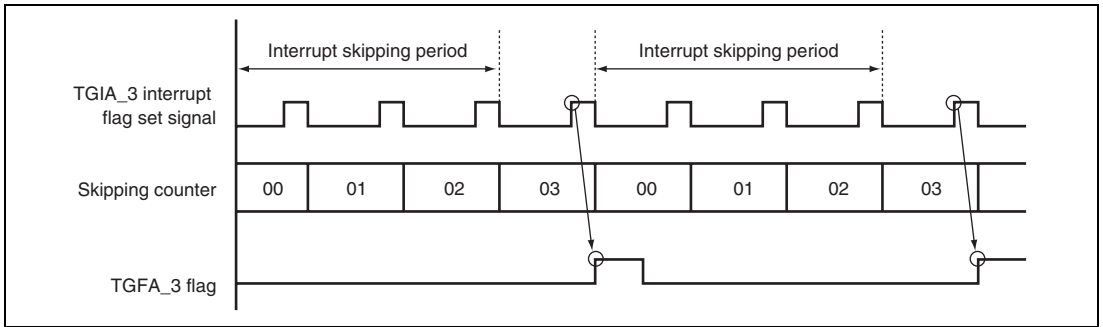
**Figure 9.67 Example of Interrupt Skipping Operation Setting Procedure**



**Figure 9.68 Periods during which Interrupt Skipping Count can be Changed**

## 2. Example of Interrupt Skipping Operation

Figure 9.69 shows an example of TGIA\_3 interrupt skipping in which the interrupt skipping count is set to three by the 3ACOR bit and the T3AEN bit is set to 1 in the timer interrupt skipping set register (TITCR).



**Figure 9.69 Example of Interrupt Skipping Operation**

### 3. Buffer Transfer Control Linked with Interrupt Skipping

In complementary PWM mode, whether to transfer data from a buffer register to a temporary register and whether to link the transfer with interrupt skipping can be specified with the BTE1 and BTE0 bits in the timer buffer transfer set register (TBTER).

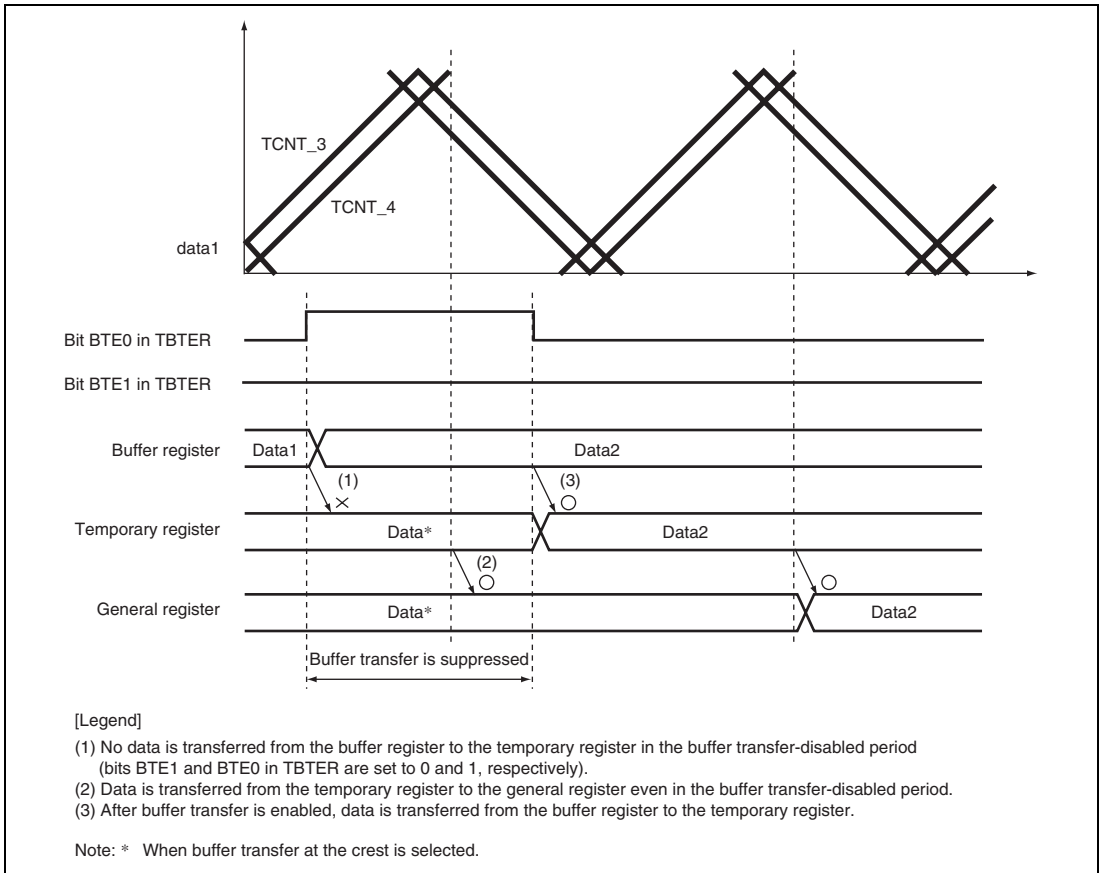
Figure 9.70 shows an example of operation when buffer transfer is suppressed (BTE1 = 0 and BTE0 = 1). While this setting is valid, data is not transferred from the buffer register to the temporary register.

Figure 9.71 shows an example of operation when buffer transfer is linked with interrupt skipping (BTE1 = 1 and BTE0 = 0). While this setting is valid, data is not transferred from the buffer register outside the buffer transfer-enabled period.

The data transfer timing is two types. That is, from the buffer register to the temporary register and from the temporary register to the buffer register. These timings depend on a programming timing to the buffer register after an interrupt is generated.

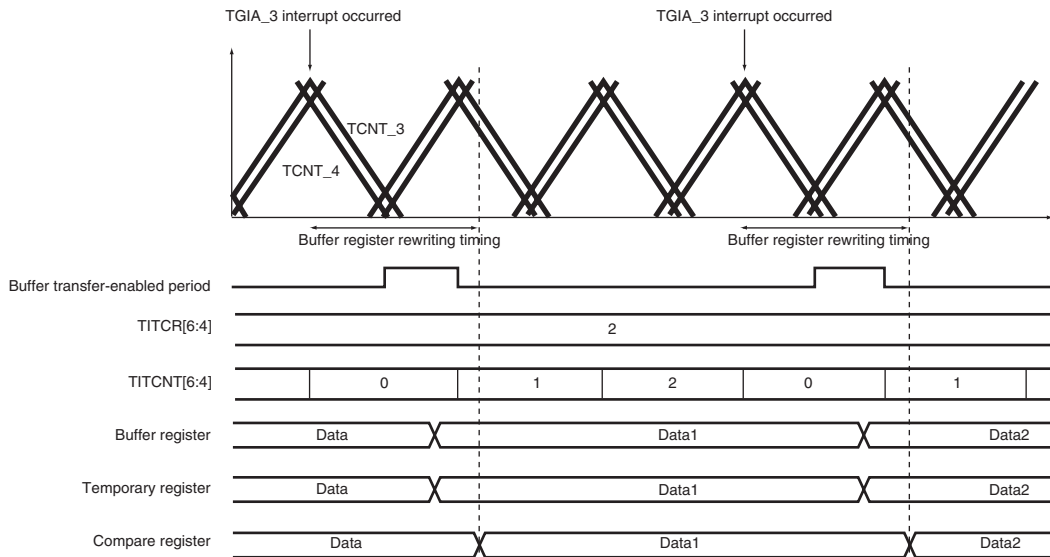
Note that the buffer transfer-enabled period depends on the T3AEN and T4VEN bit settings in the timer interrupt skipping set register (TITCR). Figure 9.72 shows the relationship between the T3AEN and T4VEN bit settings in TITCR and buffer transfer-enabled period.

**Note:** This function must always be used in combination with interrupt skipping. When interrupt skipping is disabled (the T3AEN and T4VEN bits in the timer interrupt skipping set register (TITCR) are cleared to 0 or the skipping count set bits (3ACOR and 4VCOR) in TITCR are cleared to 0), make sure that buffer transfer is not linked with interrupt skipping (clear the BTE1 bit in the timer buffer transfer set register (TBTER) to 0). If buffer transfer is linked with interrupt skipping while interrupt skipping is disabled, buffer transfer is never performed.

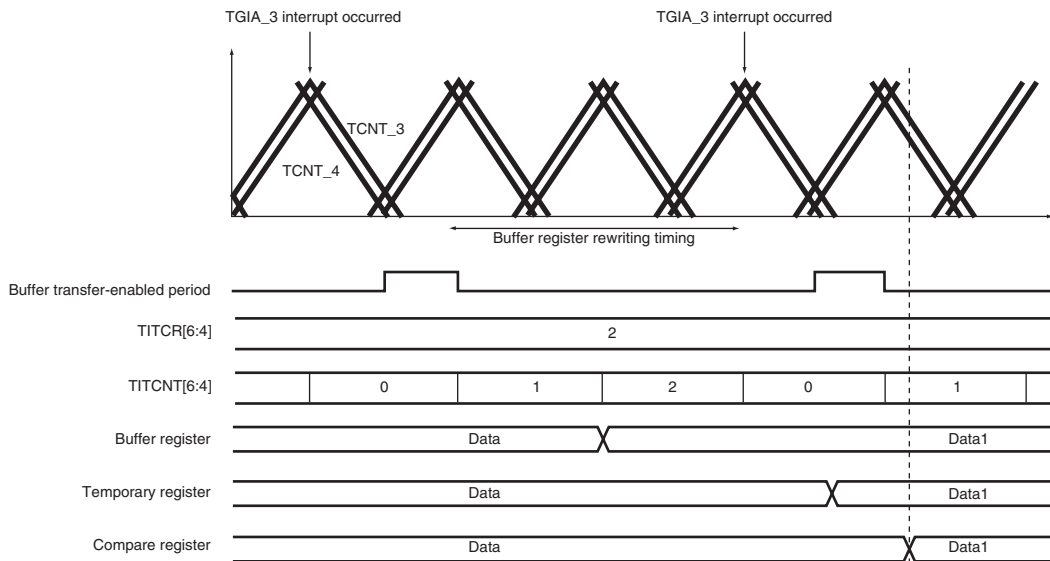


**Figure 9.70 Example of Operation when Buffer Transfer is Suppressed (BTE1 = 0 and BTE0 = 1)**

(1) When rewriting a buffer register within a carrier cycle after TGIA\_3 interrupt occurred.

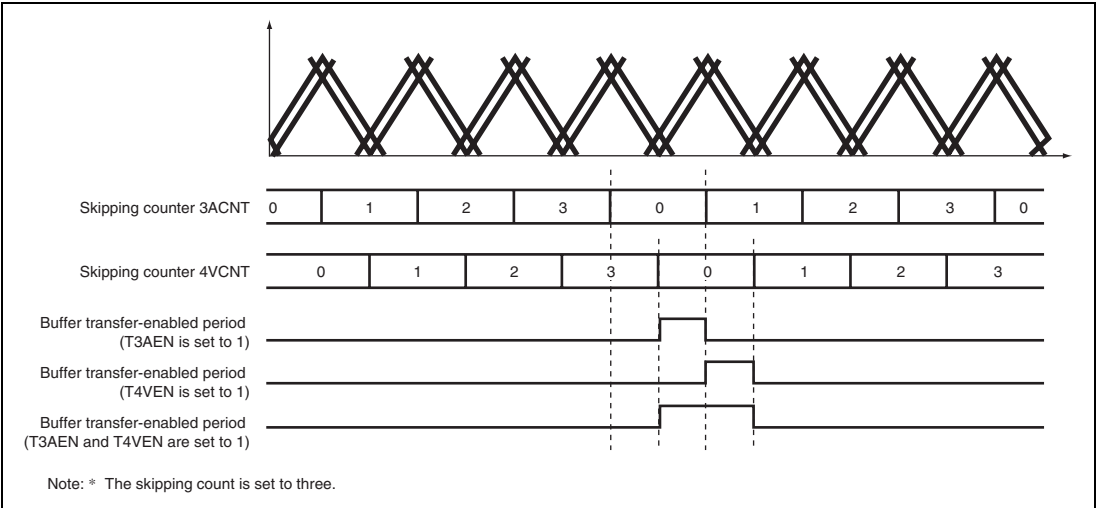


(2) When rewriting a buffer register after a carrier cycle passed from occurring TGIA\_3 interrupt.



Note: \* Buffer transfer at the crest is selected.  
 The skipping count is set to two.  
 T3AEN is set to 1.

**Figure 9.71 Example of Operation when Buffer Transfer is Linked with Interrupt Skipping (BTE1 = 1 and BTE0 = 0)**



**Figure 9.72 Relationship between Bits T3AEN and T4VEN in TITCR and Buffer Transfer-Enabled Period**

## Complementary PWM Mode Output Protection Function:

Complementary PWM mode output has the following protection functions.

### 1. Register and counter miswrite prevention function

With the exception of the buffer registers, which can be rewritten at any time, access by the CPU can be enabled or disabled for the mode registers, control registers, compare registers, and counters used in complementary PWM mode by means of the RWE bit in the timer read/write enable register (TRWER). The applicable registers are some (21 in total) of the registers in channels 3 and 4 shown in the following:

— TCR\_3 and TCR\_4, TMDR\_3 and TMDR\_4, TIORH\_3 and TIORH\_4, TIORL\_3 and TIORL\_4, TIER\_3 and TIER\_4, TCNT\_3 and TCNT\_4, TGRA\_3 and TGRA\_4, TGRB\_3 and TGRB\_4, TOER, TOCR, TGCR, TCDR, and TDDR.

This function enables miswriting due to CPU runaway to be prevented by disabling CPU access to the mode registers, control registers, and counters. When the applicable registers are read in the access-disabled state, undefined values are returned. Writing to these registers is ignored.

### 2. Halting of PWM output by external signal

The 6-phase PWM output pins can be set automatically to the high-impedance state by inputting specified external signals. There are four external signal input pins.

See section 10, Port Output Enable (POE), for details.

### 3. Halting of PWM output when oscillator is stopped

If it is detected that the clock input to this LSI has stopped, the 6-phase PWM output pins automatically go to the high-impedance state. The pin states are not guaranteed when the clock is restarted.

See section 4.7, Function for Detecting Oscillator Stop.

### 9.4.9 A/D Converter Start Request Delaying Function

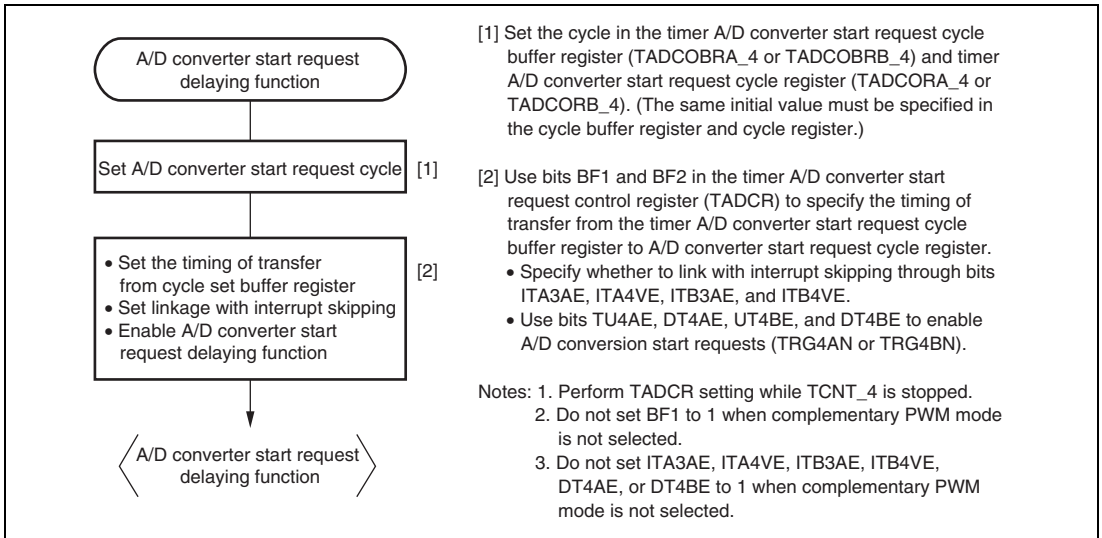
A/D converter start requests can be issued in channel 4 by making settings in the timer A/D converter start request control register (TADCR), timer A/D converter start request cycle set registers (TADCORA\_4 and TADCORB\_4), and timer A/D converter start request cycle set buffer registers (TADCOBRA\_4 and TADCOBRB\_4).

The A/D converter start request delaying function compares TCNT\_4 with TADCORA\_4 or TADCORB\_4, and when their values match, the function issues a respective A/D converter start request (TRG4AN or TRG4BN).

A/D converter start requests (TRG4AN and TRG4BN) can be skipped in coordination with interrupt skipping by making settings in the ITA3AE, ITA4VE, ITB3AE, and ITB4VE bits in TADCR.

#### 1. Example of Procedure for Specifying A/D Converter Start Request Delaying Function

Figure 9.73 shows an example of procedure for specifying the A/D converter start request delaying function.

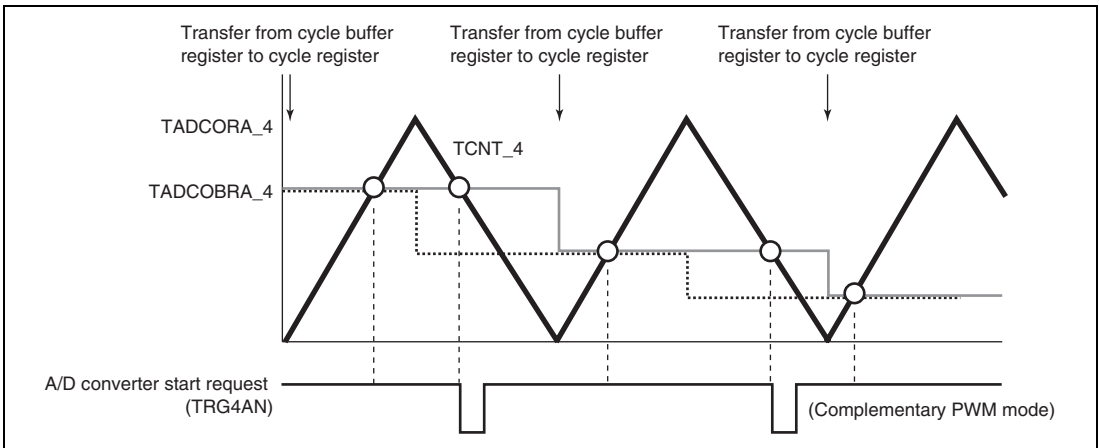


**Figure 9.73 Example of Procedure for Specifying A/D Converter Start Request Delaying Function**



## 2. Basic Operation Example of A/D Converter Start Request Delaying Function

Figure 9.74 shows a basic example of A/D converter request signal (TRG4AN) operation when the trough of TCNT\_4 is specified for the buffer transfer timing and an A/D converter start request signal is output during TCNT\_4 down-counting.



**Figure 9.74 Basic Example of A/D Converter Start Request Signal (TRG4AN) Operation**

## 3. Buffer Transfer

The data in the timer A/D converter start request cycle set registers (TADCORA\_4 and TADCOBRB\_4) is updated by writing data to the timer A/D converter start request cycle set buffer registers (TADCOBRA\_4 and TADCOBRB\_4). Data is transferred from the buffer registers to the respective cycle set registers at the timing selected with the BF1 and BF0 bits in the timer A/D converter start request control register (TADCR\_4).

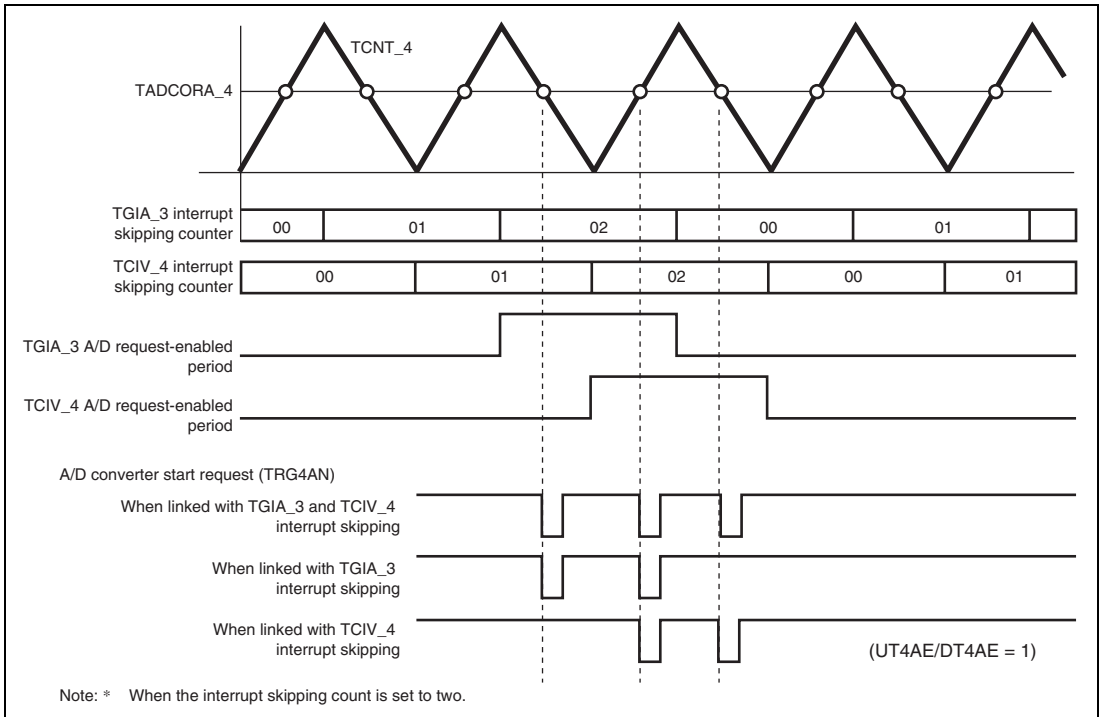
## 4. A/D Converter Start Request Delaying Function Linked with Interrupt Skipping

A/D converter start requests (TRG4AN and TRG4BN) can be issued in coordination with interrupt skipping by making settings in the ITA3AE, ITA4VE, ITB3AE, and ITB4VE bits in the timer A/D converter start request control register (TADCR).

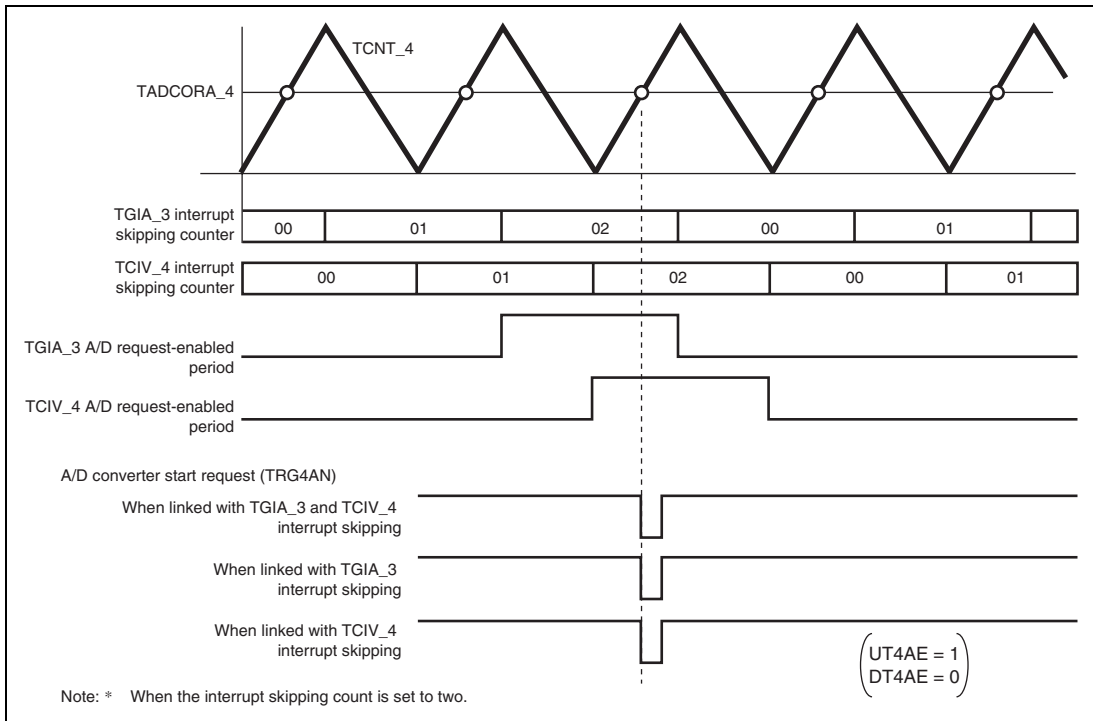
Figure 9.75 shows an example of A/D converter start request signal (TRG4AN) operation when TRG4AN output is enabled during TCNT\_4 up-counting and down-counting and A/D converter start requests are linked with interrupt skipping.

Figure 9.76 shows another example of A/D converter start request signal (TRG4AN) operation when TRG4AN output is enabled during TCNT\_4 up-counting and A/D converter start requests are linked with interrupt skipping.

Note: This function must be used in combination with interrupt skipping.  
 When interrupt skipping is disabled (the T3AEN and T4VEN bits in the timer interrupt skipping set register (TITCR) are cleared to 0 or the skipping count set bits (3ACOR and 4VCOR) in TITCR are cleared to 0), make sure that A/D converter start requests are not linked with interrupt skipping (clear the ITA3AE, ITA4VE, ITB3AE, and ITB4VE bits in the timer A/D converter start request control register (TADCR) to 0).



**Figure 9.75 Example of A/D Converter Start Request Signal (TRG4AN) Operation Linked with Interrupt Skipping**



**Figure 9.76 Example of A/D Converter Start Request Signal (TRG4AN) Operation Linked with Interrupt Skipping**

### 9.4.10 External Pulse Width Measurement

The pulse widths of up to three external input lines can be measured in channel 5.

#### Example of External Pulse Width Measurement Setting Procedure:

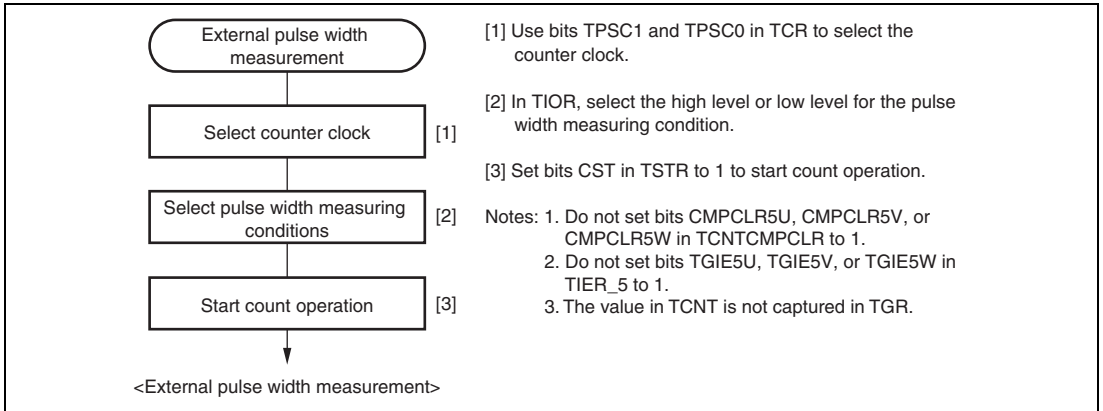


Figure 9.77 Example of External Pulse Width Measurement Setting Procedure

#### Example of External Pulse Width Measurement:

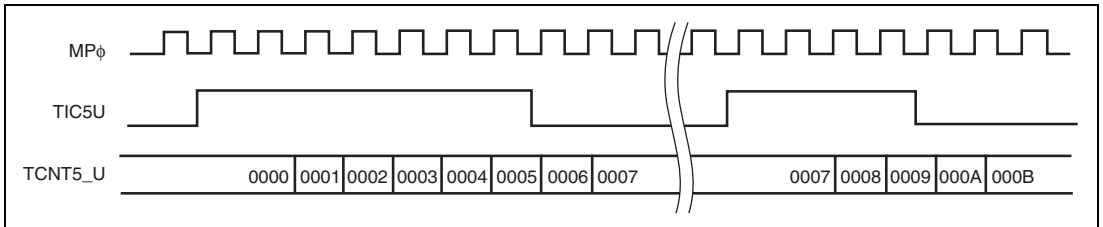
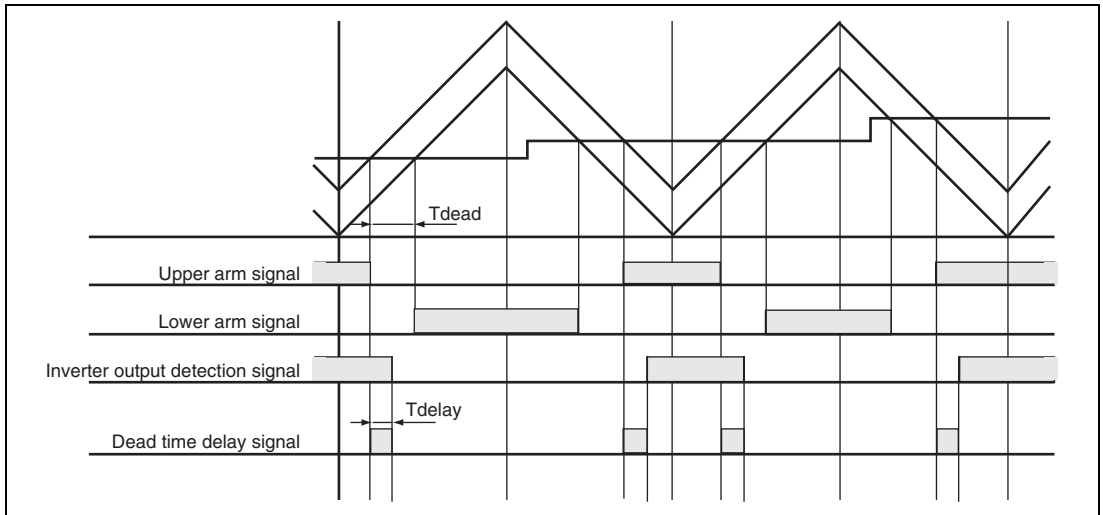


Figure 9.78 Example of External Pulse Width Measurement (Measuring High Pulse Width)

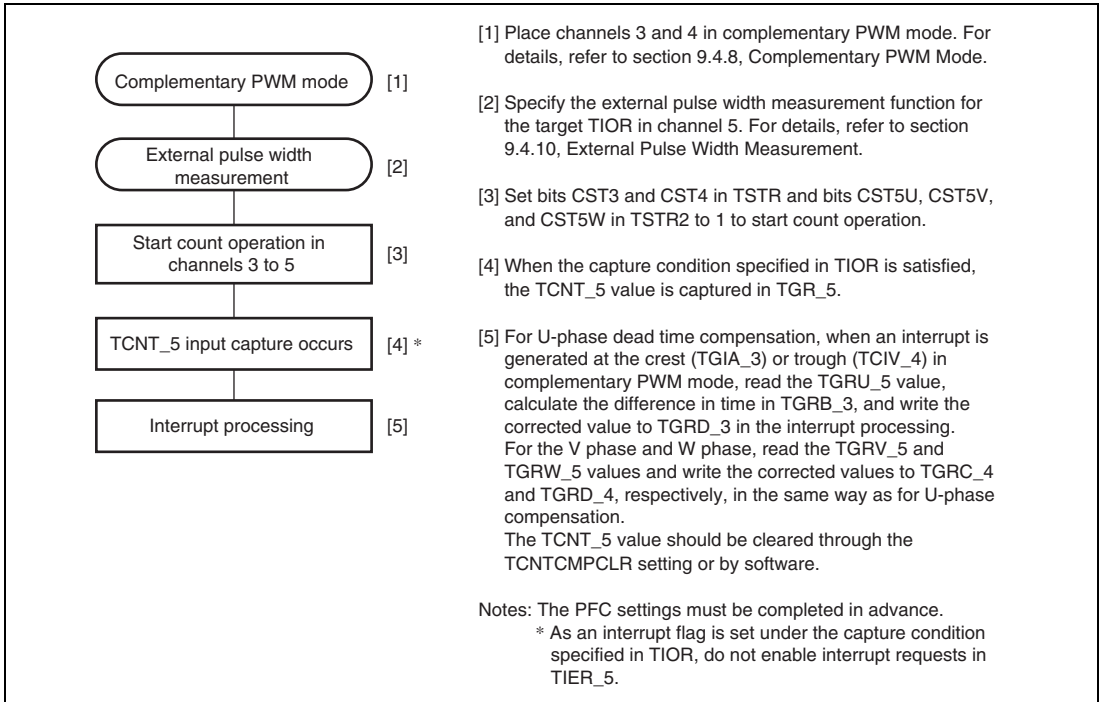
### 9.4.11 Dead Time Compensation

By measuring the delay of the output waveform and reflecting it to duty, the external pulse width measurement function can be used as the dead time compensation function while the complementary PWM is in operation.

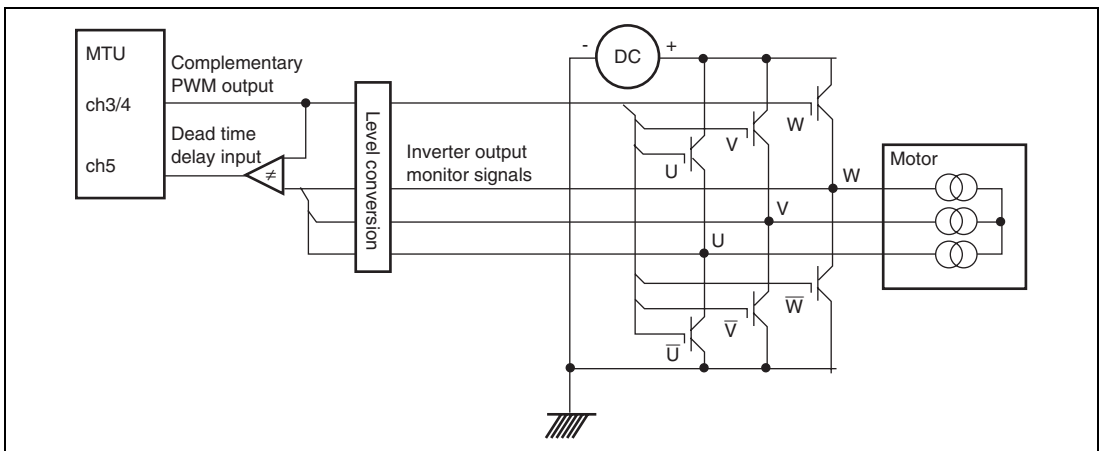


**Figure 9.79 Delay in Dead Time in Complementary PWM Operation**

**Example of Dead Time Compensation Setting Procedure:** Figure 9.80 shows an example of dead time compensation setting procedure by using three counters in channel 5.



**Figure 9.80 Example of Dead Time Compensation Setting Procedure**

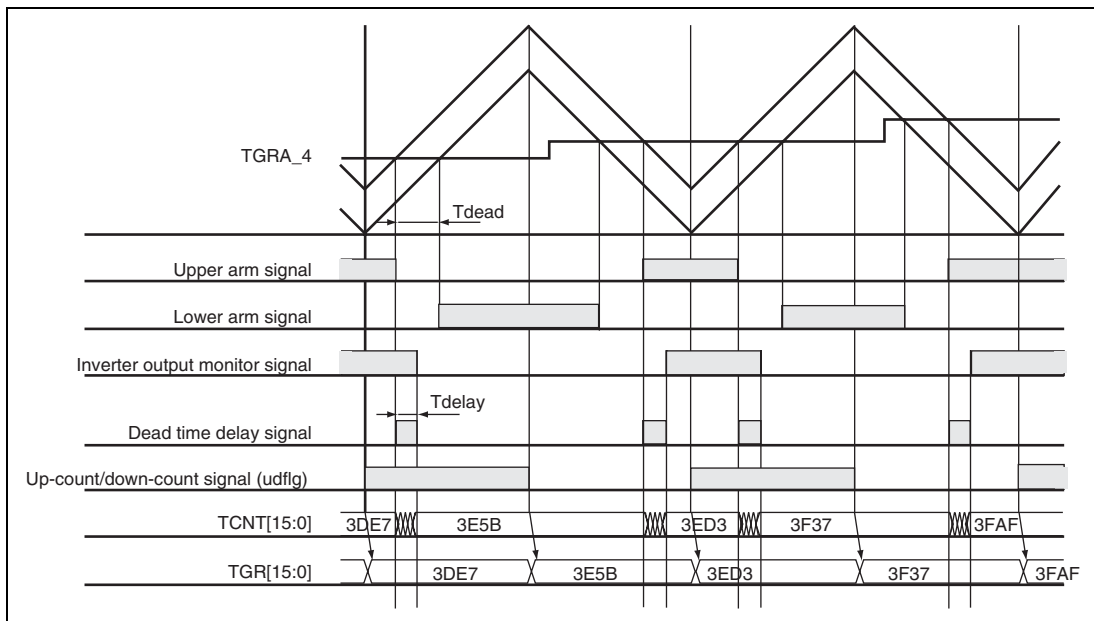


**Figure 9.81 Example of Motor Control Circuit Configuration**

### 9.4.12 TCNT Capture at Crest and/or Trough in Complementary PWM Operation

The TCNT value is captured in TGR at either the crest or trough or at both the crest and trough during complementary PWM operation. The timing for capturing in TGR can be selected by TIOR.

Figure 9.82 is an operating example in which TCNT is used as a free-running counter without being cleared, and the TCNT value is captured in TGR at the specified timing (either crest or trough, or both crest and trough).



**Figure 9.82 TCNT Capturing at Crest and/or Trough in Complementary PWM Operation**

## 9.5 Interrupt Sources

### 9.5.1 Interrupt Sources and Priorities

There are three kinds of MTU2 interrupt source; TGR input capture/compare match, TCNT overflow, and TCNT underflow. Each interrupt source has its own status flag and enable/disabled bit, allowing the generation of interrupt request signals to be enabled or disabled individually.

When an interrupt request is generated, the corresponding status flag in TSR is set to 1. If the corresponding enable/disable bit in TIER is set to 1 at this time, an interrupt is requested. The interrupt request is cleared by clearing the status flag to 0.

Relative channel priorities can be changed by the interrupt controller, however the priority order within a channel is fixed. For details, see section 6, Interrupt Controller (INTC).

Table 9.57 lists the MTU2 interrupt sources.





**Input Capture/Compare Match Interrupt:** An interrupt is requested if the TGIE bit in TIER is set to 1 when the TGF flag in TSR is set to 1 by the occurrence of a TGR input capture/compare match on a particular channel. The interrupt request is cleared by clearing the TGF flag to 0. The MTU2 has 21 input capture/compare match interrupts, six for channel 0, four each for channels 3 and 4, two each for channels 1 and 2, and three for channel 5. The TGFE\_0 and TGFF\_0 flags in channel 0 are not set by the occurrence of an input capture.

**Overflow Interrupt:** An interrupt is requested if the TCIEV bit in TIER is set to 1 when the TCFV flag in TSR is set to 1 by the occurrence of TCNT overflow on a channel. The interrupt request is cleared by clearing the TCFV flag to 0. The MTU2 has five overflow interrupts, one for each channel.

**Underflow Interrupt:** An interrupt is requested if the TCIEU bit in TIER is set to 1 when the TCFU flag in TSR is set to 1 by the occurrence of TCNT underflow on a channel. The interrupt request is cleared by clearing the TCFU flag to 0. The MTU2 has two underflow interrupts, one each for channels 1 and 2.

## 9.5.2 A/D Converter Activation

The A/D converter can be activated by one of the following three methods in the MTU2. Table 9.58 shows the relationship between interrupt sources and A/D converter start request signals.

**A/D Converter Activation by TGRA Input Capture/Compare Match or at TCNT\_4 Trough in Complementary PWM Mode:** The A/D converter can be activated by the occurrence of a TGRA input capture/compare match in each channel. In addition, if complementary PWM operation is performed while the TTGE2 bit in TIER\_4 is set to 1, the A/D converter can be activated at the trough of TCNT\_4 count (TCNT\_4 = H'0000).

A/D converter start request signal TRGAN is issued to the A/D converter under either one of the following conditions.

- When the TGFA flag in TSR is set to 1 by the occurrence of a TGRA input capture/compare match on a particular channel while the TTGE bit in TIER is set to 1
- When the TCNT\_4 count reaches the trough (TCNT\_4 = H'0000) during complementary PWM operation while the TTGE2 bit in TIER\_4 is set to 1

When either condition is satisfied, if A/D converter start signal TRGAN from the MTU2 is selected as the trigger in the A/D converter, A/D conversion will start.

**A/D Converter Activation by Compare Match between TCNT\_0 and TGRE\_0:** The A/D converter can be activated by generating A/D converter start request signal TRG0N when a compare match occurs between TCNT\_0 and TGRE\_0 in channel 0.

When the TGFE flag in TSR2\_0 is set to 1 by the occurrence of a compare match between TCNT\_0 and TGRE\_0 in channel 0 while the TTGE2 bit in TIER2\_0 is set to 1, A/D converter start request TGR0N is issued to the A/D converter. If A/D converter start signal TGR0N from the MTU2 is selected as the trigger in the A/D converter, A/D conversion will start.

**A/D Converter Activation by A/D Converter Start Request Delaying Function:** The A/D converter can be activated by generating A/D converter start request signal TRG4AN or TRG4BN when the TCNT\_4 count matches the TADCORA or TADCORB value if the UT4AE, DT4AE, UT4BE, or DT4BE bit in the A/D converter start request control register (TADCR) is set to 1. For details, refer to section 9.4.9, A/D Converter Start Request Delaying Function.

A/D conversion will start if A/D converter start signal TRG4AN from the MTU2 is selected as the trigger in the A/D converter when TRG4AN is generated or if TRG4BN from the MTU2 is selected as the trigger in the A/D converter when TRG4BN is generated.

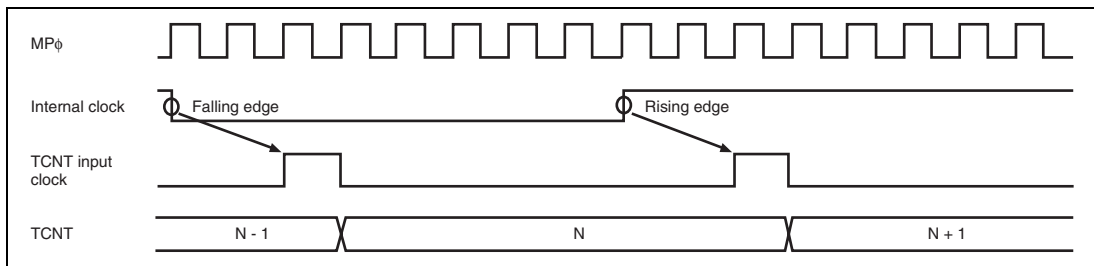
**Table 9.58 Interrupt Sources and A/D Converter Start Request Signals**

<b>Target Registers</b>	<b>Interrupt Source</b>	<b>A/D Converter Start Request Signal</b>
TGRA_0 and TCNT_0	Input capture/compare match	TRGAN
TGRA_1 and TCNT_1		
TGRA_2 and TCNT_2		
TGRA_3 and TCNT_3		
TGRA_4 and TCNT_4		
TCNT_4	TCNT_4 Trough in complementary PWM mode	
TGRE_0 and TCNT_0	Compare match	TRG0N
TADCORA and TCNT_4		TRG4AN
TADCORB and TCNT_4		TRG4BN

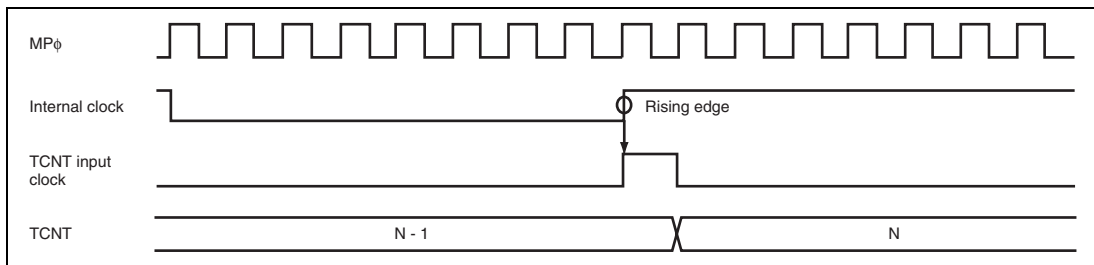
## 9.6 Operation Timing

### 9.6.1 Input/Output Timing

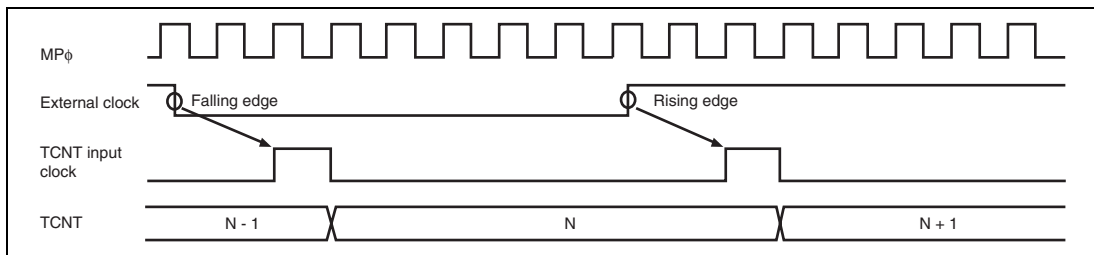
**TCNT Count Timing:** Figures 9.83 and 9.84 show TCNT count timing in internal clock operation, and figure 9.85 shows TCNT count timing in external clock operation (normal mode), and figure 9.86 shows TCNT count timing in external clock operation (phase counting mode).



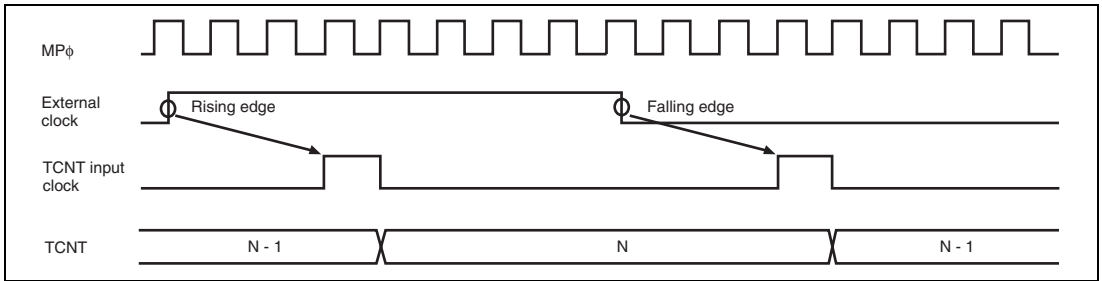
**Figure 9.83 Count Timing in Internal Clock Operation (Channels 0 to 4)**



**Figure 9.84 Count Timing in Internal Clock Operation (Channel 5)**



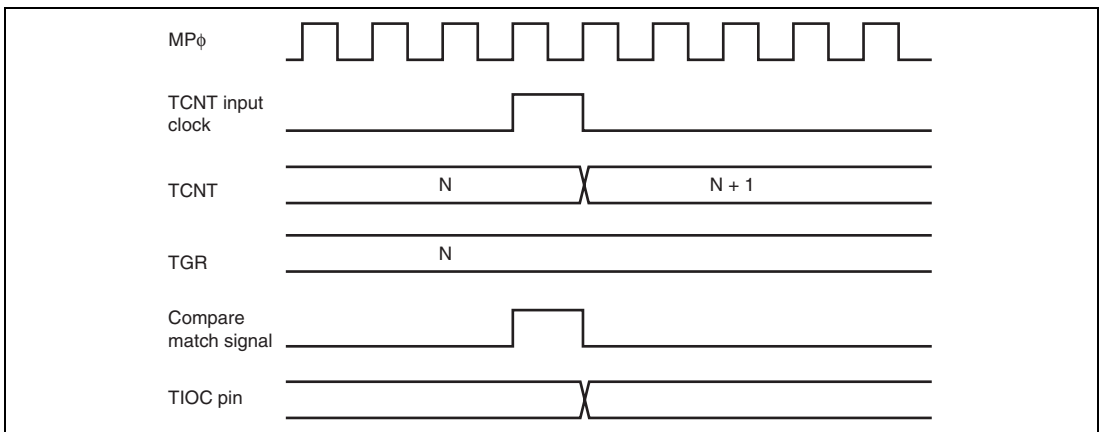
**Figure 9.85 Count Timing in External Clock Operation (Channels 0 to 4)**



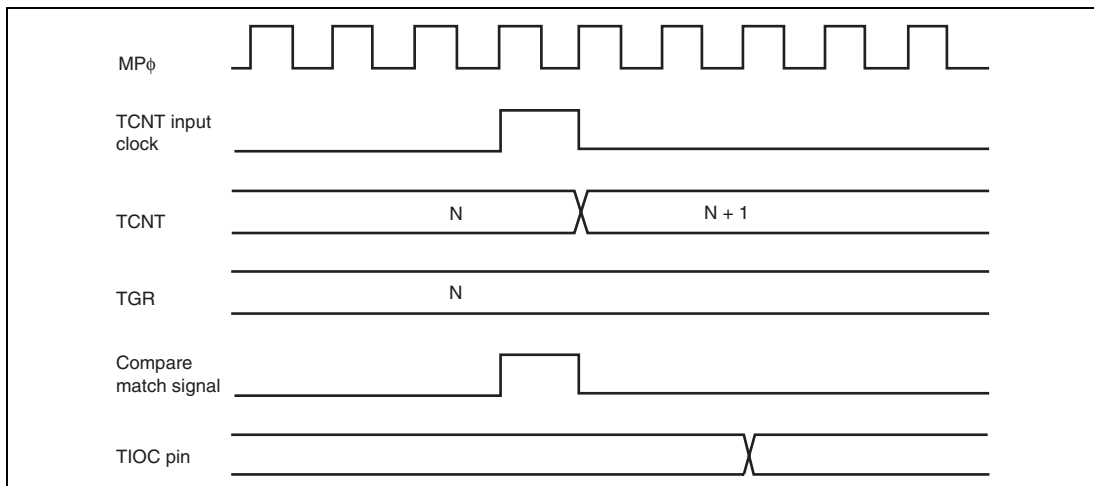
**Figure 9.86 Count Timing in External Clock Operation (Phase Counting Mode)**

**Output Compare Output Timing:** A compare match signal is generated in the final state in which TCNT and TGR match (the point at which the count value matched by TCNT is updated). When a compare match signal is generated, the output value set in TIOR is output at the output compare output pin (TIOC pin). After a match between TCNT and TGR, the compare match signal is not generated until the TCNT input clock is generated.

Figure 9.87 shows output compare output timing (normal mode and PWM mode) and figure 9.88 shows output compare output timing (complementary PWM mode and reset synchronous PWM mode).

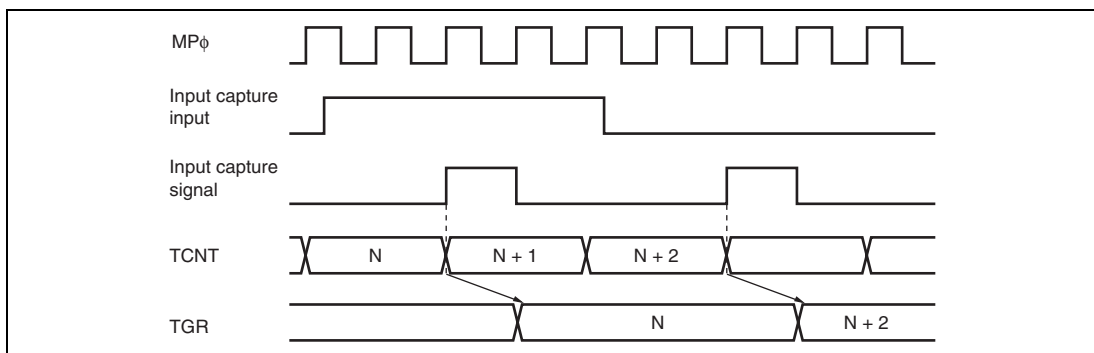


**Figure 9.87 Output Compare Output Timing (Normal Mode/PWM Mode)**



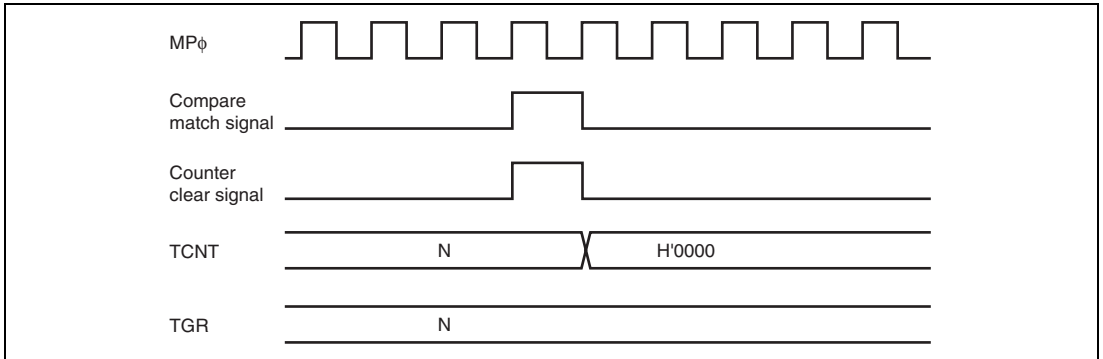
**Figure 9.88 Output Compare Output Timing  
(Complementary PWM Mode/Reset Synchronous PWM Mode)**

**Input Capture Signal Timing:** Figure 9.89 shows input capture signal timing.

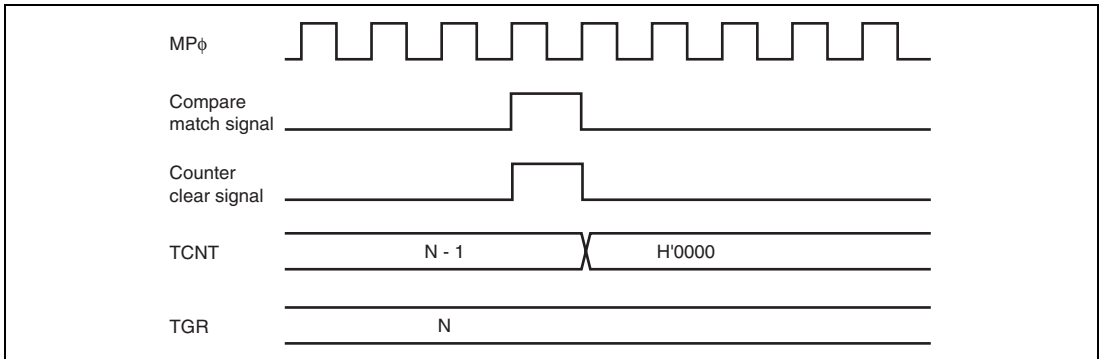


**Figure 9.89 Input Capture Input Signal Timing**

**Timing for Counter Clearing by Compare Match/Input Capture:** Figures 9.90 and 9.91 show the timing when counter clearing on compare match is specified, and figure 9.92 shows the timing when counter clearing on input capture is specified.

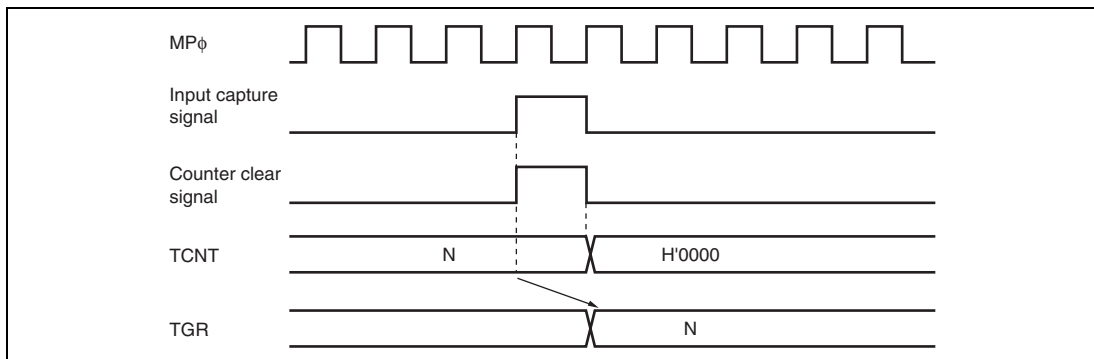


**Figure 9.90 Counter Clear Timing (Compare Match)**



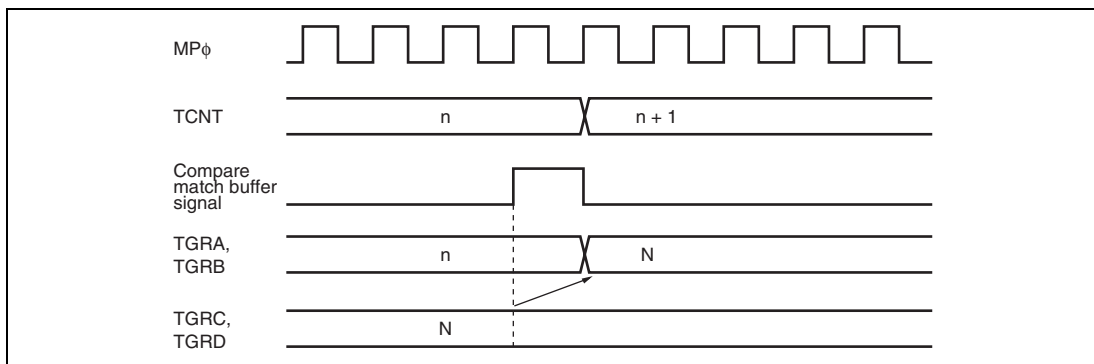
**Figure 9.91 Counter Clear Timing (Compare Match) (Channel 5)**



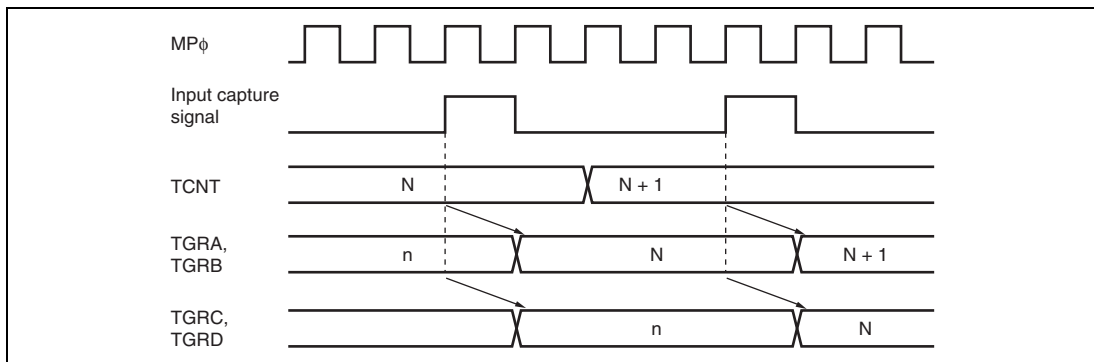


**Figure 9.92 Counter Clear Timing (Input Capture)**

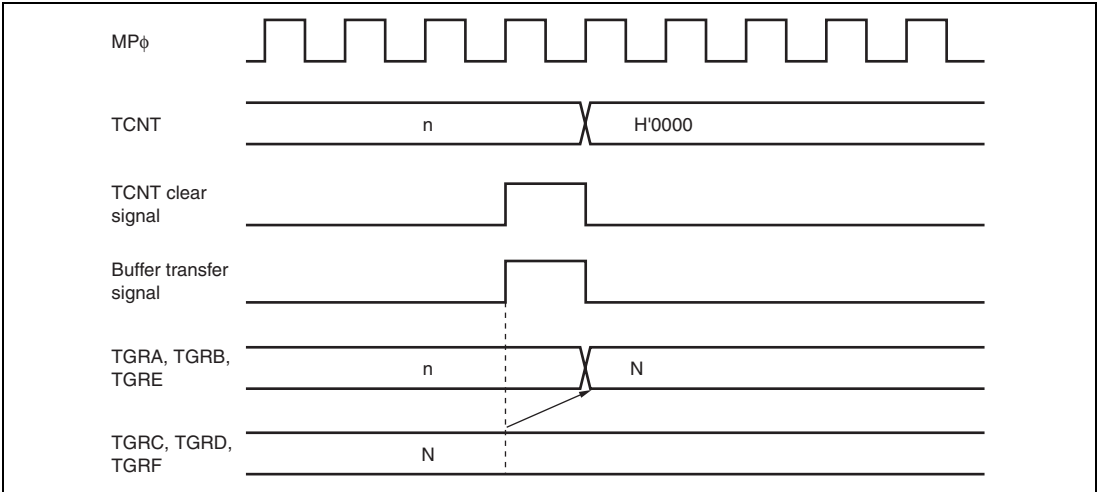
**Buffer Operation Timing:** Figures 9.93 to 9.95 show the timing in buffer operation.



**Figure 9.93 Buffer Operation Timing (Compare Match)**

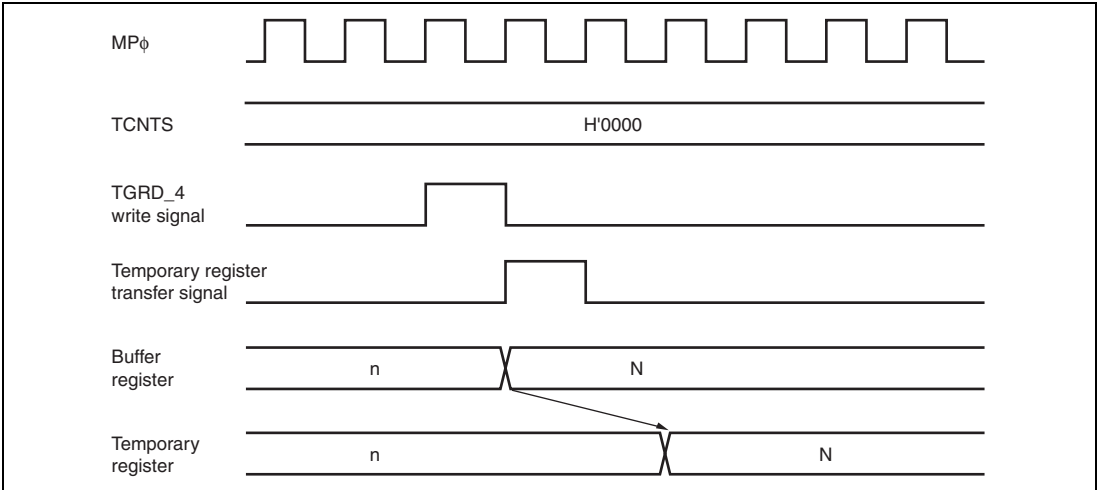


**Figure 9.94 Buffer Operation Timing (Input Capture)**

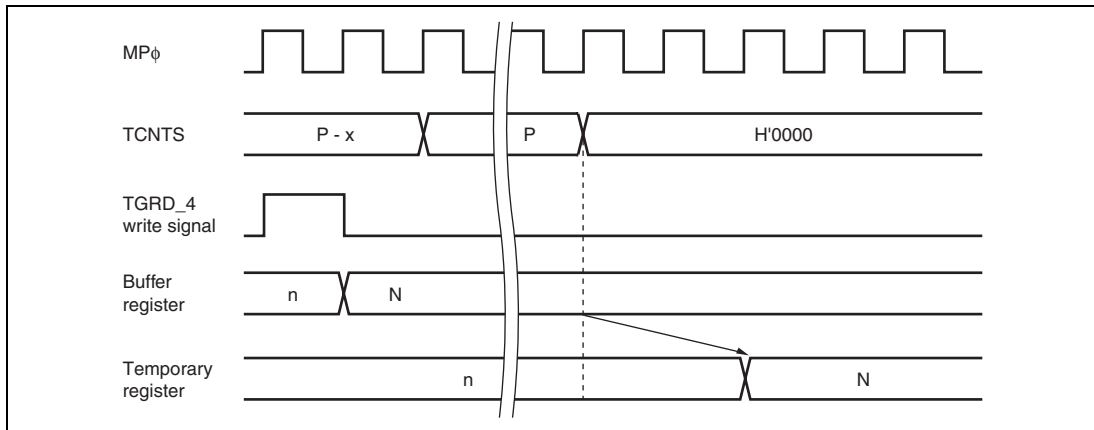


**Figure 9.95 Buffer Transfer Timing (when TCNT Cleared)**

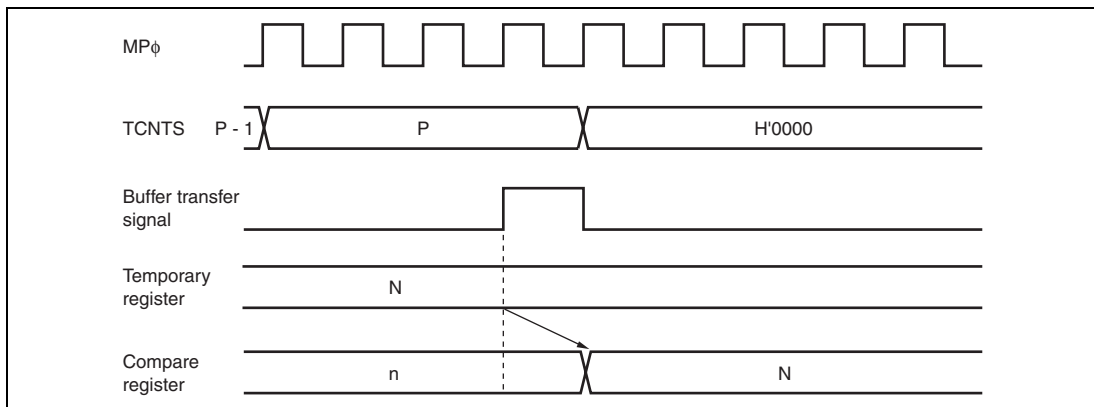
**Buffer Transfer Timing (Complementary PWM Mode):** Figures 9.96 to 9.98 show the buffer transfer timing in complementary PWM mode.



**Figure 9.96 Transfer Timing from Buffer Register to Temporary Register (TCNTS Stop)**



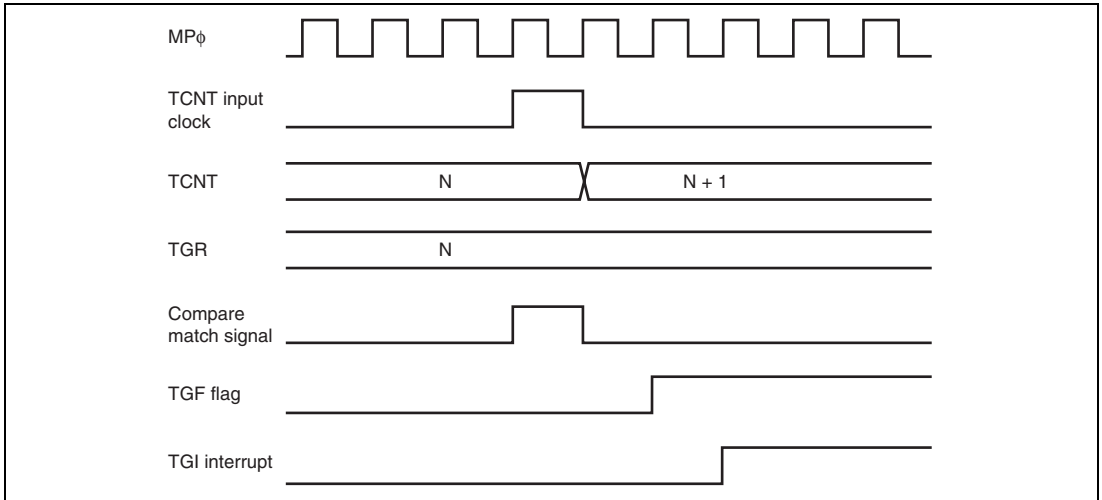
**Figure 9.97 Transfer Timing from Buffer Register to Temporary Register (TCNTS Operating)**



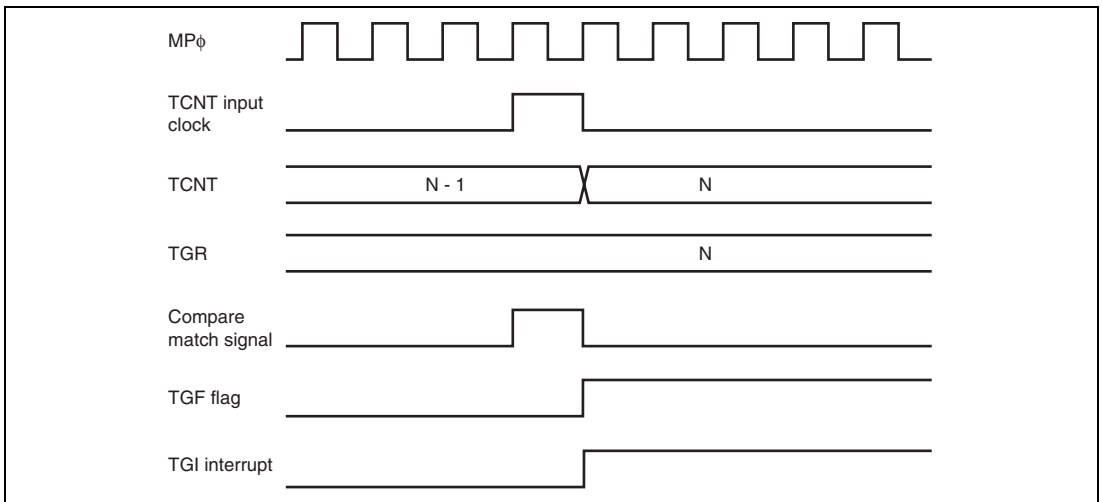
**Figure 9.98 Transfer Timing from Temporary Register to Compare Register**

## 9.6.2 Interrupt Signal Timing

**TGF Flag Setting Timing in Case of Compare Match:** Figures 9.99 and 9.100 show the timing for setting of the TGF flag in TSR on compare match, and TGI interrupt request signal timing.

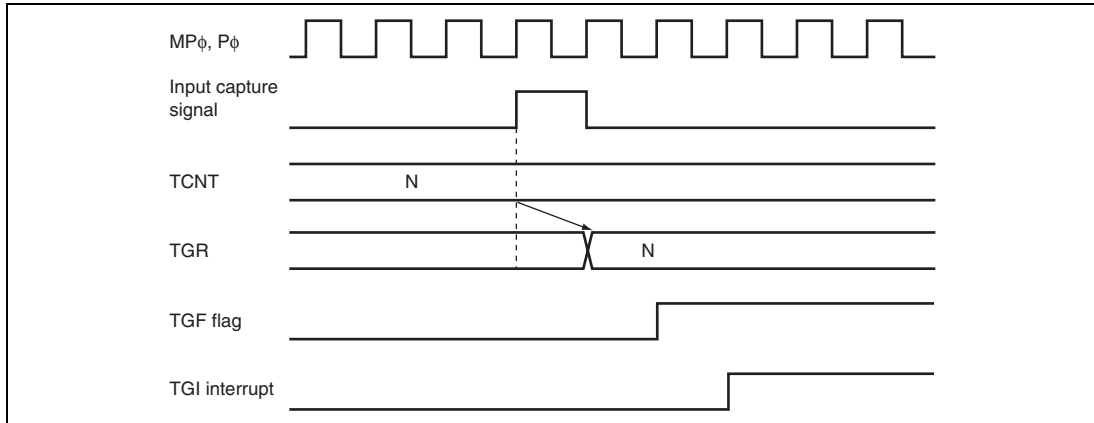


**Figure 9.99 TGI Interrupt Timing (Compare Match) (Channels 0 to 4)**

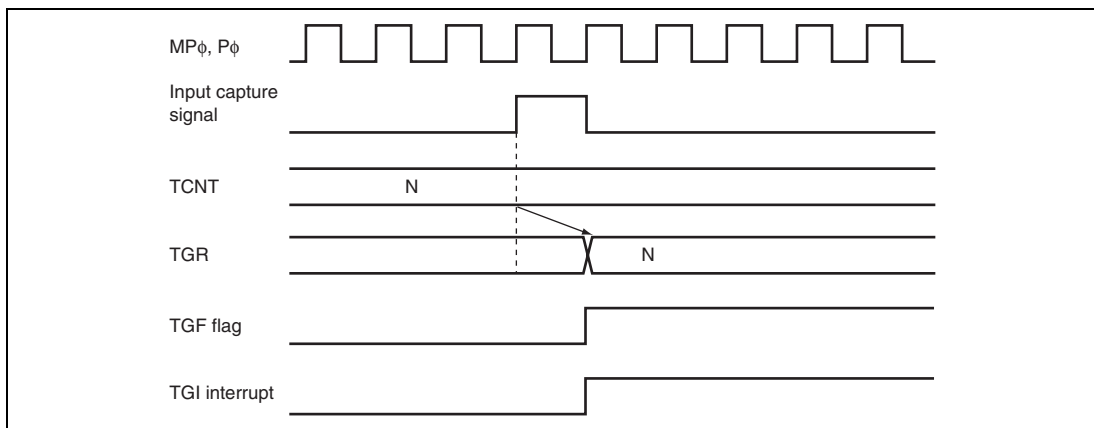


**Figure 9.100 TGI Interrupt Timing (Compare Match) (Channel 5)**

**TGF Flag Setting Timing in Case of Input Capture:** Figures 9.101 and 9.102 show the timing for setting of the TGF flag in TSR on input capture, and TGI interrupt request signal timing.



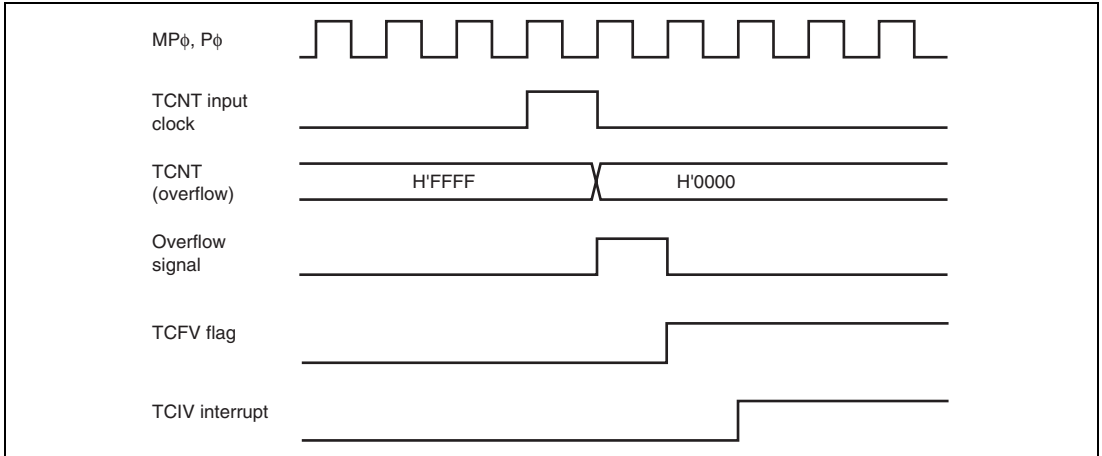
**Figure 9.101 TGI Interrupt Timing (Input Capture) (Channels 0 to 4)**



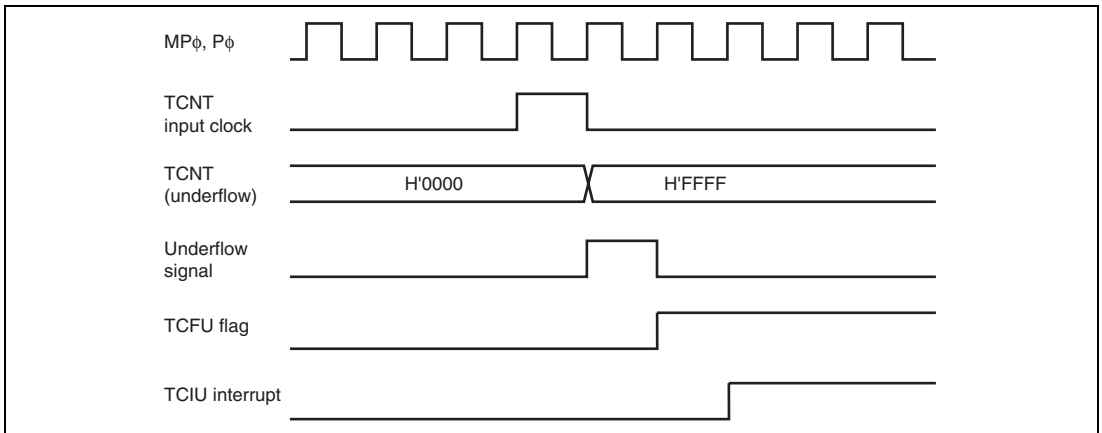
**Figure 9.102 TGI Interrupt Timing (Input Capture) (Channel 5)**

**TCFV Flag/TCFU Flag Setting Timing:** Figure 9.103 shows the timing for setting of the TCFV flag in TSR on overflow, and TCIV interrupt request signal timing.

Figure 9.104 shows the timing for setting of the TCFU flag in TSR on underflow, and TCIU interrupt request signal timing.

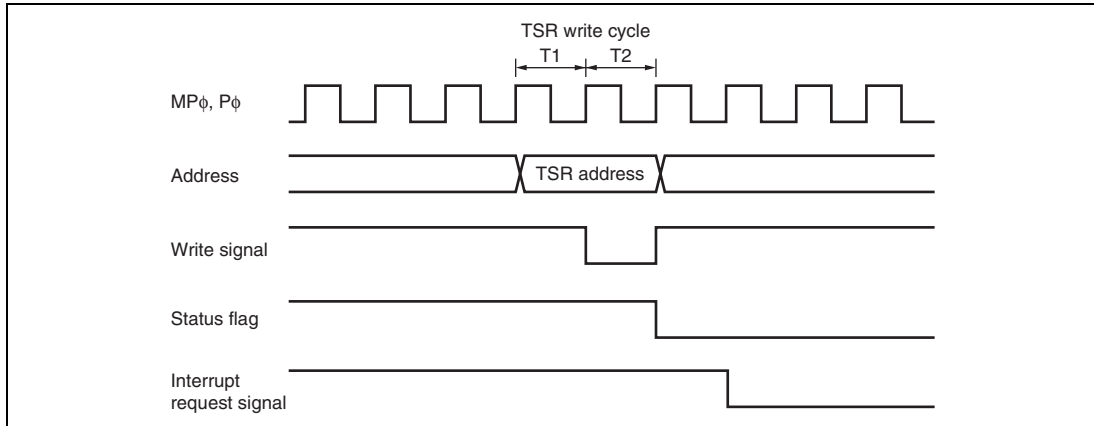


**Figure 9.103 TCIV Interrupt Setting Timing**

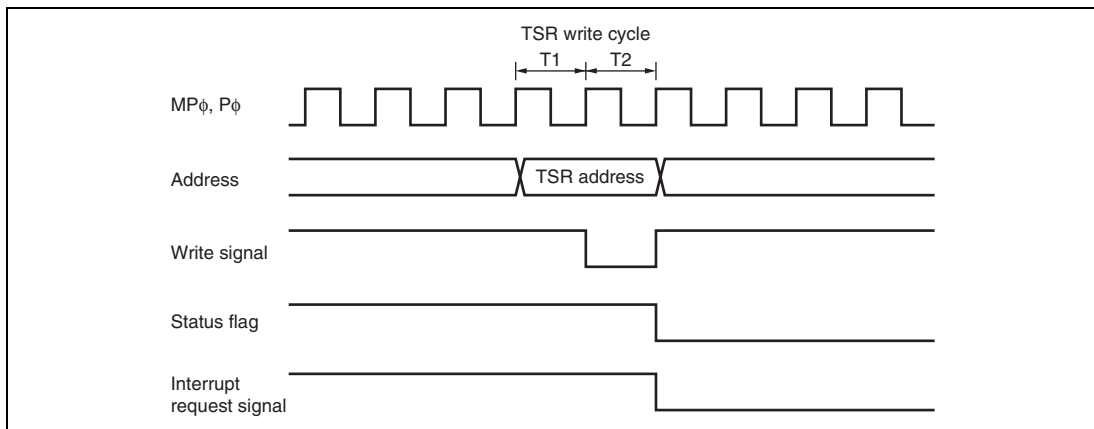


**Figure 9.104 TCIU Interrupt Setting Timing**

**Status Flag Clearing Timing:** After a status flag is read as 1 by the CPU, it is cleared by writing 0 to it. Figures 9.105 and 9.106 show the timing for status flag clearing by the CPU.



**Figure 9.105 Timing for Status Flag Clearing by CPU (Channels 0 to 4)**



**Figure 9.106 Timing for Status Flag Clearing by CPU (Channel 5)**

## 9.7 Usage Notes

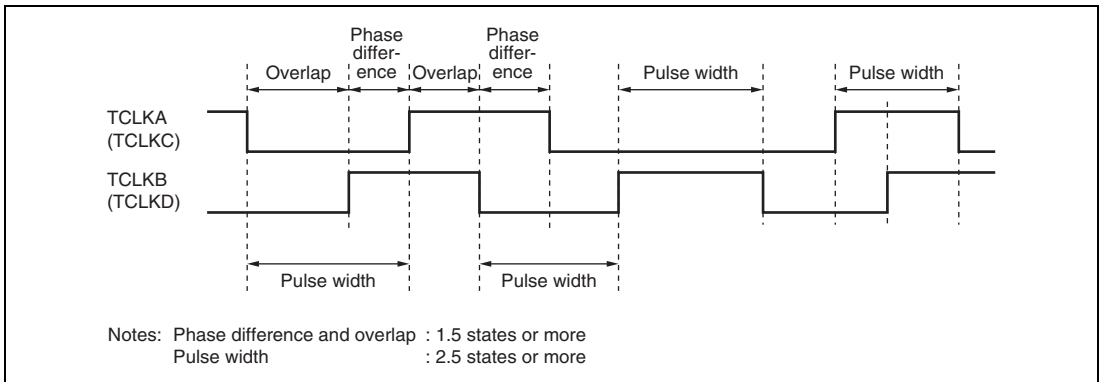
### 9.7.1 Module Standby Mode Setting

MTU2 operation can be disabled or enabled using the standby control register. The initial setting is for MTU2 operation to be halted. Register access is enabled by clearing module standby mode. For details, refer to section 19, Power-Down Modes.

### 9.7.2 Input Clock Restrictions

The input clock pulse width must be at least 1.5 states in the case of single-edge detection, and at least 2.5 states in the case of both-edge detection. The MTU2 will not operate properly at narrower pulse widths.

In phase counting mode, the phase difference and overlap between the two input clocks must be at least 1.5 states, and the pulse width must be at least 2.5 states. Figure 9.107 shows the input clock conditions in phase counting mode.



**Figure 9.107 Phase Difference, Overlap, and Pulse Width in Phase Counting Mode**



### 9.7.3 Caution on Period Setting

When counter clearing on compare match is set, TCNT is cleared in the final state in which it matches the TGR value (the point at which the count value matched by TCNT is updated). Consequently, the actual counter frequency is given by the following formula:

- Channels 0 to 4

$$f = \frac{MP\phi}{(N + 1)}$$

- Channel 5

$$f = \frac{MP\phi}{N}$$

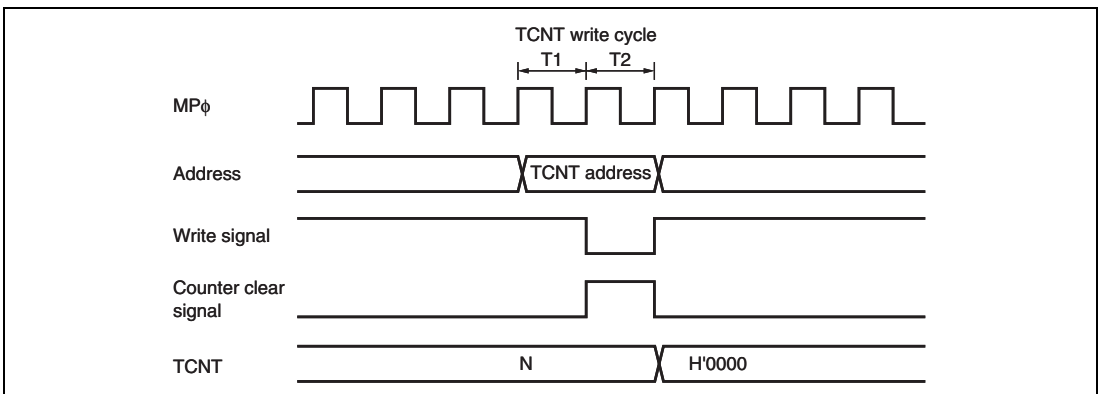
Where

- f: Counter frequency
- MP $\phi$ : MTU2 peripheral clock operating frequency
- N: TGR set value

### 9.7.4 Contention between TCNT Write and Clear Operations

If the counter clear signal is generated in the T2 state of a TCNT write cycle, TCNT clearing takes precedence and the TCNT write is not performed.

Figure 9.108 shows the timing in this case.

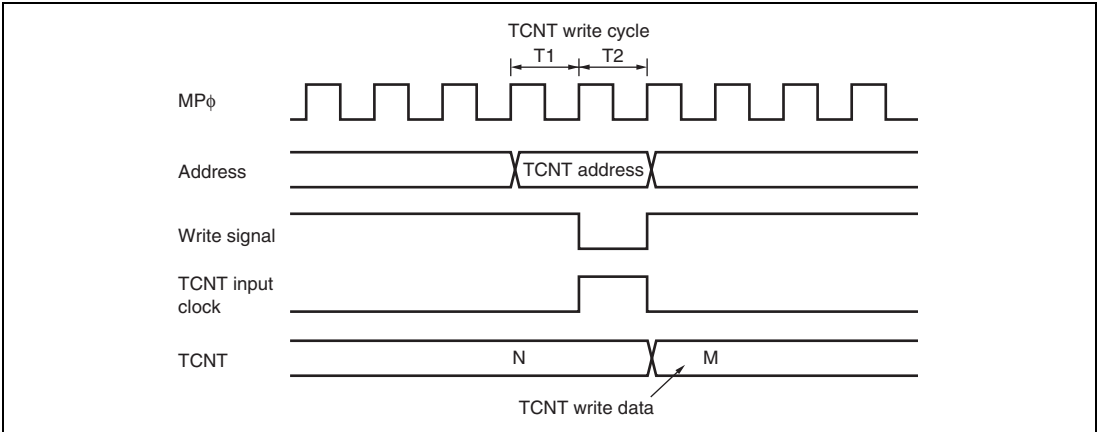


**Figure 9.108 Contention between TCNT Write and Clear Operations**

### 9.7.5 Contention between TCNT Write and Increment Operations

If incrementing occurs in the T2 state of a TCNT write cycle, the TCNT write takes precedence and TCNT is not incremented.

Figure 9.109 shows the timing in this case.

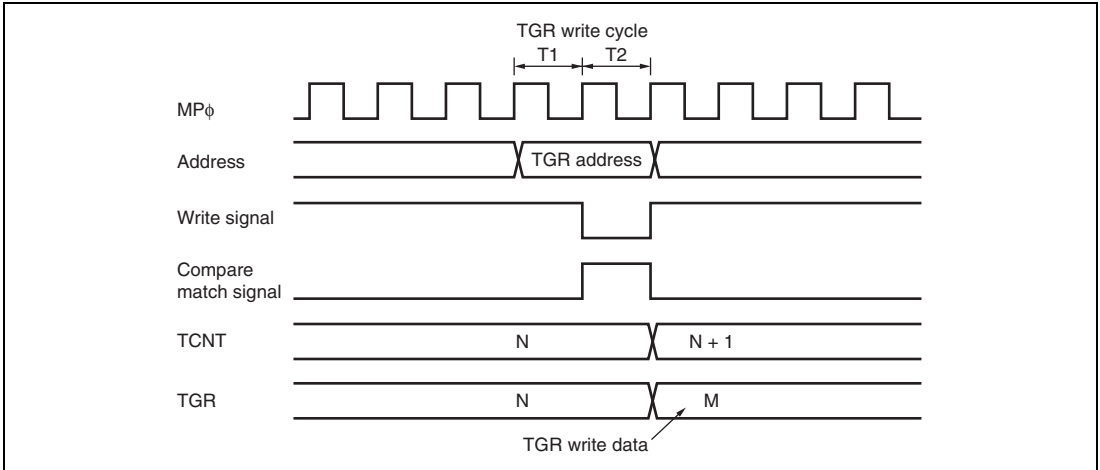


**Figure 9.109** Contention between TCNT Write and Increment Operations

### 9.7.6 Contention between TGR Write and Compare Match

If a compare match occurs in the T2 state of a TGR write cycle, the TGR write is executed and the compare match signal is also generated.

Figure 9.110 shows the timing in this case.

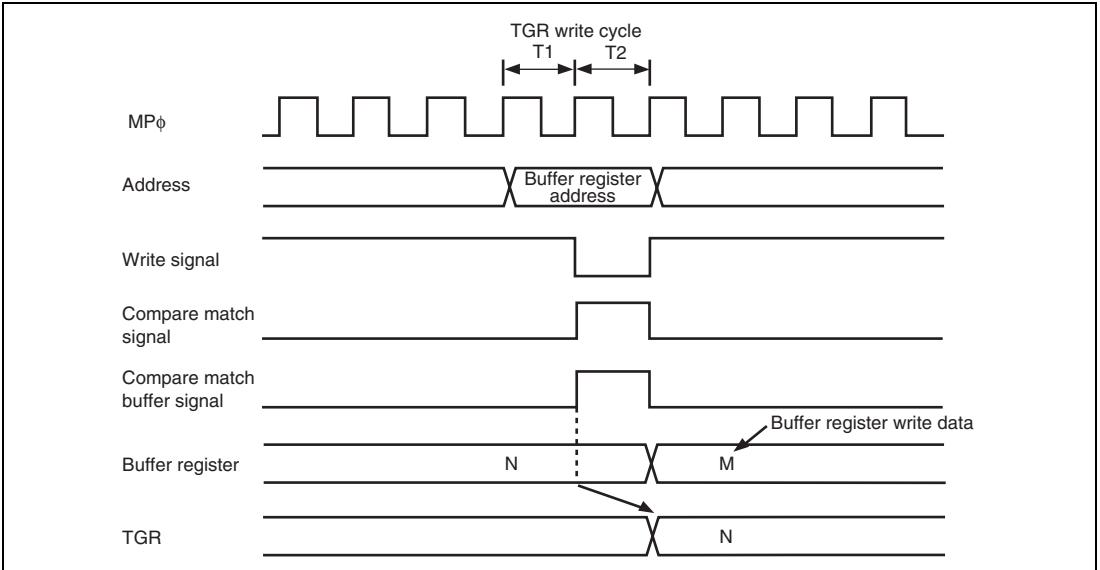


**Figure 9.110 Contention between TGR Write and Compare Match**

### 9.7.7 Contention between Buffer Register Write and Compare Match

If a compare match occurs in the T2 state of a TGR write cycle, the data that is transferred to TGR by the buffer operation is the data before write.

Figure 9.111 shows the timing in this case.

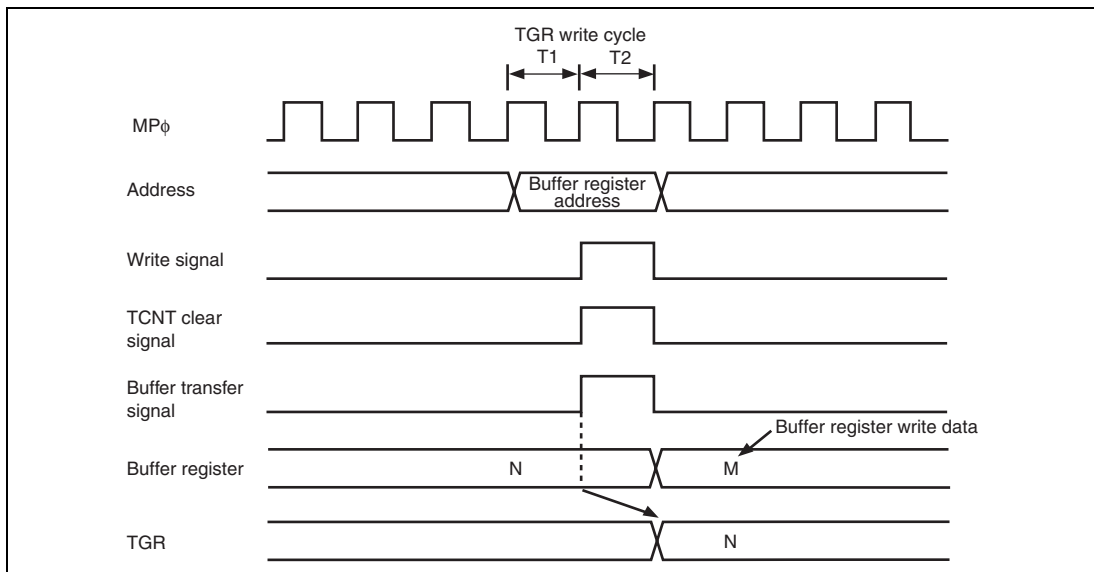


**Figure 9.111 Contention between Buffer Register Write and Compare Match**

### 9.7.8 Contention between Buffer Register Write and TCNT Clear

When the buffer transfer timing is set at the TCNT clear by the buffer transfer mode register (TBTM), if TCNT clear occurs in the T2 state of a TGR write cycle, the data that is transferred to TGR by the buffer operation is the data before write.

Figure 9.112 shows the timing in this case.

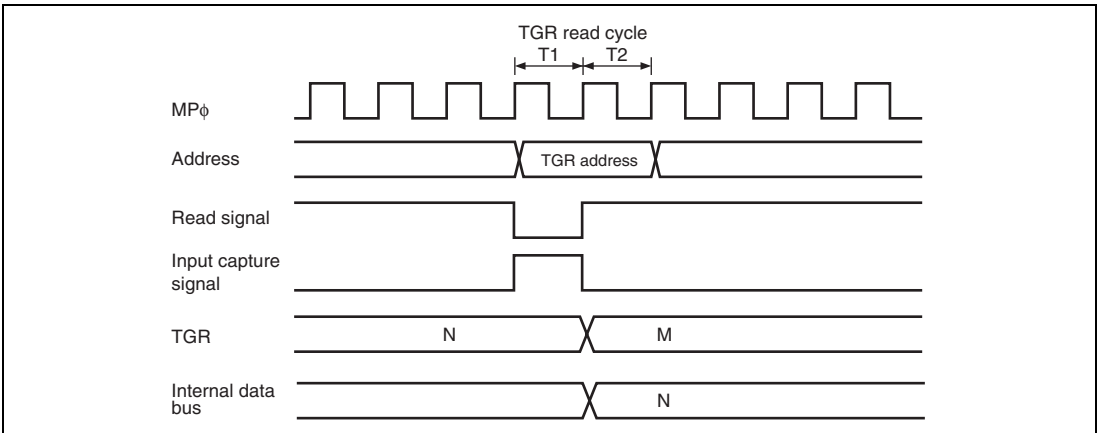


**Figure 9.112 Contention between Buffer Register Write and TCNT Clear**

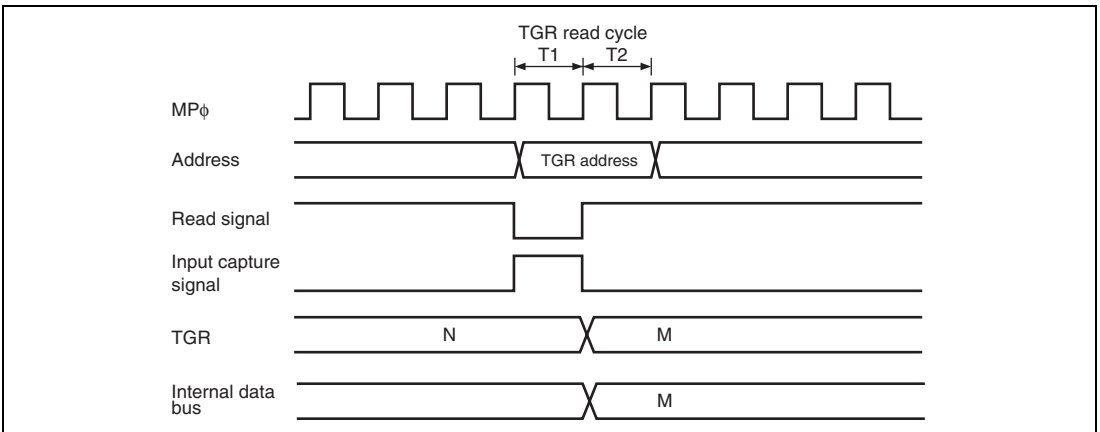
### 9.7.9 Contention between TGR Read and Input Capture

If an input capture signal is generated in the T1 state of a TGR read cycle, the data that is read will be the data in the buffer before input capture transfer for channels 0 to 4, and the data after input capture transfer for channel 5.

Figures 9.113 and 9.114 show the timing in this case.



**Figure 9.113 Contention between TGR Read and Input Capture (Channels 0 to 4)**

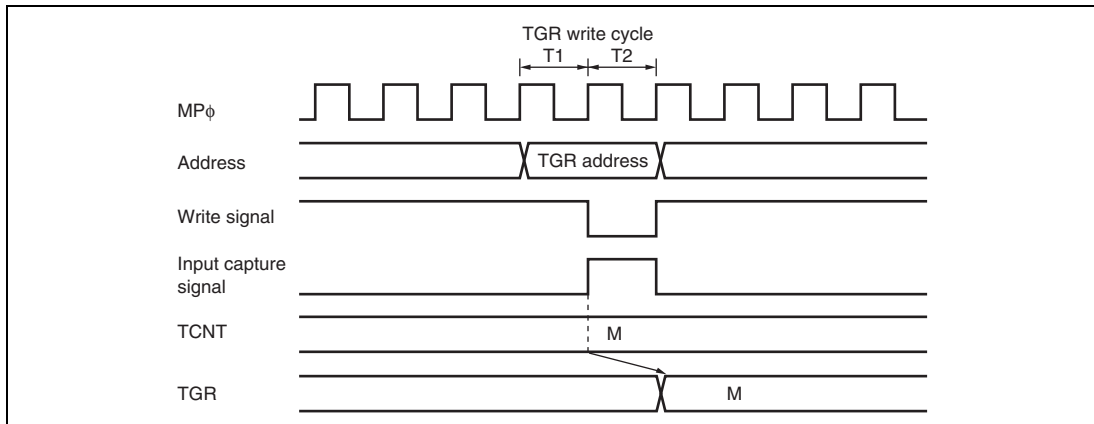


**Figure 9.114 Contention between TGR Read and Input Capture (Channel 5)**

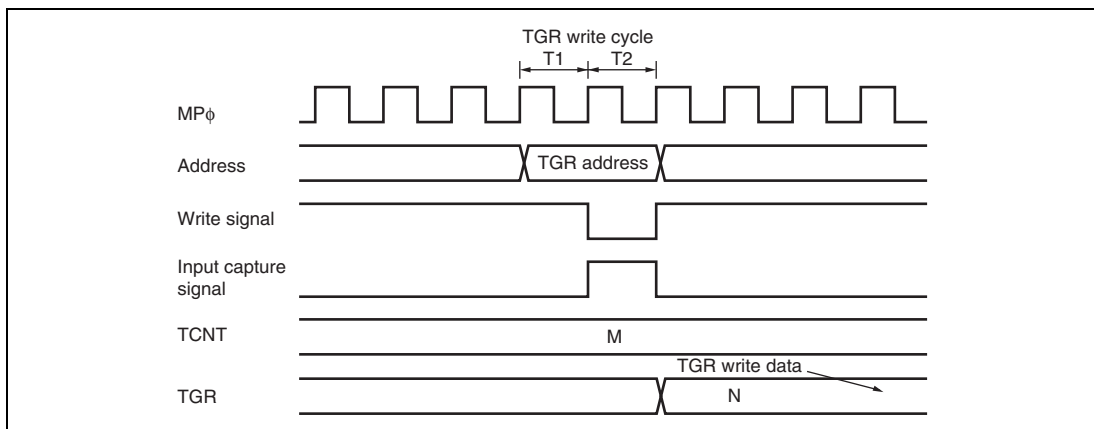
### 9.7.10 Contention between TGR Write and Input Capture

If an input capture signal is generated in the T2 state of a TGR write cycle, the input capture operation takes precedence and the write to TGR is not performed for channels 0 to 4. For channel 5, write to TGR is performed and the input capture signal is generated.

Figures 9.115 and 9.116 show the timing in this case.



**Figure 9.115 Contention between TGR Write and Input Capture (Channels 0 to 4)**

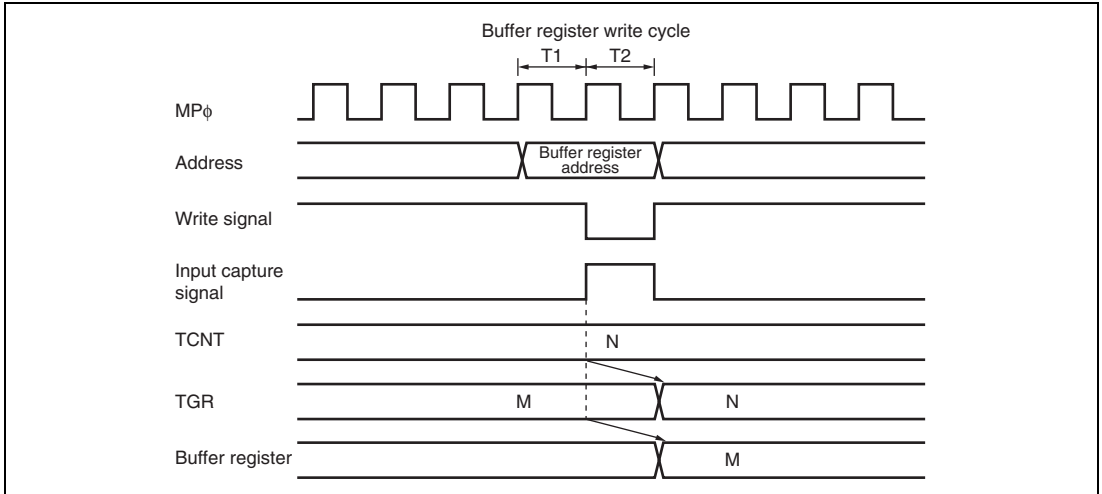


**Figure 9.116 Contention between TGR Write and Input Capture (Channel 5)**

### 9.7.11 Contention between Buffer Register Write and Input Capture

If an input capture signal is generated in the T2 state of a buffer register write cycle, the buffer operation takes precedence and the write to the buffer register is not performed.

Figure 9.117 shows the timing in this case.



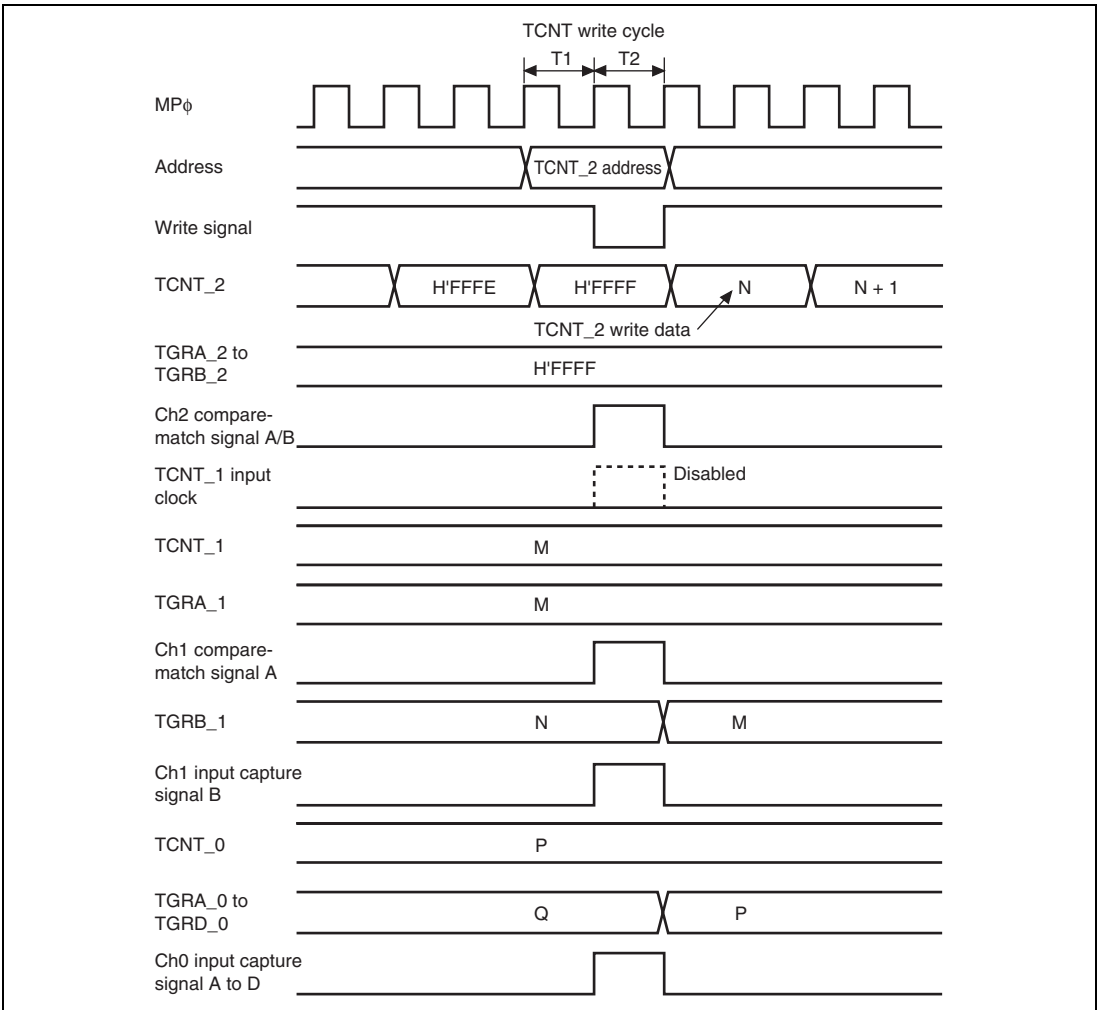
**Figure 9.117 Contention between Buffer Register Write and Input Capture**

### 9.7.12 TCNT\_2 Write and Overflow/Underflow Contention in Cascade Connection

With timer counters TCNT\_1 and TCNT\_2 in a cascade connection, when a contention occurs during TCNT\_1 count (during a TCNT\_2 overflow/underflow) in the T2 state of the TCNT\_2 write cycle, the write to TCNT\_2 is conducted, and the TCNT\_1 count signal is disabled. At this point, if there is match with TGRA\_1 and the TCNT\_1 value, a compare signal is issued. Furthermore, when the TCNT\_1 count clock is selected as the input capture source of channel 0, TGRA\_0 to TGRD\_0 carry out the input capture operation. In addition, when the compare match/input capture is selected as the input capture source of TGRB\_1, TGRB\_1 carries out input capture operation. The timing is shown in figure 9.118.

For cascade connections, be sure to synchronize settings for channels 1 and 2 when setting TCNT clearing.





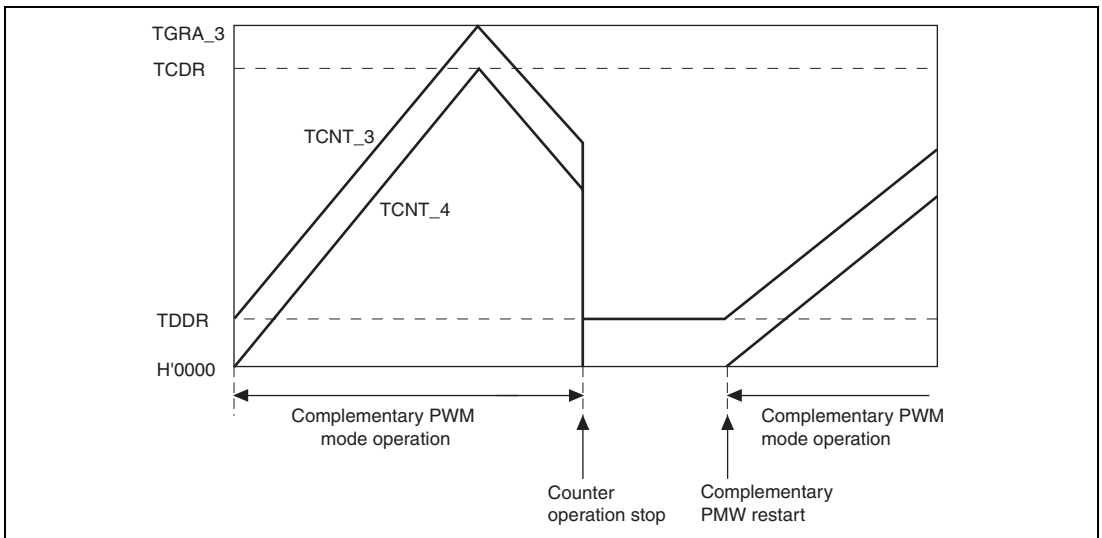
**Figure 9.118 TCNT\_2 Write and Overflow/Underflow Contention with Cascade Connection**

### 9.7.13 Counter Value during Complementary PWM Mode Stop

When counting operation is suspended with TCNT\_3 and TCNT\_4 in complementary PWM mode, TCNT\_3 has the timer dead time register (TDDR) value, and TCNT\_4 is held at H'0000.

When restarting complementary PWM mode, counting begins automatically from the initialized state. This explanatory diagram is shown in figure 9.119.

When counting begins in another operating mode, be sure that TCNT\_3 and TCNT\_4 are set to the initial values.



**Figure 9.119 Counter Value during Complementary PWM Mode Stop**

### 9.7.14 Buffer Operation Setting in Complementary PWM Mode

In complementary PWM mode, conduct rewrites by buffer operation for the PWM cycle setting register (TGRA\_3), timer cycle data register (TCDR), and duty setting registers (TGRB\_3, TGRA\_4, and TGRB\_4).

In complementary PWM mode, channel 3 and channel 4 buffers operate in accordance with bit settings BFA and BFB of TMDR\_3. When the BFA bit in TMDR\_3 is set to 1, TGRC\_3 functions as a buffer register for TGRA\_3. At the same time, TGRC\_4 functions as the buffer register for TGRA\_4, and TCBR functions as the TCDR's buffer register.

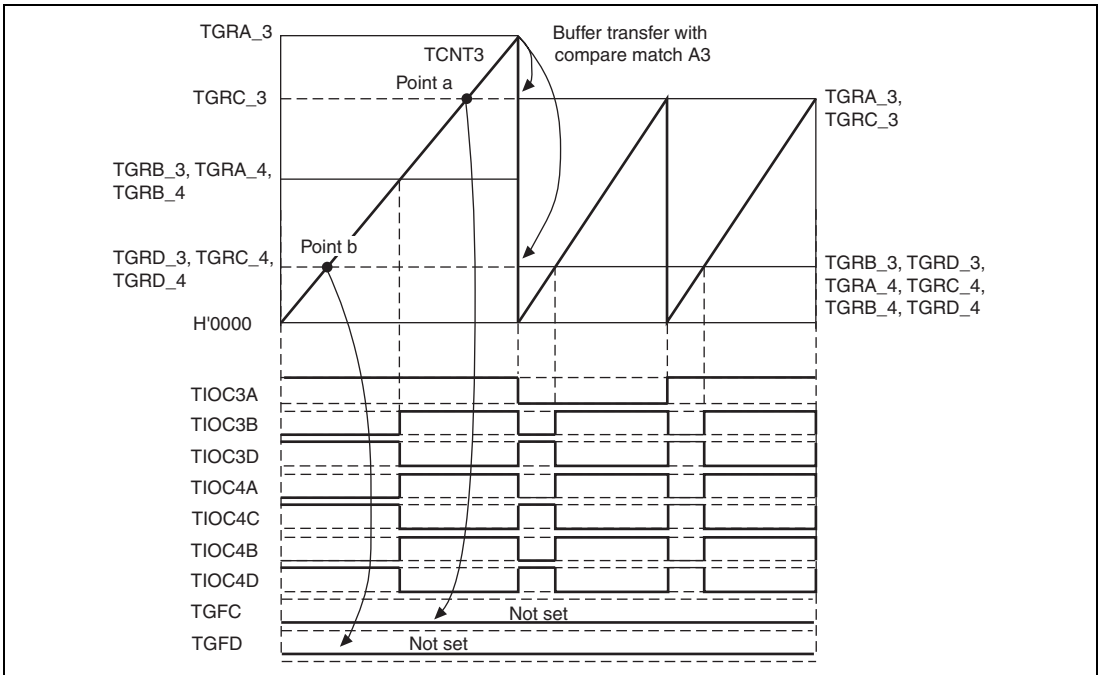
### 9.7.15 Reset Sync PWM Mode Buffer Operation and Compare Match Flag

When setting buffer operation for reset sync PWM mode, set the BFA and BFB bits in TMDR\_4 to 0. The TIOC4C pin will be unable to produce its waveform output if the BFA bit in TMDR\_4 is set to 1.

In reset sync PWM mode, the channel 3 and channel 4 buffers operate in accordance with the BFA and BFB bit settings of TMDR\_3. For example, if the BFA bit in TMDR\_3 is set to 1, TGRC\_3 functions as the buffer register for TGRA\_3. At the same time, TGRC\_4 functions as the buffer register for TGRA\_4.

The TGFC bit and TGFD bit in TSR\_3 and TSR\_4 are not set when TGRC\_3 and TGRD\_3 are operating as buffer registers.

Figure 9.120 shows an example of operations for TGR\_3, TGR\_4, TIOC3, and TIOC4, with TMDR\_3's BFA and BFB bits set to 1, and TMDR\_4's BFA and BFB bits set to 0.



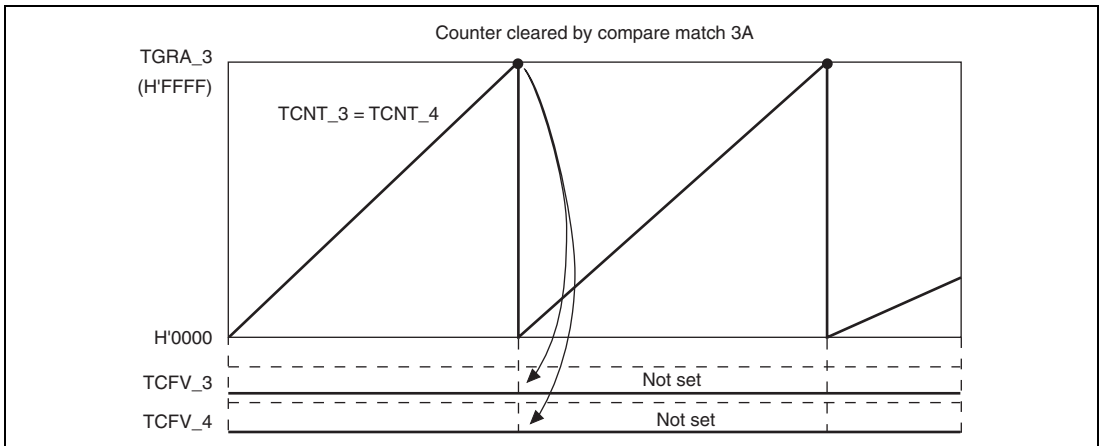
**Figure 9.120 Buffer Operation and Compare-Match Flags  
in Reset Synchronous PWM Mode**

### 9.7.16 Overflow Flags in Reset Synchronous PWM Mode

When set to reset synchronous PWM mode, TCNT\_3 and TCNT\_4 start counting when the CST3 bit in TSTR is set to 1. At this point, TCNT\_4's count clock source and count edge obey the TCR\_3 setting.

In reset synchronous PWM mode, with cycle register TGRA\_3's set value at H'FFFF, when specifying TGR3A compare-match for the counter clear source, TCNT\_3 and TCNT\_4 count up to H'FFFF, then a compare-match occurs with TGRA\_3, and TCNT\_3 and TCNT\_4 are both cleared. At this point, TSR's overflow flag TCFV bit is not set.

Figure 9.121 shows a TCFV bit operation example in reset synchronous PWM mode with a set value for cycle register TGRA\_3 of H'FFFF, when a TGRA\_3 compare-match has been specified without synchronous setting for the counter clear source.

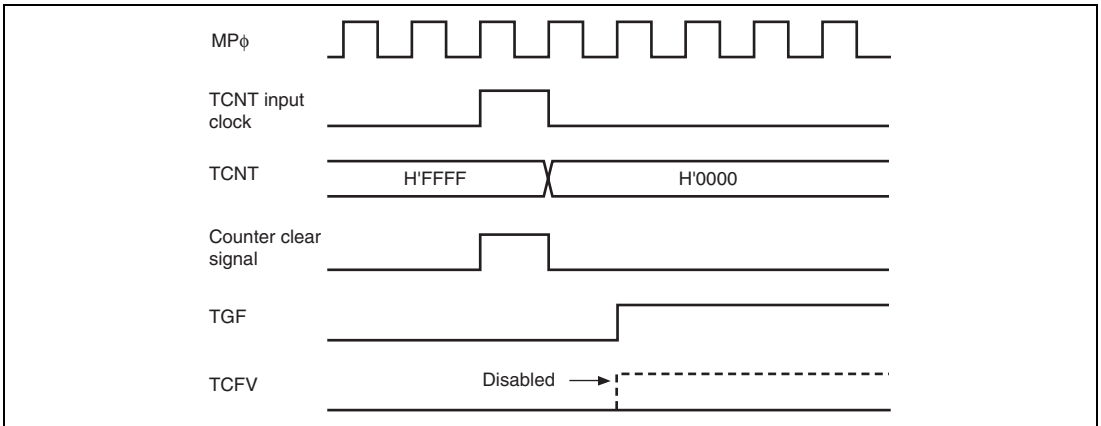


**Figure 9.121 Reset Synchronous PWM Mode Overflow Flag**

### 9.7.17 Contention between Overflow/Underflow and Counter Clearing

If overflow/underflow and counter clearing occur simultaneously, the TCFV/TCFU flag in TSR is not set and TCNT clearing takes precedence.

Figure 9.122 shows the operation timing when a TGR compare match is specified as the clearing source, and when H'FFFF is set in TGR.

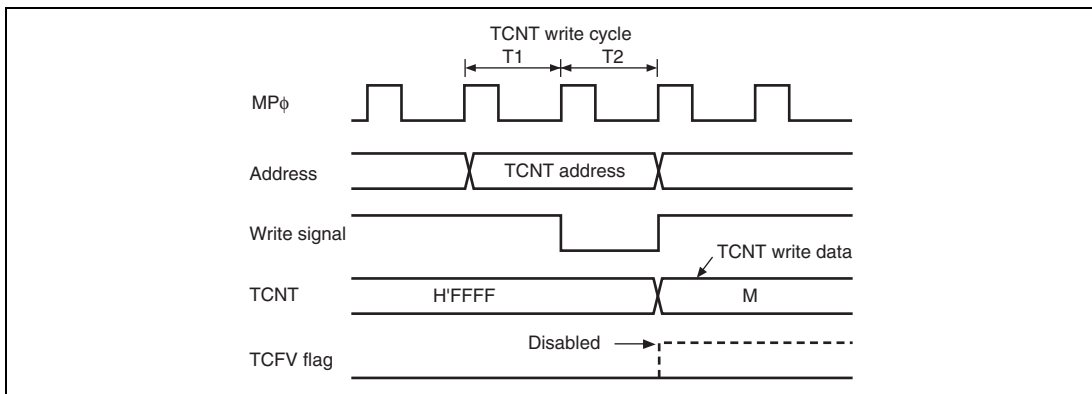


**Figure 9.122 Contention between Overflow and Counter Clearing**

### 9.7.18 Contention between TCNT Write and Overflow/Underflow

If there is an up-count or down-count in the T2 state of a TCNT write cycle, and overflow/underflow occurs, the TCNT write takes precedence and the TCFV/TCFU flag in TSR is not set.

Figure 9.123 shows the operation timing when there is contention between TCNT write and overflow.



**Figure 9.123 Contention between TCNT Write and Overflow**

### 9.7.19 Cautions on Transition from Normal Operation or PWM Mode 1 to Reset-Synchronized PWM Mode

When making a transition from channel 3 or 4 normal operation or PWM mode 1 to reset-synchronized PWM mode, if the counter is halted with the output pins (TIOC3B, TIOC3D, TIOC4A, TIOC4C, TIOC4B, TIOC4D) in the high-level state, followed by the transition to reset-synchronized PWM mode and operation in that mode, the initial pin output will not be correct.

When making a transition from normal operation to reset-synchronized PWM mode, write H'11 to registers TIORH\_3, TIORL\_3, TIORH\_4, and TIORL\_4 to initialize the output pins to low level output, then set an initial register value of H'00 before making the mode transition.

When making a transition from PWM mode 1 to reset-synchronized PWM mode, first switch to normal operation, then initialize the output pins to low level output and set an initial register value of H'00 before making the transition to reset-synchronized PWM mode.

### 9.7.20 Output Level in Complementary PWM Mode and Reset-Synchronized PWM Mode

When channels 3 and 4 are in complementary PWM mode or reset-synchronized PWM mode, the PWM waveform output level is set with the OLSP and OLSN bits in the timer output control register (TOCR). In the case of complementary PWM mode or reset-synchronized PWM mode, TIOR should be set to H'00.

### 9.7.21 Interrupts in Module Standby Mode

If module standby mode is entered when an interrupt has been requested, it will not be possible to clear the CPU interrupt source. Interrupts should therefore be disabled before entering module standby mode.

### 9.7.22 Simultaneous Capture of TCNT\_1 and TCNT\_2 in Cascade Connection

When timer counters 1 and 2 (TCNT\_1 and TCNT\_2) are operated as a 32-bit counter in cascade connection, the cascade counter value cannot be captured successfully even if input-capture input is simultaneously done to TIOC1A and TIOC2A or to TIOC1B and TIOC2B. This is because the input timing of TIOC1A and TIOC2A or of TIOC1B and TIOC2B may not be the same when external input-capture signals to be input into TCNT\_1 and TCNT\_2 are taken in synchronization with the internal clock. For example, TCNT\_1 (the counter for upper 16 bits) does not capture the count-up value by overflow from TCNT\_2 (the counter for lower 16 bits) but captures the count value before the count-up. In this case, the values of TCNT\_1 = H'FFF1 and TCNT\_2 = H'0000 should be transferred to TGRA\_1 and TGRA\_2 or to TGRB\_1 and TGRB\_2, but the values of TCNT\_1 = H'FFF0 and TCNT\_2 = H'0000 are erroneously transferred.

The MTU2 has a new function that allows simultaneous capture of TCNT\_1 and TCNT\_2 with a single input-capture input as the trigger. This function allows reading of the 32-bit counter such that TCNT\_1 and TCNT\_2 are captured at the same time.

## 9.8 MTU2 Output Pin Initialization

### 9.8.1 Operating Modes

The MTU2 has the following six operating modes. Waveform output is possible in all of these modes.

- Normal mode (channels 0 to 4)
- PWM mode 1 (channels 0 to 4)
- PWM mode 2 (channels 0 to 2)
- Phase counting modes 1 to 4 (channels 1 and 2)
- Complementary PWM mode (channels 3 and 4)
- Reset-synchronized PWM mode (channels 3 and 4)

The MTU2 output pin initialization method for each of these modes is described in this section.

### 9.8.2 Reset Start Operation

The MTU2 output pins (TIOC\*) are initialized low by a reset and in standby mode. Since MTU2 pin function selection is performed by the pin function controller (PFC), when the PFC is set, the MTU2 pin states at that point are output to the ports. When MTU2 output is selected by the PFC immediately after a reset, the MTU2 output initial level, low, is output directly at the port. When the active level is low, the system will operate at this point, and therefore the PFC setting should be made after initialization of the MTU2 output pins is completed.

Note: Channel number and port notation are substituted for \*.



### 9.8.3 Operation in Case of Re-Setting Due to Error During Operation, etc.

If an error occurs during MTU2 operation, MTU2 output should be cut by the system. Cutoff is performed by switching the pin output to port output with the PFC and outputting the inverse of the active level. For large-current pins, output can also be cut by hardware, using port output enable (POE). The pin initialization procedures for re-setting due to an error during operation, etc., and the procedures for restarting in a different mode after re-setting, are shown below.

The MTU2 has six operating modes, as stated above. There are thus 36 mode transition combinations, but some transitions are not available with certain channel and mode combinations. Possible mode transition combinations are shown in table 9.59.

**Table 9.59 Mode Transition Combinations**

Before	After					
	Normal	PWM1	PWM2	PCM	CPWM	RPWM
Normal	(1)	(2)	(3)	(4)	(5)	(6)
PWM1	(7)	(8)	(9)	(10)	(11)	(12)
PWM2	(13)	(14)	(15)	(16)	None	None
PCM	(17)	(18)	(19)	(20)	None	None
CPWM	(21)	(22)	None	None	(23) (24)	(25)
RPWM	(26)	(27)	None	None	(28)	(29)

[Legend]

Normal: Normal mode

PWM1: PWM mode 1

PWM2: PWM mode 2

PCM: Phase counting modes 1 to 4

CPWM: Complementary PWM mode

RPWM: Reset-synchronized PWM mode

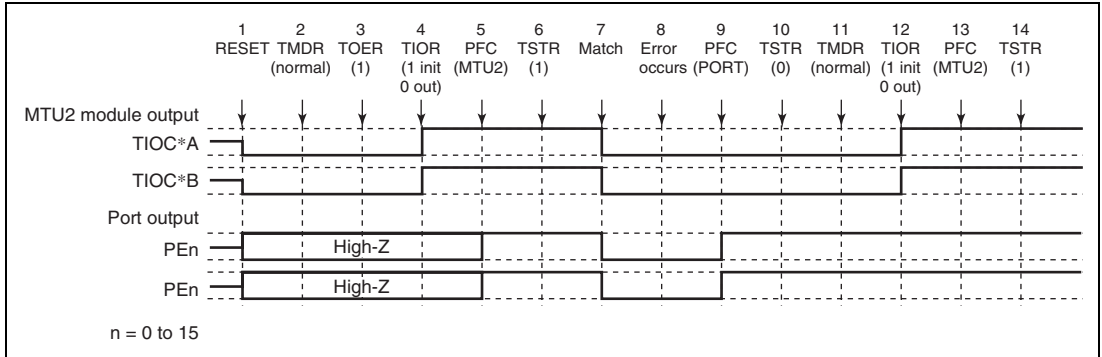
#### 9.8.4 Overview of Initialization Procedures and Mode Transitions in Case of Error during Operation, etc.

- When making a transition to a mode (Normal, PWM1, PWM2, PCM) in which the pin output level is selected by the timer I/O control register (TIOR) setting, initialize the pins by means of a TIOR setting.
- In PWM mode 1, since a waveform is not output to the TIOC\*B (TIOC \*D) pin, setting TIOR will not initialize the pins. If initialization is required, carry it out in normal mode, then switch to PWM mode 1.
- In PWM mode 2, since a waveform is not output to the cycle register pin, setting TIOR will not initialize the pins. If initialization is required, carry it out in normal mode, then switch to PWM mode 2.
- In normal mode or PWM mode 2, if TGRC and TGRD operate as buffer registers, setting TIOR will not initialize the buffer register pins. If initialization is required, clear buffer mode, carry out initialization, then set buffer mode again.
- In PWM mode 1, if either TGRC or TGRD operates as a buffer register, setting TIOR will not initialize the TGRC pin. To initialize the TGRC pin, clear buffer mode, carry out initialization, then set buffer mode again.
- When making a transition to a mode (CPWM, RPWM) in which the pin output level is selected by the timer output control register (TOCR) setting, switch to normal mode and perform initialization with TIOR, then restore TIOR to its initial value, and temporarily disable channel 3 and 4 output with the timer output master enable register (TOER). Then operate the unit in accordance with the mode setting procedure (TOCR setting, TMDR setting, TOER setting).

Note: Channel number is substituted for \* indicated in this article.

Pin initialization procedures are described below for the numbered combinations in table 9.59. The active level is assumed to be low.

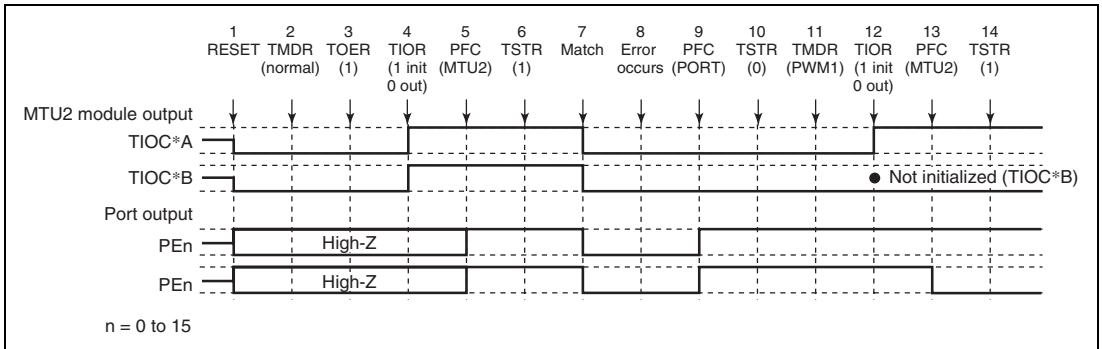
**Operation when Error Occurs during Normal Mode Operation, and Operation is Restarted in Normal Mode:** Figure 9.124 shows an explanatory diagram of the case where an error occurs in normal mode and operation is restarted in normal mode after re-setting.



**Figure 9.124 Error Occurrence in Normal Mode, Recovery in Normal Mode**

1. After a reset, MTU2 output is low and ports are in the high-impedance state.
2. After a reset, the TMDR setting is for normal mode.
3. For channels 3 and 4, enable output with TOER before initializing the pins with TIOR.
4. Initialize the pins with TIOR. (The example shows initial high output, with low output on compare-match occurrence.)
5. Set MTU2 output with the PFC.
6. The count operation is started by TSTR.
7. Output goes low on compare-match occurrence.
8. An error occurs.
9. Set port output with the PFC and output the inverse of the active level.
10. The count operation is stopped by TSTR.
11. Not necessary when restarting in normal mode.
12. Initialize the pins with TIOR.
13. Set MTU2 output with the PFC.
14. Operation is restarted by TSTR.

**Operation when Error Occurs during Normal Mode Operation, and Operation is Restarted in PWM Mode 1:** Figure 9.125 shows an explanatory diagram of the case where an error occurs in normal mode and operation is restarted in PWM mode 1 after re-setting.

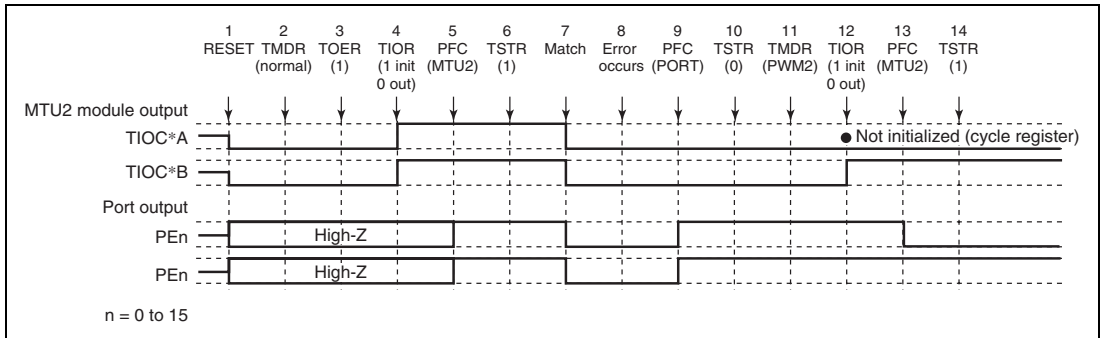


**Figure 9.125 Error Occurrence in Normal Mode, Recovery in PWM Mode 1**

1 to 10 are the same as in figure 9.124.

11. Set PWM mode 1.
12. Initialize the pins with TIOR. (In PWM mode 1, the TIOC\*B side is not initialized. If initialization is required, initialize in normal mode, then switch to PWM mode 1.)
13. Set MTU2 output with the PFC.
14. Operation is restarted by TSTR.

**Operation when Error Occurs during Normal Mode Operation, and Operation is Restarted in PWM Mode 2:** Figure 9.126 shows an explanatory diagram of the case where an error occurs in normal mode and operation is restarted in PWM mode 2 after re-setting.



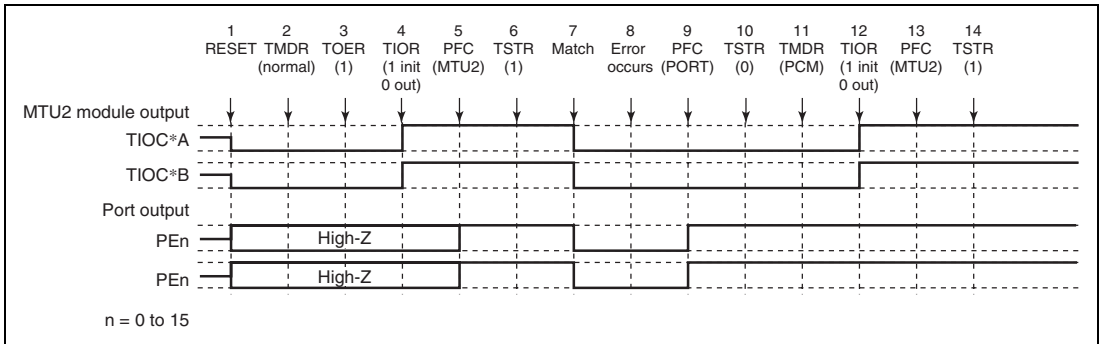
**Figure 9.126 Error Occurrence in Normal Mode, Recovery in PWM Mode 2**

1 to 10 are the same as in figure 9.124.

11. Set PWM mode 2.
12. Initialize the pins with TIOR. (In PWM mode 2, the cycle register pins are not initialized. If initialization is required, initialize in normal mode, then switch to PWM mode 2.)
13. Set MTU2 output with the PFC.
14. Operation is restarted by TSTR.

Note: PWM mode 2 can only be set for channels 0 to 2, and therefore TOER setting is not necessary.

**Operation when Error Occurs during Normal Mode Operation, and Operation is Restarted in Phase Counting Mode:** Figure 9.127 shows an explanatory diagram of the case where an error occurs in normal mode and operation is restarted in phase counting mode after re-setting.



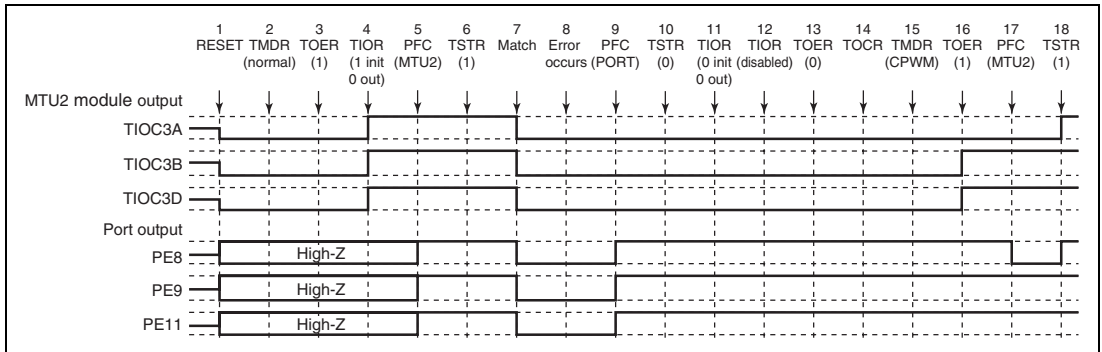
**Figure 9.127 Error Occurrence in Normal Mode, Recovery in Phase Counting Mode**

1 to 10 are the same as in figure 9.124.

11. Set phase counting mode.
12. Initialize the pins with TIOR.
13. Set MTU2 output with the PFC.
14. Operation is restarted by TSTR.

**Note:** Phase counting mode can only be set for channels 1 and 2, and therefore TOER setting is not necessary.

**Operation when Error Occurs during Normal Mode Operation, and Operation is Restarted in Complementary PWM Mode:** Figure 9.128 shows an explanatory diagram of the case where an error occurs in normal mode and operation is restarted in complementary PWM mode after re-setting.

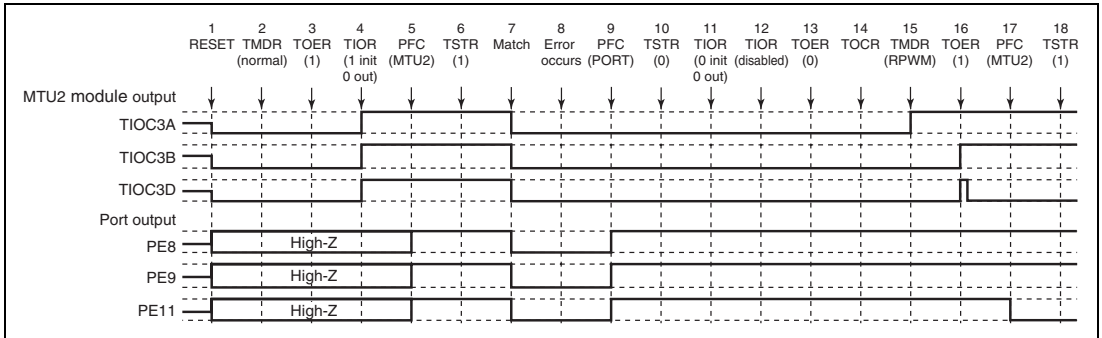


**Figure 9.128 Error Occurrence in Normal Mode, Recovery in Complementary PWM Mode**

1 to 10 are the same as in figure 9.124.

11. Initialize the normal mode waveform generation section with TIOR.
12. Disable operation of the normal mode waveform generation section with TIOR.
13. Disable channel 3 and 4 output with TOER.
14. Select the complementary PWM output level and cyclic output enabling/disabling with TOCR.
15. Set complementary PWM.
16. Enable channel 3 and 4 output with TOER.
17. Set MTU2 output with the PFC.
18. Operation is restarted by TSTR.

**Operation when Error Occurs during Normal Mode Operation, and Operation is Restarted in Reset-Synchronized PWM Mode:** Figure 9.129 shows an explanatory diagram of the case where an error occurs in normal mode and operation is restarted in reset-synchronized PWM mode after re-setting.



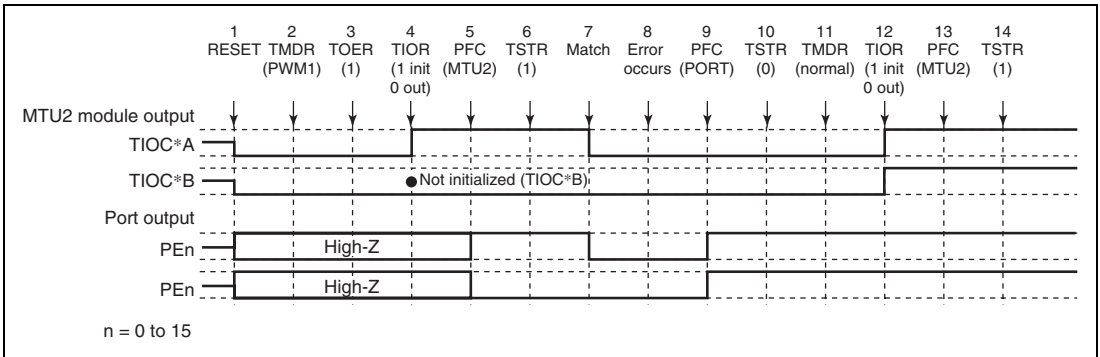
**Figure 9.129 Error Occurrence in Normal Mode, Recovery in Reset-Synchronized PWM Mode**

1 to 13 are the same as in figure 9.124.

14. Select the reset-synchronized PWM output level and cyclic output enabling/disabling with TOCR.
15. Set reset-synchronized PWM.
16. Enable channel 3 and 4 output with TOER.
17. Set MTU2 output with the PFC.
18. Operation is restarted by TSTR.



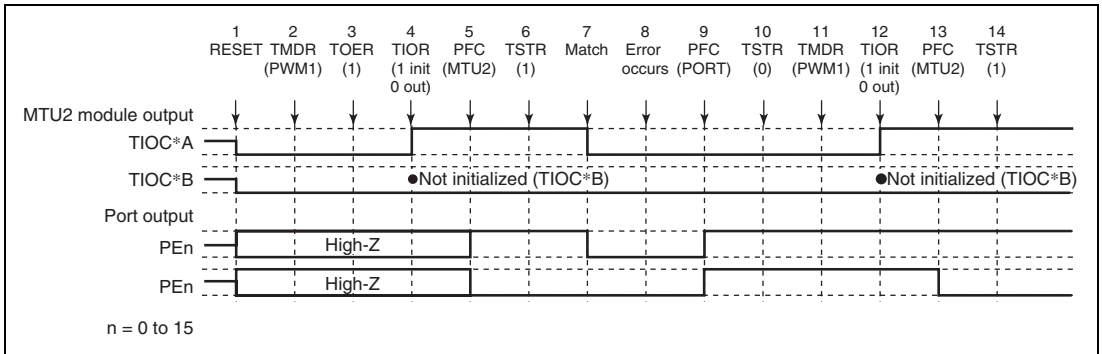
**Operation when Error Occurs during PWM Mode 1 Operation, and Operation is Restarted in Normal Mode:** Figure 9.130 shows an explanatory diagram of the case where an error occurs in PWM mode 1 and operation is restarted in normal mode after re-setting.



**Figure 9.130 Error Occurrence in PWM Mode 1, Recovery in Normal Mode**

1. After a reset, MTU2 output is low and ports are in the high-impedance state.
2. Set PWM mode 1.
3. For channels 3 and 4, enable output with TOER before initializing the pins with TIOR.
4. Initialize the pins with TIOR. (The example shows initial high output, with low output on compare-match occurrence. In PWM mode 1, the TIOC\*B side is not initialized.)
5. Set MTU2 output with the PFC.
6. The count operation is started by TSTR.
7. Output goes low on compare-match occurrence.
8. An error occurs.
9. Set port output with the PFC and output the inverse of the active level.
10. The count operation is stopped by TSTR.
11. Set normal mode.
12. Initialize the pins with TIOR.
13. Set MTU2 output with the PFC.
14. Operation is restarted by TSTR.

**Operation when Error Occurs during PWM Mode 1 Operation, and Operation is Restarted in PWM Mode 1:** Figure 9.131 shows an explanatory diagram of the case where an error occurs in PWM mode 1 and operation is restarted in PWM mode 1 after re-setting.

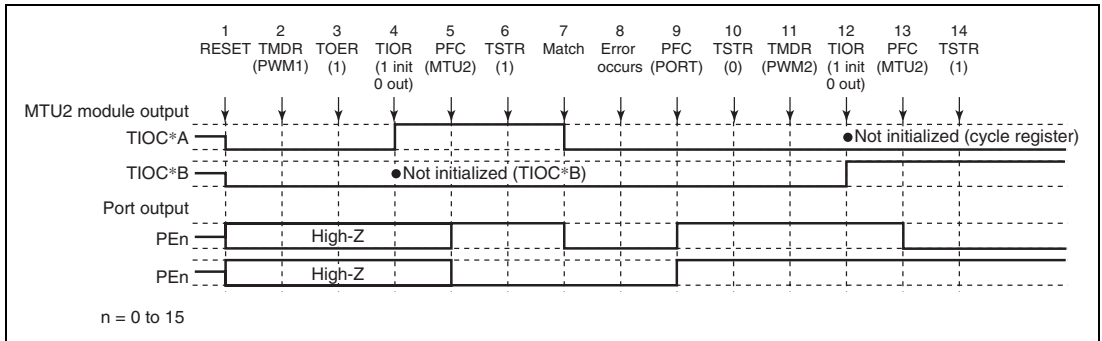


**Figure 9.131 Error Occurrence in PWM Mode 1, Recovery in PWM Mode 1**

1 to 10 are the same as in figure 9.130.

11. Not necessary when restarting in PWM mode 1.
12. Initialize the pins with TIOR. (In PWM mode 1, the TIOC\*B side is not initialized.)
13. Set MTU2 output with the PFC.
14. Operation is restarted by TSTR.

**Operation when Error Occurs during PWM Mode 1 Operation, and Operation is Restarted in PWM Mode 2:** Figure 9.132 shows an explanatory diagram of the case where an error occurs in PWM mode 1 and operation is restarted in PWM mode 2 after re-setting.



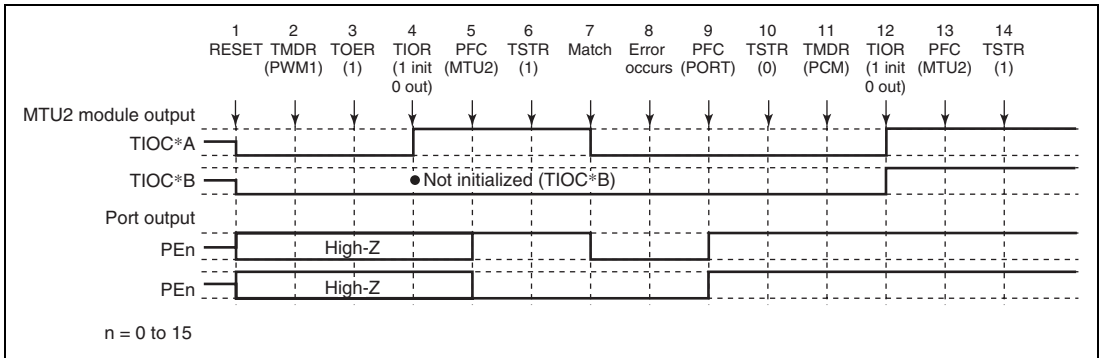
**Figure 9.132 Error Occurrence in PWM Mode 1, Recovery in PWM Mode 2**

1 to 10 are the same as in figure 9.130.

11. Set PWM mode 2.
12. Initialize the pins with TIOR. (In PWM mode 2, the cycle register pins are not initialized.)
13. Set MTU2 output with the PFC.
14. Operation is restarted by TSTR.

Note: PWM mode 2 can only be set for channels 0 to 2, and therefore TOER setting is not necessary.

**Operation when Error Occurs during PWM Mode 1 Operation, and Operation is Restarted in Phase Counting Mode:** Figure 9.133 shows an explanatory diagram of the case where an error occurs in PWM mode 1 and operation is restarted in phase counting mode after re-setting.



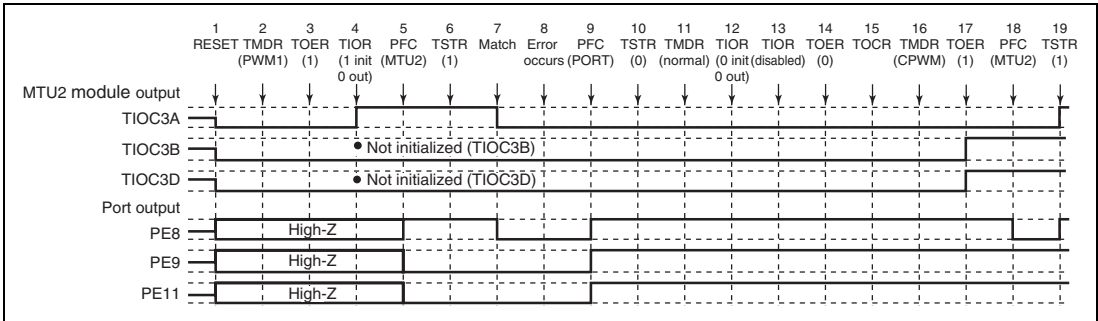
**Figure 9.133 Error Occurrence in PWM Mode 1, Recovery in Phase Counting Mode**

1 to 10 are the same as in figure 9.130.

11. Set phase counting mode.
12. Initialize the pins with TIOR.
13. Set MTU2 output with the PFC.
14. Operation is restarted by TSTR.

**Note:** Phase counting mode can only be set for channels 1 and 2, and therefore TOER setting is not necessary.

**Operation when Error Occurs during PWM Mode 1 Operation, and Operation is Restarted in Complementary PWM Mode:** Figure 9.134 shows an explanatory diagram of the case where an error occurs in PWM mode 1 and operation is restarted in complementary PWM mode after re-setting.

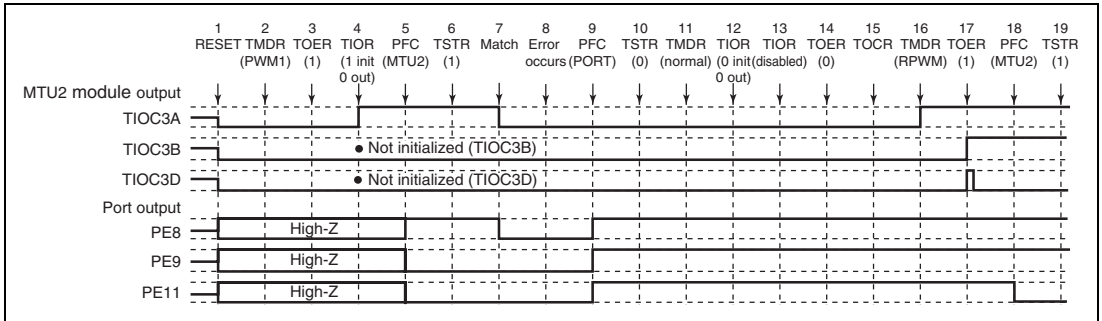


**Figure 9.134 Error Occurrence in PWM Mode 1, Recovery in Complementary PWM Mode**

1 to 10 are the same as in figure 9.130.

11. Set normal mode for initialization of the normal mode waveform generation section.
12. Initialize the PWM mode 1 waveform generation section with TIOR.
13. Disable operation of the PWM mode 1 waveform generation section with TIOR.
14. Disable channel 3 and 4 output with TOER.
15. Select the complementary PWM output level and cyclic output enabling/disabling with TOCR.
16. Set complementary PWM.
17. Enable channel 3 and 4 output with TOER.
18. Set MTU2 output with the PFC.
19. Operation is restarted by TSTR.

**Operation when Error Occurs during PWM Mode 1 Operation, and Operation is Restarted in Reset-Synchronized PWM Mode:** Figure 9.135 shows an explanatory diagram of the case where an error occurs in PWM mode 1 and operation is restarted in reset-synchronized PWM mode after re-setting.

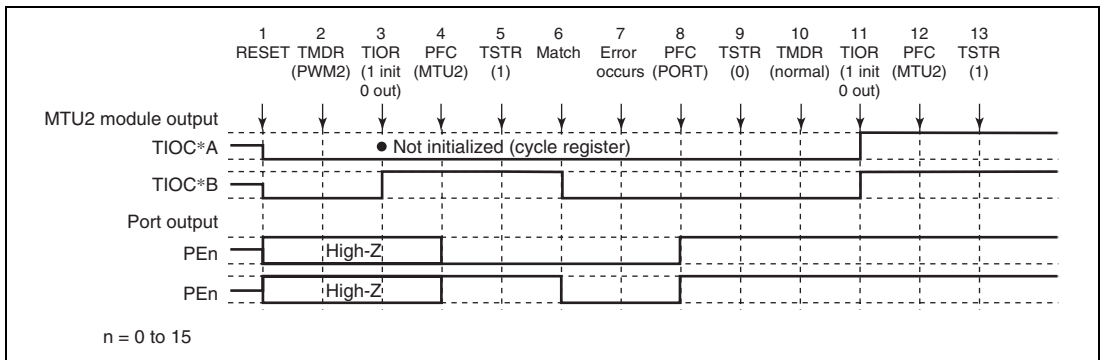


**Figure 9.135 Error Occurrence in PWM Mode 1, Recovery in Reset-Synchronized PWM Mode**

1 to 14 are the same as in figure 9.134.

15. Select the reset-synchronized PWM output level and cyclic output enabling/disabling with TOCR.
16. Set reset-synchronized PWM.
17. Enable channel 3 and 4 output with TOER.
18. Set MTU2 output with the PFC.
19. Operation is restarted by TSTR.

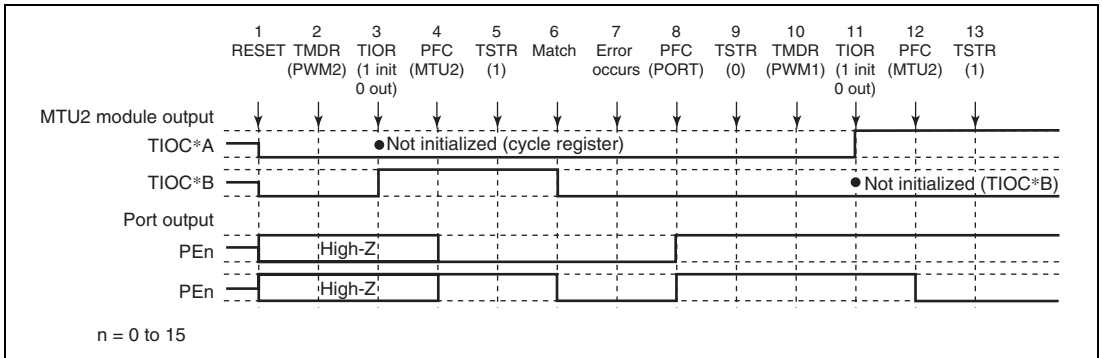
**Operation when Error Occurs during PWM Mode 2 Operation, and Operation is Restarted in Normal Mode:** Figure 9.136 shows an explanatory diagram of the case where an error occurs in PWM mode 2 and operation is restarted in normal mode after re-setting.



**Figure 9.136 Error Occurrence in PWM Mode 2, Recovery in Normal Mode**

1. After a reset, MTU2 output is low and ports are in the high-impedance state.
2. Set PWM mode 2.
3. Initialize the pins with TIOR. (The example shows initial high output, with low output on compare-match occurrence. In PWM mode 2, the cycle register pins are not initialized. In the example, TIOC \*A is the cycle register.)
4. Set MTU2 output with the PFC.
5. The count operation is started by TSTR.
6. Output goes low on compare-match occurrence.
7. An error occurs.
8. Set port output with the PFC and output the inverse of the active level.
9. The count operation is stopped by TSTR.
10. Set normal mode.
11. Initialize the pins with TIOR.
12. Set MTU2 output with the PFC.
13. Operation is restarted by TSTR.

**Operation when Error Occurs during PWM Mode 2 Operation, and Operation is Restarted in PWM Mode 1:** Figure 9.137 shows an explanatory diagram of the case where an error occurs in PWM mode 2 and operation is restarted in PWM mode 1 after re-setting.



**Figure 9.137 Error Occurrence in PWM Mode 2, Recovery in PWM Mode 1**

1 to 9 are the same as in figure 9.136.

10. Set PWM mode 1.

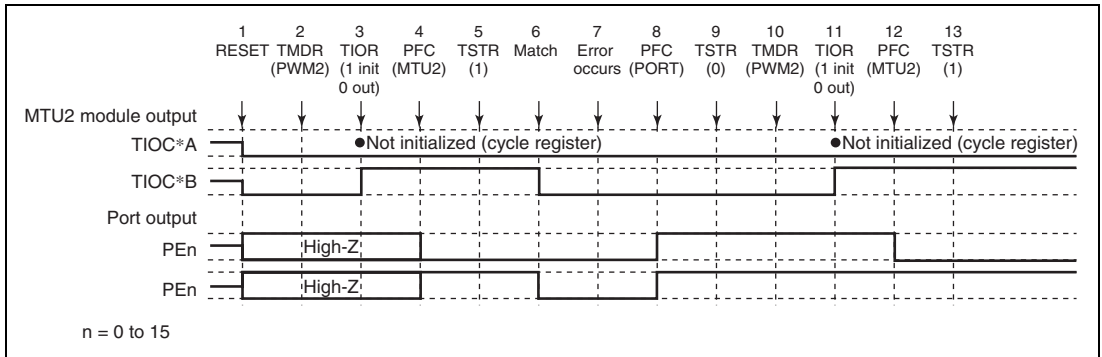
11. Initialize the pins with TIOR. (In PWM mode 1, the TIOC\*B side is not initialized.)

12. Set MTU2 output with the PFC.

13. Operation is restarted by TSTR.



**Operation when Error Occurs during PWM Mode 2 Operation, and Operation is Restarted in PWM Mode 2:** Figure 9.138 shows an explanatory diagram of the case where an error occurs in PWM mode 2 and operation is restarted in PWM mode 2 after re-setting.



**Figure 9.138 Error Occurrence in PWM Mode 2, Recovery in PWM Mode 2**

1 to 9 are the same as in figure 9.136.

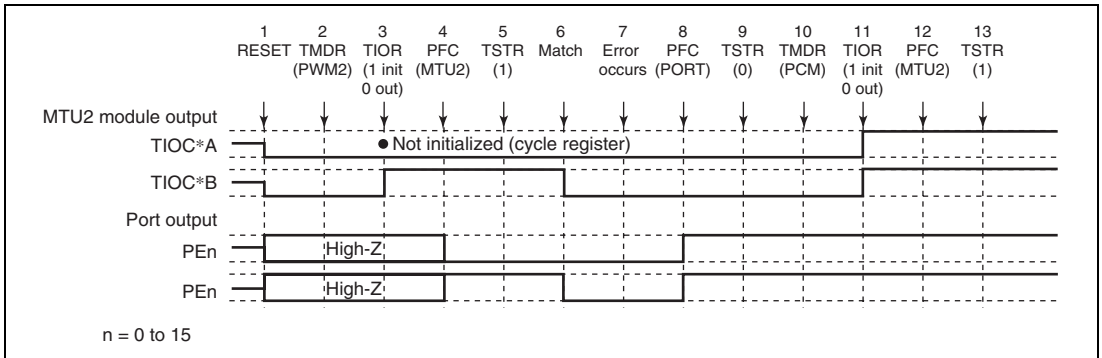
10. Not necessary when restarting in PWM mode 2.

11. Initialize the pins with TIOR. (In PWM mode 2, the cycle register pins are not initialized.)

12. Set MTU2 output with the PFC.

13. Operation is restarted by TSTR.

**Operation when Error Occurs during PWM Mode 2 Operation, and Operation is Restarted in Phase Counting Mode:** Figure 9.139 shows an explanatory diagram of the case where an error occurs in PWM mode 2 and operation is restarted in phase counting mode after re-setting.

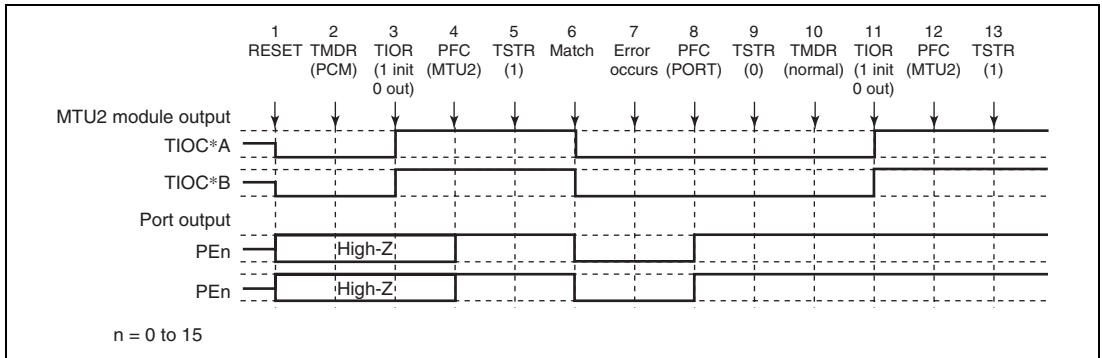


**Figure 9.139 Error Occurrence in PWM Mode 2, Recovery in Phase Counting Mode**

1 to 9 are the same as in figure 9.136.

10. Set phase counting mode.
11. Initialize the pins with TIOR.
12. Set MTU2 output with the PFC.
13. Operation is restarted by TSTR.

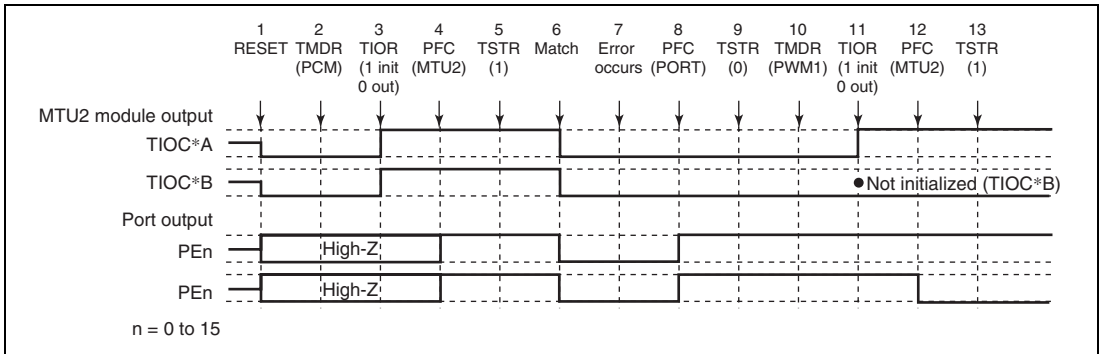
**Operation when Error Occurs during Phase Counting Mode Operation, and Operation is Restarted in Normal Mode:** Figure 9.140 shows an explanatory diagram of the case where an error occurs in phase counting mode and operation is restarted in normal mode after re-setting.



**Figure 9.140 Error Occurrence in Phase Counting Mode, Recovery in Normal Mode**

1. After a reset, MTU2 output is low and ports are in the high-impedance state.
2. Set phase counting mode.
3. Initialize the pins with TIOR. (The example shows initial high output, with low output on compare-match occurrence.)
4. Set MTU2 output with the PFC.
5. The count operation is started by TSTR.
6. Output goes low on compare-match occurrence.
7. An error occurs.
8. Set port output with the PFC and output the inverse of the active level.
9. The count operation is stopped by TSTR.
10. Set in normal mode.
11. Initialize the pins with TIOR.
12. Set MTU2 output with the PFC.
13. Operation is restarted by TSTR.

**Operation when Error Occurs during Phase Counting Mode Operation, and Operation is Restarted in PWM Mode 1:** Figure 9.141 shows an explanatory diagram of the case where an error occurs in phase counting mode and operation is restarted in PWM mode 1 after re-setting.

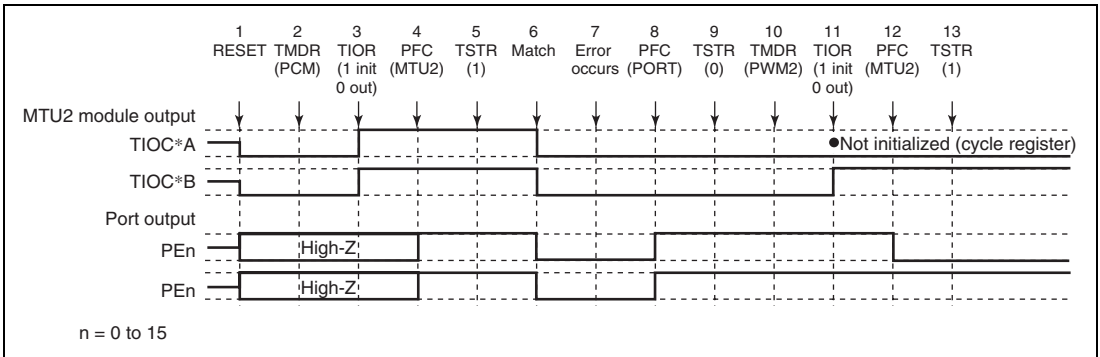


**Figure 9.141 Error Occurrence in Phase Counting Mode, Recovery in PWM Mode 1**

1 to 9 are the same as in figure 9.140.

10. Set PWM mode 1.
11. Initialize the pins with TIOR. (In PWM mode 1, the TIOC \*B side is not initialized.)
12. Set MTU2 output with the PFC.
13. Operation is restarted by TSTR.

**Operation when Error Occurs during Phase Counting Mode Operation, and Operation is Restarted in PWM Mode 2:** Figure 9.142 shows an explanatory diagram of the case where an error occurs in phase counting mode and operation is restarted in PWM mode 2 after re-setting.

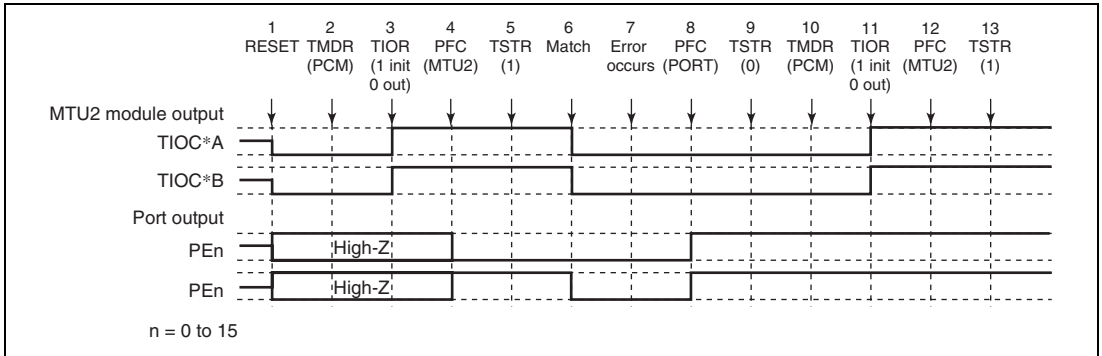


**Figure 9.142 Error Occurrence in Phase Counting Mode, Recovery in PWM Mode 2**

1 to 9 are the same as in figure 9.140.

10. Set PWM mode 2.
11. Initialize the pins with TIOR. (In PWM mode 2, the cycle register pins are not initialized.)
12. Set MTU2 output with the PFC.
13. Operation is restarted by TSTR.

**Operation when Error Occurs during Phase Counting Mode Operation, and Operation is Restarted in Phase Counting Mode:** Figure 9.143 shows an explanatory diagram of the case where an error occurs in phase counting mode and operation is restarted in phase counting mode after re-setting.



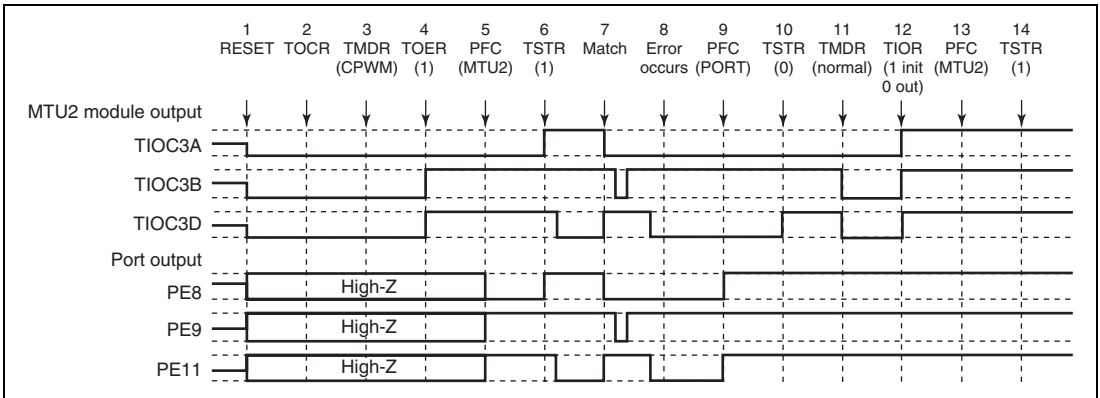
**Figure 9.143 Error Occurrence in Phase Counting Mode, Recovery in Phase Counting Mode**

1 to 9 are the same as in figure 9.140.

10. Not necessary when restarting in phase counting mode.
11. Initialize the pins with TIOR.
12. Set MTU2 output with the PFC.
13. Operation is restarted by TSTR.

**Operation when Error Occurs during Complementary PWM Mode Operation, and**

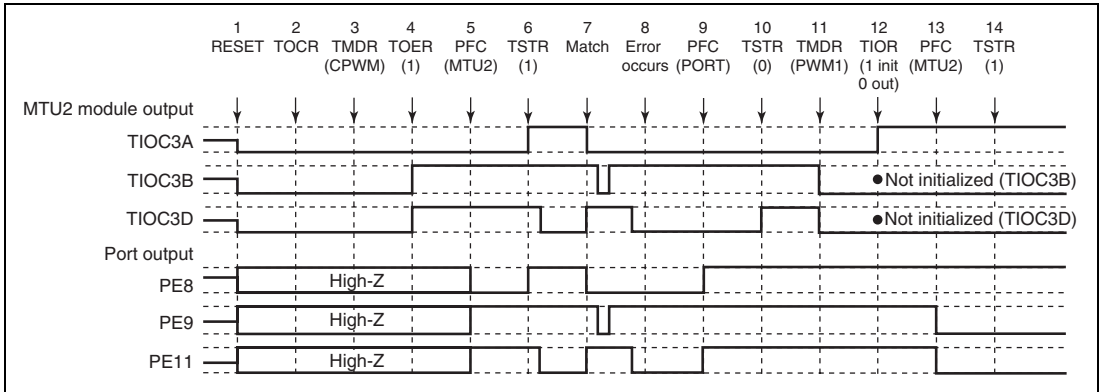
**Operation is Restarted in Normal Mode:** Figure 9.144 shows an explanatory diagram of the case where an error occurs in complementary PWM mode and operation is restarted in normal mode after re-setting.



**Figure 9.144 Error Occurrence in Complementary PWM Mode, Recovery in Normal Mode**

1. After a reset, MTU2 output is low and ports are in the high-impedance state.
2. Select the complementary PWM output level and cyclic output enabling/disabling with TOCR.
3. Set complementary PWM.
4. Enable channel 3 and 4 output with TOER.
5. Set MTU2 output with the PFC.
6. The count operation is started by TSTR.
7. The complementary PWM waveform is output on compare-match occurrence.
8. An error occurs.
9. Set port output with the PFC and output the inverse of the active level.
10. The count operation is stopped by TSTR. (MTU2 output becomes the complementary PWM output initial value.)
11. Set normal mode. (MTU2 output goes low.)
12. Initialize the pins with TIOR.
13. Set MTU2 output with the PFC.
14. Operation is restarted by TSTR.

**Operation when Error Occurs during Complementary PWM Mode Operation, and Operation is Restarted in PWM Mode 1:** Figure 9.145 shows an explanatory diagram of the case where an error occurs in complementary PWM mode and operation is restarted in PWM mode 1 after re-setting.



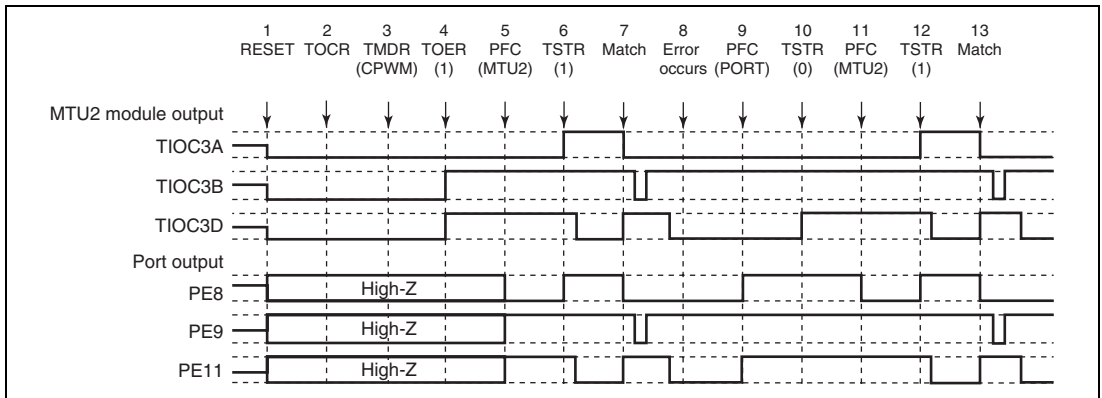
**Figure 9.145 Error Occurrence in Complementary PWM Mode, Recovery in PWM Mode 1**

1 to 10 are the same as in figure 9.144.

11. Set PWM mode 1. (MTU2 output goes low.)
12. Initialize the pins with TIOR. (In PWM mode 1, the TIOC \*B side is not initialized.)
13. Set MTU2 output with the PFC.
14. Operation is restarted by TSTR.



**Operation when Error Occurs during Complementary PWM Mode Operation, and Operation is Restarted in Complementary PWM Mode:** Figure 9.146 shows an explanatory diagram of the case where an error occurs in complementary PWM mode and operation is restarted in complementary PWM mode after re-setting (when operation is restarted using the cycle and duty settings at the time the counter was stopped).

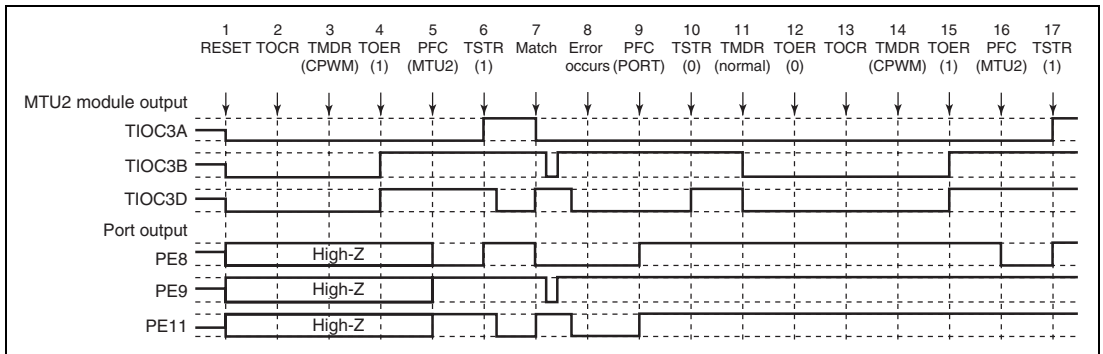


**Figure 9.146 Error Occurrence in Complementary PWM Mode, Recovery in Complementary PWM Mode**

1 to 10 are the same as in figure 9.144.

11. Set MTU2 output with the PFC.
12. Operation is restarted by TSTR.
13. The complementary PWM waveform is output on compare-match occurrence.

**Operation when Error Occurs during Complementary PWM Mode Operation, and Operation is Restarted in Complementary PWM Mode:** Figure 9.147 shows an explanatory diagram of the case where an error occurs in complementary PWM mode and operation is restarted in complementary PWM mode after re-setting (when operation is restarted using completely new cycle and duty settings).

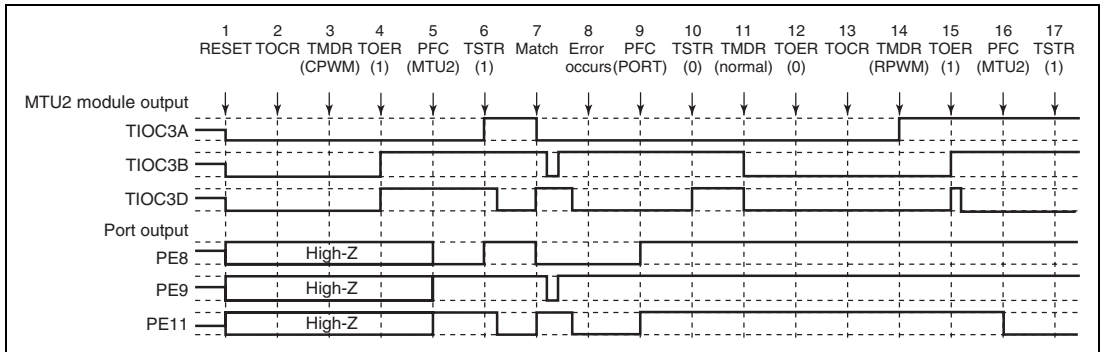


**Figure 9.147 Error Occurrence in Complementary PWM Mode, Recovery in Complementary PWM Mode**

1 to 10 are the same as in figure 9.144.

11. Set normal mode and make new settings. (MTU2 output goes low.)
12. Disable channel 3 and 4 output with TOER.
13. Select the complementary PWM mode output level and cyclic output enabling/disabling with TOCR.
14. Set complementary PWM.
15. Enable channel 3 and 4 output with TOER.
16. Set MTU2 output with the PFC.
17. Operation is restarted by TSTR.

**Operation when Error Occurs during Complementary PWM Mode Operation, and Operation is Restarted in Reset-Synchronized PWM Mode:** Figure 9.148 shows an explanatory diagram of the case where an error occurs in complementary PWM mode and operation is restarted in reset-synchronized PWM mode after re-setting.

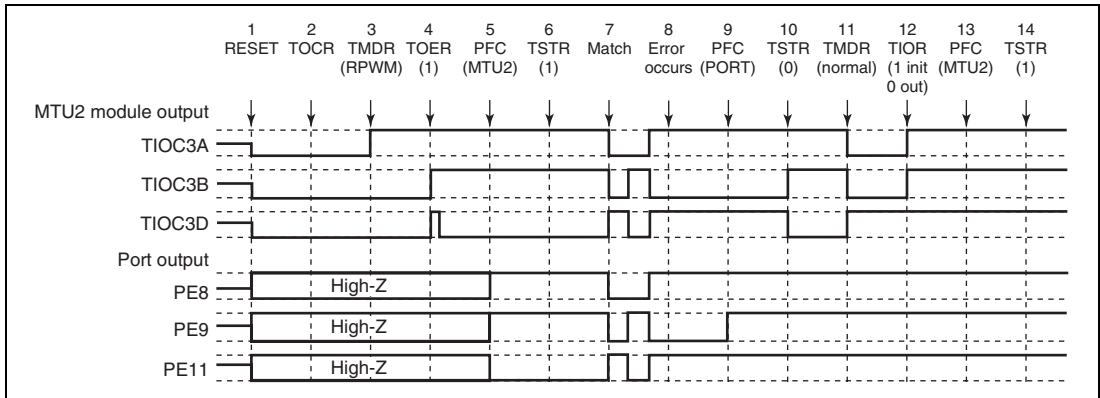


**Figure 9.148 Error Occurrence in Complementary PWM Mode, Recovery in Reset-Synchronized PWM Mode**

1 to 10 are the same as in figure 9.144.

11. Set normal mode. (MTU2 output goes low.)
12. Disable channel 3 and 4 output with TOER.
13. Select the reset-synchronized PWM mode output level and cyclic output enabling/disabling with TOCR.
14. Set reset-synchronized PWM.
15. Enable channel 3 and 4 output with TOER.
16. Set MTU2 output with the PFC.
17. Operation is restarted by TSTR.

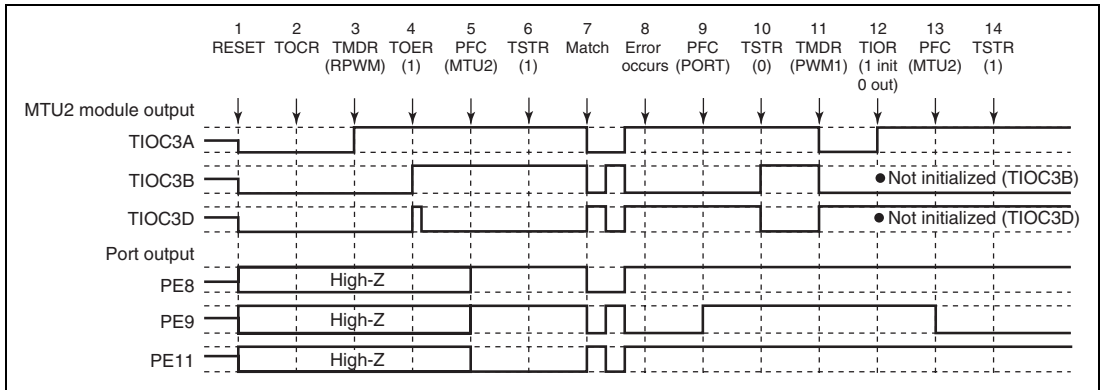
**Operation when Error Occurs during Reset-Synchronized PWM Mode Operation, and Operation is Restarted in Normal Mode:** Figure 9.149 shows an explanatory diagram of the case where an error occurs in reset-synchronized PWM mode and operation is restarted in normal mode after re-setting.



**Figure 9.149 Error Occurrence in Reset-Synchronized PWM Mode, Recovery in Normal Mode**

1. After a reset, MTU2 output is low and ports are in the high-impedance state.
2. Select the reset-synchronized PWM output level and cyclic output enabling/disabling with TOCR.
3. Set reset-synchronized PWM.
4. Enable channel 3 and 4 output with TOER.
5. Set MTU2 output with the PFC.
6. The count operation is started by TSTR.
7. The reset-synchronized PWM waveform is output on compare-match occurrence.
8. An error occurs.
9. Set port output with the PFC and output the inverse of the active level.
10. The count operation is stopped by TSTR. (MTU2 output becomes the reset-synchronized PWM output initial value.)
11. Set normal mode. (MTU2 positive phase output is low, and negative phase output is high.)
12. Initialize the pins with TIOR.
13. Set MTU2 output with the PFC.
14. Operation is restarted by TSTR.

**Operation when Error Occurs during Reset-Synchronized PWM Mode Operation, and Operation is Restarted in PWM Mode 1:** Figure 9.150 shows an explanatory diagram of the case where an error occurs in reset-synchronized PWM mode and operation is restarted in PWM mode 1 after re-setting.

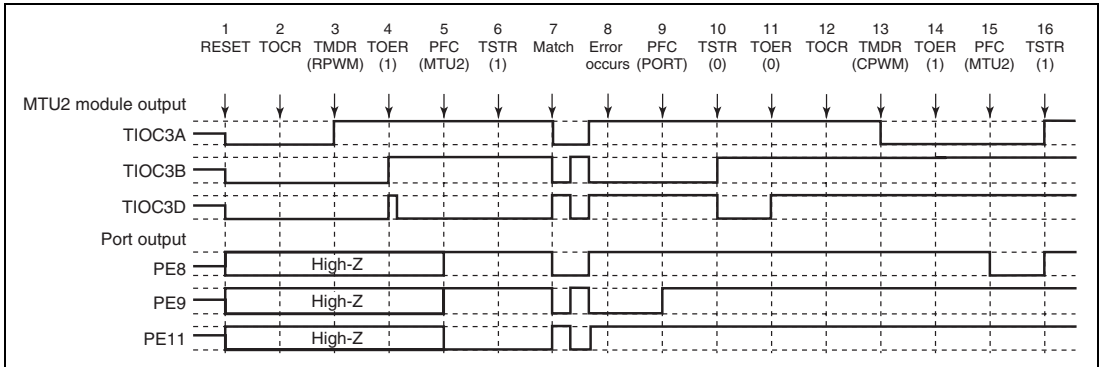


**Figure 9.150 Error Occurrence in Reset-Synchronized PWM Mode, Recovery in PWM Mode 1**

1 to 10 are the same as in figure 9.149.

11. Set PWM mode 1. (MTU2 positive phase output is low, and negative phase output is high.)
12. Initialize the pins with TIOR. (In PWM mode 1, the TIOC \*B side is not initialized.)
13. Set MTU2 output with the PFC.
14. Operation is restarted by TSTR.

**Operation when Error Occurs during Reset-Synchronized PWM Mode Operation, and Operation is Restarted in Complementary PWM Mode:** Figure 9.151 shows an explanatory diagram of the case where an error occurs in reset-synchronized PWM mode and operation is restarted in complementary PWM mode after re-setting.

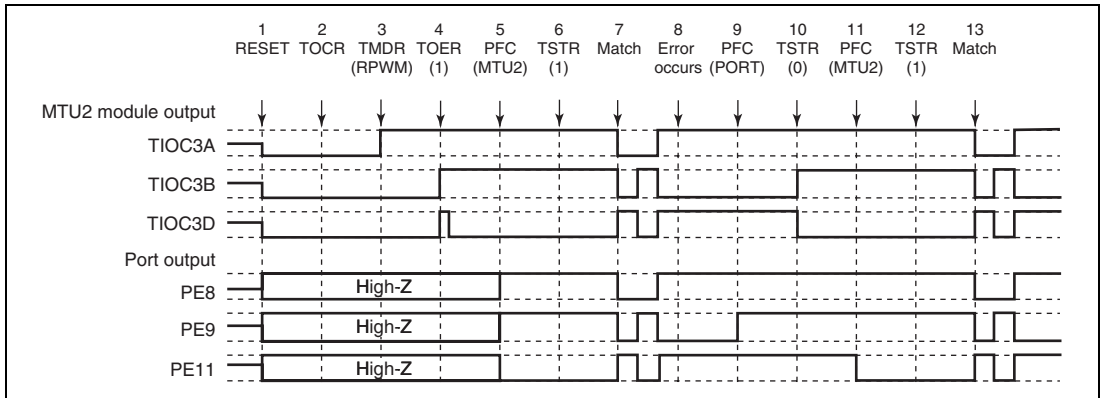


**Figure 9.151 Error Occurrence in Reset-Synchronized PWM Mode, Recovery in Complementary PWM Mode**

1 to 10 are the same as in figure 9.149.

11. Disable channel 3 and 4 output with TOER.
12. Select the complementary PWM output level and cyclic output enabling/disabling with TOCR.
13. Set complementary PWM. (The MTU2 cyclic output pin goes low.)
14. Enable channel 3 and 4 output with TOER.
15. Set MTU2 output with the PFC.
16. Operation is restarted by TSTR.

**Operation when Error Occurs during Reset-Synchronized PWM Mode Operation, and Operation is Restarted in Reset-Synchronized PWM Mode:** Figure 9.152 shows an explanatory diagram of the case where an error occurs in reset-synchronized PWM mode and operation is restarted in reset-synchronized PWM mode after re-setting.



**Figure 9.152 Error Occurrence in Reset-Synchronized PWM Mode, Recovery in Reset-Synchronized PWM Mode**

1 to 10 are the same as in figure 9.149.

11. Set MTU2 output with the PFC.
12. Operation is restarted by TSTR.
13. The reset-synchronized PWM waveform is output on compare-match occurrence.





## Section 10 Port Output Enable (POE)

The port output enable (POE) can be used to place the high-current pins (pins multiplexed with TIOC3B, TIOC3D, TIOC4A, TIOC4B, TIOC4C, and TIOC4D in the MTU2) and the pins for channel 0 of the MTU2 (pins multiplexed with TIOC0A, TIOC0B, TIOC0C, and TIOC0D) in high-impedance state, depending on the change on  $\overline{\text{POE0}}$ ,  $\overline{\text{POE1}}$ ,  $\overline{\text{POE3}}^*$ , and  $\overline{\text{POE8}}$  input pins and the output status of the high-current pins, or by modifying register settings. It can also simultaneously generate interrupt requests.

### 10.1 Features

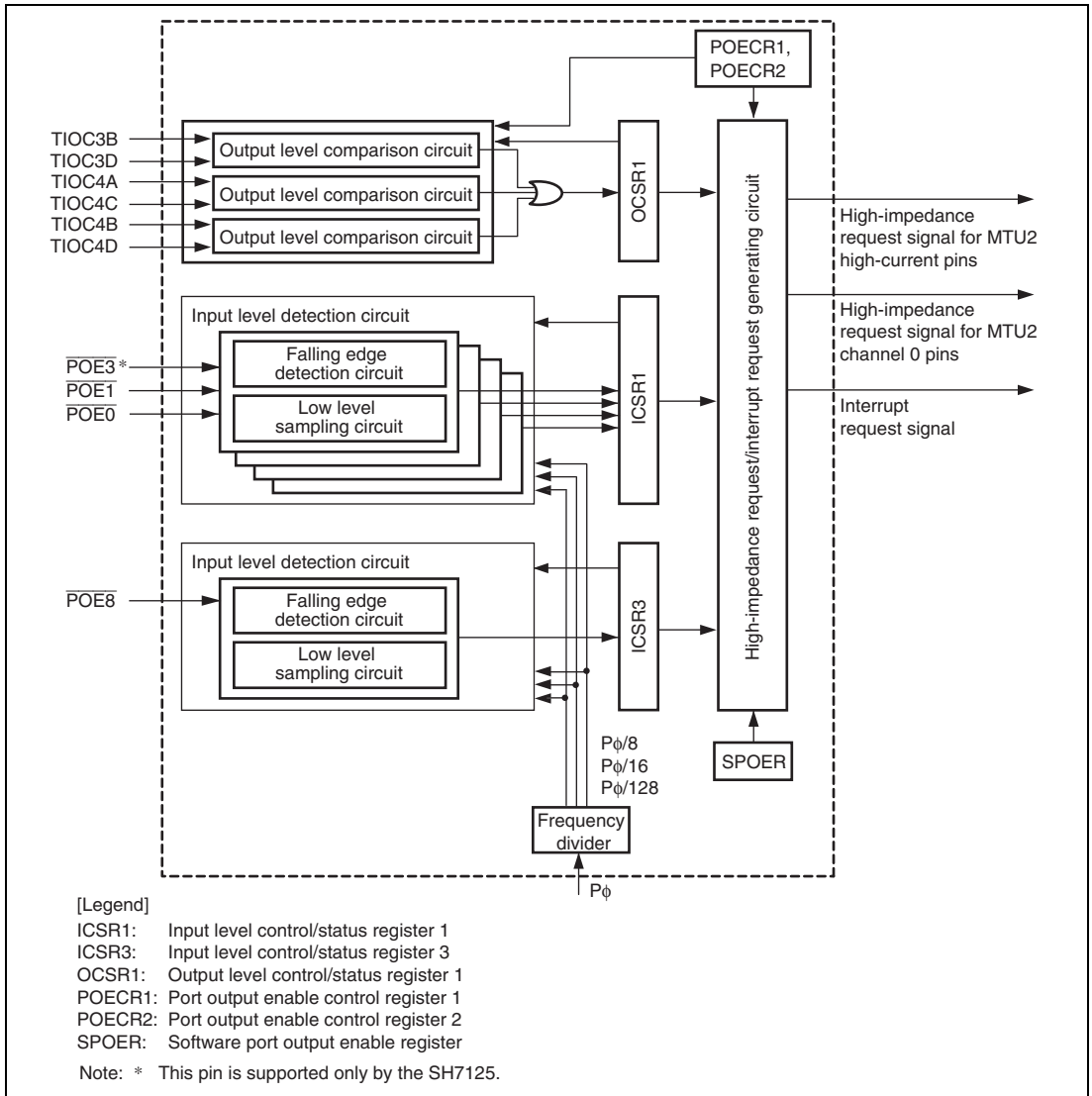
- Each of the  $\overline{\text{POE0}}$ ,  $\overline{\text{POE1}}$ ,  $\overline{\text{POE3}}^*$ , and  $\overline{\text{POE8}}$  input pins can be set for falling edge,  $P\phi/8 \times 16$ ,  $P\phi/16 \times 16$ , or  $P\phi/128 \times 16$  low-level sampling.
- High-current pins and the pins for channel 0 of the MTU2 can be placed in high-impedance state by  $\overline{\text{POE0}}$ ,  $\overline{\text{POE1}}$ ,  $\overline{\text{POE3}}^*$ , and  $\overline{\text{POE8}}$  pin falling-edge or low-level sampling.
- High-current pins can be placed in high-impedance state when the high-current pin output levels are compared and simultaneous active-level output continues for one cycle or more.
- High-current pins and the pins for channel 0 of the MTU2 can be placed in high-impedance state by modifying the POE register settings.
- Interrupts can be generated by input-level sampling or output-level comparison results.

The POE has input level detection circuits, output level comparison circuits, and a high-impedance request/interrupt request generating circuit as shown in figure 10.1, Block Diagram of POE.

In addition to control by the POE, high-current pins can be placed in high-impedance state when the oscillator stops or in software standby state. For details, refer to appendix A, Pin States.

Note: \* The  $\overline{\text{POE3}}$  pin is supported only by the SH7125.

Figure 10.1 shows a block diagram of the POE.



**Figure 10.1 Block Diagram of POE**

## 10.2 Input/Output Pins

**Table 10.1 Pin Configuration**

Name	Abbreviation	I/O	Description
Port output enable input pins 0, 1, 3	$\overline{POE0}$ , $\overline{POE1}$ , $\overline{POE3}$ *	Input	Input request signals to place high-current pins for MTU2 in high-impedance state*
Port output enable input pin 8	$\overline{POE8}$	Input	Inputs a request signal to place pins for channel 0 in MTU2 in high-impedance state*

Note: \* When the  $\overline{POE3}$  function is selected in the PFC, the pin is pulled up inside the LSI if nothing is input to it. The  $\overline{POE3}$  pin is supported only by the SH7125.

Table 10.2 shows output-level comparisons with pin combinations.

**Table 10.2 Pin Combinations**

Pin Combination	I/O	Description
PE9/TIOC3B and PE11/TIOC3D PE12/TIOC4A and PE14/TIOC4C PE13/TIOC4B and PE15/TIOC4D	Output	<p>The high-current pins for the MTU2 are placed in high-impedance state when the pins simultaneously output an active level (low level when the output level select P (OLSP) bit of the timer output control register (TOCR) in the MTU2 is 0 or high level when the bit is 1) for one or more cycles of the peripheral clock (<math>P\phi</math>).</p> <p>This active level comparison is done when the MTU2 output function or general output function is selected in the pin function controller. If another function is selected, the output level is not checked.</p> <p>Pin combinations for output comparison and high-impedance control can be selected by POE registers.</p>

### 10.3 Register Descriptions

The POE has the following registers. For details on register addresses and register states during each processing, refer to section 20, List of Registers.

**Table 10.3 Register Configuration**

Register Name	Abbreviation	R/W	Initial Value	Address	Access Size
Input level control/status register 1	ICSR1	R/W	H'0000	H'FFFFD000	8, 16, 32
Output level control/status register 1	OCSR1	R/W	H'0000	H'FFFFD002	8, 16
Input level control/status register 3	ICSR3	R/W	H'0000	H'FFFFD008	8, 16, 32
Software port output enable register	SPOER	R/W	H'00	H'FFFFD00A	8
Port output enable control register 1	POECR1	R/W	H'00	H'FFFFD00B	8
Port output enable control register 2	POECR2	R/W	H'7700	H'FFFFD00C	8, 16

### 10.3.1 Input Level Control/Status Register 1 (ICSR1)

ICSR1 is a 16-bit readable/writable register that selects the  $\overline{\text{POE0}}$ ,  $\overline{\text{POE1}}$ , and  $\overline{\text{POE3}}$  pin input modes, controls the enable/disable of interrupts, and indicates status.

Bit:	15	14	13	12	11	10	9	8	7	6	5	4	3	2	1	0
	POE3F	-	POE1F	POE0F	-	-	-	PIE1	POE3M[1:0]	-	-	POE1M[1:0]	POE0M[1:0]			
Initial value:	0	0	0	0	0	0	0	0	0	0	0	0	0	0	0	0
	R/W	R/(W)*1	R/(W)*1	R/(W)*1	R/(W)*1	R	R	R	R/W	R/W*2	R/W*2	R/W*2	R/W*2	R/W*2	R/W*2	R/W*2

- Notes: 1. Writing 0 to this bit after reading it as 1 clears the flag and is the only allowed way.  
 2. Can be modified only once after a power-on reset.

Bit	Bit Name	Initial value	R/W	Description
15	POE3F	0	R/(W)*1	<p>POE3 Flag</p> <p>(Supported only by the SH7125.)</p> <p>This flag indicates that a high impedance request has been input to the <math>\overline{\text{POE3}}</math> pin.</p> <p>[Clearing conditions]</p> <ul style="list-style-type: none"> <li>By writing 0 to POE3F after reading POE3F = 1 (when the falling edge is selected by bits 7 and 6 in ICSR1)</li> <li>By writing 0 to POE3F after reading POE3F = 1 after a high level input to POE3 is sampled at <math>P\phi/8</math>, <math>P\phi/16</math>, or <math>P\phi/128</math> clock (when low-level sampling is selected by bits 7 and 6 in ICSR1)</li> </ul> <p>[Setting condition]</p> <ul style="list-style-type: none"> <li>When the input set by ICSR1 bits 7 and 6 occurs at the <math>\overline{\text{POE3}}</math> pin</li> </ul>
14	—	0	R/(W)*1	<p>Reserved</p> <p>This bit is always read as 0. The write value should always be 0.</p>

Bit	Bit Name	Initial value	R/W	Description
13	POE1F	0	R/(W)* <sup>1</sup>	<p>POE1 Flag</p> <p>This flag indicates that a high impedance request has been input to the <math>\overline{\text{POE1}}</math> pin.</p> <p>[Clearing conditions]</p> <ul style="list-style-type: none"> <li>By writing 0 to POE1F after reading POE1F = 1 (when the falling edge is selected by bits 3 and 2 in ICSR1)</li> <li>By writing 0 to POE1F after reading POE1F = 1 after a high level input to POE1 is sampled at <math>P\phi/8</math>, <math>P\phi/16</math>, or <math>P\phi/128</math> clock (when low-level sampling is selected by bits 3 and 2 in ICSR1)</li> </ul> <p>[Setting condition]</p> <ul style="list-style-type: none"> <li>When the input set by ICSR1 bits 3 and 2 occurs at the <math>\overline{\text{POE1}}</math> pin</li> </ul>
12	POE0F	0	R/(W)* <sup>1</sup>	<p>POE0 Flag</p> <p>This flag indicates that a high impedance request has been input to the <math>\overline{\text{POE0}}</math> pin.</p> <p>[Clearing conditions]</p> <ul style="list-style-type: none"> <li>By writing 0 to POE0F after reading POE0F = 1 (when the falling edge is selected by bits 1 and 0 in ICSR1)</li> <li>By writing 0 to POE0F after reading POE0F = 1 after a high level input to POE0 is sampled at <math>P\phi/8</math>, <math>P\phi/16</math>, or <math>P\phi/128</math> clock (when low-level sampling is selected by bits 1 and 0 in ICSR1)</li> </ul> <p>[Setting condition]</p> <ul style="list-style-type: none"> <li>When the input set by ICSR1 bits 1 and 0 occurs at the <math>\overline{\text{POE0}}</math> pin</li> </ul>
11 to 9	—	All 0	R	<p>Reserved</p> <p>These bits are always read as 0. The write value should always be 0.</p>

Bit	Bit Name	Initial value	R/W	Description
8	PIE1	0	R/W	<p>Port Interrupt Enable 1</p> <p>This bit enables/disables interrupt requests when any one of the POE0F to POE3F bits of the ICSR1 is set to 1.</p> <p>0: Interrupt requests disabled</p> <p>1: Interrupt requests enabled</p>
7, 6	POE3M[1:0]	00	R/W* <sup>2</sup>	<p>POE3 mode 1, 0</p> <p>(Supported only by the SH7125. Write 00 to these bits in the SH7124.)</p> <p>These bits select the input mode of the <math>\overline{POE3}</math> pin.</p> <p>00: Accept request on falling edge of POE3 input</p> <p>01: Accept request when POE3 input has been sampled for 16 P<math>\phi</math>/8 clock pulses and all are low level.</p> <p>10: Accept request when POE3 input has been sampled for 16 P<math>\phi</math>/16 clock pulses and all are low level.</p> <p>11: Accept request when POE3 input has been sampled for 16 P<math>\phi</math>/128 clock pulses and all are low level.</p>
5, 4	—	All 0	R/W* <sup>2</sup>	<p>Reserved</p> <p>These bits are always read as 0. The write value should always be 0.</p>
3, 2	POE1M[1:0]	00	R/W* <sup>2</sup>	<p>POE1 mode 1, 0</p> <p>These bits select the input mode of the <math>\overline{POE1}</math> pin.</p> <p>00: Accept request on falling edge of POE1 input</p> <p>01: Accept request when POE1 input has been sampled for 16 P<math>\phi</math>/8 clock pulses and all are low level.</p> <p>10: Accept request when POE1 input has been sampled for 16 P<math>\phi</math>/16 clock pulses and all are low level.</p> <p>11: Accept request when POE1 input has been sampled for 16 P<math>\phi</math>/128 clock pulses and all are low level.</p>

Bit	Bit Name	Initial value	R/W	Description
1, 0	POE0M[1:0]	00	R/W*2	<p>POE0 mode 1, 0</p> <p>These bits select the input mode of the <math>\overline{\text{POE0}}</math> pin.</p> <p>00: Accept request on falling edge of POE0 input</p> <p>01: Accept request when POE0 input has been sampled for 16 P<math>\phi</math>/8 clock pulses and all are low level.</p> <p>10: Accept request when POE0 input has been sampled for 16 P<math>\phi</math>/16 clock pulses and all are low level.</p> <p>11: Accept request when POE0 input has been sampled for 16 P<math>\phi</math>/128 clock pulses and all are low level.</p>

Notes: 1. Writing 0 to this bit after reading it as 1 clears the flag and is the only allowed way.  
 2. Can be modified only once after a power-on reset.

### 10.3.2 Output Level Control/Status Register 1 (OCSR1)

OCSR1 is a 16-bit readable/writable register that controls the enable/disable of both output level comparison and interrupts, and indicates status.

Bit:	15	14	13	12	11	10	9	8	7	6	5	4	3	2	1	0
	OSF1	-	-	-	-	-	OCE1	OIE1	-	-	-	-	-	-	-	-
Initial value:	0	0	0	0	0	0	0	0	0	0	0	0	0	0	0	0
R/W:R/(W)*1	R	R	R	R	R	R	R/W*2	R/W	R	R	R	R	R	R	R	R

Notes: 1. Writing 0 to this bit after reading it as 1 clears the flag and is the only allowed way.  
 2. Can be modified only once after a power-on reset.

Bit	Bit Name	Initial value	R/W	Description
15	OSF1	0	R/(W)*1	<p>Output Short Flag 1</p> <p>This flag indicates that any one of the three pairs of MTU2 2-phase outputs to be compared has simultaneously become an active level.</p> <p>[Clearing condition]</p> <ul style="list-style-type: none"> <li>By writing 0 to OSF1 after reading OSF1 = 1</li> </ul> <p>[Setting condition]</p> <ul style="list-style-type: none"> <li>When any one of the three pairs of 2-phase outputs has simultaneously become an active level</li> </ul>



Bit	Bit Name	Initial value	R/W	Description
14 to 10	—	All 0	R	Reserved These bits are always read as 0. The write value should always be 0.
9	OCE1	0	R/W*2	Output Short High-Impedance Enable 1 This bit specifies whether to place the pins in high-impedance state when the OSF1 bit in OCSR1 is set to 1. 0: Does not place the pins in high-impedance state 1: Places the pins in high-impedance state
8	OIE1	0	R/W	Output Short Interrupt Enable 1 This bit enables or disables interrupt requests when the OSF1 bit in OCSR is set to 1. 0: Interrupt requests disabled 1: Interrupt requests enabled
7 to 0	—	All 0	R	Reserved These bits are always read as 0. The write value should always be 0.

- Notes: 1. Writing 0 to this bit after reading it as 1 clears the flag and is the only allowed way.  
2. Can be modified only once after a power-on reset.

### 10.3.3 Input Level Control/Status Register 3 (ICSR3)

ICSR3 is a 16-bit readable/writable register that selects the  $\overline{\text{POE8}}$  pin input mode, controls the enable/disable of interrupts, and indicates status.

Bit:	15	14	13	12	11	10	9	8	7	6	5	4	3	2	1	0
	-	-	-	POE8F	-	-	POE8E	PIE3	-	-	-	-	-	-	POE8M[1:0]	
Initial value:	0	0	0	0	0	0	0	0	0	0	0	0	0	0	0	0
R/W:	R	R	R	R/(W)*1	R	R	R/W*2	R/W	R	R	R	R	R	R	R/W*2	R/W*2

- Notes: 1. Writing 0 to this bit after reading it as 1 clears the flag and is the only allowed way.  
2. Can be modified only once after a power-on reset.

Bit	Bit Name	Initial value	R/W	Description
15 to 13	—	All 0	R	Reserved These bits are always read as 0. The write value should always be 0.
12	POE8F	0	R/(W)* <sup>1</sup>	<p>POE8 Flag</p> <p>This flag indicates that a high impedance request has been input to the POE8 pin.</p> <p>[Clearing conditions]</p> <ul style="list-style-type: none"> <li>By writing 0 to POE8F after reading POE8F = 1 (when the falling edge is selected by bits 1 and 0 in ICSR3).</li> <li>By writing 0 to POE8F after reading POE8F = 1 after a high level input to POE8 is sampled at Pf/8, Pf/16, or Pf/128 clock (when low-level sampling is selected by bits 1 and 0 in ICSR3)</li> </ul> <p>[Setting condition]</p> <ul style="list-style-type: none"> <li>When the input condition set by bits 1 and 0 in ICSR3 occurs at the <math>\overline{\text{POE8}}</math> pin</li> </ul>
11, 10	—	All 0	R	Reserved These bits are always read as 0. The write value should always be 0.
9	POE8E	0	R/W* <sup>2</sup>	<p>POE8 High-Impedance Enable</p> <p>This bit specifies whether to place the pins in high-impedance state when the POE8F bit in ICSR3 is set to 1.</p> <p>0: Does not place the pins in high-impedance state 1: Places the pins in high-impedance state</p>
8	PIE3	0	R/W	<p>Port Interrupt Enable 3</p> <p>(Supported only by the SH7125. Write 0 to this bit in the SH7124.)</p> <p>This bit enables or disables interrupt requests when the POE8 bit in ICSR3 is set to 1.</p> <p>0: Interrupt requests disabled 1: Interrupt requests enabled</p>

Bit	Bit Name	Initial value	R/W	Description
7 to 2	—	All 0	R	Reserved These bits are always read as 0. The write value should always be 0.
1, 0	POE8M[1:0]	00	R/W*2	POE8 mode 1 and 0 These bits select the input mode of the $\overline{\text{POE8}}$ pin. 00: Accept request on falling edge of POE8 input 01: Accept request when POE8 input has been sampled for 16 $P\phi/8$ clock pulses and all are low level. 10: Accept request when POE8 input has been sampled for 16 $P\phi/16$ clock pulses and all are low level. 11: Accept request when POE8 input has been sampled for 16 $P\phi/128$ clock pulses and all are low level.

Notes: 1. Writing 0 to this bit after reading it as 1 clears the flag and is the only allowed way.  
2. Can be modified only once after a power-on reset.

### 10.3.4 Software Port Output Enable Register (SPOER)

SPOER is an 8-bit readable/writable register that controls high-impedance state of the pins.

Bit:	7	6	5	4	3	2	1	0
	-	-	-	-	-	-	MTU2 CH0HIZ	MTU2 CH34HIZ
Initial value:	0	0	0	0	0	0	0	0
R/W:	R	R	R	R	R	R/W	R/W	R/W

Bit	Bit Name	Initial value	R/W	Description
7 to 3	—	All 0	R	Reserved These bits are always read as 0. The write value should always be 0.
2	—	0	R/W	Reserved This bit is always read as 0. The write value should always be 0.

Bit	Bit Name	Initial value	R/W	Description
1	MTU2CH0HIZ	0	R/W	<p>MTU2 Channel 0 Output High-Impedance</p> <p>This bit specifies whether to place the pins for channel 0 in the MTU2 in high-impedance state.</p> <p>0: Does not place the pins in high-impedance state</p> <p>[Clearing conditions]</p> <ul style="list-style-type: none"> <li>• Power-on reset</li> <li>• By writing 0 to MTU2CH0HIZ after reading MTU2CH0HIZ = 1</li> </ul> <p>1: Places the pins in high-impedance state</p> <p>[Setting condition]</p> <ul style="list-style-type: none"> <li>• By writing 1 to MTU2CH0HIZ</li> </ul>
0	MTU2CH34HIZ	0	R/W	<p>MTU2 Channel 3 and 4 Output High-Impedance</p> <p>This bit specifies whether to place the high-current pins for the MTU2 in high-impedance state.</p> <p>0: Does not place the pins in high-impedance state</p> <p>[Clearing conditions]</p> <ul style="list-style-type: none"> <li>• Power-on reset</li> <li>• By writing 0 to MTU2CH34HIZ after reading MTU2CH34HIZ = 1</li> </ul> <p>1: Places the pins in high-impedance state</p> <p>[Setting condition]</p> <ul style="list-style-type: none"> <li>• By writing 1 to MTU2CH34HIZ</li> </ul>

### 10.3.5 Port Output Enable Control Register 1 (POECR1)

POECR1 is an 8-bit readable/writable register that controls high-impedance state of the pins.

Bit:	7	6	5	4	3	2	1	0
	-	-	-	-	MTU2 PE3ZE	MTU2 PE2ZE	MTU2 PE1ZE	MTU2 PE0ZE
Initial value:	0	0	0	0	0	0	0	0
R/W:	R	R	R	R	R/W*	R/W*	R/W*	R/W*

Note: \* Can be modified only once after a power-on reset.

Bit	Bit Name	Initial value	R/W	Description
7 to 4	—	All 0	R	Reserved  These bits are always read as 0. The write value should always be 0.
3	MTU2PE3ZE	0	R/W*	MTU2 PE3 High-Impedance Enable  This bit specifies whether to place the PE3/TIOC1D pin for channel 0 in the MTU2 in high-impedance state when either POE8F or MTU2CH0HIZ bit is set to 1.  0: Does not place the pin in high-impedance state 1: Places the pin in high-impedance state
2	MTU2PE2ZE	0	R/W*	MTU2 PE2 High-Impedance Enable  This bit specifies whether to place the PE2/TIOC1C pin for channel 0 in the MTU2 in high-impedance state when either POE8F or MTU2CH0HIZ bit is set to 1.  0: Does not place the pin in high-impedance state 1: Places the pin in high-impedance state
1	MTU2PE1ZE	0	R/W*	MTU2 PE1 High-Impedance Enable  This bit specifies whether to place the PE1/TIOC1B pin for channel 0 in the MTU2 in high-impedance state when either POE8F or MTU2CH0HIZ bit is set to 1.  0: Does not place the pin in high-impedance state 1: Places the pin in high-impedance state

Bit	Bit Name	Initial value	R/W	Description
0	MTU2PE0ZE	0	R/W*	<p>MTU2 PE0 High-Impedance Enable</p> <p>This bit specifies whether to place the PE0/TIOC1A pin for channel 0 in the MTU2 in high-impedance state when either POE8F or MTU2CH0HIZ bit is set to 1.</p> <p>0: Does not place the pin in high-impedance state 1: Places the pin in high-impedance state</p>

Note: \* Can be modified only once after a power-on reset.

### 10.3.6 Port Output Enable Control Register 2 (POECR2)

POECR2 is a 16-bit readable/writable register that controls high-impedance state of the pins.

Bit:	15	14	13	12	11	10	9	8	7	6	5	4	3	2	1	0
	-	MTU2 P1CZE	MTU2 P2CZE	MTU2 P3CZE	-	-	-	-	-	-	-	-	-	-	-	-
Initial value:	0	1	1	1	0	1	1	1	0	0	0	0	0	0	0	0
R/W:	R	R/W*	R/W*	R/W*	R	R/W*	R/W*	R/W*	R	R	R	R	R	R	R	R

Note: \* Can be modified only once after a power-on reset.

Bit	Bit Name	Initial value	R/W	Description
15	—	0	R	<p>Reserved</p> <p>This bit is always read as 0. The write value should always be 0.</p>
14	MTU2P1CZE	1	R/W*	<p>MTU2 Port 1 Output Comparison/High-Impedance Enable</p> <p>This bit specifies whether to compare output levels for the MTU2 high-current PE9/TIOC3B and PE11/TIOC3D pins and to place them in high-impedance state when the OSF1 bit is set to 1 while the OEC1 bit is 1 or when any one of the POE0F, POE1F, POE3F, and MTU2CH34HIZ bits is set to 1.</p> <p>0: Does not compare output levels or place the pins in high-impedance state 1: Compares output levels and places the pins in high-impedance state</p>

Bit	Bit Name	Initial value	R/W	Description
13	MTU2P2CZE	1	R/W*	<p>MTU2 Port 2 Output Comparison/High-Impedance Enable</p> <p>This bit specifies whether to compare output levels for the MTU2 high-current PE12/TIOC4A and PE14/TIOC4C pins and to place them in high-impedance state when the OSF1 bit is set to 1 while the OEC1 bit is 1 or when any one of the POE0F, POE1F, POE3F, and MTU2CH34HIZ bits is set to 1.</p> <p>0: Does not compare output levels or place the pins in high-impedance state</p> <p>1: Compares output levels and places the pins in high-impedance state</p>
12	MTU2P3CZE	1	R/W*	<p>MTU2 Port 3 Output Comparison/High-Impedance Enable</p> <p>This bit specifies whether to compare output levels for the MTU2 high-current PE13/TIOC4B and PE15/TIOC4D pins and to place them in high-impedance state when the OSF1 bit is set to 1 while the OEC1 bit is 1 or when any one of the POE0F, POE1F, POE3F, and MTU2CH34HIZ bits is set to 1.</p> <p>0: Does not compare output levels or place the pins in high-impedance state</p> <p>1: Compares output levels and places the pins in high-impedance state</p>
11	—	0	R	<p>Reserved</p> <p>This bit is always read as 0. The write value should always be 0.</p>
10 to 8	—	All 1	R/W*	<p>Reserved</p> <p>These bits are always read as 1. The write value should always be 1.</p>
7 to 0	—	0	R	<p>Reserved</p> <p>These bits are always read as 0. The write value should always be 0.</p>

Note: \* Can be modified only once after a power-on reset.

## 10.4 Operation

Table 10.4 shows the target pins for high-impedance control and conditions to place the pins in high-impedance state.

**Table 10.4 Target Pins and Conditions for High-Impedance Control**

Pins	Conditions	Detailed Conditions
MTU2 high-current pins (PE9/TIOC3B and PE11/TIOC3D)	Input level detection, output level comparison, or SPOER setting	MTU2P1CZE • ((POE3F + POE1F + POE0F) + (OSF1 • OCE1) + (MTU2CH34HIZ))
MTU2 high-current pins (PE12/TIOC4A and PE14/TIOC4C)	Input level detection, output level comparison, or SPOER setting	MTU2P2CZE • ((POE3F + POE1F + POE0F) + (OSF1 • OCE1) + (MTU2CH34HIZ))
MTU2 high-current pins (PE13/TIOC4B and PE15/TIOC4D)	Input level detection, output level comparison, or SPOER setting	MTU2P3CZE • ((POE3F + POE1F + POE0F) + (OSF1 • OCE1) + (MTU2CH34HIZ))
MTU2 channel 0 pin (PE0/TIOC0A)	Input level detection or SPOER setting	MTU2PE0ZE ((POE8F • POE8E) + (MTU2CH0HIZ))
MTU2 channel 0 pin (PE1/TIOC0B)	Input level detection or SPOER setting	MTU2PE1ZE ((POE8F • POE8E) + (MTU2CH0HIZ))
MTU2 channel 0 pin (PE2/TIOC0C)	Input level detection or SPOER setting	MTU2PE2ZE ((POE8F • POE8E) + (MTU2CH0HIZ))
MTU2 channel 0 pin (PE3/TIOC0D)	Input level detection or SPOER setting	MTU2PE3ZE ((POE8F • POE8E) + (MTU2CH0HIZ))

### 10.4.1 Input Level Detection Operation

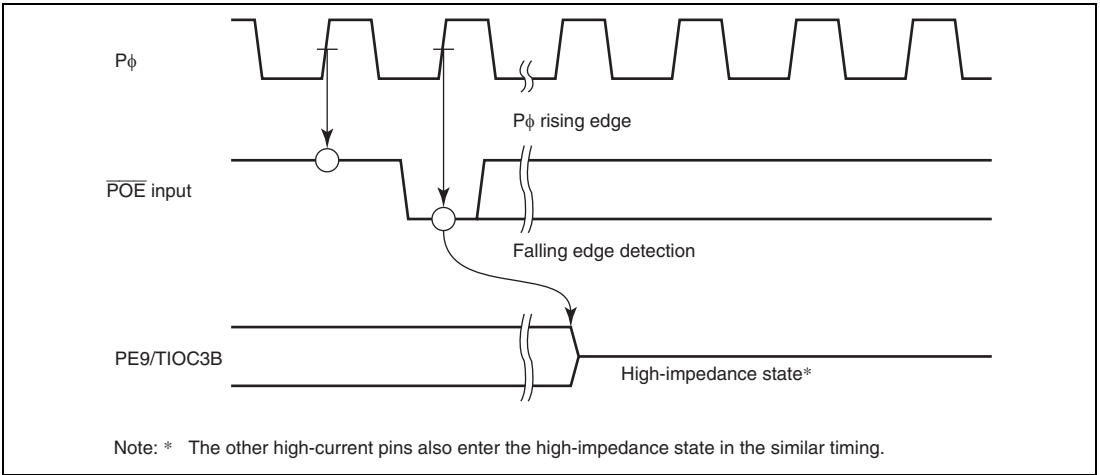
If the input conditions set by ICSR1 occur on the  $\overline{POE0}$ ,  $\overline{POE1}$ ,  $\overline{POE3^*}$ , and  $\overline{POE8}$  pins, the high-current pins and the pins for channel 0 of the MTU2 are placed in high-impedance state. Note however, that these high-current and MTU2 pins enter high-impedance state only when general input/output function or MTU2 function is selected for these pins.

#### (1) Falling Edge Detection

When a change from a high to low level is input to the  $\overline{POE0}$ ,  $\overline{POE1}$ ,  $\overline{POE3^*}$ , and  $\overline{POE8}$  pins, the high-current pins and the pins for channel 0 of the MTU2 are placed in high-impedance state. Figure 10.2 shows a sample timing after the level changes in input to the  $\overline{POE0}$ ,  $\overline{POE1}$ ,  $\overline{POE3^*}$ , and  $\overline{POE8}$  pins until the respective pins enter high-impedance state.

Note: \* This pin is supported only by the SH7125.



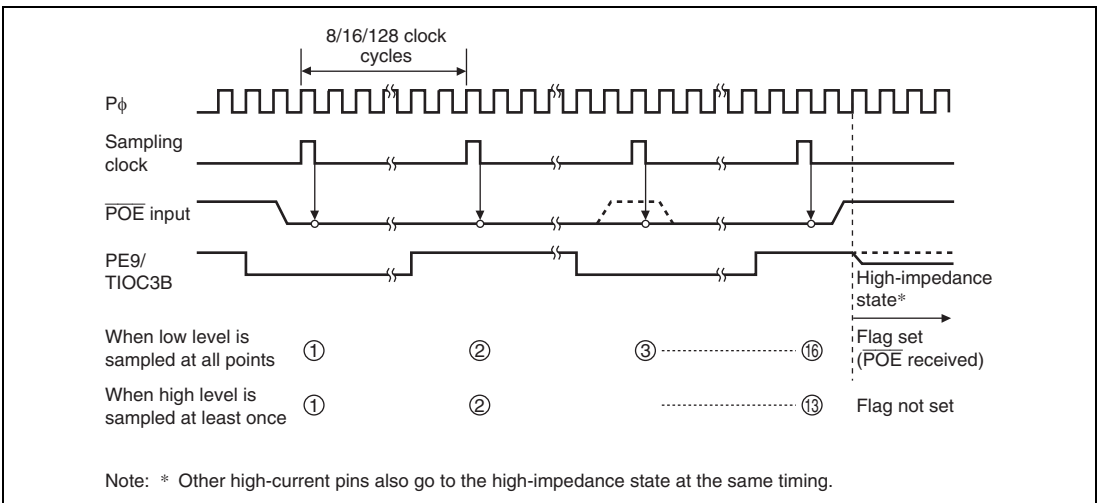


**Figure 10.2 Falling Edge Detection**

**(2) Low-Level Detection**

Figure 10.3 shows the low-level detection operation. Sixteen continuous low levels are sampled with the sampling clock selected by ICSR1. If even one high level is detected during this interval, the low level is not accepted.

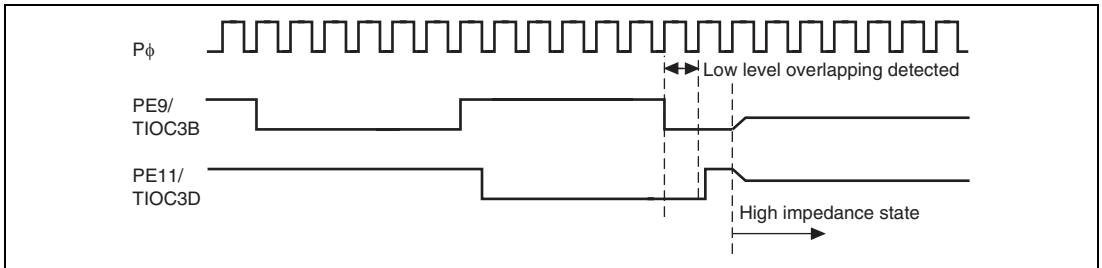
The timing when the high-current pins enter the high-impedance state after the sampling clock is input is the same in both falling-edge detection and in low-level detection.



**Figure 10.3 Low-Level Detection Operation**

### 10.4.2 Output-Level Compare Operation

Figure 10.4 shows an example of the output-level compare operation for the combination of TIOC3B and TIOC3D. The operation is the same for the other pin combinations.



**Figure 10.4 Output-Level Compare Operation**

### 10.4.3 Release from High-Impedance State

High-current pins that have entered high-impedance state due to input-level detection can be released either by returning them to their initial state with a power-on reset, or by clearing all of the flags in bits 12 to 15 (POE0F to POE3F and POE8F) in ICSR1. However, note that when low-level sampling is selected by bits 0 to 7 in ICSR1, just writing 0 to a flag is ignored (the flag is not cleared); flags can be cleared by writing 0 to it only after a high level is input to the POE pin and is sampled.

High-current pins that have entered high-impedance state due to output-level detection can be released either by returning them to their initial state with a power-on reset, or by clearing the flag in bit 15 (OCF1) in OCSR1. However, note that just writing 0 to a flag is ignored (the flag is not cleared); flags can be cleared only after an inactive level is output from the high-current pins. Inactive-level outputs can be achieved by setting the MTU2 internal registers.

## 10.5 Interrupts

The POE issues a request to generate an interrupt when the specified condition is satisfied during input level detection or output level comparison. Table 10.5 shows the interrupt sources and their conditions.

**Table 10.5 Interrupt Sources and Conditions**

<b>Name</b>	<b>Interrupt Source</b>	<b>Interrupt Flag</b>	<b>Condition</b>
OEI1	Output enable interrupt 1	POE3F, POE1F, POE0F, and OSF1	$PIE1 \bullet (POE3F + POE1F + POE0F) + OIE1 \bullet OSF1$
OEI3	Output enable interrupt 2	POE8F	$PIE3 \bullet POE8F$

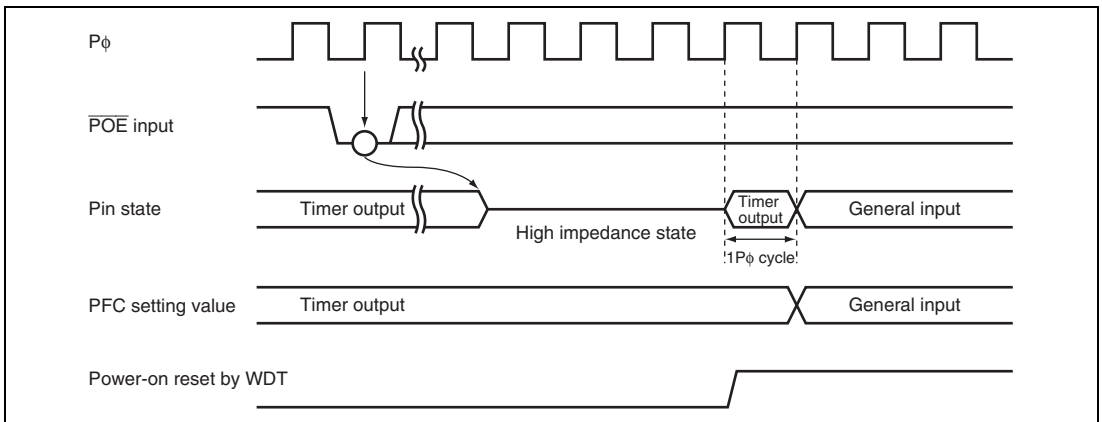
## 10.6 Usage Note

### 10.6.1 Pin State when a Power-On Reset is Issued from the Watchdog Timer

When a power-on reset is issued from the watchdog timer (WDT), initialization of the pin function controller (PFC) sets initial values that select the general input function for the I/O ports. However, when a power-on reset is issued from the WDT while a pin is being handled as high impedance by the port output enable (POE), the pin is placed in the output state for one cycle of the peripheral clock (P<sub>f</sub>), after which the function is switched to general input.

This also occurs when a power-on reset is issued from the WDT for pins that are being handled as high impedance due to short-circuit detection by the MTU2.

Figure 10.5 shows the state of a pin for which the POE input has selected high impedance handling with the timer output selected when a power-on reset is issued from the WDT.



**Figure 10.5 Pin State when a Power-On Reset is Issued from the Watchdog Timer**

## Section 11 Watchdog Timer (WDT)

This LSI includes the watchdog timer (WDT).

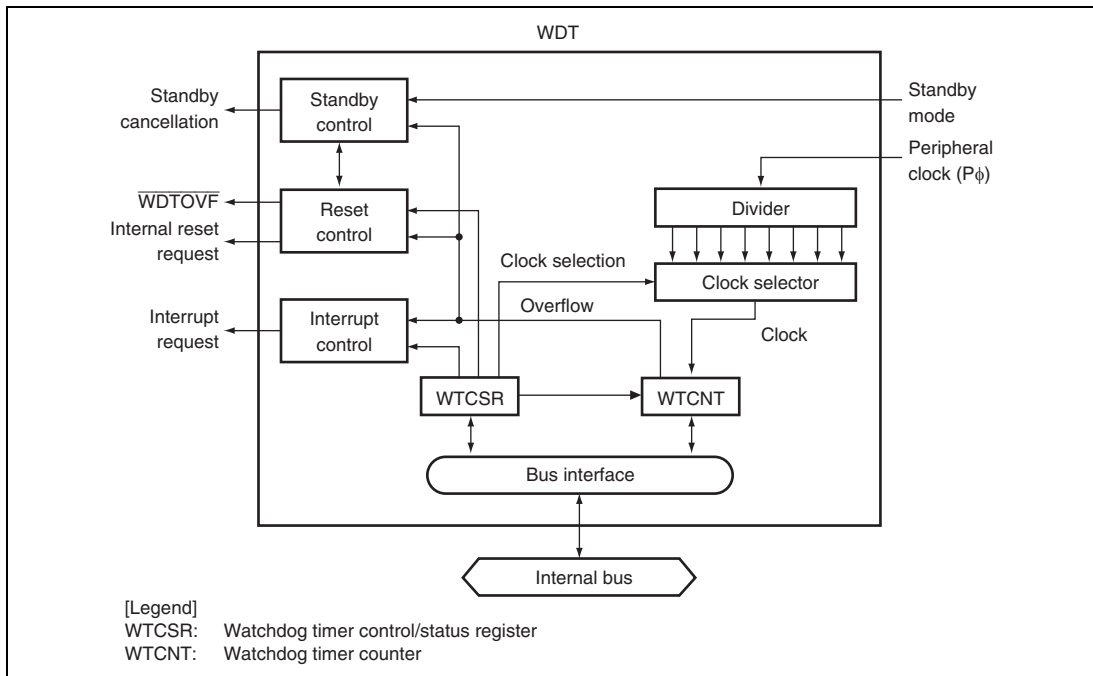
This LSI can be reset by the overflow of the counter when the value of the counter has not been updated because of a system runaway.

The watchdog timer (WDT) is a single-channel timer that uses a peripheral clock as an input and counts the clock settling time when clearing software standby mode. It can also be used as an interval timer.

### 11.1 Features

- Can be used to ensure the clock settling time: Use the WDT to revoke software standby mode.
- Can switch between watchdog timer mode and interval timer mode.
- Generates internal resets in watchdog timer mode: Internal resets occur after counter overflow.
- An interrupt is generated in interval timer mode  
An interval timer interrupt is generated when the counter overflows.
- Choice of eight counter input clocks  
Eight clocks ( $\times 1$  to  $\times 1/4096$ ) that are obtained by dividing the peripheral clock can be chosen.
- Choice of two resets  
Power-on reset and manual reset are available.

Figure 11.1 shows a block diagram of the WDT.



**Figure 11.1 Block Diagram of WDT**

## 11.2 Input/Output Pin for WDT

Table 11.1 lists the WDT pin configuration.

**Table 11.1 WDT Pin Configuration**

<b>Pin Name</b>	<b>Abbreviation</b>	<b>I/O</b>	<b>Description</b>
Watchdog timer overflow	$\overline{\text{WDTOVF}}$	Output	When an overflow occurs in watchdog timer mode, an internal reset is generated and this pin outputs the low level for one clock cycle specified by the CKS2 to CKS0 bits in WTCSR.

## 11.3 Register Descriptions

The WDT has the following two registers. Refer to section 20, List of Registers, for the details of the addresses of these registers and the state of registers in each operating mode.

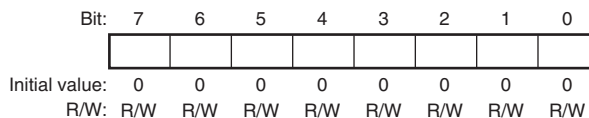
**Table 11.2 Register Configuration**

Register Name	Abbreviation	R/W	Initial Value	Address	Access Size
Watchdog timer counter	WTCNT	R/W	H'00	H'FFFFE810	8, 16
Watchdog timer control/status register	WTCSR	R/W	H'00	H'FFFFE812	8, 16

### 11.3.1 Watchdog Timer Counter (WTCNT)

WTCNT is an 8-bit readable/writable register that increments on the selected clock. When an overflow occurs, it generates a reset in watchdog timer mode and an interrupt in interval time mode. The WTCNT counter is not initialized by an internal reset due to the WDT overflow. The WTCNT counter is initialized to H'00 only by a power-on reset using the  $\overline{\text{RES}}$  pin. Use a word access to write to the WTCNT counter, with H'5A in the upper byte. Use a byte access to read WTCNT.

Note: WTCNT differs from other registers in that it is more difficult to write to. See section 11.3.3, Notes on Register Access, for details.





### 11.3.2 Watchdog Timer Control/Status Register (WTCSR)

WTCSR is an 8-bit readable/writable register composed of bits to select the clock used for the count, bits to select the timer mode, and overflow flags. WTCSR holds its value in an internal reset due to the WDT overflow. WTCSR is initialized to H'00 only by a power-on reset using the RES pin.

When used to count the clock settling time for canceling a software standby, it retains its value after counter overflow. Use a word access to write to WTCSR, with H'A5 in the upper byte. Use a byte access to read WTCSR.

Note: WTCSR differs from other registers in that it is more difficult to write to. See section 11.3.3, Notes on Register Access, for details.

Bit:	7	6	5	4	3	2	1	0
	TME	WT/IT	RSTS	WOVF	IOVF	CKS[2:0]		
Initial value:	0	0	0	0	0	0	0	0
R/W:	R/W	R/W	R/W	R/W	R/W	R/W	R/W	R/W

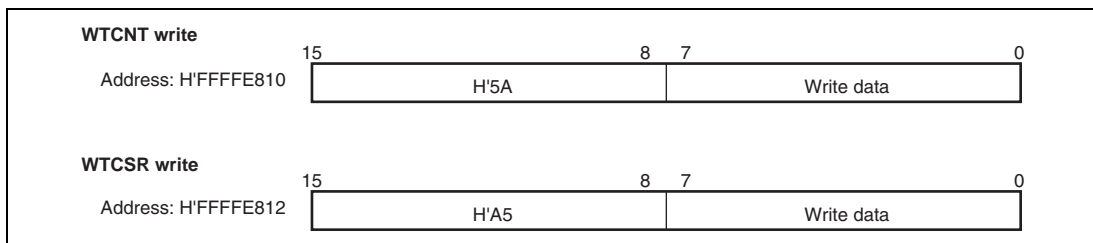
Bit	Bit Name	Initial Value	R/W	Description
7	TME	0	R/W	<p>Timer Enable</p> <p>Starts and stops timer operation. Clear this bit to 0 when using the WDT to revoke software standby mode</p> <p>0: Timer disabled: Count-up stops and WTCNT value is retained</p> <p>1: Timer enabled</p>
6	WT/IT	0	R/W	<p>Timer Mode Select</p> <p>Selects whether to use the WDT as a watchdog timer or an interval timer.</p> <p>0: Interval timer mode</p> <p>1: Watchdog timer mode</p> <p>Note: If WT/IT is modified when the WDT is operating, the up-count may not be performed correctly.</p>

Bit	Bit Name	Initial Value	R/W	Description
5	RSTS	0	R/W	<p>Reset Select</p> <p>Selects the type of reset when the WTCNT overflows in watchdog timer mode. In interval timer mode, this setting is ignored.</p> <p>0: Power-on reset 1: Manual reset</p>
4	WOVF	0	R/W	<p>Watchdog Timer Overflow</p> <p>Indicates that the WTCNT has overflowed in watchdog timer mode. This bit is not set in interval timer mode.</p> <p>0: No overflow 1: WTCNT has overflowed in watchdog timer mode</p>
3	IOVF	0	R/W	<p>Interval Timer Overflow</p> <p>Indicates that the WTCNT has overflowed in interval timer mode. This bit is not set in watchdog timer mode.</p> <p>0: No overflow 1: WTCNT has overflowed in interval timer mode</p>
2 to 0	CKS[2:0]	000	R/W	<p>Clock Select 2 to 0</p> <p>These bits select the clock to be used for the WTCNT count from the eight types obtainable by dividing the peripheral clock (<math>P\phi</math>). The overflow period that is shown inside the parenthesis in the table is the value when the peripheral clock (<math>P\phi</math>) is 40 MHz.</p> <p>000: <math>P\phi</math> (6.4 <math>\mu</math>s) 001: <math>P\phi</math> /4 (25.6 <math>\mu</math>s) 010: <math>P\phi</math> /16 (102.4 <math>\mu</math>s) 011: <math>P\phi</math> /32 (204.8 <math>\mu</math>s) 100: <math>P\phi</math> /64 (409.6 <math>\mu</math>s) 101: <math>P\phi</math> /256 (1.64 ms) 110: <math>P\phi</math> /1024 (6.55 ms) 111: <math>P\phi</math> /4096 (26.21 ms)</p> <p>Note: If bits CKS2 to CKS0 are modified when the WDT is operating, the up-count may not be performed correctly. Ensure that these bits are modified only when the WDT is not operating.</p>

### 11.3.3 Notes on Register Access

The watchdog timer counter (WTCNT) and watchdog timer control/status register (WTCSR) are more difficult to write to than other registers. The procedure for writing to these registers is given below.

**Writing to WTCNT and WTCSR:** These registers must be written by a word transfer instruction. They cannot be written by a byte or longword transfer instruction. When writing to WTCNT, set the upper byte to H'5A and transfer the lower byte as the write data, as shown in figure 11.2. When writing to WTCSR, set the upper byte to H'A5 and transfer the lower byte as the write data. This transfer procedure writes the lower byte data to WTCNT or WTCSR.



**Figure 11.2 Writing to WTCNT and WTCSR**

## 11.4 Operation

### 11.4.1 Canceling Software Standbys

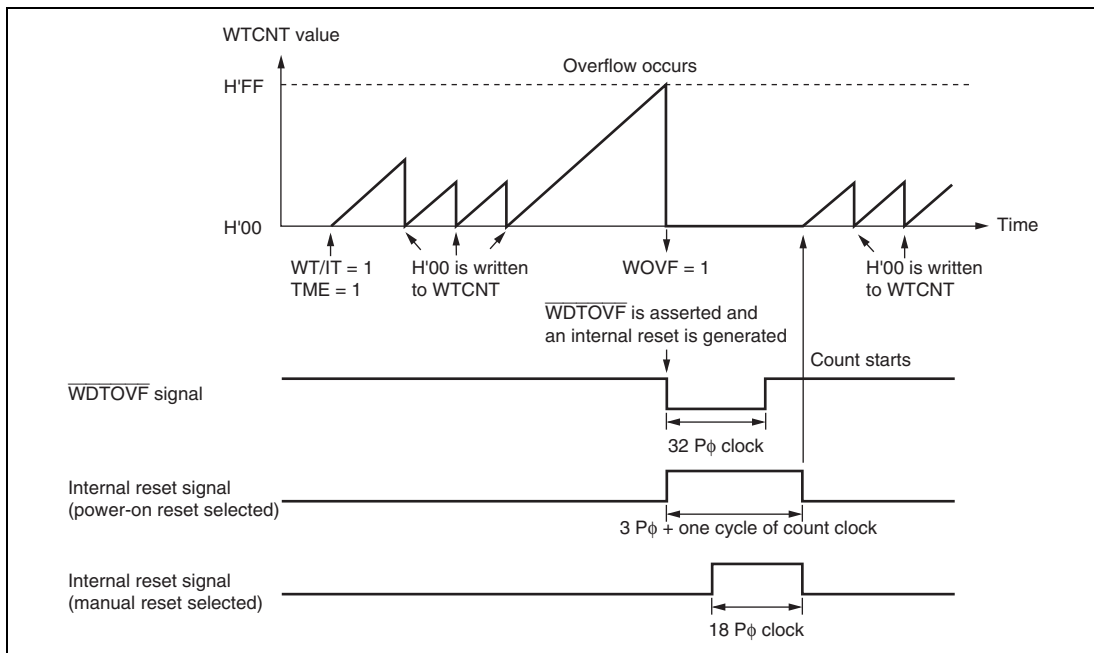
The WDT can be used to revoke software standby mode with an NMI interrupt or external interrupt (IRQ). The procedure is described below. (The WDT does not run when resets are used for canceling, so keep the  $\overline{\text{RES}}$  pin low until the clock stabilizes.)

1. Before transition to software standby mode, always clear the TME bit in WTCSR to 0. When the TME bit is 1, an erroneous reset or interval timer interrupt may be generated when the count overflows.
2. Set the type of count clock used in the CKS2 to CKS0 bits in WTCSR and the initial values for the counter in the WTCNT counter. These values should ensure that the time till count overflow is longer than the clock oscillation settling time.
3. Transition to software standby mode by executing a SLEEP instruction to stop the clock.
4. The WDT starts counting by detecting a change in the level input to the NMI or IRQ pin.
5. When the WDT count overflows, the CPG starts supplying the clock and the LSI resumes operation. The WOVF flag in WTCSR is not set when this happens.

### 11.4.2 Using Watchdog Timer Mode

While operating in watchdog timer mode, the WDT generates an internal reset of the type specified by the RSTS bit in WTCSR and asserts a signal through the  $\overline{\text{WDTOVF}}$  pin every time the counter overflows.

1. Set the WT/IT bit in WTCSR to 1, set the reset type in the RSTS bit, set the type of count clock in the CKS2 to CKS0 bits, and set the initial value of the counter in the WTCNT counter.
2. Set the TME bit in WTCSR to 1 to start the count in watchdog timer mode.
3. While operating in watchdog timer mode, rewrite the counter periodically to prevent the counter from overflowing.
4. When the counter overflows, the WDT sets the WOVF flag in WTCSR to 1, asserts a signal through the  $\overline{\text{WDTOVF}}$  pin for one cycle of the count clock specified by the CKS2 to CKS0 bits, and generates a reset of the type specified by the RSTS bit. The counter then resumes counting.



**Figure 11.3 Operation in Watchdog Timer Mode**  
**(When WTCNT Count Clock is Specified to P $\phi$ /32 by CKS2 to CKS0)**

### 11.4.3 Using Interval Timer Mode

When operating in interval timer mode, interval timer interrupts are generated at every overflow of the counter. This enables interrupts to be generated at set periods.

1. Clear the WT/IT bit in WTCSR to 0, set the type of count clock in the CKS2 to CKS0 bits, and set the initial value of the counter in the WTCNT counter.
2. Set the TME bit in WTCSR to 1 to start the count in interval timer mode.
3. When the counter overflows, the WDT sets the IOVF flag in WTCSR to 1 and an interval timer interrupt request is sent to the INTC. The counter then resumes counting.

## 11.5 Usage Note

If WTCNT is set to H'FF in interval timer mode, overflow does not occur when WTCNT reaches the immediate H'00, but occurs when WTCNT changes from H'FF to H'00 after 257 cycles of count clock.

Whereas if WTCNT is set to H'FF in watchdog timer mode, overflow occurs when WTCNT changes from H'FF to H'00 after one cycle of count clock.

## Section 12 Serial Communication Interface (SCI)

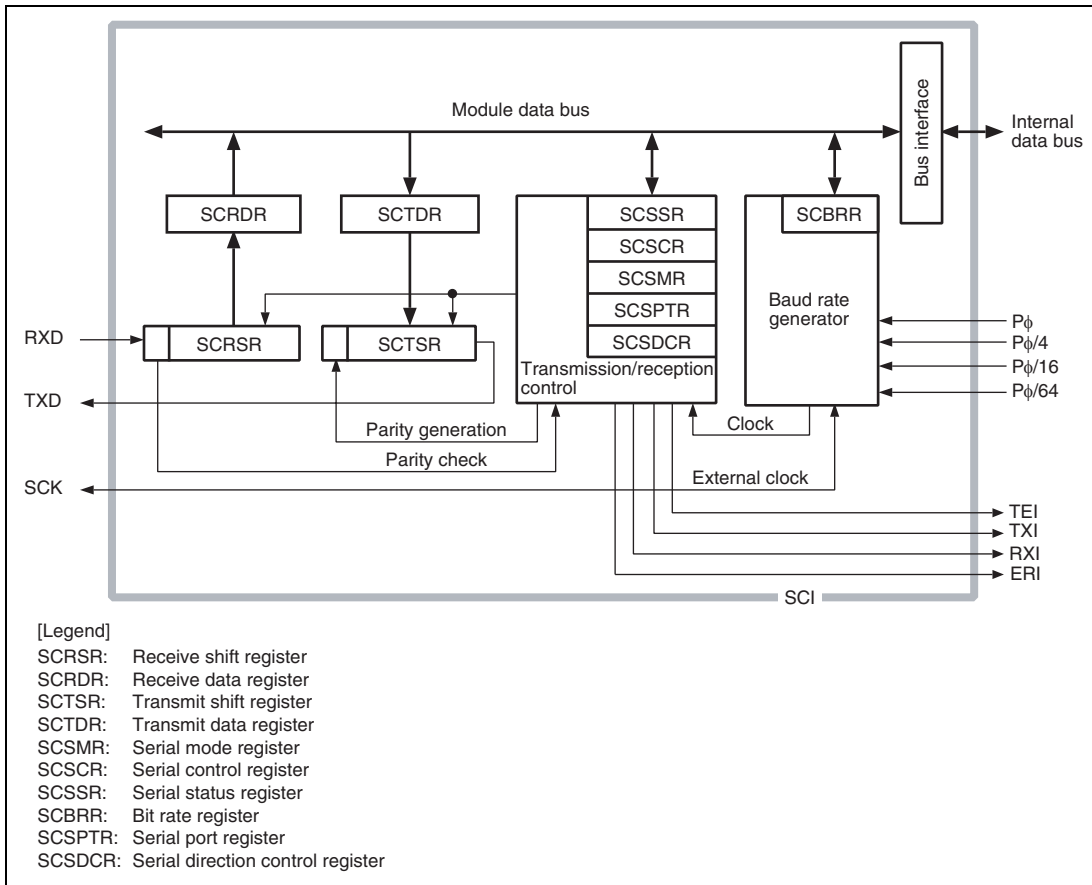
This LSI has three independent serial communication interface (SCI) channels. The SCI can handle both asynchronous and clock synchronous serial communication. In asynchronous serial communication mode, serial data communication can be carried out with standard asynchronous communication chips such as a Universal Asynchronous Receiver/Transmitter (UART) or Asynchronous Communication Interface Adapter (ACIA). A function is also provided for serial communication between processors (multiprocessor communication function).

### 12.1 Features

- Choice of asynchronous or clock synchronous serial communication mode
- Asynchronous mode (channels 0 to 2 in the SH7125, channels 0 to 2 in the SH7124):
  - Serial data communication is performed by start-stop in character units. The SCIF can communicate with a universal asynchronous receiver/transmitter (UART), an asynchronous communication interface adapter (ACIA), or any other communications chip that employs a standard asynchronous serial system. There are twelve selectable serial data communication formats.
  - Data length: 7 or 8 bits
  - Stop bit length: 1 or 2 bits
  - Parity: Even, odd, or none
  - Multiprocessor communications
  - Receive error detection: Parity, overrun, and framing errors
  - Break detection: Break is detected by reading the RXD pin level directly when a framing error occurs.
- Clock synchronous mode (channels 0 to 2 in the SH7125, channels 0 and 2 in the SH7124):
  - Serial data communication is synchronized with a clock signal. The SCIF can communicate with other chips having a clock synchronous communication function.
  - Data length: 8 bits
  - Receive error detection: Overrun errors
- Full duplex communication: The transmitting and receiving sections are independent, so the SCI can transmit and receive simultaneously. Both sections use double buffering, so high-speed continuous data transfer is possible in both transmit and receive directions.
- On-chip baud rate generator with selectable bit rates
- Internal or external transmit/receive clock source: From either baud rate generator (internal clock) or SCK pin (external clock)
- Choice of LSB-first or MSB-first data transfer (except for 7-bit data in asynchronous mode)

- Four types of interrupts: There are four interrupt sources, transmit-data-empty, transmit end, receive-data-full, and receive error interrupts, and each interrupt can be requested independently.
- Module standby mode can be set

Figure 12.1 shows a block diagram of the SCI.



**Figure 12.1 Block Diagram of SCI**



## 12.2 Input/Output Pins

The SCI has the serial pins summarized in table 12.1.

**Table 12.1 Pin Configuration**

Channel	Pin Name* <sup>1</sup>	I/O	Function
0	SCK0	I/O	SCI0 clock input/output
	RXD0	Input	SCI0 receive data input
	TXD0	Output	SCI0 transmit data output
1	SCK1* <sup>2</sup>	I/O	SCI1 clock input/output
	RXD1	Input	SCI1 receive data input
	TXD1	Output	SCI1 transmit data output
2	SCK2	I/O	SCI2 clock input/output
	RXD2	Input	SCI2 receive data input
	TXD2	Output	SCI2 transmit data output

- Notes:
1. Pin names SCK, RXD, and TXD are used in the description for all channels, omitting the channel designation.
  2. This pin is supported only by the SH7125. Channel 1 in the SH7124 is only for asynchronous mode.

## 12.3 Register Descriptions

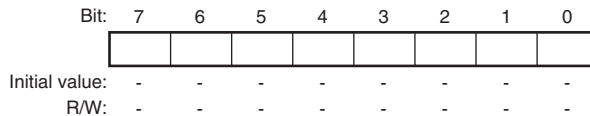
The SCI has the following registers for each channel. For details on register addresses and register states during each processing, see section 20, List of Registers.

**Table 12.2 Register Configuration**

Channel	Register Name	Abbreviation	R/W	Initial Value	Address	Access Size
0	Serial mode register_0	SCSMR_0	R/W	H'00	H'FFFFFFC000	8
	Bit rate register_0	SCBRR_0	R/W	H'FF	H'FFFFFFC002	8
	Serial control register_0	SCSCR_0	R/W	H'00	H'FFFFFFC004	8
	Transmit data register_0	SCTDR_0	—	—	H'FFFFFFC006	8
	Serial status register_0	SCSSR_0	R/W	H'84	H'FFFFFFC008	8
	Receive data register_0	SCRDR_0	—	—	H'FFFFFFC00A	8
	Serial direction control register_0	SCSDCR_0	R/W	H'F2	H'FFFFFFC00C	8
	Serial port register_0	SCSPTR_0	R/W	H'01	H'FFFFFFC00E	8
1	Serial mode register_1	SCSMR_1	R/W	H'00	H'FFFFFFC080	8
	Bit rate register_1	SCBRR_1	R/W	H'FF	H'FFFFFFC082	8
	Serial control register_1	SCSCR_1	R/W	H'00	H'FFFFFFC084	8
	Transmit data register_1	SCTDR_1	—	—	H'FFFFFFC086	8
	Serial status register_1	SCSSR_1	R/W	H'84	H'FFFFFFC088	8
	Receive data register_1	SCRDR_1	—	—	H'FFFFFFC08A	8
	Serial direction control register_1	SCSDCR_1	R/W	H'F2	H'FFFFFFC08C	8
	Serial port register_1	SCSPTR_1	R/W	H'01	H'FFFFFFC08E	8
2	Serial mode register_2	SCSMR_2	R/W	H'00	H'FFFFFFC100	8
	Bit rate register_2	SCBRR_2	R/W	H'FF	H'FFFFFFC102	8
	Serial control register_2	SCSCR_2	R/W	H'00	H'FFFFFFC104	8
	Transmit data register_2	SCTDR_2	—	—	H'FFFFFFC106	8
	Serial status register_2	SCSSR_2	R/W	H'84	H'FFFFFFC108	8
	Receive data register_2	SCRDR_2	—	—	H'FFFFFFC10A	8
	Serial direction control register_2	SCSDCR_2	R/W	H'F2	H'FFFFFFC10C	8
	Serial port register_2	SCSPTR_2	R/W	H'01	H'FFFFFFC10E	8

### 12.3.1 Receive Shift Register (SCRSR)

SCRSR receives serial data. Data input at the RXD pin is loaded into SCRSR in the order received, LSB (bit 0) first, converting the data to parallel form. When one byte has been received, it is automatically transferred to SCRDR. The CPU cannot read or write to SCRSR directly.

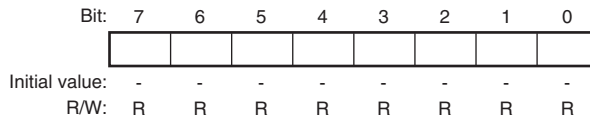


### 12.3.2 Receive Data Register (SCRDR)

SCRDR is a register that stores serial receive data. After receiving one byte of serial data, the SCI transfers the received data from the receive shift register (SCRSR) into SCRDR for storage and completes operation. After that, SCRSR is ready to receive data.

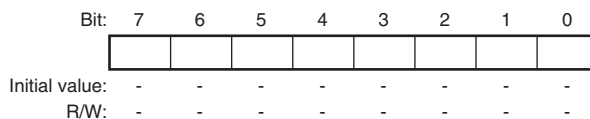
Since SCRSR and SCRDR work as a double buffer in this way, data can be received continuously.

SCRDR is a read-only register and cannot be written to by the CPU.



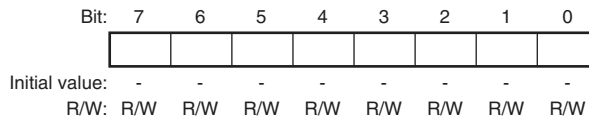
### 12.3.3 Transmit Shift Register (SCTSR)

SCTSR transmits serial data. The SCI loads transmit data from the transmit data register (SCTDR) into SCTSR, and then transmits the data serially from the TXD pin, LSB (bit 0) first. After transmitting one data byte, the SCI automatically loads the next transmit data from SCTDR into SCTSR and starts transmitting again. If the TDRE flag in the serial status register (SCSSR) is set to 1, the SCI does not transfer data from SCTDR to SCTSR. The CPU cannot read or write to SCTSR directly.



### 12.3.4 Transmit Data Register (SCTDR)

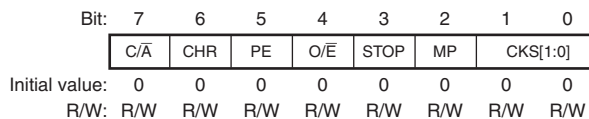
SCTDR is an 8-bit register that stores data for serial transmission. When the SCI detects that the transmit shift register (SCTSR) is empty, it moves transmit data written in the SCTDR into SCTSR and starts serial transmission. If the next transmit data has been written to SCTDR during serial transmission from SCTSR, the SCI can transmit data continuously. SCTDR can always be written or read to by the CPU.



### 12.3.5 Serial Mode Register (SCSMR)

SCSMR is an 8-bit register that specifies the SCI serial communication format and selects the clock source for the baud rate generator.

The CPU can always read and write to SCSMR.



Bit	Bit Name	Initial value	R/W	Description
7	C/ $\bar{A}$	0	R/W	Communication Mode Selects whether the SCI operates in asynchronous or clock synchronous mode. 0: Asynchronous mode 1: Clock synchronous mode (Channel 1 in the SH7124 is not available.)

Bit	Bit Name	Initial value	R/W	Description
6	CHR	0	R/W	<p>Character Length</p> <p>Selects 7-bit or 8-bit data in asynchronous mode. In the clock synchronous mode, the data length is always eight bits, regardless of the CHR setting. When 7-bit data is selected, the MSB (bit 7) of the transmit data register is not transmitted.</p> <p>0: 8-bit data 1: 7-bit data</p>
5	PE	0	R/W	<p>Parity Enable</p> <p>Selects whether to add a parity bit to transmit data and to check the parity of receive data, in asynchronous mode. In clock synchronous mode, a parity bit is neither added nor checked, regardless of the PE setting.</p> <p>0: Parity bit not added or checked 1: Parity bit added and checked*</p> <p>Note: * When PE is set to 1, an even or odd parity bit is added to transmit data, depending on the parity mode (O/<math>\bar{E}</math>) setting. Receive data parity is checked according to the even/odd (O/<math>\bar{E}</math>) mode setting.</p>
4	O/ $\bar{E}$	0	R/W	<p>Parity mode</p> <p>Selects even or odd parity when parity bits are added and checked. The O/<math>\bar{E}</math> setting is used only in asynchronous mode and only when the parity enable bit (PE) is set to 1 to enable parity addition and checking. The O/<math>\bar{E}</math> setting is ignored in clock synchronous mode, or in asynchronous mode when parity addition and checking is disabled.</p> <p>0: Even parity 1: Odd parity</p> <p>If even parity is selected, the parity bit is added to transmit data to make an even number of 1s in the transmitted character and parity bit combined. Receive data is checked to see if it has an even number of 1s in the received character and parity bit combined.</p> <p>If odd parity is selected, the parity bit is added to transmit data to make an odd number of 1s in the transmitted character and parity bit combined. Receive data is checked to see if it has an odd number of 1s in the received character and parity bit combined.</p>

Bit	Bit Name	Initial value	R/W	Description
3	STOP	0	R/W	<p>Stop Bit Length</p> <p>Selects one or two bits as the stop bit length in asynchronous mode. This setting is used only in asynchronous mode. It is ignored in clock synchronous mode because no stop bits are added.</p> <p>0: One stop bit*<sup>1</sup> 1: Two stop bits*<sup>2</sup></p> <p>When receiving, only the first stop bit is checked, regardless of the STOP bit setting. If the second stop bit is 1, it is treated as a stop bit, but if the second stop bit is 0, it is treated as the start bit of the next incoming character.</p> <p>Notes: 1. When transmitting, a single 1-bit is added at the end of each transmitted character. 2. When transmitting, two 1 bits are added at the end of each transmitted character.</p>
2	MP	0	R/W	<p>Multiprocessor Mode (only in asynchronous mode)</p> <p>Enables or disables multiprocessor mode. The PE and O/E bit settings are ignored in multiprocessor mode.</p> <p>0: Multiprocessor mode disabled 1: Multiprocessor mode enabled</p>
1, 0	CKS[1:0]	00	R/W	<p>Clock Select 1 and 0</p> <p>Select the internal clock source of the on-chip baud rate generator. Four clock sources are available. P<math>\phi</math>, P<math>\phi</math>/4, P<math>\phi</math>/16 and P<math>\phi</math>/64. For further information on the clock source, bit rate register settings, and baud rate, see section 12.3.10, Bit Rate Register (SCBRR).</p> <p>00: P<math>\phi</math> 01: P<math>\phi</math>/4 10: P<math>\phi</math>/16 11: P<math>\phi</math>/64</p> <p>Note: P<math>\phi</math>: Peripheral clock</p>

### 12.3.6 Serial Control Register (SCSCR)

SCSCR is an 8-bit register that enables or disables SCI transmission/reception and interrupt requests and selects the transmit/receive clock source. The CPU can always read and write to SCSCR.

Bit:	7	6	5	4	3	2	1	0
	TIE	RIE	TE	RE	MPIE	TEIE	CKE[1:0]	
Initial value:	0	0	0	0	0	0	0	0
R/W:	R/W	R/W	R/W	R/W	R/W	R/W	R/W	R/W

Bit	Bit Name	Initial value	R/W	Description
7	TIE	0	R/W	<p><b>Transmit Interrupt Enable</b></p> <p>Enables or disables a transmit-data-empty interrupt (TXI) to be issued when the TDRE flag in the serial status register (SCSSR) is set to 1 after serial transmit data is sent from the transmit data register (SCTDR) to the transmit shift register (SCTSR).</p> <p>TXI can be canceled by clearing the TDRE flag to 0 after reading TDRE = 1 or by clearing the TIE bit to 0.</p> <p>0: Transmit-data-empty interrupt request (TXI) is disabled</p> <p>1: Transmit-data-empty interrupt request (TXI) is enabled</p>
6	RIE	0	R/W	<p><b>Receive Interrupt Enable</b></p> <p>Enables or disables a receive-data-full interrupt (RXI) and a receive error interrupt (ERI) to be issued when the RDRF flag in SCSSR is set to 1 after the serial data received is transferred from the receive shift register (SCRSR) to the receive data register (SCRDR).</p> <p>RXI can be canceled by clearing the RDRF flag after reading RDRF = 1. ERI can be canceled by clearing the FER, PER, or ORER flag to 0 after reading 1 from the flag. Both RXI and ERI can also be canceled by clearing the RIE bit to 0.</p> <p>0: Receive-data-full interrupt (RXI) and receive-error interrupt (ERI) requests are disabled</p> <p>1: Receive-data-full interrupt (RXI) and receive-error interrupt (ERI) requests are enabled</p>

Bit	Bit Name	Initial value	R/W	Description
5	TE	0	R/W	<p>Transmit Enable</p> <p>Enables or disables the SCI serial transmitter.</p> <p>0: Transmitter disabled*<sup>1</sup></p> <p>1: Transmitter enabled*<sup>2</sup></p> <p>Notes: 1. The TDRE flag in SCSSR is fixed at 1.</p> <p>2. Serial transmission starts after writing transmit data into SCTDR and clearing the TDRE flag in SCSSR to 0 while the transmitter is enabled. Select the transmit format in the serial mode register (SCSMR) before setting TE to 1.</p>
4	RE	0	R/W	<p>Receive Enable</p> <p>Enables or disables the SCI serial receiver.</p> <p>0: Receiver disabled*<sup>1</sup></p> <p>1: Receiver enabled*<sup>2</sup></p> <p>Notes: 1. Clearing RE to 0 does not affect the receive flags (RDRF, FER, PER, and ORER). These flags retain their previous values.</p> <p>2. Serial reception starts when a start bit is detected in asynchronous mode, or synchronous clock input is detected in clock synchronous mode. Select the receive format in SCSMR before setting RE to 1.</p>
3	MPIE	0	R/W	<p>Multiprocessor Interrupt Enable (only when MP = 1 in SCSMR in asynchronous mode)</p> <p>When this bit is set to 1, receive data in which the multiprocessor bit is 0 is skipped and setting of the RDRF, FER, and ORER status flags in SCSSR is prohibited. On receiving data in which the multiprocessor bit is 1, this bit is automatically cleared to 0 and normal receiving operation is resumed. For details, see section 12.4.4, Multiprocessor Communication Function.</p>



Bit	Bit Name	Initial value	R/W	Description
2	TEIE	0	R/W	<p>Transmit End Interrupt Enable</p> <p>Enables or disables a transmit end interrupt (TEI) to be issued when no valid transmit data is found in SCTDR during MSB data transmission.</p> <p>TEI can be canceled by clearing the TEND flag to 0 (by clearing the TDRE flag in SCSSR to 0 after reading TDRE = 1) or by clearing the TEIE bit to 0.</p> <p>0: Transmit end interrupt request (TEI) is disabled 1: Transmit end interrupt request (TEI) is enabled</p>
1, 0	CKE[1:0]	00	R/W	<p>Clock Enable 1 and 0</p> <p>Select the SCI clock source and enable or disable clock output from the SCK pin. Depending on the combination of CKE1 and CKE0, the SCK pin can be used for serial clock output or serial clock input.</p> <p>When selecting the clock output in clock synchronous mode, set the C/A bit in SCSMR to 1 and then set bits CKE1 and CKE0. For details on clock source selection, see table 12.14 in section 12.4, Operation.</p> <ul style="list-style-type: none"> <li>Asynchronous mode</li> </ul> <p>00: Internal clock, SCK pin used for input pin (The input signal is ignored.) 01: Internal clock, SCK pin used for clock output*<sup>1</sup> 10: External clock, SCK pin used for clock input*<sup>2</sup> 11: External clock, SCK pin used for clock input*<sup>2</sup></p> <p>Clock synchronous mode</p> <p>00: Internal clock, SCK pin used for synchronous clock output 01: Internal clock, SCK pin used for synchronous clock output 10: External clock, SCK pin used for synchronous clock input 11: External clock, SCK pin used for synchronous clock input</p> <p>Notes: 1. The output clock frequency is 16 times the bit rate. 2. The input clock frequency is 16 times the bit rate.</p>

### 12.3.7 Serial Status Register (SCSSR)

SCSSR is an 8-bit register that contains status flags to indicate the SCI operating state.

The CPU can always read and write to SCSSR, but cannot write 1 to status flags TDRE, RDRF, ORER, PER, and FER. These flags can be cleared to 0 only after 1 is read from the flags. The TEND flag is a read-only bit and cannot be modified.

Bit:	7	6	5	4	3	2	1	0
	TDRE	RDRF	ORER	FER	PER	TEND	MPB	MPBT
Initial value:	1	0	0	0	0	1	0	0
R/W:	R/(W)*	R/(W)*	R/(W)*	R/(W)*	R/(W)*	R	R	R/W

Note: \* Writing 0 to this bit after reading it as 1 clears the flag and is the only allowed way.

Bit	Bit Name	Initial value	R/W	Description
7	TDRE	1	R/(W)*	<p>Transmit Data Register Empty</p> <p>Indicates whether data has been transferred from the transmit data register (SCTDR) to the transmit shift register (SCTSR) and SCTDR has become ready to be written with next serial transmit data.</p> <p>0: Indicates that SCTDR holds valid transmit data [Clearing condition]</p> <ul style="list-style-type: none"> <li>• When 0 is written to TDRE after reading TDRE = 1</li> </ul> <p>1: Indicates that SCTDR does not hold valid transmit data [Setting conditions]</p> <ul style="list-style-type: none"> <li>• By a power-on reset or in standby mode</li> <li>• When the TE bit in SCSCR is 0</li> <li>• When data is transferred from SCTDR to SCTSR and data can be written to SCTDR</li> </ul>

Bit	Bit Name	Initial value	R/W	Description
6	RDRF	0	R/(W)*	<p>Receive Data Register Full</p> <p>Indicates that the received data is stored in the receive data register (SCRDR).</p> <p>0: Indicates that valid received data is not stored in SCRDR</p> <p>[Clearing conditions]</p> <ul style="list-style-type: none"> <li>• By a power-on reset or in standby mode</li> <li>• When 0 is written to RDRF after reading RDRF = 1</li> </ul> <p>1: Indicates that valid received data is stored in SCRDR</p> <p>[Setting condition]</p> <ul style="list-style-type: none"> <li>• When serial reception ends normally and receive data is transferred from SCRSR to SCRDR</li> </ul> <p>Note: SCRDR and the RDRF flag are not affected and retain their previous states even if an error is detected during data reception or if the RE bit in the serial control register (SCSCR) is cleared to 0. If reception of the next data is completed while the RDRF flag is still set to 1, an overrun error will occur and the received data will be lost.</p>

---

Bit	Bit Name	Initial value	R/W	Description
5	ORER	0	R/(W)*	<p>Overrun Error</p> <p>Indicates that an overrun error occurred during reception, causing abnormal termination.</p> <p>0: Indicates that reception is in progress or was completed successfully*<sup>1</sup></p> <p>[Clearing conditions]</p> <ul style="list-style-type: none"><li>• By a power-on reset or in standby mode</li><li>• When 0 is written to ORER after reading ORER = 1</li></ul> <p>1: Indicates that an overrun error occurred during reception*<sup>2</sup></p> <p>[Setting condition]</p> <ul style="list-style-type: none"><li>• When the next serial reception is completed while RDRF = 1</li></ul> <p>Notes: 1. The ORER flag is not affected and retains its previous value when the RE bit in SCSCR is cleared to 0.</p> <p>2. The receive data prior to the overrun error is retained in SCRDR, and the data received subsequently is lost. Subsequent serial reception cannot be continued while the ORER flag is set to 1.</p>

---

Bit	Bit Name	Initial value	R/W	Description
4	FER	0	R/(W)*	<p>Framing Error</p> <p>Indicates that a framing error occurred during data reception in asynchronous mode, causing abnormal termination.</p> <p>0: Indicates that reception is in progress or was completed successfully*<sup>1</sup></p> <p>[Clearing conditions]</p> <ul style="list-style-type: none"> <li>• By a power-on reset or in standby mode</li> <li>• When 0 is written to FER after reading FER = 1</li> </ul> <p>1: Indicates that a framing error occurred during reception</p> <p>[Setting condition]</p> <ul style="list-style-type: none"> <li>• When the SCI finds that the stop bit at the end of the received data is 0 after completing reception*<sup>2</sup></li> </ul> <p>Notes: 1. The FER flag is not affected and retains its previous value when the RE bit in SCSCR is cleared to 0.</p> <p>2. In 2-stop-bit mode, only the first stop bit is checked for a value to 1; the second stop bit is not checked. If a framing error occurs, the receive data is transferred to SCRDR but the RDRF flag is not set. Subsequent serial reception cannot be continued while the FER flag is set to 1.</p>

Bit	Bit Name	Initial value	R/W	Description
3	PER	0	R/(W)*	<p>Parity Error</p> <p>Indicates that a parity error occurred during data reception in asynchronous mode, causing abnormal termination.</p> <p>0: Indicates that reception is in progress or was completed successfully*<sup>1</sup></p> <p>[Clearing conditions]</p> <ul style="list-style-type: none"> <li>• By a power-on reset or in standby mode</li> <li>• When 0 is written to PER after reading PER = 1</li> </ul> <p>1: Indicates that a parity error occurred during reception*<sup>2</sup></p> <p>[Setting condition]</p> <ul style="list-style-type: none"> <li>• When the number of 1s in the received data and parity does not match the even or odd parity specified by the <math>O/\bar{E}</math> bit in the serial mode register (SCSMR).</li> </ul> <p>Notes: 1. The PER flag is not affected and retains its previous value when the RE bit in SCSCR is cleared to 0.</p> <p>2. If a parity error occurs, the receive data is transferred to SCRDR but the RDRF flag is not set. Subsequent serial reception cannot be continued while the PER flag is set to 1.</p>

Bit	Bit Name	Initial value	R/W	Description
2	TEND	1	R	<p>Transmit End</p> <p>Indicates that no valid data was in SCTDR during transmission of the last bit of the transmit character and transmission has ended.</p> <p>The TEND flag is read-only and cannot be modified.</p> <p>0: Indicates that transmission is in progress [Clearing condition]</p> <ul style="list-style-type: none"> <li>When 0 is written to TDRE after reading TDRE = 1</li> </ul> <p>1: Indicates that transmission has ended [Setting conditions]</p> <ul style="list-style-type: none"> <li>By a power-on reset or in standby mode</li> <li>When the TE bit in SCSCR is 0</li> <li>When TDRE = 1 during transmission of the last bit of a 1-byte serial transmit character</li> </ul>
1	MPB	0	R	<p>Multiprocessor Bit</p> <p>Stores the multiprocessor bit found in the receive data. When the RE bit in SCSCR is cleared to 0, its previous state is retained.</p>
0	MPBT	0	R/W	<p>Multiprocessor Bit Transfer</p> <p>Specifies the multiprocessor bit value to be added to the transmit frame.</p>

Note: \* Writing 0 to this bit after reading it as 1 clears the flag and is the only allowed way.

### 12.3.8 Serial Port Register (SCSPTR)

SCSPTR is an 8-bit register that controls input/output and data for the ports multiplexed with the SCI function pins. Data to be output through the TXD pin can be specified to control break of serial transfer. Through bits 3 and 2, data reading and writing through the SCK pin can be specified. Bit 7 enables or disables RXI interrupts. The CPU can always read and write to SCSPTR. When reading the value on the SCI pins, use the respective port register. For details, see section 16, I/O Ports.

Bit:	7	6	5	4	3	2	1	0
	EIO	-	-	-	SPB1IO	SPB1DT	-	SPB0DT
Initial value:	0	0	0	0	0	0	0	1
R/W:	R/W	-	-	-	R/W	R/W	-	W

Bit	Bit Name	Initial value	R/W	Description
7	EIO	0	R/W	<p>Error Interrupt Only</p> <p>Enables or disables RXI interrupts. While the EIO bit is set to 1, the SCI does not request an RXI interrupt to the CPU even if the RIE bit is set to 1.</p> <p>0: The RIE bit enables or disables RXI and ERI interrupts. While the RIE bit is 1, RXI and ERI interrupts are sent to the INTC.</p> <p>1: While the RIE bit is 1, only the ERI interrupt is sent to the INTC.</p>
6 to 4	—	All 0	—	<p>Reserved</p> <p>These bits are always read as 0. The write value should always be 0.</p>
3	SPB1IO	0	R/W	<p>Clock Port Input/Output in Serial Port</p> <p>Specifies the input/output direction of the SCK pin in the serial port. To output the data specified in the SPB1DT bit through the SCK pin as a port output pin, set the <math>\overline{C/A}</math> bit in SCSMR and the CKE1 and CKE0 bits in SCSCR to 0.</p> <p>0: Does not output the SPB1DT bit value through the SCK pin.</p> <p>1: Outputs the SPB1DT bit value through the SCK pin.</p>



Bit	Bit Name	Initial value	R/W	Description												
2	SPB1DT	0	R/W	<p>Clock Port Data in Serial Port</p> <p>Specifies the data output through the SCK pin in the serial port. Output should be enabled by the SPB1IO bit (for details, refer to the SPB1IO bit description). When output is enabled, the SPB1DT bit value is output through the SCK pin.</p> <p>0: Low level is output 1: High level is output</p>												
1	—	0	—	<p>Reserved</p> <p>This bit is always read as 0. The write value should always be 0.</p>												
0	SPB0DT	1	W	<p>Serial Port Break Data</p> <p>Controls the TXD pins together with the TE bit in SCSCR.</p> <p>However, the TXD pin function should be selected with the Pin Function Controller (PFC).</p> <p>This bit is write-only bit. Undefined value is read.</p> <table border="1"> <thead> <tr> <th>Setting value of TE bit in SCSCR</th> <th>Setting value of SPB0DT bit</th> <th>TXD pin state</th> </tr> </thead> <tbody> <tr> <td>0</td> <td>0</td> <td>Low output</td> </tr> <tr> <td>0</td> <td>1</td> <td>High output (initial state)</td> </tr> <tr> <td>1</td> <td>*</td> <td>Transmit data output in accord with serial core logic.</td> </tr> </tbody> </table> <p>Note: * Don't care</p>	Setting value of TE bit in SCSCR	Setting value of SPB0DT bit	TXD pin state	0	0	Low output	0	1	High output (initial state)	1	*	Transmit data output in accord with serial core logic.
Setting value of TE bit in SCSCR	Setting value of SPB0DT bit	TXD pin state														
0	0	Low output														
0	1	High output (initial state)														
1	*	Transmit data output in accord with serial core logic.														

### 12.3.9 Serial Direction Control Register (SCSDCR)

The DIR bit in the serial direction control register (SCSDCR) selects LSB-first or MSB-first transfer. With an 8-bit data length, LSB-first/MSB-first selection is available regardless of the communication mode.

Bit:	7	6	5	4	3	2	1	0
	-	-	-	-	DIR	-	-	-
Initial value:	1	1	1	1	0	0	1	0
R/W:	R	R	R	R	R/W	R	R	R

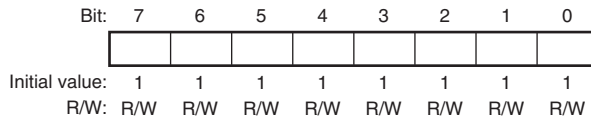
Bit	Bit Name	Initial Value	R/W	Description
7 to 4	—	All 1	R	Reserved  These bits are always read as 1. The write value should always be 1.
3	DIR	0	R/W	Data Transfer Direction  Selects the serial/parallel conversion format. Valid for an 8-bit transmit/receive format.  0: SCTDR contents are transmitted in LSB-first order Receive data is stored in SCRDR in LSB-first  1: SCTDR contents are transmitted in MSB-first order Receive data is stored in SCRDR in MSB-first
2	—	0	R	Reserved  This bit is always read as 0. The write value should always be 0.
1	—	1	R	Reserved  This bit is always read as 1. The write value should always be 1.
0	—	0	R	Reserved  This bit is always read as 0. The write value should always be 0.

### 12.3.10 Bit Rate Register (SCBRR)

SCBRR is an 8-bit register that, together with the baud rate generator clock source selected by the CKS1 and CKS0 bits in the serial mode register (SCSMR), determines the serial transmit/receive bit rate.

The CPU can always read and write to SCBRR.

The SCBRR setting is calculated as follows:



- Asynchronous mode:

$$N = \frac{P\phi}{64 \times 2^{2n-1} \times B} \times 10^6 - 1$$

- Clock synchronous mode:

$$N = \frac{P\phi}{8 \times 2^{2n-1} \times B} \times 10^6 - 1$$

B: Bit rate (bits/s)

N: SCBRR setting for baud rate generator ( $0 \leq N \leq 255$ )

(The setting value should satisfy the electrical characteristics.)

$P\phi$ : Operating frequency for peripheral modules (MHz)

n: Baud rate generator clock source ( $n = 0, 1, 2, 3$ ) (for the clock sources and values of n, see table 12.3.)

**Table 12.3 SCSMR Settings**

n	Clock Source	SCSMR Settings	
		CKS1	CKS0
0	P $\phi$	0	0
1	P $\phi$ /4	0	1
2	P $\phi$ /16	1	0
3	P $\phi$ /64	1	1

Note: The bit rate error in asynchronous is given by the following formula:

$$\text{Error (\%)} = \left\{ \frac{P\phi \times 10^6}{(N + 1) \times B \times 64 \times 2^{2n-1}} - 1 \right\} \times 100$$

Tables 12.4 to 12.6 show examples of SCBRR settings in asynchronous mode, and tables 12.7 to 12.9 show examples of SCBRR settings in clock synchronous mode.

**Table 12.4 Bit Rates and SCBRR Settings in Asynchronous Mode (1)**

Bit Rate (bits/s)	P $\phi$ (MHz)																	
	10			12			14			16			18			20		
	n	N	Error (%)	n	N	Error (%)	n	N	Error (%)	n	N	Error (%)	n	N	Error (%)	n	N	Error (%)
110	2	177	-0.25	2	212	0.03	2	248	-0.17	3	70	0.03	3	79	-0.12	3	88	-0.25
150	2	129	0.16	2	155	0.16	2	181	0.16	2	207	0.16	2	233	0.16	3	64	0.16
300	2	64	0.16	2	77	0.16	2	90	0.16	2	103	0.16	2	116	0.16	2	129	0.16
600	1	129	0.16	1	155	0.16	1	181	0.16	1	207	0.16	1	233	0.16	2	64	0.16
1200	1	64	0.16	1	77	0.16	1	90	0.16	1	103	0.16	1	116	0.16	1	129	0.16
2400	0	129	0.16	0	155	0.16	0	181	0.16	0	207	0.16	0	233	0.16	1	64	0.16
4800	0	64	0.16	0	77	0.16	0	90	0.16	0	103	0.16	0	116	0.16	0	129	0.16
9600	0	32	-1.36	0	38	0.16	0	45	-0.93	0	51	0.16	0	58	-0.69	0	64	0.16
14400	0	21	-1.36	0	25	0.16	0	29	1.27	0	34	-0.79	0	38	0.16	0	42	0.94
19200	0	15	1.73	0	19	-2.34	0	22	-0.93	0	25	0.16	0	28	1.02	0	32	-1.36
28800	0	10	-1.36	0	12	0.16	0	14	1.27	0	16	2.12	0	19	-2.34	0	21	-1.36
31250	0	9	0.00	0	11	0.00	0	13	0.00	0	15	0.00	0	17	0.00	0	19	0.00
38400	0	7	1.73	0	9	-2.34	0	10	3.57	0	12	0.16	0	14	-2.34	0	15	1.73

**Table 12.5 Bit Rates and SCBRR Settings in Asynchronous Mode (2)**

Bit Rate (bits/s)	$P\phi$ (MHz)																	
	22			24			26			28			30			32		
	n	N	Error (%)	n	N	Error (%)	n	N	Error (%)	n	N	Error (%)	n	N	Error (%)	n	N	Error (%)
110	3	97	-0.35	3	106	-0.44	3	114	0.36	3	123	0.23	3	132	0.13	3	141	0.03
150	3	71	-0.54	3	77	0.16	3	84	-0.43	3	90	0.16	3	97	-0.35	3	103	0.16
300	2	142	0.16	2	155	0.16	2	168	0.16	2	181	0.16	2	194	0.16	2	207	0.16
600	2	71	-0.54	2	77	0.16	2	84	-0.43	2	90	0.16	2	97	-0.35	2	103	0.16
1200	1	142	0.16	1	155	0.16	1	168	0.16	1	181	0.16	1	194	0.16	1	207	0.16
2400	1	71	-0.54	1	77	0.16	1	84	-0.43	1	90	0.16	1	97	-0.35	1	103	0.16
4800	0	142	0.16	0	155	0.16	0	168	0.16	0	181	0.16	0	194	0.16	0	207	0.16
9600	0	71	-0.54	0	77	0.16	0	84	-0.43	0	90	0.16	0	97	-0.35	0	103	0.16
14400	0	47	-0.54	0	51	0.16	0	55	0.76	0	60	-0.39	0	64	0.16	0	68	0.64
19200	0	35	-0.54	0	38	0.16	0	41	0.76	0	45	-0.93	0	48	-0.35	0	51	0.16
28800	0	23	-0.54	0	25	0.16	0	27	0.76	0	29	1.27	0	32	-1.36	0	34	-0.79
31250	0	21	0.00	0	23	0.00	0	25	0.00	0	27	0.00	0	29	0.00	0	31	0.00
38400	0	17	-0.54	0	19	-2.34	0	20	0.76	0	22	-0.93	0	23	1.73	0	25	0.16

**Table 12.6 Bit Rates and SCBRR Settings in Asynchronous Mode (3)**

Bit Rate (bits/s)	P $\phi$ (MHz)											
	34			36			38			40		
	n	N	Error (%)	n	N	Error (%)	n	N	Error (%)	n	N	Error (%)
110	3	150	-0.05	3	159	-0.12	3	168	-0.19	3	177	-0.25
150	3	110	-0.29	3	116	0.16	3	123	-0.24	3	129	0.16
300	2	220	0.16	2	233	0.16	2	246	0.16	3	64	0.16
600	2	110	-0.29	2	116	0.16	2	123	-0.24	2	129	0.16
1200	1	220	0.16	1	233	0.16	1	246	0.16	2	64	0.16
2400	1	110	-0.29	1	116	0.16	1	123	-0.24	1	129	0.16
4800	0	220	0.16	0	233	0.16	0	246	0.16	1	64	0.16
9600	0	110	-0.29	0	116	0.16	0	123	-0.24	0	129	0.16
14400	0	73	-0.29	0	77	0.16	0	81	0.57	0	86	-0.22
19200	0	54	0.62	0	58	-0.69	0	61	-0.24	0	64	0.16
28800	0	36	-0.29	0	38	0.16	0	40	0.57	0	42	0.94
31250	0	33	0.00	0	35	0.00	0	37	0.00	0	39	0.00
38400	0	27	-1.18	0	28	1.02	0	30	-0.24	0	32	-1.36

**Table 12.7 Bit Rates and SCBRR Settings in Clock Synchronous Mode (1)**

Bit Rate (bits/s)	P $\phi$ (MHz)											
	10		12		14		16		18		20	
	n	N	n	N	n	N	n	N	n	N	n	N
250	3	155	3	187	3	218	3	249				
500	3	77	3	93	3	108	3	124	3	140	3	155
1000	2	155	2	187	2	218	2	249	3	69	3	77
2500	1	249	2	74	2	87	2	99	2	112	2	124
5000	1	124	1	149	1	174	1	199	1	224	1	249
10000	0	249	1	74	1	87	1	99	1	112	1	124
25000	0	99	0	119	0	139	0	159	0	179	0	199
50000	0	49	0	59	0	69	0	79	0	89	0	99
100000	0	24	0	29	0	34	0	39	0	44	0	49
250000	0	9	0	11	0	13	0	15	0	17	0	19
500000	0	4	0	5	0	6	0	7	0	8	0	9
1000000	—	—	0	2	—	—	0	3	—	—	0	4
2500000	0	0*	—	—	—	—	—	—	—	—	0	1
5000000			—	—	—	—	—	—	—	—	0	0*



**Table 12.8 Bit Rates and SCBRR Settings in Clock Synchronous Mode (2)**

Bit Rate (bits/s)	P $\phi$ (MHz)											
	22		24		26		28		30		32	
	n	N	n	N	n	N	n	N	n	N	n	N
250												
500	3	171	3	187	3	202	3	218	3	233	3	249
1000	3	85	3	93	3	101	3	108	3	116	3	124
2500	2	137	2	149	2	162	2	174	2	187	2	199
5000	2	68	2	74	2	80	2	87	2	93	2	99
10000	1	137	1	149	1	162	1	174	1	187	1	199
25000	0	219	0	239	1	64	1	69	1	74	1	79
50000	0	109	0	119	0	129	0	139	0	149	0	159
100000	0	54	0	59	0	64	0	69	0	74	0	79
250000	0	21	0	23	0	25	0	27	0	29	0	31
500000	0	10	0	11	0	12	0	13	0	14	0	15
1000000	—	—	0	5	—	—	0	6	—	—	0	7
2500000	—	—	—	—	—	—	—	—	0	2	—	—
5000000	—	—	—	—	—	—	—	—	—	—	—	—

**Table 12.9 Bit Rates and SCBRR Settings in Clock Synchronous Mode (3)**

Bit Rate (bits/s)	P $\phi$ (MHz)							
	34		36		38		40	
	n	N	n	N	n	N	n	N
250								
500								
1000	3	132	3	140	3	147	3	155
2500	2	212	2	224	2	237	2	249
5000	2	105	2	112	2	118	2	124
10000	1	212	1	224	1	237	1	249
25000	1	84	1	89	1	94	1	99
50000	0	169	0	179	0	189	0	199
100000	0	84	0	89	0	94	0	99
250000	0	33	0	35	0	37	0	39
500000	0	16	0	17	0	18	0	19
1000000	—	—	0	8	—	—	0	9
2500000	—	—	—	—	—	—	0	3
5000000	—	—	—	—	—	—	0	1

## [Legend]

Blank: No setting possible

—: Setting possible, but error occurs

\*: Continuous transmission/reception is disabled.

Note: Settings with an error of 1% or less are recommended.

Table 12.10 indicates the maximum bit rates in asynchronous mode when the baud rate generator is used. Tables 12.11 and 12.12 list the maximum rates for external clock input.

**Table 12.10 Maximum Bit Rates for Various Frequencies with Baud Rate Generator (Asynchronous Mode)**

P $\phi$ (MHz)	Maximum Bit Rate (bits/s)	Settings	
		n	N
10	312500	0	0
12	375000	0	0
14	437500	0	0
16	500000	0	0
18	562500	0	0
20	625000	0	0
22	687500	0	0
24	750000	0	0
26	812500	0	0
28	875000	0	0
30	937500	0	0
32	1000000	0	0
34	1062500	0	0
36	1125000	0	0
38	1187500	0	0
40	1250000	0	0

**Table 12.11 Maximum Bit Rates with External Clock Input (Asynchronous Mode)**

<b>P<math>\phi</math> (MHz)</b>	<b>External Input Clock (MHz)</b>	<b>Maximum Bit Rate (bits/s)</b>
10	2.5000	156250
12	3.0000	187500
14	3.5000	218750
16	4.0000	250000
18	4.5000	281250
20	5.0000	312500
22	5.5000	343750
24	6.0000	375000
26	6.5000	406250
28	7.0000	437500
30	7.5000	468750
32	8.0000	500000
34	8.5000	531250
36	9.0000	562500
38	9.5000	593750
40	10.0000	625000

**Table 12.12 Maximum Bit Rates with External Clock Input (Clock Synchronous Mode)**

<b>P<math>\phi</math> (MHz)</b>	<b>External Input Clock (MHz)</b>	<b>Maximum Bit Rate (bits/s)</b>
10	1.6667	1666666.7
12	2.0000	2000000.0
14	2.3333	2333333.3
16	2.6667	2666666.7
18	3.0000	3000000.0
20	3.3333	3333333.3
22	3.6667	3666666.7
24	4.0000	4000000.0
26	4.3333	4333333.3
28	4.6667	4666666.7
30	5.0000	5000000.0
32	5.3333	5333333.3
34	5.6667	5666666.7
36	6.0000	6000000.0
38	6.3333	6333333.3
40	6.6667	6666666.7

## 12.4 Operation

### 12.4.1 Overview

For serial communication, the SCI has an asynchronous mode in which characters are synchronized individually, and a clock synchronous mode in which communication is synchronized with clock pulses.

Asynchronous or clock synchronous mode is selected and the transmit format is specified in the serial mode register (SCSMR) as shown in table 12.13. The SCI clock source is selected by the combination of the  $C/\bar{A}$  bit in SCSMR and the CKE1 and CKE0 bits in the serial control register (SCSCR) as shown in table 12.14.

#### (1) Asynchronous Mode (Channels 0 to 2 in the SH7125, Channels 0 to 2 in the SH7124)

- Data length is selectable: 7 or 8 bits.
- Parity bit is selectable. So is the stop bit length (1 or 2 bits). The combination of the preceding selections constitutes the communication format and character length.
- In receiving, it is possible to detect framing errors, parity errors, overrun errors, and breaks.
- An internal or external clock can be selected as the SCI clock source.
  - When an internal clock is selected, the SCI operates using the clock supplied by the on-chip baud rate generator and can output a clock with a frequency 16 times the bit rate.
  - When an external clock is selected, the external clock input must have a frequency 16 times the bit rate. (The on-chip baud rate generator is not used.)

#### (2) Clock Synchronous Mode (Channels 0 to 2 in the SH7125, Channels 0 and 2 in the SH7124)

- The transmission/reception format has a fixed 8-bit data length.
- In receiving, it is possible to detect overrun errors.
- An internal or external clock can be selected as the SCI clock source.
  - When an internal clock is selected, the SCI operates using the on-chip baud rate generator, and outputs a serial clock signal to external devices.
  - When an external clock is selected, the SCI operates on the input serial clock. The on-chip baud rate generator is not used.

Table 12.13 SCSMR Settings and SCI Communication Formats

SCSMR Settings				SCI Communication Format				
Bit 7 C/ $\bar{A}$	Bit 6 CHR	Bit 5 PE	Bit 3 STOP	Mode	Data Length	Parity Bit	Stop Bit Length	
0	0	0	0	Asynchronous	8-bit	Not set	1 bit	
			1				2 bits	
			0				1 bit	
			1				2 bits	
		1	0	0	Clock synchronous	7-bit	Not set	1 bit
				1				2 bits
				0				1 bit
				1				2 bits
1	x	x	x	Clock synchronous	8-bit	Not set	None	

[Legend]

x: Don't care

Table 12.14 SCSMR and SCSCR Settings and SCI Clock Source Selection

SCSMR			SCSCR Settings		Clock Source	SCK Pin Function
Bit 7 C/ $\bar{A}$	Bit 1 CKE1	Bit 0 CKE0	Mode	Mode		
0	0	0	Asynchronous	Internal	SCI does not use the SCK pin. Clock with a frequency 16 times the bit rate is output.	
		1				
		0			External	Input a clock with frequency 16 times the bit rate.
		1				
1	0	0	Clock synchronous	Internal	Serial clock is output.	
		1				
		0		External	Input the serial clock.	
		1				

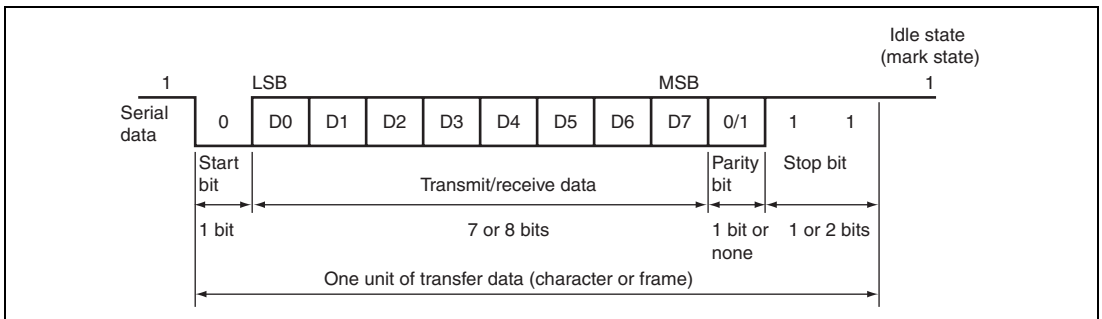
## 12.4.2 Operation in Asynchronous Mode

In asynchronous mode, each transmitted or received character begins with a start bit and ends with a stop bit. Serial communication is synchronized one character at a time.

The transmitting and receiving sections of the SCI are independent, so full duplex communication is possible. Both the transmitter and receiver have a double-buffered structure so that data can be read or written during transmission or reception, enabling continuous data transfer.

Figure 12.2 shows the general format of asynchronous serial communication. In asynchronous serial communication, the communication line is normally held in the mark (high) state. The SCI monitors the line and starts serial communication when the line goes to the space (low) state, indicating a start bit. One serial character consists of a start bit (low), data (LSB first), parity bit (high or low), and stop bit (high), in that order.

When receiving in asynchronous mode, the SCI synchronizes at the falling edge of the start bit. The SCI samples each data bit on the eighth pulse of a clock with a frequency 16 times the bit rate. Receive data is latched at the center of each bit.



**Figure 12.2 Example of Data Format in Asynchronous Communication (8-Bit Data with Parity and Two Stop Bits)**



**(1) Transmit/Receive Formats**

Table 12.15 shows the transfer formats that can be selected in asynchronous mode. Any of 12 transfer formats can be selected according to the SCSMR settings.

**Table 12.15 Serial Transfer Formats (Asynchronous Mode)**

SCSMR Settings				Serial Transfer Format and Frame Length													
CHR	PE	MP	STOP	1	2	3	4	5	6	7	8	9	10	11	12		
0	0	0	0	S	8-bit data								STOP				
0	0	0	1	S	8-bit data								STOP	STOP			
0	1	0	0	S	8-bit data								P	STOP			
0	1	0	1	S	8-bit data								P	STOP	STOP		
1	0	0	0	S	7-bit data							STOP					
1	0	0	1	S	7-bit data							STOP	STOP				
1	1	0	0	S	7-bit data							P	STOP				
1	1	0	1	S	7-bit data							P	STOP	STOP			
0	x	1	0	S	8-bit data								MPB	STOP			
0	x	1	1	S	8-bit data								MPB	STOP	STOP		
1	x	1	0	S	7-bit data							MPB	STOP				
1	x	1	1	S	7-bit data							MPB	STOP	STOP			

[Legend]

S: Start bit

STOP: Stop bit

P: Parity bit

MPB: Multiprocessor bit

x: Don't care

## (2) Clock

An internal clock generated by the on-chip baud rate generator or an external clock input from the SCK pin can be selected as the SCI transmit/receive clock. The clock source is selected by the  $C/\bar{A}$  bit in the serial mode register (SCSMR) and bits CKE1 and CKE0 in the serial control register (SCSCR) (table 12.14).

When an external clock is input at the SCK pin, it must have a frequency equal to 16 times the desired bit rate.

When the SCI operates on an internal clock, it can output a clock signal at the SCK pin. The frequency of this output clock is equal to 16 times the desired bit rate.

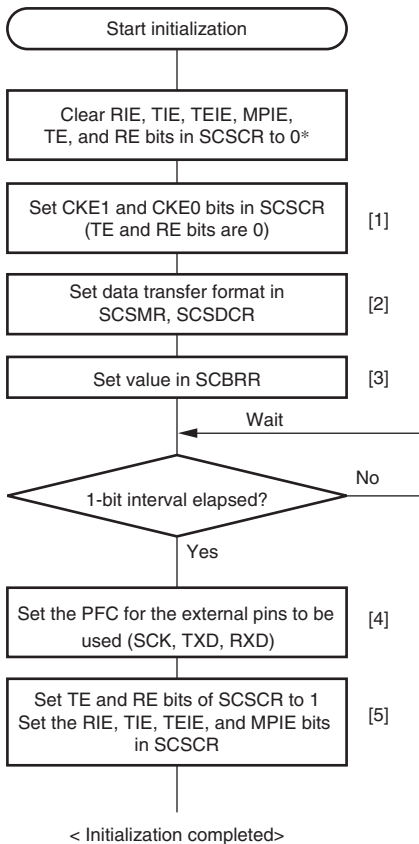
## (3) Transmitting and Receiving Data

### SCI Initialization (Asynchronous Mode):

Before transmitting or receiving, clear the TE and RE bits to 0 in the serial control register (SCSCR), then initialize the SCI as follows.

When changing the operation mode or the communication format, always clear the TE and RE bits to 0 before following the procedure given below. Clearing the TE bit to 0 sets the TDRE flag to 1 and initializes the transmit shift register (SCTSR). Clearing the RE bit to 0, however, does not initialize the RDRF, PER, FER, and ORER flags or receives data register (SCRDR), which retains their previous contents.

When an external clock is used, the clock should not be stopped during initialization or subsequent operation. SCI operation becomes unreliable if the clock is stopped.



- [1] Set the clock selection in SCSCR.
- [2] Set the data transfer format in SCSMR and SCSDCR.
- [3] Write a value corresponding to the bit rate to SCBRR. Not necessary if an external clock is used.
- [4] Set PFC of the external pin used. Set RXD input during receiving and TXD output during transmitting. Set SCK input/output according to contents set by CKE1 and CKE0. When CKE1 and CKE0 are 0 in asynchronous mode, setting the SCK pin is unnecessary. Outputting clocks from the SCK pin starts at synchronous clock output setting.
- [5] Set the TE bit or RE bit in SCSCR to 1.\* Also make settings of the RIE, TIE, TEIE, and MPIE bits. At this time, the TXD, RXD, and SCK pins are ready to be used. The TXD pin is in a mark state during transmitting, and RXD pin is in an idle state for waiting the start bit during receiving.

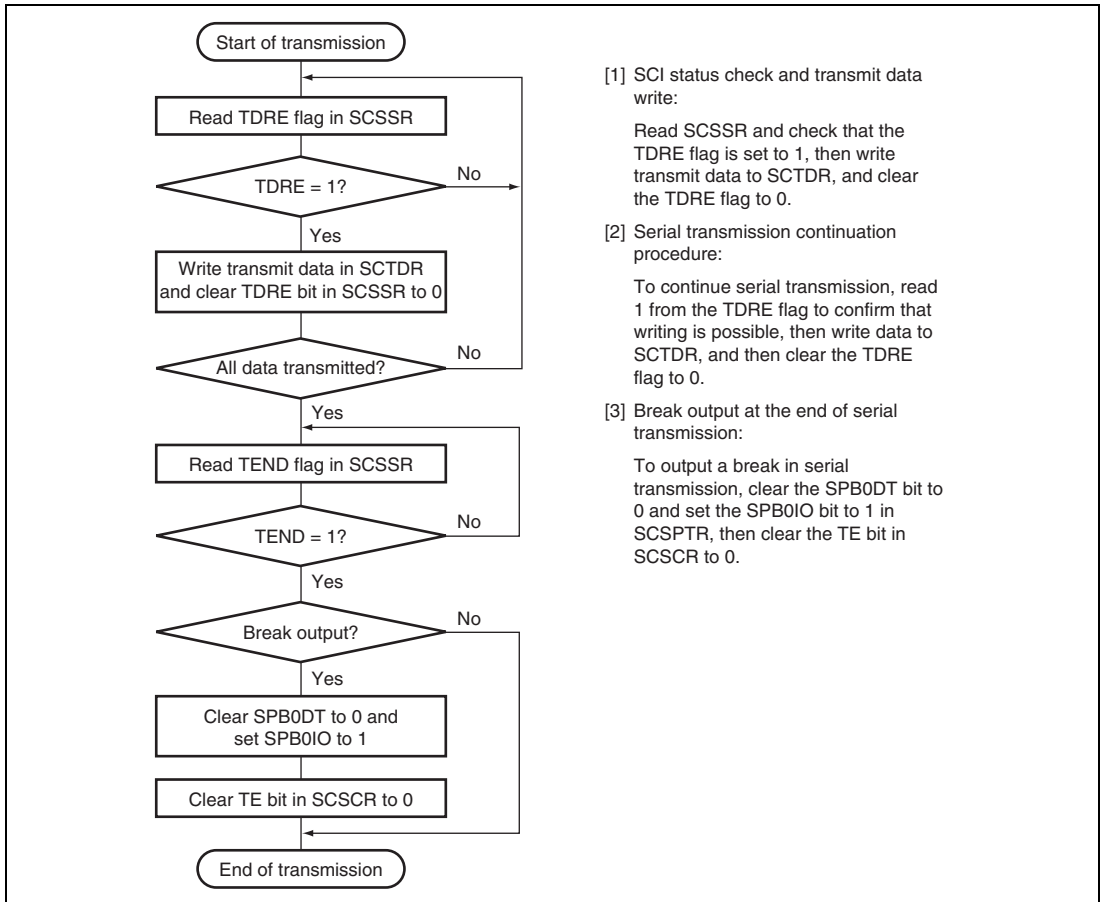
Note : \* In simultaneous transmit/receive operation, the TE and RE bits must be cleared to 0 or set to 1 simultaneously.

**Figure 12.3 Sample Flowchart for SCI Initialization**

**Transmitting Serial Data (Asynchronous Mode):**

Figure 12.4 shows a sample flowchart for serial transmission.

Use the following procedure for serial data transmission after enabling the SCI for transmission.



**Figure 12.4 Sample Flowchart for Transmitting Serial Data**

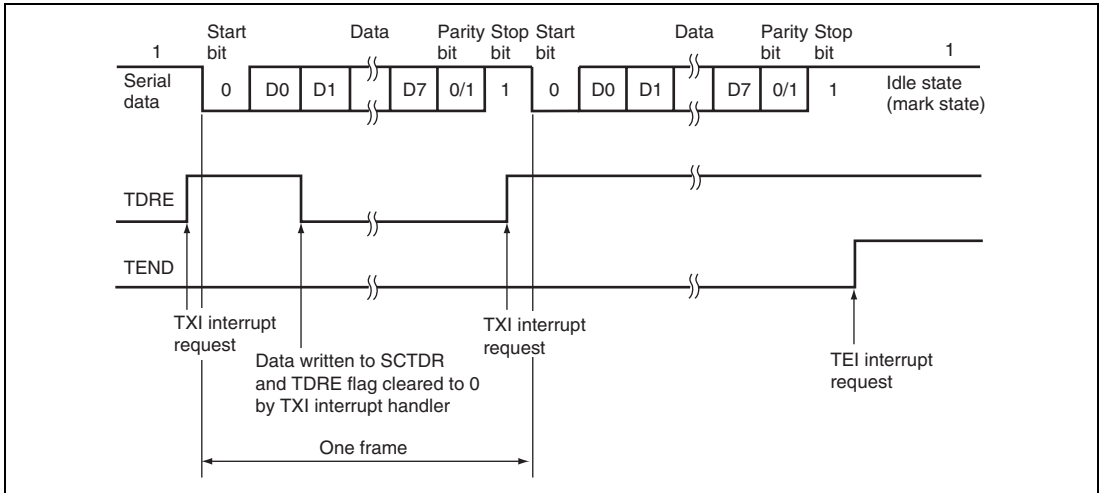
In serial transmission, the SCI operates as described below.

1. The SCI monitors the TDRE flag in the serial status register (SCSSR). If it is cleared to 0, the SCI recognizes that data has been written to the transmit data register (SCTDR) and transfers the data from SCTDR to the transmit shift register (SCTSR).
2. After transferring data from SCTDR to SCTSR, the SCI sets the TDRE flag to 1 and starts transmission. If the TIE bit in the serial control register (SCSCR) is set to 1 at this time, a transmit-data-empty interrupt (TXI) request is generated.

The serial transmit data is sent from the TXD pin in the following order.

- A. Start bit: One-bit 0 is output.
  - B. Transmit data: 8-bit or 7-bit data is output in LSB-first order.
  - C. Parity bit or multiprocessor bit: One parity bit (even or odd parity) or one multiprocessor bit is output. (A format in which neither parity nor multiprocessor bit is output can also be selected.)
  - D. Stop bit(s): One or two 1 bits (stop bits) are output.
  - E. Mark state: 1 is output continuously until the start bit that starts the next transmission is sent.
3. The SCI checks the TDRE flag at the timing for sending the stop bit.  
If the TDRE flag is 0, the data is transferred from SCTDR to SCTSR, the stop bit is sent, and then serial transmission of the next frame is started.  
If the TDRE flag is 1, the TEND flag in SCSSR is set to 1, the stop bit is sent, and then the "mark state" is entered in which 1 is output. If the TEIE bit in SCSCR is set to 1 at this time, a TEI interrupt request is generated.

Figure 12.5 shows an example of the operation for transmission.

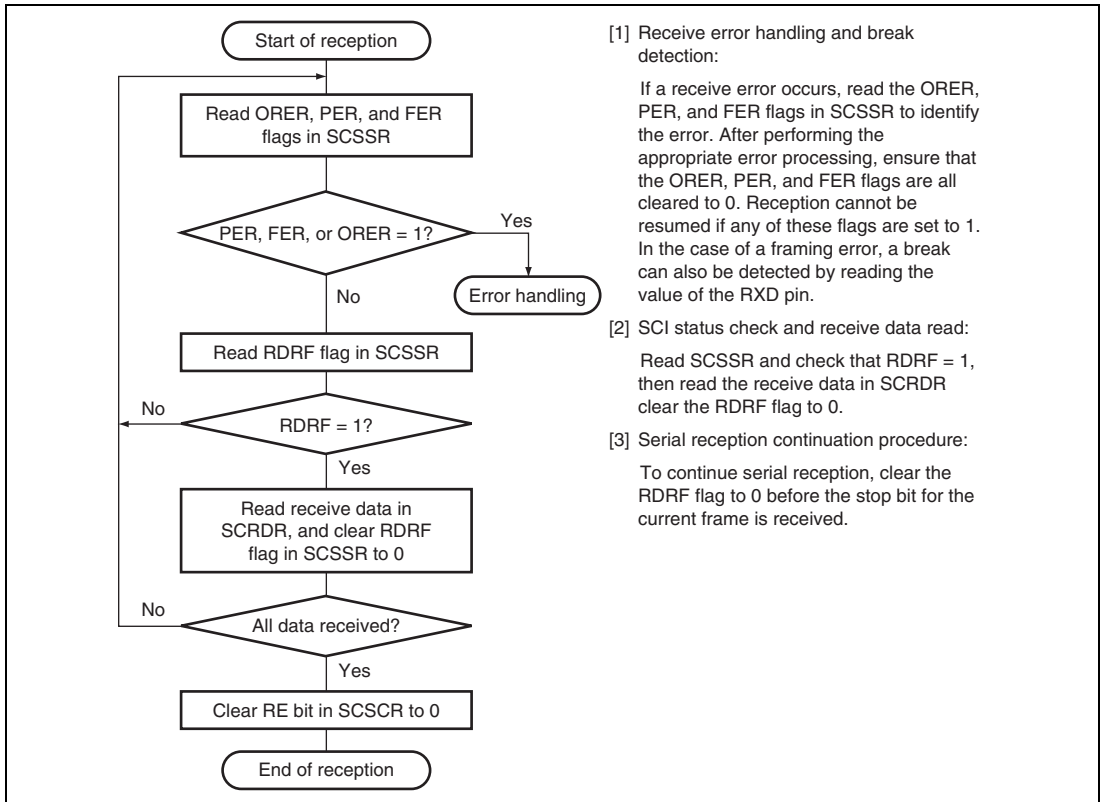


**Figure 12.5 Example of Transmission in Asynchronous Mode (8-Bit Data, Parity, One Stop Bit)**

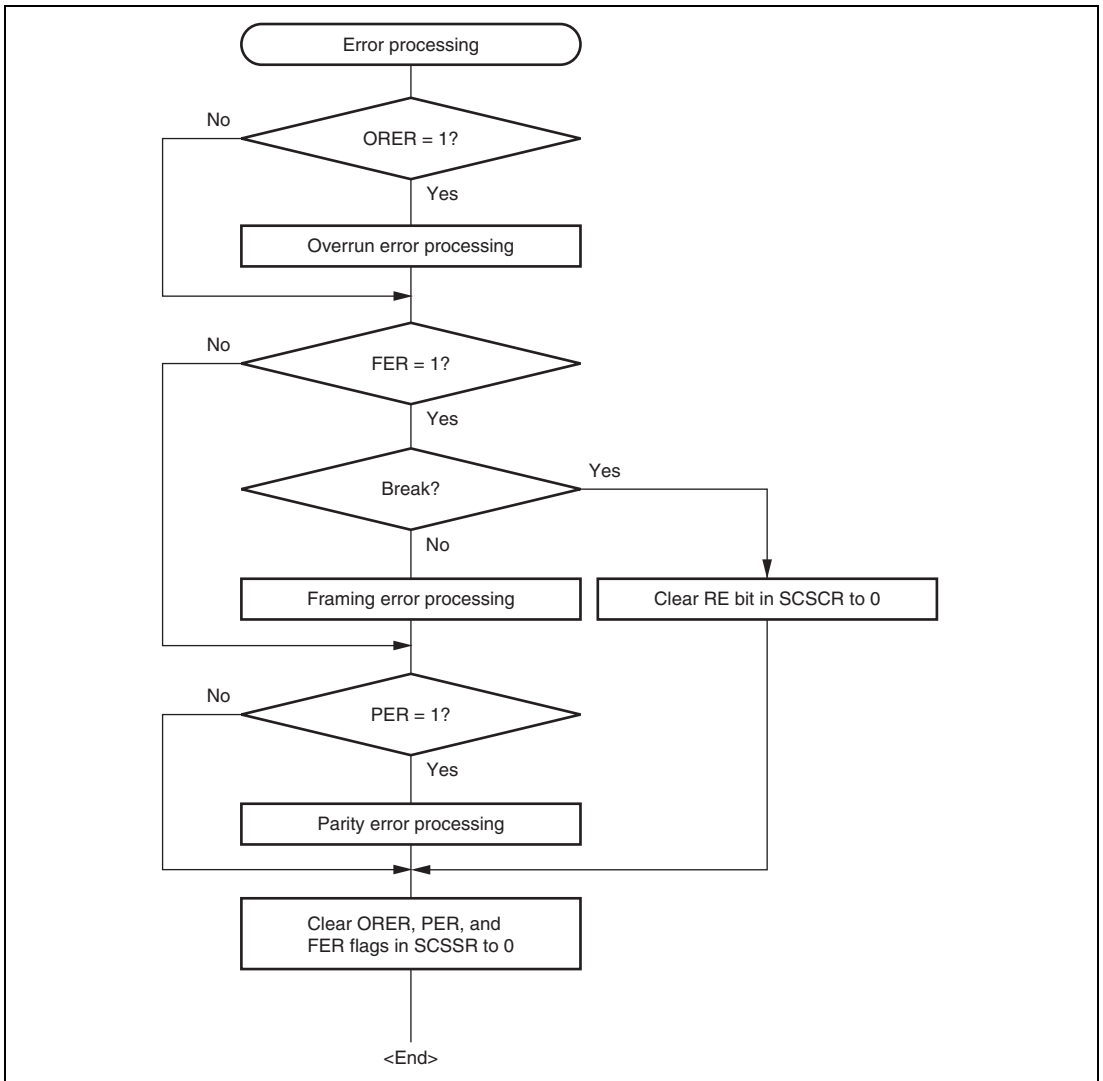
## Receiving Serial Data (Asynchronous Mode):

Figure 12.6 shows a sample flowchart for serial reception.

Use the following procedure for serial data reception after enabling the SCI for reception.



**Figure 12.6 Sample Flowchart for Receiving Serial Data**

**Figure 12.6 Sample Flowchart for Receiving Serial Data (cont)**



In serial reception, the SCI operates as described below.

1. The SCI monitors the transmission line, and if a 0 start bit is detected, performs internal synchronization and starts reception.
2. The received data is stored in SCRSR in LSB-to-MSB order.
3. The parity bit and stop bit are received.  
After receiving these bits, the SCI carries out the following checks.
  - A. Parity check: The SCI counts the number of 1s in the received data and checks whether the count matches the even or odd parity specified by the O/ $\bar{E}$  bit in the serial mode register (SCSMR).
  - B. Stop bit check: The SCI checks whether the stop bit is 1. If there are two stop bits, only the first is checked.
  - C. Status check: The SCI checks whether the RDRF flag is 0 and the received data can be transferred from the receive shift register (SCRSR) to SCRDR.

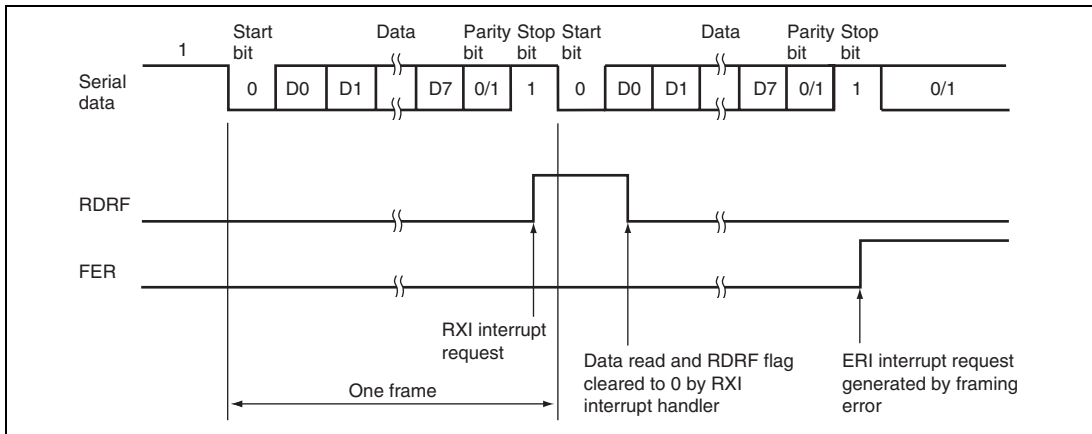
If all the above checks are passed, the RDRF flag is set to 1 and the received data is stored in SCRDR. If a receive error is detected, the SCI operates as shown in table 12.16.

Note: When a receive error occurs, subsequent reception cannot be continued. In addition, the RDRF flag will not be set to 1 after reception; be sure to clear the error flag to 0.
4. If the EIO bit in SCSPTR is cleared to 0 and the RIE bit in SCSCR is set to 1 when the RDRF flag changes to 1, a receive-data-full interrupt (RXI) request is generated. If the RIE bit in SCSCR is set to 1 when the ORER, PER, or FER flag changes to 1, a receive error interrupt (ERI) request is generated.

**Table 12.16 Receive Errors and Error Conditions**

Receive Error	Abbreviation	Error Condition	Data Transfer
Overrun error	ORER	When the next data reception is completed while the RDRF flag in SCSSR is set to 1	The received data is not transferred from SCRSR to SCRDR.
Framing error	FER	When the stop bit is 0	The received data is transferred from SCRSR to SCRDR.
Parity error	PER	When the received data does not match the even or odd parity specified in SCSMR	The received data is transferred from SCRSR to SCRDR.

Figure 12.7 shows an example of the operation for reception.



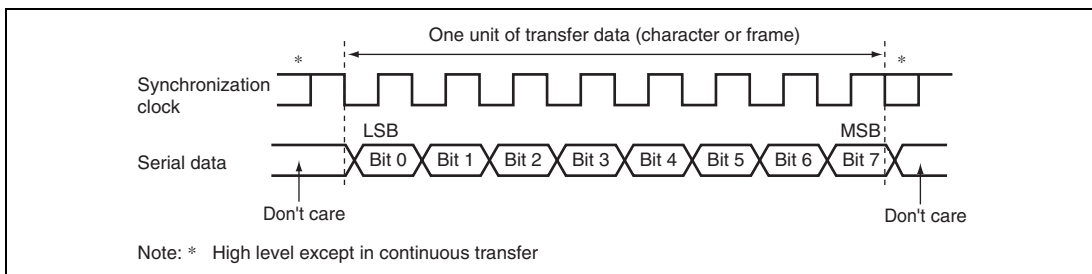
**Figure 12.7 Example of SCI Receive Operation  
(8-Bit Data, Parity, One Stop Bit)**

### 12.4.3 Clock Synchronous Mode (Channel 1 in the SH7124 is not Available)

In clock synchronous mode, the SCIF transmits and receives data in synchronization with clock pulses. This mode is suitable for high-speed serial communication.

The SCI transmitter and receiver are independent, so full-duplex communication is possible while sharing the same clock. Both the transmitter and receiver have a double-buffered structure so that data can be read or written during transmission or reception, enabling continuous data transfer.

Figure 12.8 shows the general format in clock synchronous serial communication.



**Figure 12.8 Data Format in Clock Synchronous Communication**

In clock synchronous serial communication, each data bit is output on the communication line from one falling edge of the serial clock to the next. Data is guaranteed valid at the rising edge of the serial clock. In each character, the serial data bits are transmitted in order from the LSB (first) to the MSB (last). After output of the MSB, the communication line remains in the state of the MSB. In clock synchronous mode, the SCI transmits or receives data by synchronizing with the rising edge of the serial clock.

### **(1) Communication Format**

The data length is fixed at eight bits. No parity bit can be added.

### **(2) Clock**

An internal clock generated by the on-chip baud rate generator or an external clock input from the SCK pin can be selected as the SCI transmit/receive clock. For selection of the SCI clock source, see table 12.14.

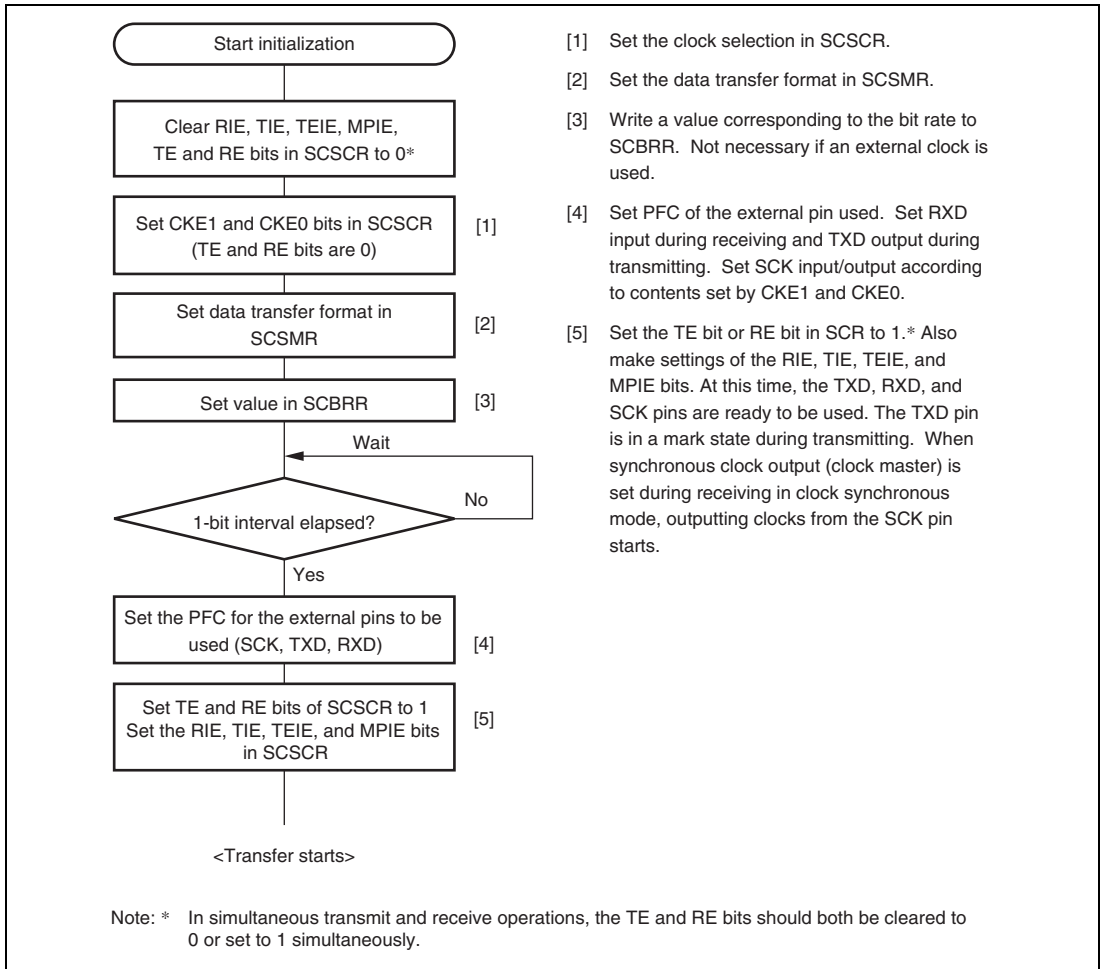
When the SCI operates on an internal clock, it outputs the clock signal at the SCK pin. Eight clock pulses are output per transmitted or received character. When the SCI is not transmitting or receiving, the clock signal remains in the high state. When only reception is performed, the synchronous clock continues to be output until an overrun error occurs or the RE bit is cleared to 0. For the reception of n characters, select the external clock as the clock source. If the internal clock has to be used, set RE and TE to 1, then transmit n characters of dummy data at the same time as receiving the n characters of data.

### **(3) Transmitting and Receiving Data**

#### **SCI Initialization (Clock Synchronous Mode):**

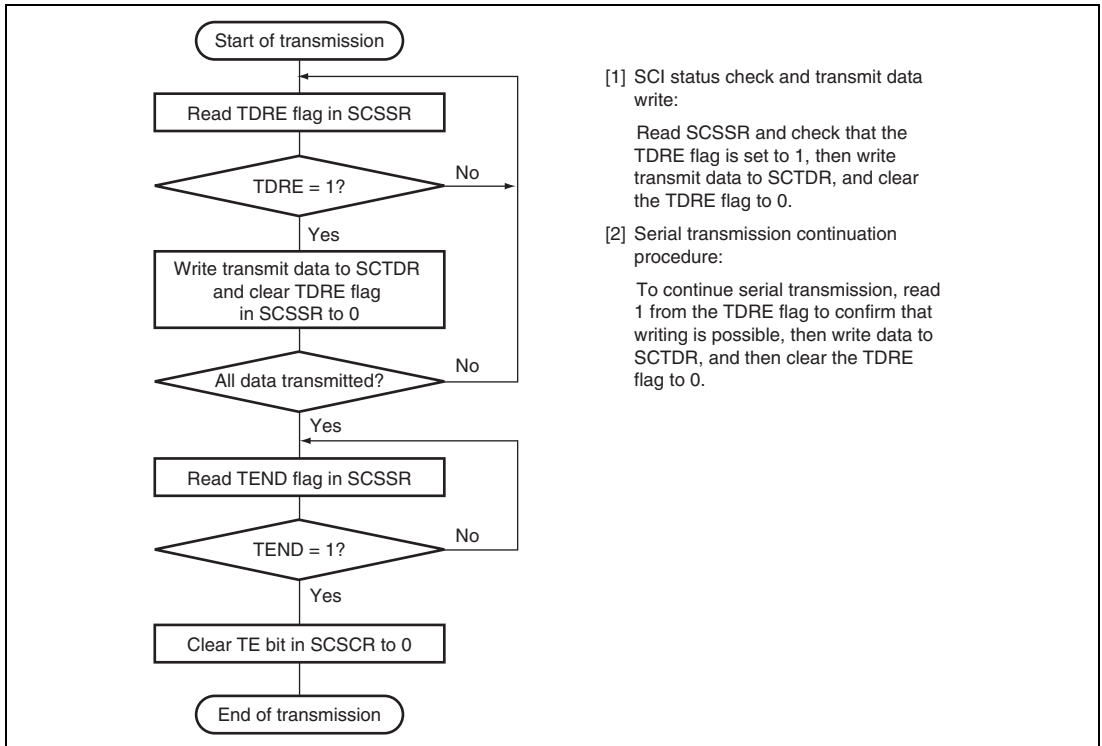
Before transmitting, receiving, or changing the mode or communication format, the software must clear the TE and RE bits to 0 in the serial control register (SCSCR), then initialize the SCI. Clearing TE to 0 sets the TDRE flag to 1 and initializes the transmit shift register (SCTSR). Clearing RE to 0, however, does not initialize the RDRF, PER, FER, and ORER flags and receive data register (SCRDR), which retain their previous contents.

Figure 12.9 shows a sample flowchart for initializing the SCI.

**Figure 12.9 Sample Flowchart for SCI Initialization**

**Transmitting Serial Data (Clock Synchronous Mode):** Figure 12.10 shows a sample flowchart for transmitting serial data.

Use the following procedure for serial data transmission after enabling the SCI for transmission.

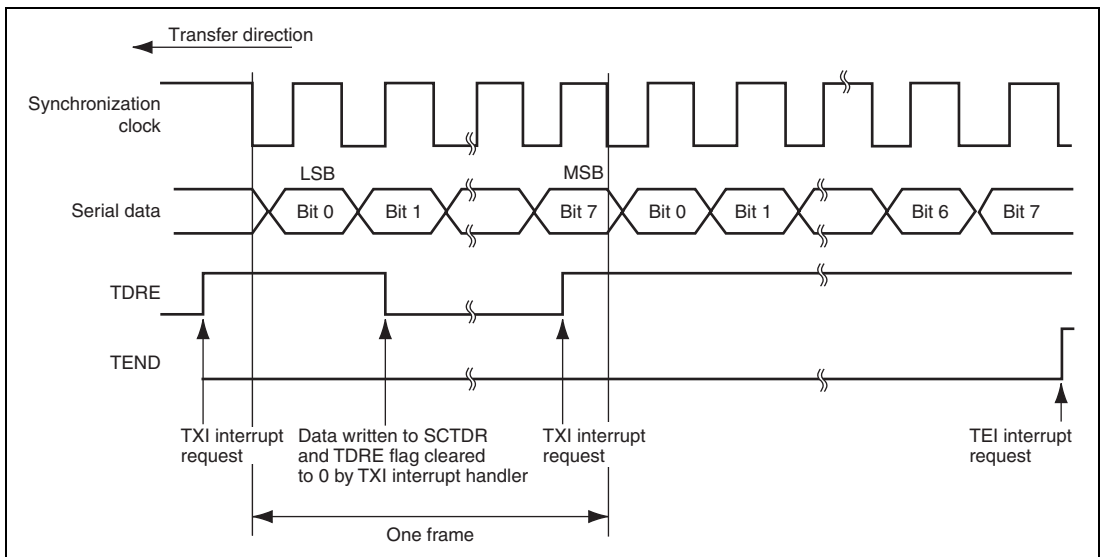


**Figure 12.10 Sample Flowchart for Transmitting Serial Data**

### In transmitting serial data, the SCI operates as follows:

1. The SCI monitors the TDRE flag in the serial status register (SCSSR). If it is cleared to 0, the SCI recognizes that data has been written to the transmit data register (SCTDR) and transfers the data from SCTDR to the transmit shift register (SCTSR).
2. After transferring data from SCTDR to SCTSR, the SCI sets the TDRE flag to 1 and starts transmission. If the transmit-data-empty interrupt enable bit (TIE) in the serial control register (SCSCR) is set to 1 at this time, a transmit-data-empty interrupt (TXI) request is generated. If clock output mode is selected, the SCI outputs eight synchronous clock pulses. If an external clock source is selected, the SCI outputs data in synchronization with the input clock. Data is output from the TXD pin in order from the LSB (bit 0) to the MSB (bit 7).
3. The SCI checks the TDRE flag at the timing for sending the MSB (bit 7). If the TDRE flag is 0, the data is transferred from SCTDR to SCTSR and serial transmission of the next frame is started. If the TDRE flag is 1, the TEND flag in SCSSR is set to 1, the MSB (bit 7) is sent, and then the TXD pin holds the states. If the TEIE bit in SCSCR is set to 1 at this time, a TEI interrupt request is generated.
4. After the end of serial transmission, the SCK pin is held in the high state.

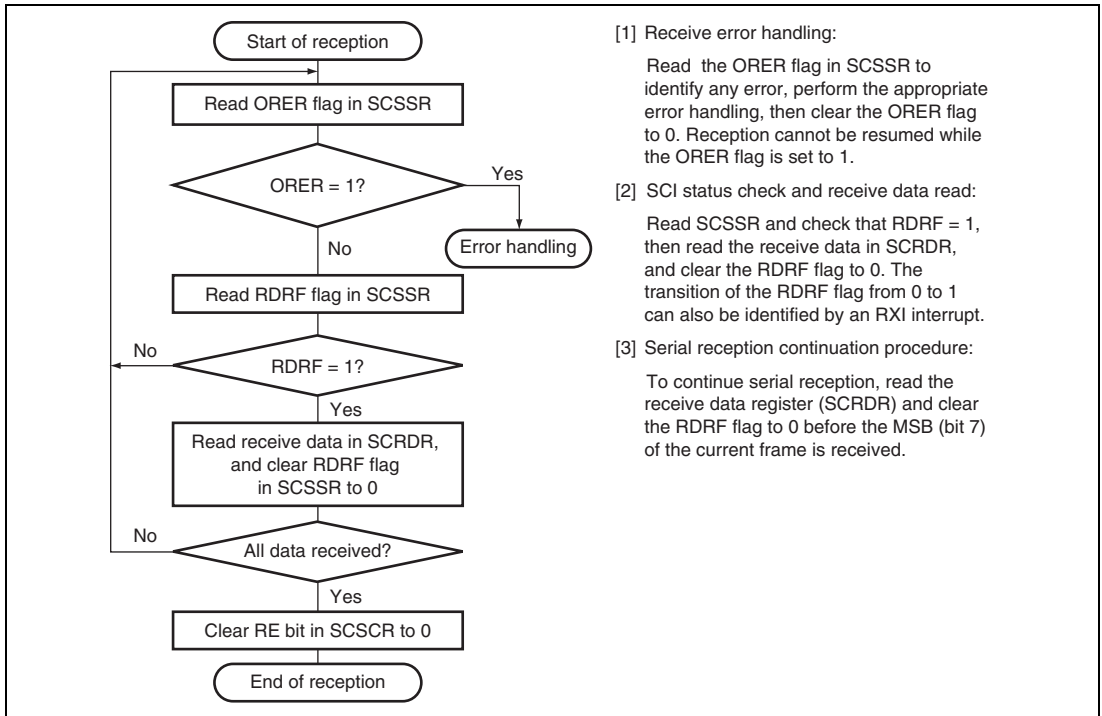
Figure 12.11 shows an example of SCI transmit operation.



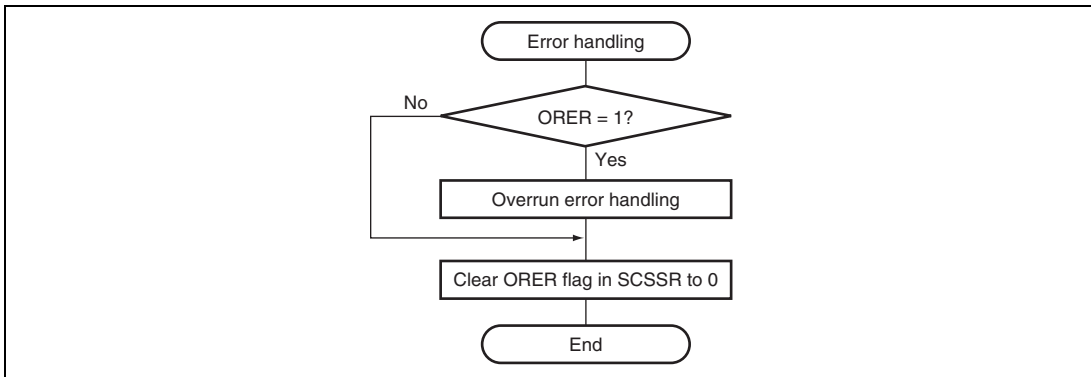
**Figure 12.11 Example of SCI Transmit Operation**

**Receiving Serial Data (Clock Synchronous Mode):** Figure 12.12 shows a sample flowchart for receiving serial data. Use the following procedure for serial data reception after enabling the SCIF for reception.

When switching from asynchronous mode to clock synchronous mode, make sure that the ORER, PER, and FER flags are all cleared to 0. If the FER or PER flag is set to 1, the RDRF flag will not be set and data reception cannot be started.



**Figure 12.12 Sample Flowchart for Receiving Serial Data (1)**



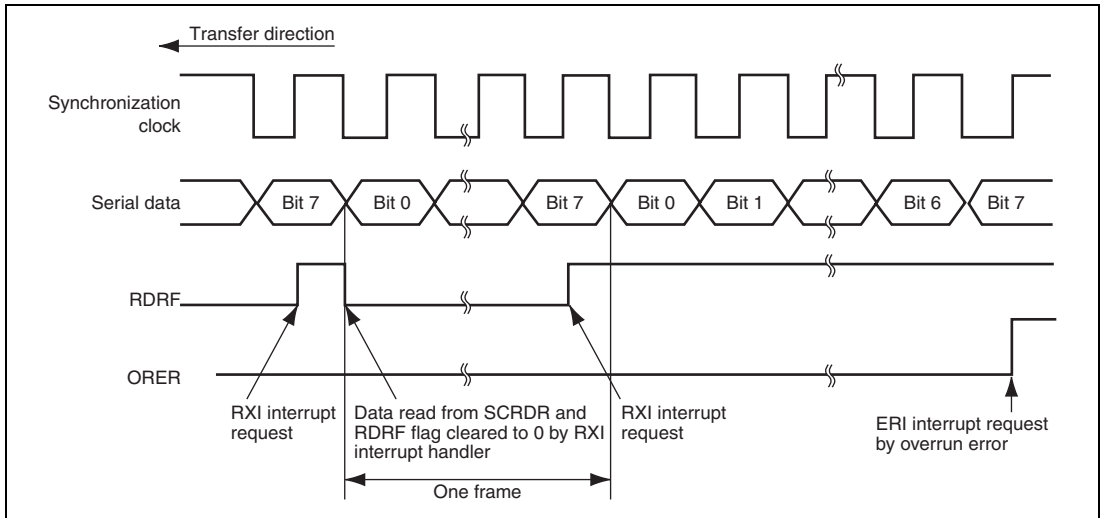
**Figure 12.12 Sample Flowchart for Receiving Serial Data (2)**

**In receiving, the SCI operates as follows:**

1. The SCI synchronizes with serial clock input or output and initializes internally.
2. Receive data is shifted into SCRSR in order from the LSB to the MSB. After receiving the data, the SCI checks whether the RDRF flag is 0 and the receive data can be transferred from SCRSR to SCRDR. If this check is passed, the SCI sets the RDRF flag to 1 and stores the received data in SCRDR. If a receive error is detected, the SCI operates as shown in table 12.16. In this state, subsequent reception cannot be continued. In addition, the RDRF flag will not be set to 1 after reception; be sure to clear the RDRF flag to 0.
3. After setting RDRF to 1, if the receive-data-full interrupt enable bit (RIE) is set to 1 in SCSCR, the SCI requests a receive-data-full interrupt (RXI). If the ORER bit is set to 1 and the RIE bit in SCSCR is also set to 1, the SCI requests a receive error interrupt (ERI).



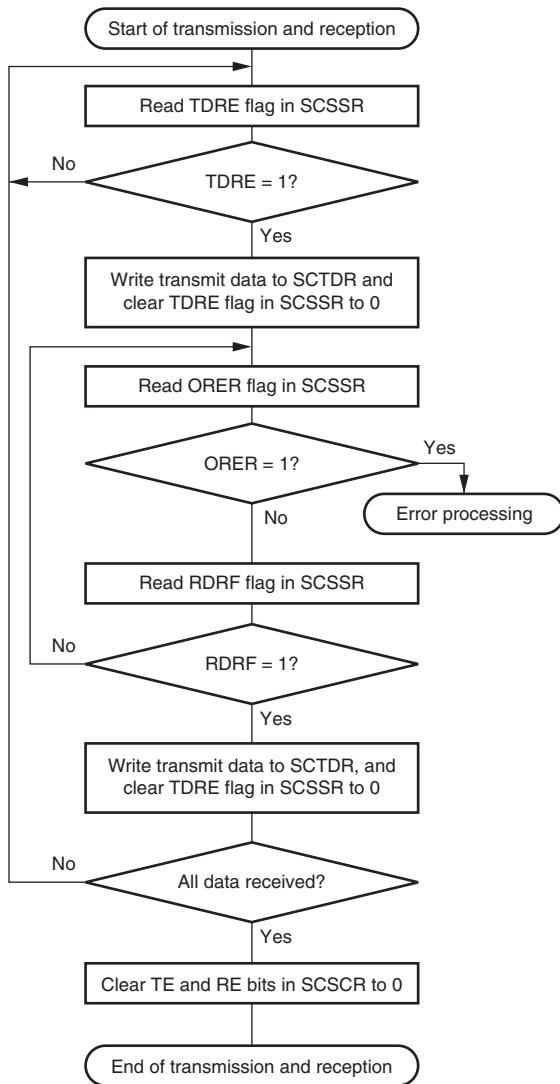
Figure 12.13 shows an example of SCI receive operation.



**Figure 12.13 Example of SCI Receive Operation**

**Transmitting and Receiving Serial Data Simultaneously (Clock Synchronous Mode):** Figure 12.14 shows a sample flowchart for transmitting and receiving serial data simultaneously.

Use the following procedure for serial data transmission and reception after enabling the SCI for transmission and reception.



- [1] SCI status check and transmit data write:  
Read SCSSR and check that the TDRE flag is set to 1, then write transmit data to SCTDR and clear the TDRE flag to 0. Transition of the TDRE flag from 0 to 1 can also be identified by a TXI interrupt.
- [2] Receive error processing:  
If a receive error occurs, read the ORER flag in SCSSR, and after performing the appropriate error processing, clear the ORER flag to 0. Reception cannot be resumed if the ORER flag is set to 1.
- [3] SCI status check and receive data read:  
Read SCSSR and check that the RDRF flag is set to 1, then read the receive data in SCRDR and clear the RDRF flag to 0. Transition of the RDRF flag from 0 to 1 can also be identified by an RXI interrupt.
- [4] Serial transmission/reception continuation procedure:  
To continue serial transmission/reception, before the MSB (bit 7) of the current frame is received, finish reading the RDRF flag, reading SCRDR, and clearing the RDRF flag to 0. Also, before the MSB (bit 7) of the current frame is transmitted, read 1 from the TDRE flag to confirm that writing is possible. Then write data to SCTDR and clear the TDRE flag to 0.

Note: When switching from transmit or receive operation to simultaneous transmit and receive operations, first clear the TE bit and RE bit to 0, then set both these bits to 1 simultaneously.

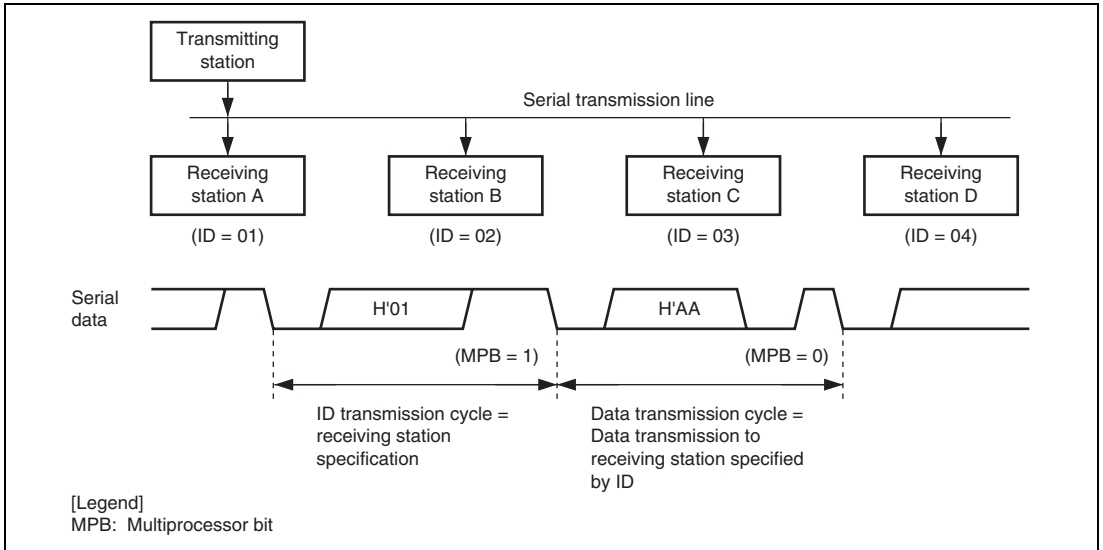
**Figure 12.14 Sample Flowchart for Transmitting/Receiving Serial Data**

#### 12.4.4 Multiprocessor Communication Function

Use of the multiprocessor communication function enables data transfer to be performed among a number of processors sharing communication lines by means of asynchronous serial communication using the multiprocessor format, in which a multiprocessor bit is added to the transfer data. When multiprocessor communication is carried out, each receiving station is addressed by a unique ID code. The serial communication cycle consists of two component cycles: an ID transmission cycle that specifies the receiving station, and a data transmission cycle. The multiprocessor bit is used to differentiate between the ID transmission cycle and the data transmission cycle. If the multiprocessor bit is 1, the cycle is an ID transmission cycle, and if the multiprocessor bit is 0, the cycle is a data transmission cycle. Figure 12.15 shows an example of inter-processor communication using the multiprocessor format. The transmitting station first sends the ID code of the receiving station with which it wants to perform serial communication as data with a 1 multiprocessor bit added. It then sends transmit data as data with a 0 multiprocessor bit added. The receiving station skips data until data with a 1 multiprocessor bit is sent. When data with a 1 multiprocessor bit is received, the receiving station compares that data with its own ID. The station whose ID matches then receives the data sent next. Stations whose ID does not match continue to skip data until data with a 1 multiprocessor bit is again received.

The SCI uses the MPIE bit in SCSCR to implement this function. When the MPIE bit is set to 1, transfer of receive data from SCRSR to SCRDR, error flag detection, and setting the SCSSR status flags, RDRF, FER, and OER to 1 are inhibited until data with a 1 multiprocessor bit is received. On reception of receive character with a 1 multiprocessor bit, the MPB bit in SCSSR is set to 1 and the MPIE bit is automatically cleared, thus normal reception is resumed. If the RIE bit in SCSCR is set to 1 at this time, an RXI interrupt is generated.

When the multiprocessor format is selected, the parity bit setting is invalid. All other bit settings are the same as those in normal asynchronous mode. The clock used for multiprocessor communication is the same as that in normal asynchronous mode.



**Figure 12.15 Example of Communication Using Multiprocessor Format (Transmission of Data H'AA to Receiving Station A)**

## 12.4.5 Multiprocessor Serial Data Transmission

Figure 12.16 shows a sample flowchart for multiprocessor serial data transmission. For an ID transmission cycle, set the MPBT bit in SCSSR to 1 before transmission. For a data transmission cycle, clear the MPBT bit in SCSSR to 0 before transmission. Note that the MPBT bit must be held 1 until when an ID is transmitted. All other SCI operations are the same as those in asynchronous mode.

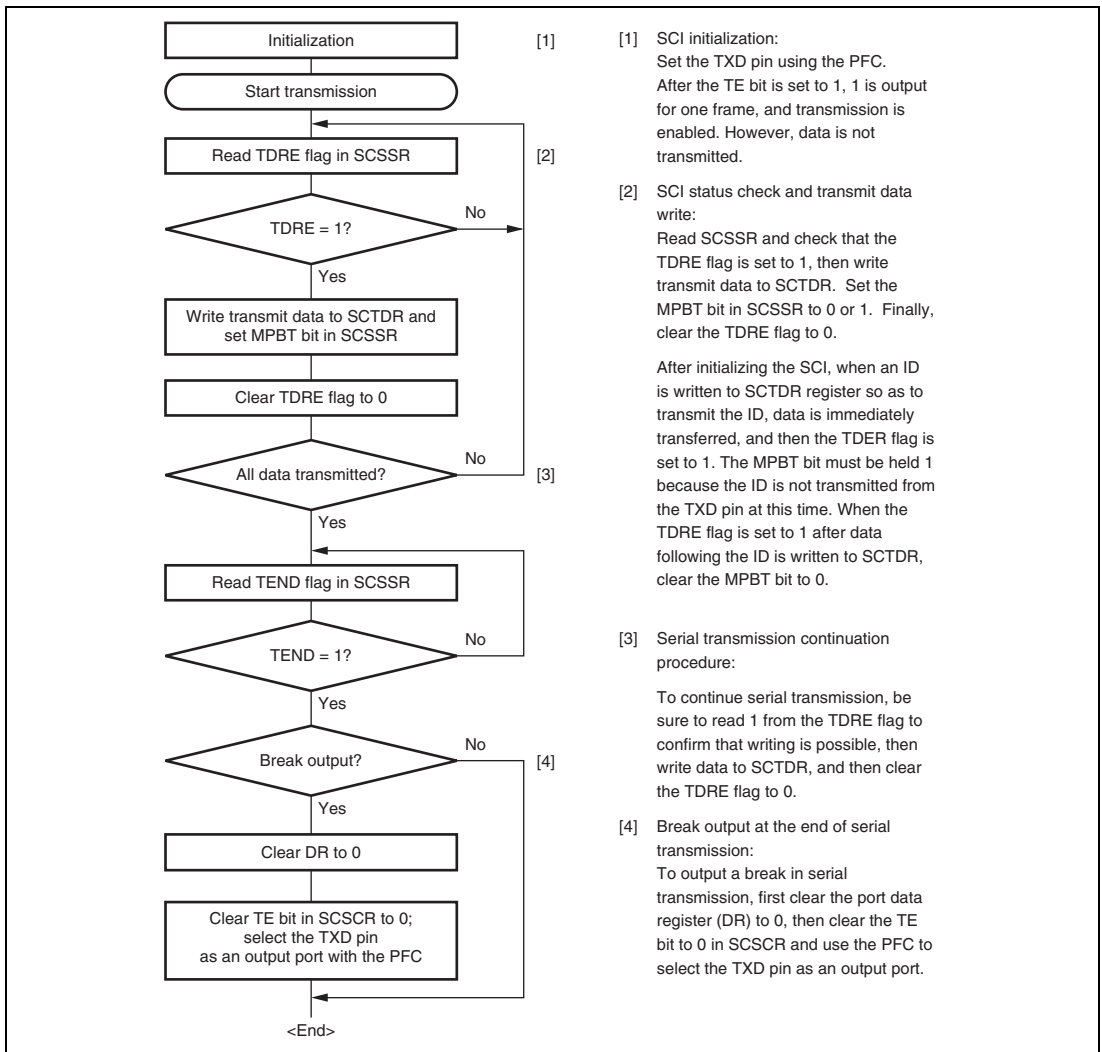
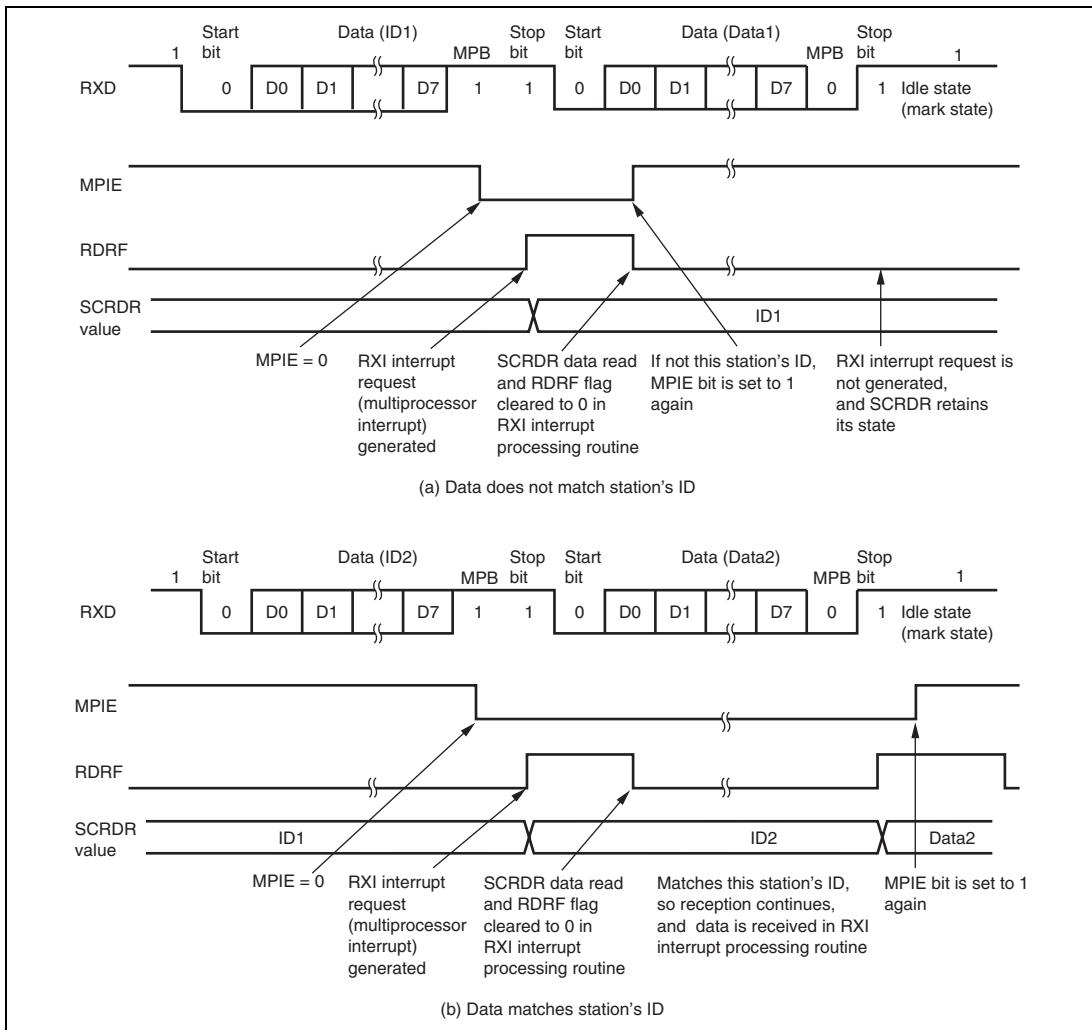


Figure 12.16 Sample Multiprocessor Serial Transmission Flowchart

### 12.4.6 Multiprocessor Serial Data Reception

Figure 12.17 shows a sample flowchart for multiprocessor serial data reception. If the MPIE bit in SCSCR is set to 1, data is skipped until data with a 1 multiprocessor bit is sent. On receiving data with a 1 multiprocessor bit, the receive data is transferred to SCRDR. An RXI interrupt request is generated at this time. All other SCI operations are the same as in asynchronous mode. Figure 12.18 shows an example of SCI operation for multiprocessor format reception.



**Figure 12.17 Example of SCI Operation in Reception  
(Example with 8-Bit Data, Multiprocessor Bit, One Stop Bit)**

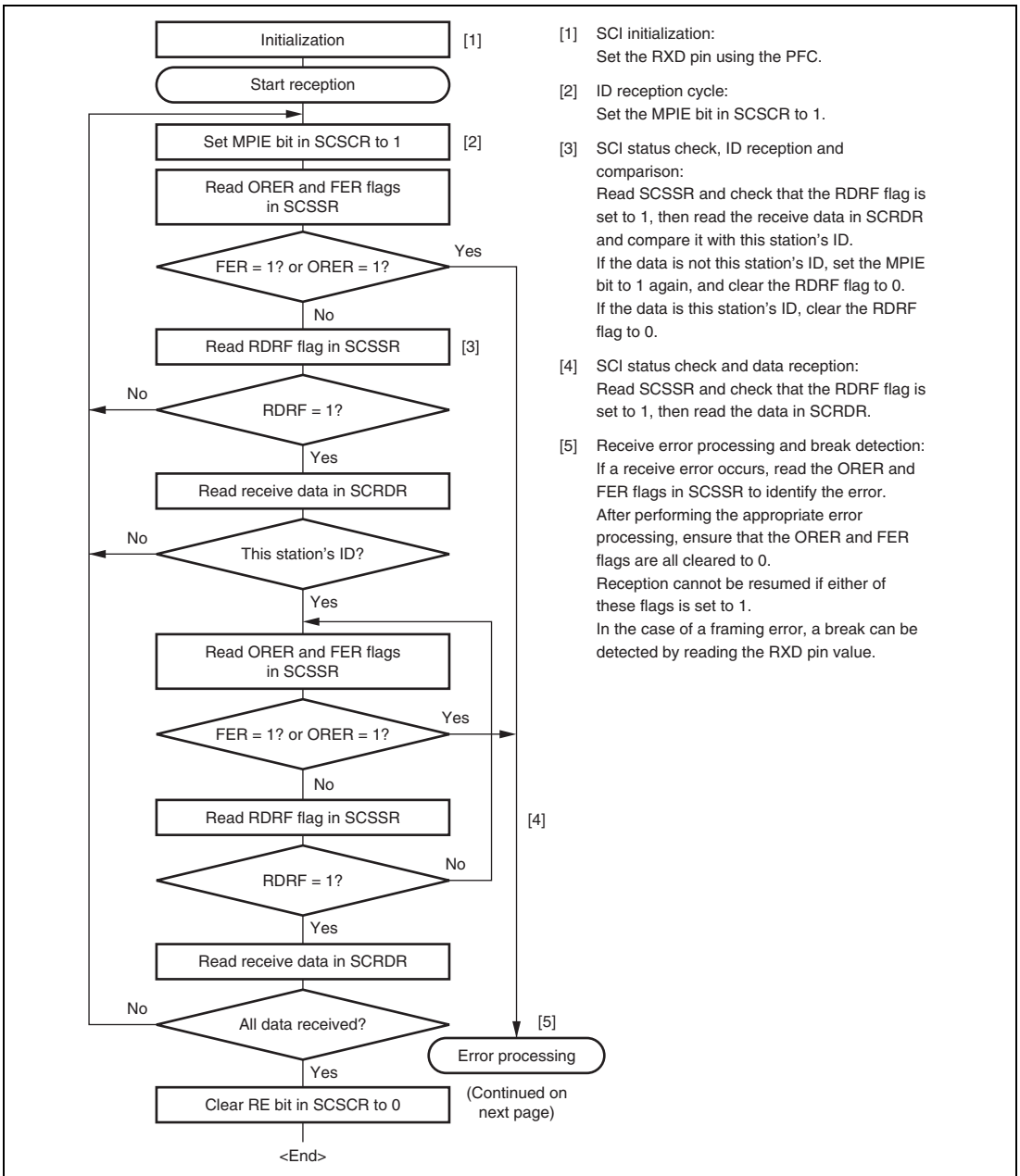
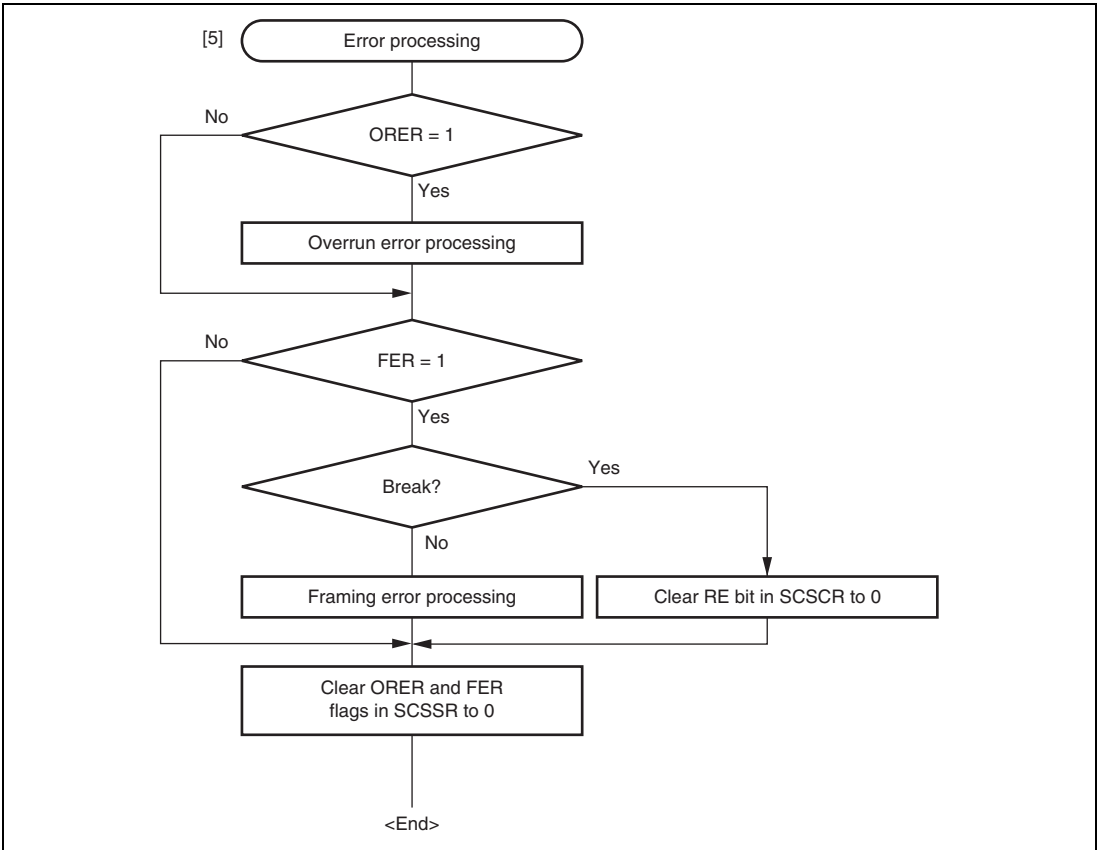


Figure 12.18 Sample Multiprocessor Serial Reception Flowchart (1)



**Figure 12.18 Sample Multiprocessor Serial Reception Flowchart (2)**



## 12.5 SCI Interrupt Sources

The SCI has four interrupt sources: transmit end (TEI), receive error (ERI), receive-data-full (RXI), and transmit-data-empty (TXI) interrupt requests.

Table 12.17 shows the interrupt sources. The interrupt sources are enabled or disabled by means of the TIE, RIE, and TEIE bits in SCSCR and the EIO bit in SCSPTR. A separate interrupt request is sent to the interrupt controller for each of these interrupt sources.

When the TDRE flag in the serial status register (SCSSR) is set to 1, a TDR empty interrupt request is generated. When the RDRF flag in SCSSR is set to 1, an RDR full interrupt request is generated. When the ORER, FER, or PER flag in SCSSR is set to 1, an ERI interrupt request is generated. When the TEND flag in SCSSR is set to 1, a TEI interrupt request is generated.

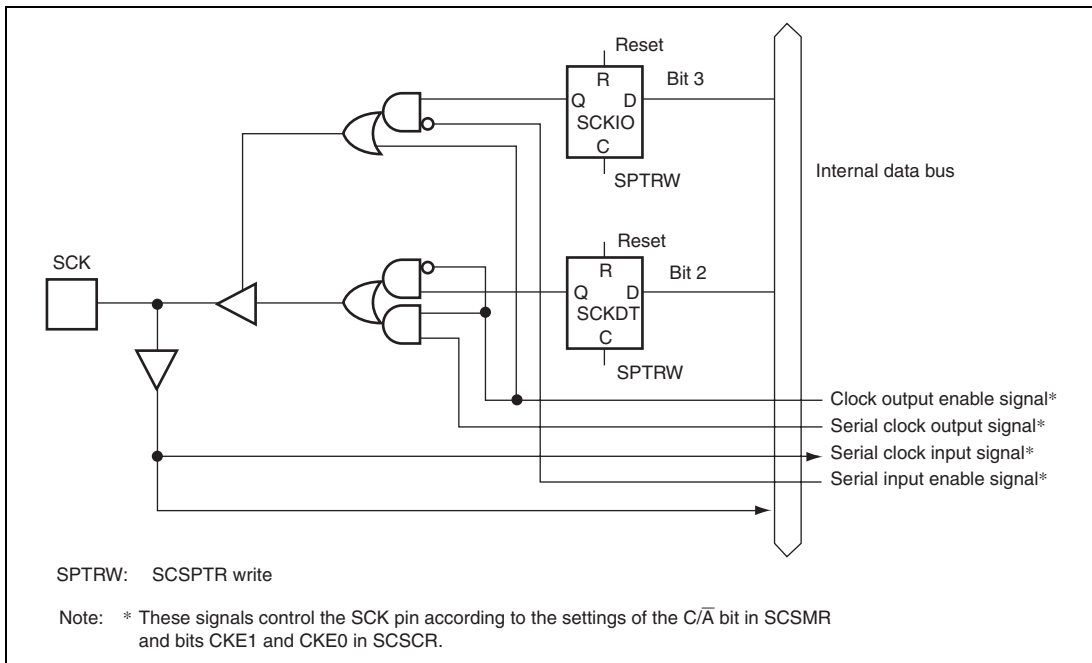
The TXI interrupt indicates that transmit data can be written, and the TEI interrupt indicates that transmission has been completed.

**Table 12.17 SCI Interrupt Sources**

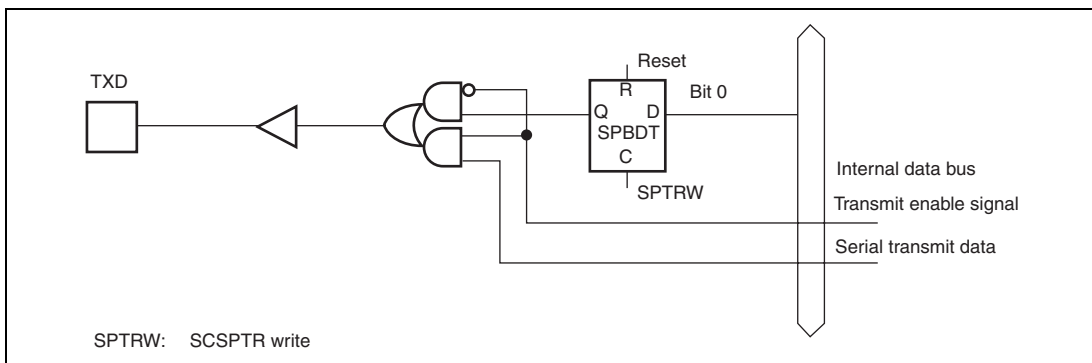
<b>Interrupt Source</b>	<b>Description</b>
ERI	Interrupt caused by receive error (ORER, FER, or PER)
RXI	Interrupt caused by receive data full (RDRF)
TXI	Interrupt caused by transmit data empty (TDRE)
TEI	Interrupt caused by transmit end (TENT)

## 12.6 Serial Port Register (SCSPTR) and SCI Pins

The relationship between SCSPTR and the SCI pins is shown in figures 12.19 and 12.20.



**Figure 12.19 SPB1IO bit, SPB1DT bit, and SCK Pin**



**Figure 12.20 SPB0DT bit and TXD Pin**

## 12.7 Usage Notes

### 12.7.1 SCTDR Writing and TDRE Flag

The TDRE flag in the serial status register (SCSSR) is a status flag indicating transferring of transmit data from SCTDR into SCTSR. The SCI sets the TDRE flag to 1 when it transfers data from SCTDR to SCTSR.

Data can be written to SCTDR regardless of the TDRE bit status.

If new data is written in SCTDR when TDRE is 0, however, the old data stored in SCTDR will be lost because the data has not yet been transferred to SCTSR. Before writing transmit data to SCTDR, be sure to check that the TDRE flag is set to 1.

### 12.7.2 Multiple Receive Error Occurrence

If multiple receive errors occur at the same time, the status flags in SCSSR are set as shown in table 12.18. When an overrun error occurs, data is not transferred from the receive shift register (SCRSR) to the receive data register (SCRDR) and the received data will be lost.

**Table 12.18 SCSSR Status Flag Values and Transfer of Received Data**

Receive Errors Generated	SCSSR Status Flags				Receive Data Transfer from SCRSR to SCRDR
	RDRF	ORER	FER	PER	
Overrun error	1	1	0	0	Not transferred
Framing error	0	0	1	0	Transferred
Parity error	0	0	0	1	Transferred
Overrun error + framing error	1	1	1	0	Not transferred
Overrun error + parity error	1	1	0	1	Not transferred
Framing error + parity error	0	0	1	1	Transferred
Overrun error + framing error + parity error	1	1	1	1	Not transferred

### 12.7.3 Break Detection and Processing

Break signals can be detected by reading the RXD pin directly when a framing error (FER) is detected. In the break state the input from the RXD pin consists of all 0s, so the FER flag is set and the parity error flag (PER) may also be set. Note that, although transfer of received data to SCRDR is halted in the break state, the SCI receiver continues to operate.

### 12.7.4 Sending a Break Signal

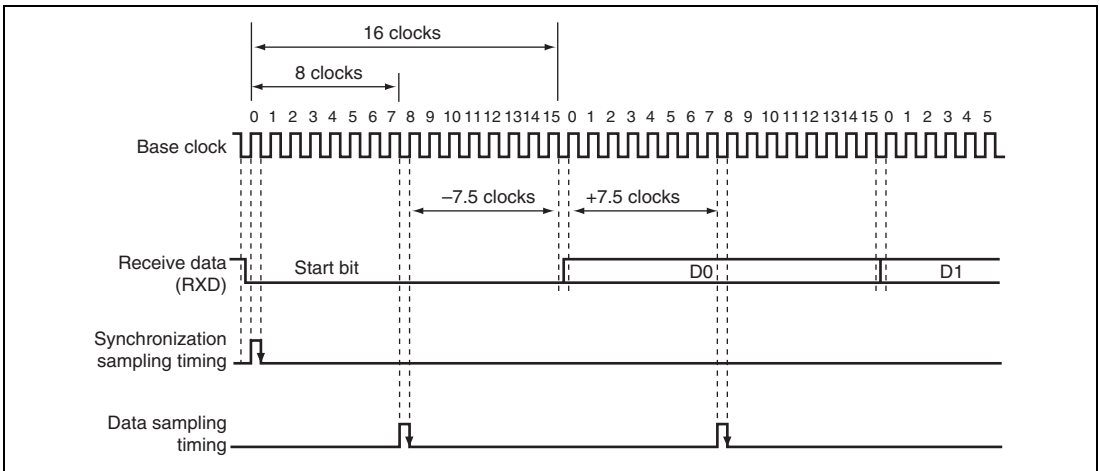
The I/O condition and level of the TXD pin are determined by the SPB0DT bit in the serial port register (SCSPTR). This feature can be used to send a break signal.

Until TE bit is set to 1 (enabling transmission) after initializing, TXD pin does not work. During the period, mark status is performed by SPB0DT bit. Therefore, the SPB0DT bit should be set to 1 at first (high level output).

To send a break signal during serial transmission, clear the SPB0DT bit to 0 (low level), then clear the TE bit to 0 (halting transmission). When the TE bit is cleared to 0, the transmitter is initialized regardless of the current transmission state, and 0 is output from the TXD pin.

### 12.7.5 Receive Data Sampling Timing and Receive Margin (Asynchronous Mode)

The SCI operates on a base clock with a frequency of 16 times the transfer rate in asynchronous mode. In reception, the SCI synchronizes internally with the fall of the start bit, which it samples on the base clock. Receive data is latched at the rising edge of the eighth base clock pulse. The timing is shown in figure 12.21.



**Figure 12.21 Receive Data Sampling Timing in Asynchronous Mode**

The receive margin in asynchronous mode can therefore be expressed as shown in equation 1.

**Equation 1:**

$$M = \left| \left( 0.5 - \frac{1}{2N} \right) - (L - 0.5) F - \frac{|D - 0.5|}{N} (1+F) \right| \times 100 \%$$

Where: M: Receive margin (%)

N: Ratio of bit rate to clock ( $N = 16$ )

D: Clock duty ( $D = 0$  to  $1.0$ )

L: Frame length ( $L = 9$  to  $12$ )

F: Absolute deviation of clock frequency

From equation 1, if  $F = 0$  and  $D = 0.5$ , the receive margin is 46.875%, as given by equation 2.

**Equation 2:**

When  $D = 0.5$  and  $F = 0$ :

$$\begin{aligned} M &= (0.5 - 1/(2 \times 16)) \times 100\% \\ &= 46.875\% \end{aligned}$$

This is a theoretical value. A reasonable margin to allow in system designs is 20% to 30%.

### **12.7.6 Note on Using External Clock in Clock Synchronous Mode**

TE and RE must be set to 1 after waiting for four or more cycles of the peripheral operating clock after the SCK external clock is changed from 0 to 1.

TE and RE must be set to 1 only while the SCK external clock is 1.

### **12.7.7 Module Standby Mode Setting**

SCI operation can be disabled or enabled using the standby control register. The initial setting is for SCI operation to be halted. Register access is enabled by clearing module standby mode. For details, see section 19, Power-Down Modes.

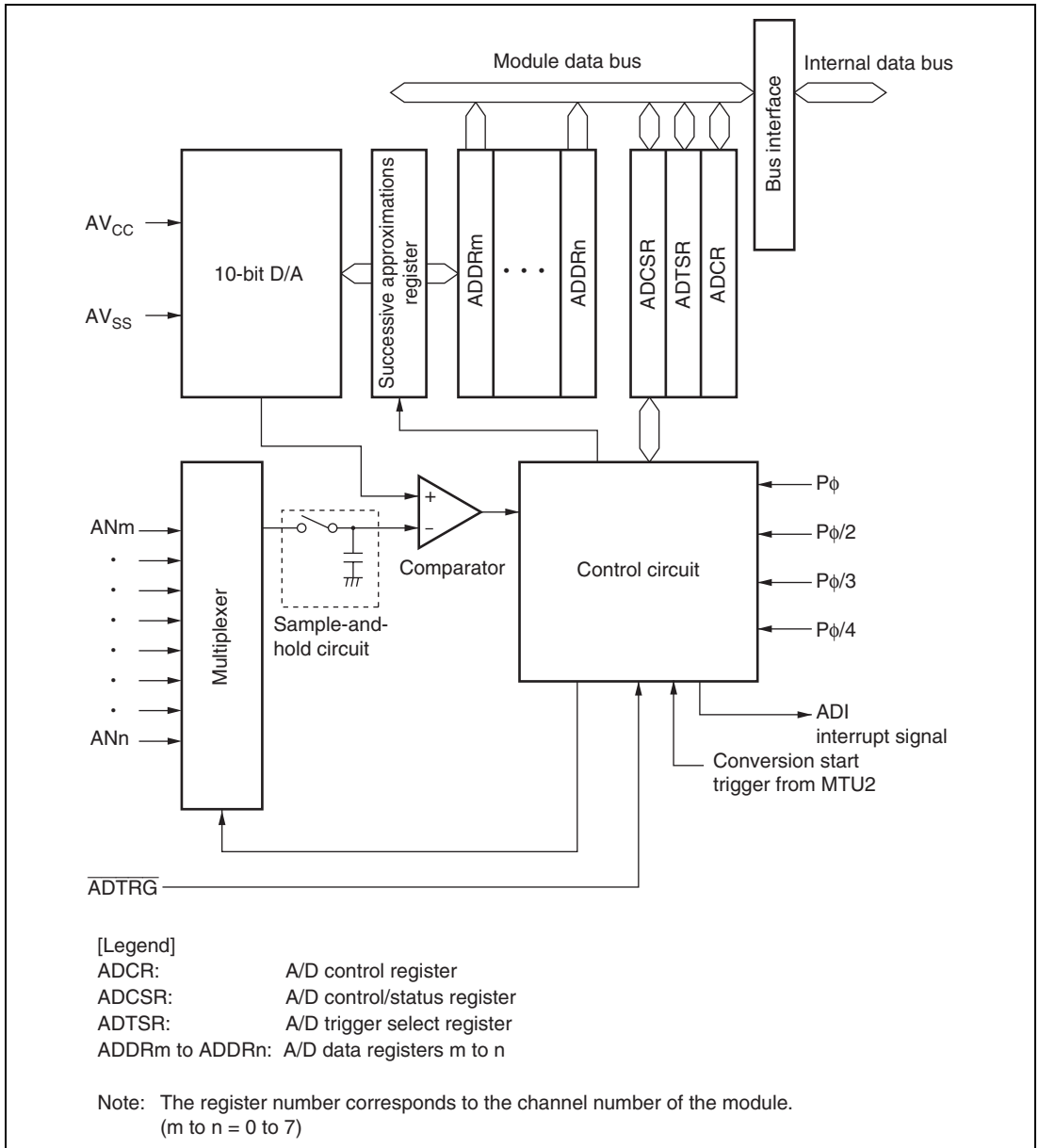
## Section 13 A/D Converter (ADC)

This LSI includes a successive approximation type 10-bit A/D converter.

### 13.1 Features

- 10-bit resolution
- Input channels
  - 8 channels (two independent A/D conversion modules)
- Conversion time: 2.0  $\mu$ s per channel (preliminary value, operation when  $P\phi = 25$  MHz)
- Three operating modes
  - Single mode: Single-channel A/D conversion
  - Continuous scan mode: Repetitive A/D conversion on up to four channels
  - Single-cycle scan mode: Continuous A/D conversion on up to four channels
- Data registers
  - Conversion results are held in a 16-bit data register for each channel
- Sample-and-hold function
- Three methods for conversion start
  - Software
  - Conversion start trigger from multifunction timer pulse unit 2 (MTU2)
  - External trigger signal
- Interrupt request
  - An A/D conversion end interrupt request (ADI) can be generated
- Module standby mode can be set

Figure 13.1 shows a block diagram of the A/D converter.



**Figure 13.1 Block Diagram of A/D Converter (for One Module)**



## 13.2 Input/Output Pins

Table 13.1 summarizes the input pins used by the A/D converter. This LSI has two A/D conversion modules, each of which can be operated independently. The input channels of A/D modules 0 and 1 are divided into two channel groups.

**Table 13.1 Pin Configuration**

Module Type	Symbol	I/O	Function	
Common	$AV_{CC}$	Input	Analog block power supply and reference voltage	
	$AV_{SS}$	Input	Analog block ground and reference voltage	
	$\overline{ADTRG}$	Input	A/D external trigger input pin*	
A/D module 0 (A/D_0)	AN0	Input	Analog input pin 0	Group 0
	AN1	Input	Analog input pin 1	
	AN2	Input	Analog input pin 2	Group 1
	AN3	Input	Analog input pin 3	
A/D module 1 (A/D_1)	AN4	Input	Analog input pin 4	Group 0
	AN5	Input	Analog input pin 5	
	AN6	Input	Analog input pin 6	Group 1
	AN7	Input	Analog input pin 7	

Notes: The connected A/D module differs for each pin. The control registers of each module must be set.

\* This pin is supported only by the SH7125.

### 13.3 Register Descriptions

The A/D converter has the following registers. For details on register addresses and register states in each processing state, refer to section 20, List of Registers.

**Table 13.2 Register Configuration**

Register Name	Abbreviation	R/W	Initial Value	Address	Access Size
A/D data register 0	ADDR0	R	H'0000	H'FFFC900	16
A/D data register 1	ADDR1	R	H'0000	H'FFFC902	16
A/D data register 2	ADDR2	R	H'0000	H'FFFC904	16
A/D data register 3	ADDR3	R	H'0000	H'FFFC906	16
A/D control/status register_0	ADCSR_0	R/W	H'0000	H'FFFC910	16
A/D control register_0	ADCR_0	R/W	H'0000	H'FFFC912	16
A/D data register 4	ADDR4	R	H'0000	H'FFFC980	16
A/D data register 5	ADDR5	R	H'0000	H'FFFC982	16
A/D data register 6	ADDR6	R	H'0000	H'FFFC984	16
A/D data register 7	ADDR7	R	H'0000	H'FFFC986	16
A/D control/status register_1	ADCSR_1	R/W	H'0000	H'FFFC990	16
A/D control register_1	ADCR_1	R/W	H'0000	H'FFFC992	16
A/D trigger select register_0	ADTSR_0	R/W	H'0000	H'FFFE890	8, 16

### 13.3.1 A/D Data Registers 0 to 7 (ADDR0 to ADDR7)

ADDRs are 16-bit read-only registers. The conversion result for each analog input channel is stored in ADDR with the corresponding number. (For example, the conversion result of AN4 is stored in ADDR4.)

The converted 10-bit data is stored in bits 6 to 15. The lower 6 bits are always read as 0.

The data bus between the CPU and the A/D converter is 16 bits wide. When reading from ADDR, access must be performed in words. The initial value of ADDR is H'0000.

Bit:	15	14	13	12	11	10	9	8	7	6	5	4	3	2	1	0
											-	-	-	-	-	-
Initial value:	0	0	0	0	0	0	0	0	0	0	0	0	0	0	0	0
R/W:	R	R	R	R	R	R	R	R	R	R	R	R	R	R	R	R

### 13.3.2 A/D Control/Status Registers\_0 and \_1 (ADCSR\_0 and ADCSR\_1)

ADCSR for each module controls A/D conversion operations.

Bit:	15	14	13	12	11	10	9	8	7	6	5	4	3	2	1	0
	ADF	ADIE	-	-	TRGE	-	CONADF	STC	CKSL[1:0]	ADM[1:0]	ADCS	CH[2:0]				
Initial value:	0	0	0	0	0	0	0	0	0	0	0	0	0	0	0	0
R/W:	R/(W)*(	R/W	R	R	R/W	R	R/W	R/W	R/W	R/W	R/W	R/W	R/W	R/W	R/W	R/W

Note: \* Writing 0 to this bit after reading it as 1 clears the flag and is the only allowed way.

Bit	Bit Name	Initial Value	R/W	Description
15	ADF	0	R/(W)*	<p>A/D End Flag</p> <p>A status flag that indicates the end of A/D conversion.</p> <p>[Setting conditions]</p> <ul style="list-style-type: none"> <li>When A/D conversion ends in single mode</li> <li>When A/D conversion ends on all specified channels in scan mode</li> </ul> <p>[Clearing condition]</p> <ul style="list-style-type: none"> <li>When 0 is written after reading ADF = 1</li> </ul>

Bit	Bit Name	Initial Value	R/W	Description
14	ADIE	0	R/W	<p>A/D Interrupt Enable</p> <p>The A/D conversion end interrupt (ADI) request is enabled when 1 is set</p> <p>When changing the operating mode, first clear the ADST bit to 0.</p>
13, 12	—	All 0	R	<p>Reserved</p> <p>These bits are always read as 0. The write value should always be 0.</p>
11	TRGE	0	R/W	<p>Trigger Enable</p> <p>Enables or disables triggering of A/D conversion by ADTRG and an MTU2 trigger.</p> <p>0: A/D conversion triggering is disabled</p> <p>1: A/D conversion triggering is enabled</p> <p>When changing the operating mode, first clear the ADST bit to 0.</p>
10	—	0	R	<p>Reserved</p> <p>This bit is always read as 0. The write value should always be 0.</p>
9	CONADF	0	R/W	<p>ADF Control</p> <p>Controls setting of the ADF bit in 2-channel scan mode. The setting of this bit is valid only when triggering of A/D conversion is enabled (TRGE = 1) in 2-channel scan mode. The setting of this bit is ignored in single mode or 4-channel scan mode.</p> <p>0: The ADF bit is set when A/D conversion started by the group 0 trigger or group 1 trigger has finished.</p> <p>1: The ADF bit is set when A/D conversion started by the group 0 trigger and A/D conversion started by the group 1 trigger have both finished. Note that the triggering order has no affect.</p> <p>When changing the operating mode, first clear the ADST bit to 0.</p>

Bit	Bit Name	Initial Value	R/W	Description
8	STC	0	R/W	<p>State Control</p> <p>Sets the A/D conversion time in combination with the CKSL1 and CKSL0 bits.</p> <p>0: 50 states 1: 64 states</p> <p>When changing the A/D conversion time, first clear the ADST bit to 0.</p>
7, 6	CKSL[1:0]	00	R/W	<p>Clock Select 1 and 0</p> <p>Select the A/D conversion time.</p> <p>00: <math>P\phi/4</math> 01: <math>P\phi/3</math> 10: <math>P\phi/2</math> 11: <math>P\phi</math></p> <p>When changing the A/D conversion time, first clear the ADST bit to 0.</p> <p>CKSL[1:0] = B'11 can be set while <math>P\phi \leq 25</math> MHz.</p>
5, 4	ADM[1:0]	00	R/W	<p>A/D Mode 1 and 0</p> <p>Select the A/D conversion mode.</p> <p>00: Single mode 01: 4-channel scan mode 10: Setting prohibited 11: 2-channel scan mode</p> <p>When changing the operating mode, first clear the ADST bit to 0.</p>
3	ADCS	0	R/W	<p>A/D Continuous Scan</p> <p>Selects either single-cycle scan or continuous scan in scan mode. This bit is valid only when scan mode is selected.</p> <p>0: Single-cycle scan 1: Continuous scan</p> <p>When changing the operating mode, first clear the ADST bit to 0.</p>

Bit	Bit Name	Initial Value	R/W	Description
2 to 0	CH[2:0]	000	R/W	Channel Select 2 to 0 Select analog input channels. See table 13.3. When changing the operating mode, first clear the ADST bit to 0.

Note: \* Writing 0 to this bit after reading it as 1 clears the flag and is the only allowed way.

### 13.3.3 A/D Control Registers\_0 and \_1 (ADCR\_0 and ADCR\_1)

ADCR for each module controls A/D conversion.

Bit:	15	14	13	12	11	10	9	8	7	6	5	4	3	2	1	0
	-	-	ADST	-	-	-	-	-	-	-	-	-	-	-	-	-
Initial value:	0	0	0	0	0	0	0	0	0	0	0	0	0	0	0	0
R/W:	R	R	R/W	R	R	R	R	R	R	R	R	R	R	R	R	R

Bit	Bit Name	Initial Value	R/W	Description
15, 14	—	All 0	R	Reserved These bits are always read as 0. The write value should always be 0.
13	ADST	0	R/W	A/D Start Starts or stops A/D conversion. When this bit is set to 1, A/D conversion is started. When this bit is cleared to 0, A/D conversion is stopped and the A/D converter enters the idle state. In single or single-cycle scan mode, this bit is automatically cleared to 0 when A/D conversion ends on the selected single channel. In continuous scan mode, A/D conversion is continuously performed for the selected channels in sequence until this bit is cleared by a software, reset, or in software standby mode or module standby mode.
12 to 0	—	All 0	R	Reserved These bits are always read as 0. The write value should always be 0.

**Table 13.3 Channel Select List**

			Analog Input Channels			
Bit 2	Bit 1	Bit 0	Single Mode		4-Channel Scan Mode*	
CH2	CH1	CH0	A/D_0	A/D_1	A/D_0	A/D_1
0	0	0	AN0	AN4	AN0	AN4
		1	AN1	AN5	AN0, AN1	AN4, AN5
	1	0	AN2	AN6	AN0 to AN2	AN4 to AN6
		1	AN3	AN7	AN0 to AN3	AN4 to AN7
1	0	0	Setting prohibited	Setting prohibited	Setting prohibited	Setting prohibited
		1				
	1	0				
		1				

			Analog Input Channels	
Bit 2	Bit 1	Bit 0	2-Channel Scan Mode* (Activated by software)	
CH2	CH1	CH0	A/D_0	A/D_1
0	0	0	AN0	AN4
		1	AN0, AN1	AN4, AN5
	1	0	AN2	AN6
		1	AN2, AN3	AN6, AN7
1	0	0	Setting prohibited	Setting prohibited
		1		
	1	0		
		1		

## Analog Input Channels

			2-Channel Scan Mode* (Activated by Triggers MTU2 or etc.)	
Bit 2	Bit 1	Bit 0	A/D_0	A/D_1
CH2	CH1	CH0		
0	0	0	Group 0: AN0 Group 1: AN2	Group 0: AN4 Group 1: AN6
		1	Group 0: AN0, AN1 Group 1: AN2, AN3	Group 0: AN4, AN5 Group 1: AN6, AN7
	1	0	Setting prohibited	Setting prohibited
		1		
1	0	0		
		1		
	1	0		
		1		

Note: \* Continuous scan mode or single-scan mode can be selected with the ADCS bit.



### 13.3.4 A/D Trigger Select Register\_0 (ADTSR\_0)

The ADTSR\_0 enables an A/D conversion started by an external trigger signal.

In particular, the four channels in A/D module 0 are divided into two groups (group 0 and group 1) and the A/D trigger can be specified for each group independently in 2-channel scan mode.

Bit:	15	14	13	12	11	10	9	8	7	6	5	4	3	2	1	0
	TRG11S[3:0]				TRG01S[3:0]				TRG1S[3:0]				TRG0S[3:0]			
Initial value:	0	0	0	0	0	0	0	0	0	0	0	0	0	0	0	0
R/W:	R/W	R/W	R/W	R/W	R/W	R/W	R/W	R/W	R/W	R/W	R/W	R/W	R/W	R/W	R/W	R/W

Bit	Bit Name	Initial Value	R/W	Description
15 to 12	TRG11S[3:0]	0000	R/W	<p>A/D Trigger 1 Group 1 Select 3 to 0</p> <p>Select an external trigger or MTU2 trigger to start A/D conversion for group 1 when A/D module 1 is in 2-channel scan mode.</p> <p>0000: External trigger pin (<math>\overline{\text{ADTRG}}</math>) input</p> <p>0001: TRGA input capture/compare match for each MTU2 channel or TCNT_4 underflow (trough) in complementary PWM mode (TRGAN)</p> <p>0010: MTU2 channel 0 compare match (TRG0N)</p> <p>0011: MTU2 A/D conversion start request delaying (TRG4AN)</p> <p>0100: MTU2 A/D conversion start request delaying (TRG4BN)</p> <p>0101: Setting prohibited</p> <p>0110: Setting prohibited</p> <p>0111: Setting prohibited</p> <p>1xxx: Setting prohibited</p> <p>When switching the selector, first clear the ADST bit in the A/D control register (ADCR) to 0.</p> <p>Specify different trigger sources for the group 0 and group 1 conversion requests so that a group 0 conversion request is not generated simultaneously with a group 1 conversion request in 2-channel scan mode.</p>

Bit	Bit Name	Initial Value	R/W	Description
11 to 8	TRG01S[3:0]	0000	R/W	<p>A/D Trigger 0 Group 1 Select 3 to 0</p> <p>Select an external trigger or MTU2 trigger to start A/D conversion for group 1 when A/D module 0 is in 2-channel scan mode.</p> <p>0000: External trigger pin (<math>\overline{\text{ADTRG}}</math>) input</p> <p>0001: TRGA input capture/compare match for each MTU2 channel or TCNT_4 underflow (trough) in complementary PWM mode (TRGAN)</p> <p>0010: MTU2 channel 0 compare match (TRG0N)</p> <p>0011: MTU2 A/D conversion start request delaying (TRG4AN)</p> <p>0100: MTU2 A/D conversion start request delaying (TRG4BN)</p> <p>0101: Setting prohibited</p> <p>0110: Setting prohibited</p> <p>0111: Setting prohibited</p> <p>1xxx: Setting prohibited</p> <p>When switching the selector, first clear the ADST bit in the A/D control register (ADCR) to 0.</p> <p>Specify different trigger sources for the group 0 and group 1 conversion requests so that a group 0 conversion request is not generated simultaneously with a group 1 conversion request in 2-channel scan mode.</p>

Bit	Bit Name	Initial Value	R/W	Description
7 to 4	TRG1S[3:0]	0000	R/W	<p>A/D Trigger 1 Select 3 to 0</p> <p>Select an external trigger or MTU2 trigger to start A/D conversion for group 0 when A/D module 1 is in single mode, 4-channel scan mode, or 2-channel scan mode.</p> <p>0000: External trigger pin (<math>\overline{\text{ADTRG}}</math>) input</p> <p>0001: TRGA input capture/compare match for each MTU2 channel or TCNT_4 underflow (trough) in complementary PWM mode (TRGAN)</p> <p>0010: MTU2 channel 0 compare match (TRG0N)</p> <p>0011: MTU2 A/D conversion start request delaying (TRG4AN)</p> <p>0100: MTU2 A/D conversion start request delaying (TRG4BN)</p> <p>0101: Setting prohibited</p> <p>0110: Setting prohibited</p> <p>0111: Setting prohibited</p> <p>1xxx: Setting prohibited</p> <p>When switching the selector, first clear the ADST bit in the A/D control register (ADCR) to 0.</p> <p>Specify different trigger sources for the group 0 and group 1 conversion requests so that a group 0 conversion request is not generated simultaneously with a group 1 conversion request in 2-channel scan mode.</p>

Bit	Bit Name	Initial Value	R/W	Description
3 to 0	TRG0S[3:0]	0000	R/W	<p>A/D Trigger 0 Select 3 to 0</p> <p>Select an external trigger or MTU2 trigger to start A/D conversion for group 0 when A/D module 0 is in single mode, 4-channel scan mode, or 2-channel scan mode.</p> <p>0000: External trigger pin (<math>\overline{\text{ADTRG}}</math>) input</p> <p>0001: TRGA input capture/compare match for each MTU2 channel or TCNT_4 underflow (trough) in complementary PWM mode (TRGAN)</p> <p>0010: MTU2 channel 0 compare match (TRG0N)</p> <p>0011: MTU2 A/D conversion start request delaying (TRG4AN)</p> <p>0100: MTU2 A/D conversion start request delaying (TRG4BN)</p> <p>0101: Setting prohibited</p> <p>0110: Setting prohibited</p> <p>0111: Setting prohibited</p> <p>1xxx: Setting prohibited</p> <p>When switching the selector, first clear the ADST bit in the A/D control register (ADCR) to 0.</p> <p>Specify different trigger sources for the group 0 and group 1 conversion requests so that a group 0 conversion request is not generated simultaneously with a group 1 conversion request in 2-channel scan mode.</p>

## [Legend]

x: Don't care

## 13.4 Operation

The A/D converter operates by successive approximation with 10-bit resolution. It has two operating modes; single mode and scan mode. There are two kinds of scan mode: continuous mode and single-cycle mode. When changing the operating mode or analog input channel, in order to prevent incorrect operation, first clear the ADST bit to 0 in ADCR.

### 13.4.1 Single Mode

In single mode, A/D conversion is to be performed only once on the specified single channel. The operations are as follows.

1. A/D conversion is started when the ADST bit in ADCR is set to 1, according to software, MTU2, or external trigger input.
2. When A/D conversion is completed, the result is transferred to the A/D data register corresponding to the channel.
3. On completion of conversion, the ADF bit in ADCSR is set to 1. If the ADIE bit is set to 1 at this time, an ADI interrupt request is generated.
4. The ADST bit remains set to 1 during A/D conversion. When A/D conversion ends, the ADST bit is automatically cleared to 0 and the A/D converter enters the idle state.  
When the ADST bit is cleared to 0 during A/D conversion, A/D conversion stops and the A/D converter enters the idle state.

### 13.4.2 Continuous Scan Mode

In continuous scan mode, A/D conversion is to be performed sequentially on the specified channels.

1. When the ADST bit in ADCR is set to 1 by software, MTU2, or external trigger input, A/D conversion starts on the channel with the lowest number in the group (AN0, AN1, ..., AN3).
2. When A/D conversion for each channel is completed, the result is sequentially transferred to the A/D data register corresponding to each channel.
3. When conversion of all the selected channels is completed, the ADF bit in ADCSR is set to 1. If the ADIE bit is set to 1 at this time, an ADI interrupt is requested after A/D conversion ends. Conversion of the first channel in the group starts again.
4. Steps 2 to 3 are repeated as long as the ADST bit remains set to 1. When the ADST bit is cleared to 0, A/D conversion stops and the A/D converter enters the idle state.

### 13.4.3 Single-Cycle Scan Mode

In single-cycle scan mode, A/D conversion is to be performed once on the specified channels (up to four channels).

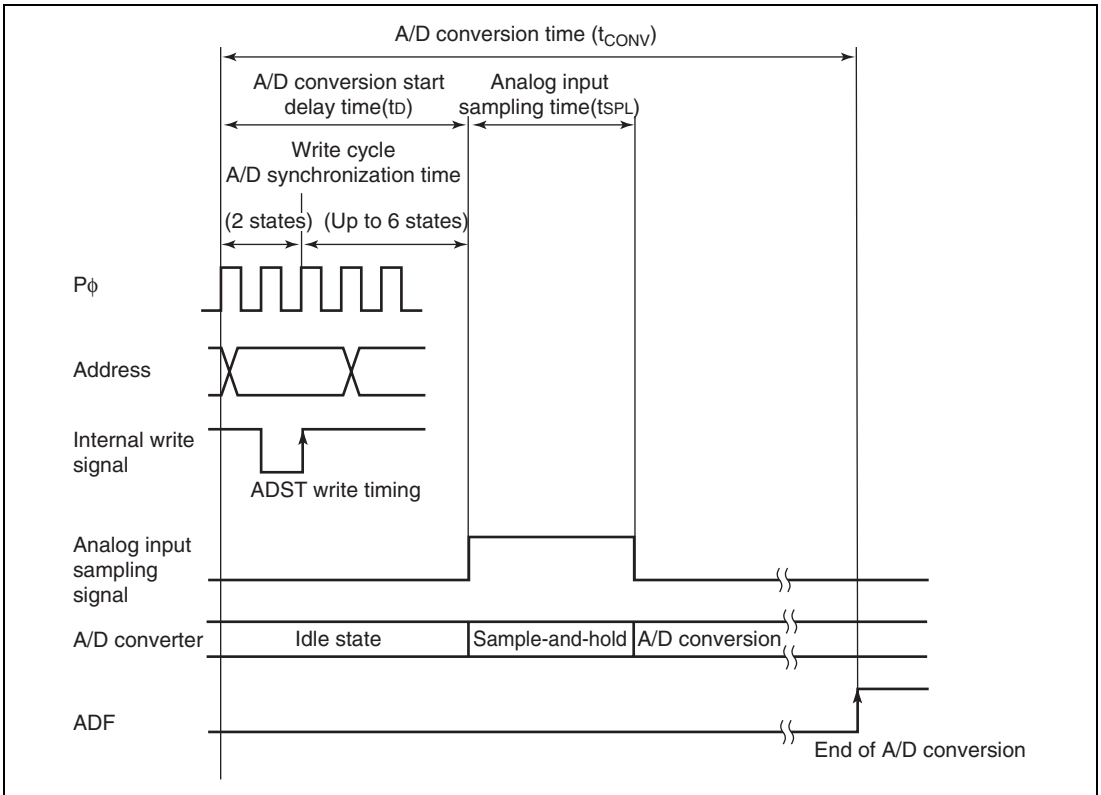
1. When the ADST bit in ADCR is set to 1 by a software, MTU2, or external trigger input, A/D conversion starts on the channel with the lowest number in the group (AN0, AN1, ..., AN3).
2. When A/D conversion for each channel is completed, the result is sequentially transferred to the A/D data register corresponding to each channel.
3. When conversion of all the selected channels is completed, the ADF bit in ADCSR is set to 1. If the ADIE bit is set to 1 at this time, an ADI interrupt is requested after A/D conversion ends.
4. After A/D conversion ends, the ADST bit is automatically cleared to 0 and the A/D converter enters the idle state. When the ADST bit is cleared to 0 during A/D conversion, A/D conversion stops and the A/D converter enters the idle state.

### 13.4.4 Input Sampling and A/D Conversion Time

The A/D converter has a built-in sample-and-hold circuit for each module. The A/D converter samples the analog input when the A/D conversion start delay time ( $t_d$ ) has passed after the ADST bit in ADCR is set to 1, then starts conversion. Figure 13.2 shows the A/D conversion timing. Table 13.4 shows the A/D conversion time.

As indicated in figure 13.2, the A/D conversion time ( $t_{\text{CONV}}$ ) includes  $t_d$  and the input sampling time ( $t_{\text{SPL}}$ ). The length of  $t_d$  varies depending on the timing of the write access to ADCR. The total conversion time therefore varies within the ranges indicated in table 13.4.

In scan mode, the values given in table 13.4 apply to the first conversion time. The values given in table 13.5 apply to the second and subsequent conversions.



**Figure 13.2 A/D Conversion Timing**

**Table 13.4 A/D Conversion Time (Single Mode)**

		STC = 0											
		CKSL1 = 0						CKSL1 = 1					
		CKSL0 = 0			CKSL0 = 1			CKSL0 = 0			CKSL0 = 1		
Item	Symbol	Min.	Typ.	Max.	Min.	Typ.	Max.	Min.	Typ.	Max.	Min.	Typ.	Max.
A/D conversion start delay time	$t_d$	2	—	6	2	—	5	2	—	4	2	—	3
Input sampling time	$t_{SPL}$	—	24	—	—	18	—	—	12	—	—	6	—
A/D conversion time	$t_{CONV}$	202	—	206	152	—	155	102	—	104	52	—	53

		STC = 1											
		CKSL1 = 0						CKSL1 = 1					
		CKSL0 = 0			CKSL0 = 1			CKSL0 = 0			CKSL0 = 1		
Item	Symbol	Min.	Typ.	Max.	Min.	Typ.	Max.	Min.	Typ.	Max.	Min.	Typ.	Max.
A/D conversion start delay time	$t_d$	2	—	6	2	—	5	2	—	4	2	—	3
Input sampling time	$t_{SPL}$	—	36	—	—	27	—	—	18	—	—	9	—
A/D conversion time	$t_{CONV}$	258	—	262	194	—	197	130	—	132	66	—	67

Note: All values represent the number of states for  $P\phi$ .

**Table 13.5 A/D Conversion Time (Scan Mode)**

STC	CKSL1	CKSL0	Conversion Time (State)	Conversion Time Calculation Example	
				$P\phi = 25 \text{ MHz}$	$P\phi = 40 \text{ MHz}$
0	0	0	200 (Fixed)	8 $\mu\text{s}$	5 $\mu\text{s}$
		1	150 (Fixed)	6 $\mu\text{s}$	3.8 $\mu\text{s}$
	1	0	100 (Fixed)	4 $\mu\text{s}$	2.5 $\mu\text{s}$
		1	50 (Fixed)	2 $\mu\text{s}$	Setting prohibited
1	0	0	256 (Fixed)	10.2 $\mu\text{s}$	6.4 $\mu\text{s}$
		1	192 (Fixed)	7.7 $\mu\text{s}$	4.8 $\mu\text{s}$
	1	0	128 (Fixed)	5.1 $\mu\text{s}$	3.2 $\mu\text{s}$
		1	64 (Fixed)	2.6 $\mu\text{s}$	Setting prohibited



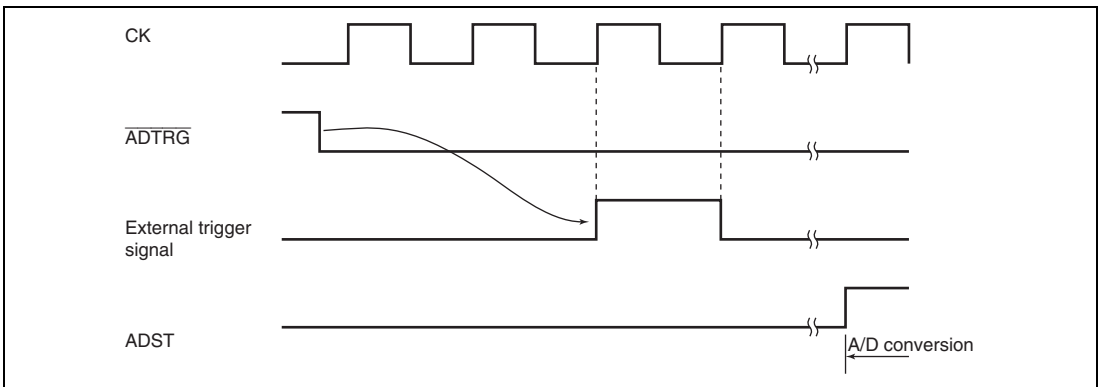
### 13.4.5 A/D Converter Activation by MTU2

The A/D converter can be independently activated by an A/D conversion request from the interval timer of the MTU2.

To activate the A/D converter by the MTU2, first set the TRGE bit in the A/D control/status register (ADCSR) to 1, and then set the A/D trigger select register (ADTSR). After this register setting has been made, the ADST bit in ADCR is automatically set to 1 when an A/D conversion request from the interval timer of the MTU2 occurs. The timing from setting of the ADST bit until the start of A/D conversion is the same as when 1 is written to the ADST bit by software.

### 13.4.6 External Trigger Input Timing

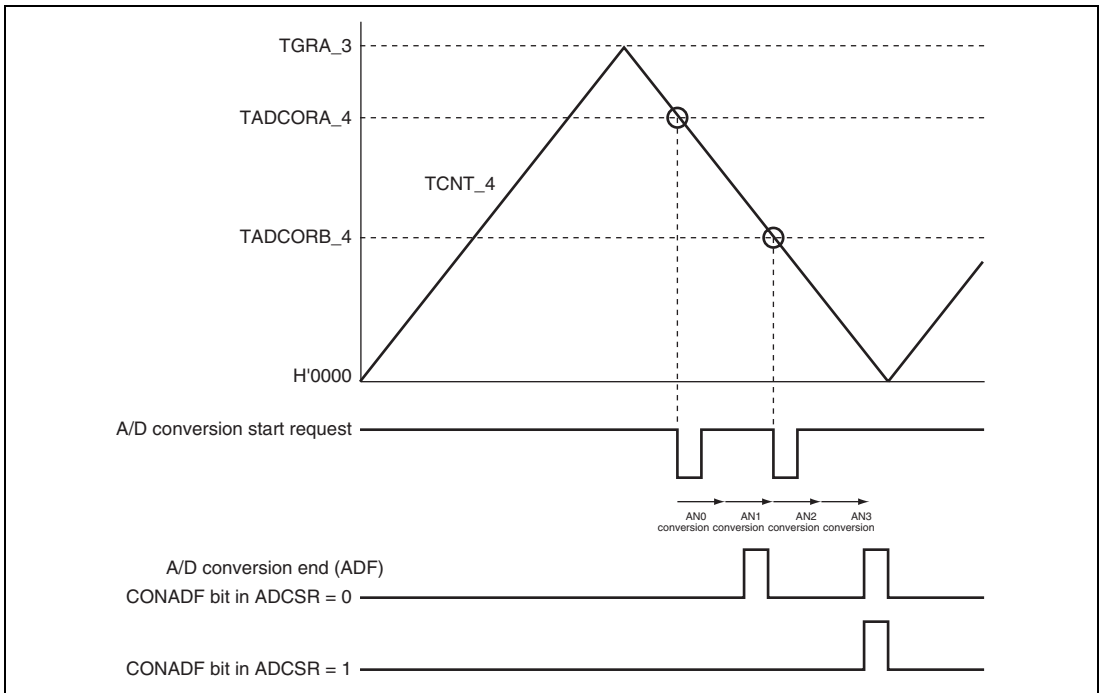
A/D conversion can be externally triggered. When the TRGE bit in the A/D control/status register (ADCSR) is set to 1 while the TRGS3 to TRGS0 bits in the A/D trigger select register\_0 (ADTSR\_0) is set to external trigger input, external trigger input is enabled at the  $\overline{\text{ADTRG}}$  pin. A falling edge of the  $\overline{\text{ADTRG}}$  pin sets the ADST bit to 1 in ADCR, starting A/D conversion. Other operations, in both single and scan modes, are the same as when the ADST bit has been set to 1 by software. Figure 13.3 shows the timing.



**Figure 13.3 External Trigger Input Timing**

### 13.4.7 2-Channel Scanning

In 2-channel scan mode, since the four channels of analog input are divided into groups 0 and 1, triggers for activation of groups 0 and 1 are independently specifiable. Conversion end interrupts in 2-channel scan mode can be generated either on completion of group 0 or group 1 or on completion of group 0 and group 1. If conversion is to be started by triggers, the different sources for groups 0 and 1 are specified in ADTSR. A request for conversion by group 1 generated during conversion by group 0 is ignored. Figure 13.4 shows an example of operation when TRG4AN of the MTU2 has been specified as the A/D conversion start request by group 0 and TRG4BN of the MTU2 has been specified as the A/D conversion start request by group 1.



**Figure 13.4 Example of 2-Channel Scanning**

## 13.5 Interrupt Sources

The A/D converter can generate an A/D conversion end interrupt request. The ADI interrupt can be enabled by setting the ADIE bit in the A/D control/status register (ADCSR) to 1, or disabled by clearing the ADIE bit to 0.

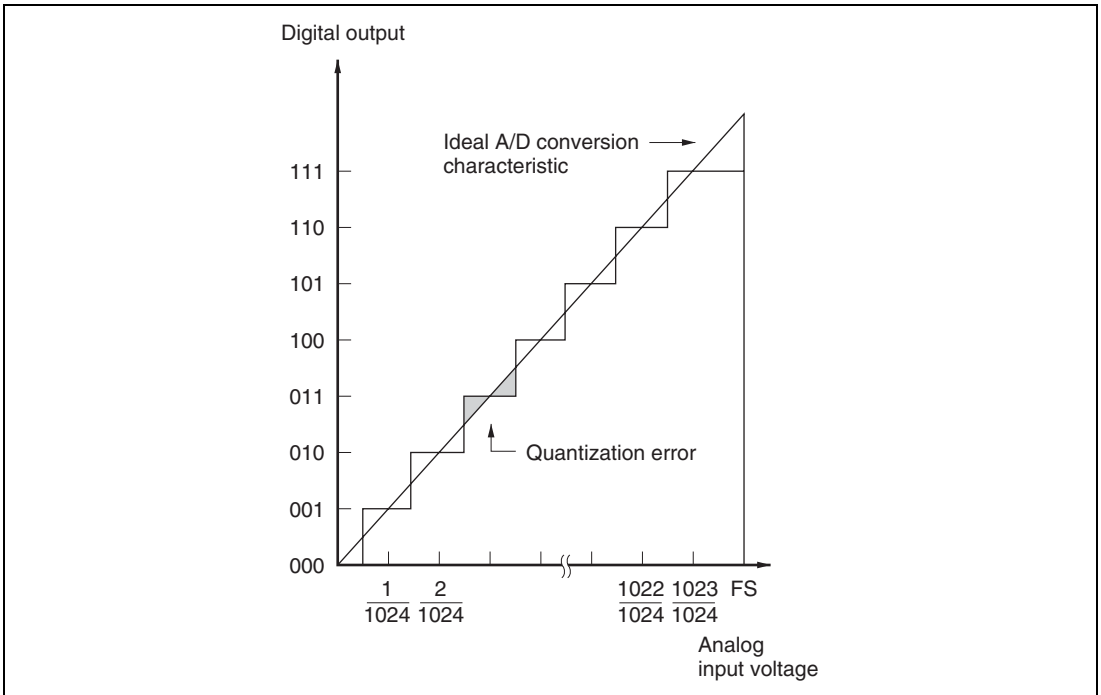
**Table 13.6 A/D Converter Interrupt Source**

<b>Name</b>	<b>Interrupt Source</b>	<b>Interrupt Source Flag</b>
AD10	A/D_0 conversion completed	ADF in ADCSR_0
AD11	A/D_1 conversion completed	ADF in ADCSR_1

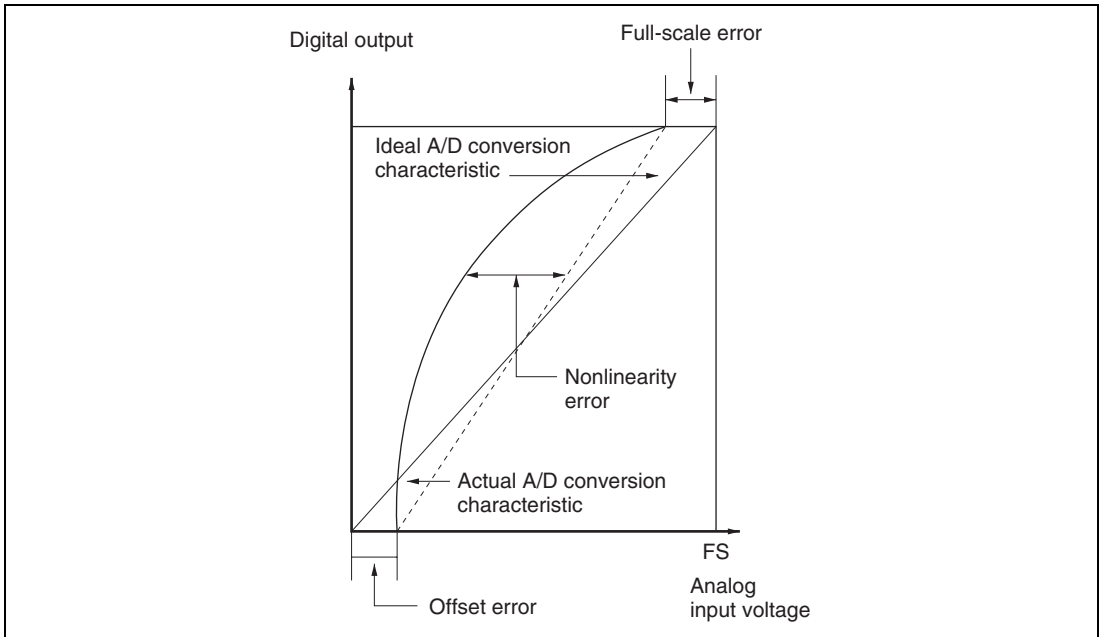
## 13.6 Definitions of A/D Conversion Accuracy

This LSI's A/D conversion accuracy definitions are given below.

- **Resolution**  
The number of A/D converter digital output codes
- **Quantization error**  
The deviation inherent in the A/D converter, given by 1/2 LSB (see figure 13.5).
- **Offset error**  
The deviation of the analog input voltage value from the ideal A/D conversion characteristic when the digital output changes from the minimum voltage value B'000000000 (H'000) to B'000000001 (H'001) (see figure 13.6).
- **Full-scale error**  
The deviation of the analog input voltage value from the ideal A/D conversion characteristic when the digital output changes from B'111111110 (H'3FE) to B'111111111 (H'3FF) (see figure 13.6).
- **Nonlinearity error**  
The error with respect to the ideal A/D conversion characteristic between zero voltage and full-scale voltage. Does not include offset error, full-scale error, or quantization error (see figure 13.6).
- **Absolute accuracy**  
The deviation between the digital value and the analog input value. Includes offset error, full-scale error, quantization error, and nonlinearity error.



**Figure 13.5** Definitions of A/D Conversion Accuracy



**Figure 13.6 Definitions of A/D Conversion Accuracy**

## 13.7 Usage Notes

### 13.7.1 Module Standby Mode Setting

Operation of the A/D converter can be disabled or enabled using the standby control register. The initial setting is for operation of the A/D converter to be halted. Register access is enabled by clearing module standby mode. For details, refer to section 19, Power-Down Modes.

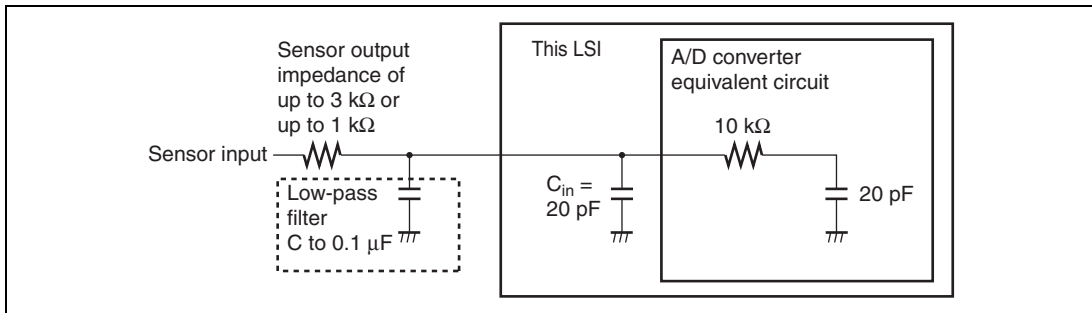
### 13.7.2 Permissible Signal Source Impedance

This LSI's analog input is designed such that conversion accuracy is guaranteed for an input signal for which the signal source impedance is 1 k $\Omega$  or less. This specification is provided to enable the A/D converter's sample-and-hold circuit input capacitance to be charged within the sampling time; if the sensor output impedance exceeds 1 k $\Omega$ , charging may be insufficient and it may not be possible to guarantee A/D conversion accuracy. However, for A/D conversion in single mode with a large capacitance provided externally, the input load will essentially comprise only the internal input resistance of 10 k $\Omega$ , and the signal source impedance is ignored. However, as a low-pass filter effect is obtained in this case, it may not be possible to follow an analog signal with a large differential coefficient (e.g., 5 mV/ $\mu$ s or greater) (see figure 13.7). When converting a high-speed analog signal or converting in scan mode, a low-impedance buffer should be inserted.

### 13.7.3 Influences on Absolute Accuracy

Adding capacitance results in coupling with GND, and therefore noise in GND may adversely affect absolute precision. Be sure to make the connection to an electrically stable GND such as AVss.

Care is also required to insure that filter circuits do not interfere in the accuracy by the printed circuit digital signals on the mounting board (i.e, acting as antennas).



**Figure 13.7 Example of Analog Input Circuit**

### 13.7.4 Range of Analog Power Supply and Other Pin Settings

If the conditions below are not met, the reliability of the device may be adversely affected.

- Analog input voltage range  
The voltage applied to analog input pin AN<sub>n</sub> during A/D conversion should be in the range  $AV_{SS} \leq V_{AN} \leq AV_{ref}$ .
- Relationship between AV<sub>cc</sub>, AV<sub>ss</sub> and V<sub>cc</sub>, V<sub>ss</sub>  
Set  $AV_{SS} = V_{SS}$  for the relationship between AV<sub>cc</sub>, AV<sub>ss</sub> and V<sub>cc</sub>, V<sub>ss</sub>. If the A/D converter is not used, the AV<sub>cc</sub> and AV<sub>ss</sub> pins must not be left open.

### 13.7.5 Notes on Board Design

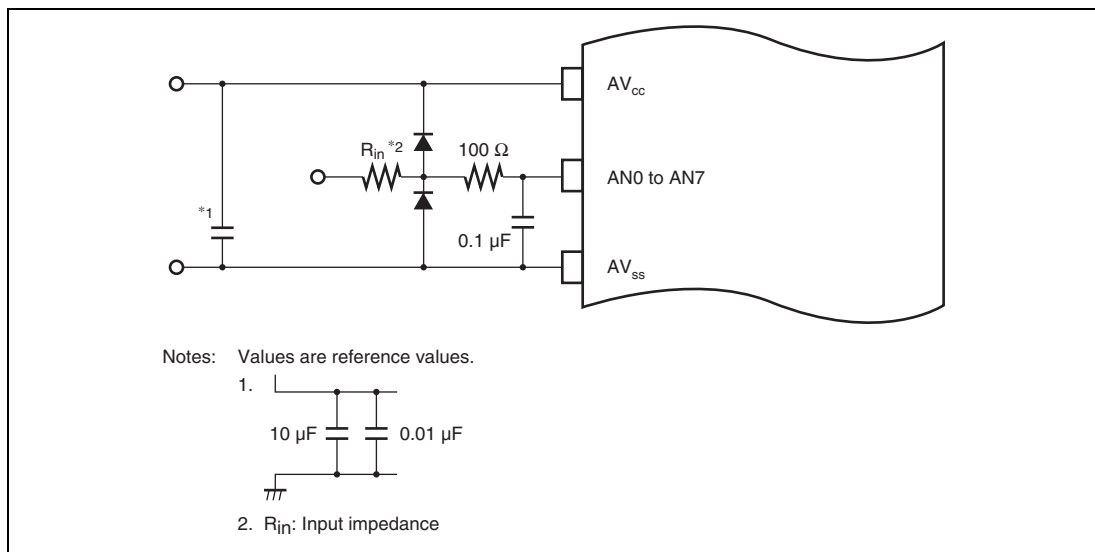
In board design, digital circuitry and analog circuitry should be as mutually isolated as possible, and layout in which digital circuit signal lines and analog circuit signal lines cross or are in close proximity should be avoided as far as possible. Failure to do so may result in incorrect operation of the analog circuitry due to inductance, adversely affecting A/D conversion values. Also, digital circuitry must be isolated from the analog input signals (AN0 to AN7), and analog power supply (AV<sub>cc</sub>) by the analog ground (AV<sub>ss</sub>). Also, the analog ground (AV<sub>ss</sub>) should be connected at one point to a stable ground (V<sub>ss</sub>) on the board.



### 13.7.6 Notes on Noise Countermeasures

A protection circuit should be connected in order to prevent damage due to abnormal voltage, such as an excessive surge at the analog input pins (AN0 to AN7), between AVcc and AVss, as shown in figure 13.8. Also, the bypass capacitors connected to AVcc and the filter capacitor connected to AN0 to AN7 must be connected to AVss.

If a filter capacitor is connected, the input currents at the analog input pins (AN0 to AN7) are averaged, and so an error may arise. Also, when A/D conversion is performed frequently, as in scan mode, if the current charged and discharged by the capacitance of the sample-and-hold circuit in the A/D converter exceeds the current input via the input impedance ( $R_{in}$ ), an error will arise in the analog input pin voltage. Careful consideration is therefore required when deciding circuit constants.



**Figure 13.8** Example of Analog Input Protection Circuit

**Table 13.7** Analog Pin Specifications

Item	Min.	Max.	Unit	Condition
Analog input capacitance	—	20	pF	—
Permissible signal source impedance	—	3	k $\Omega$	Conversion time $\geq 4.0 \mu\text{s}$
	—	1	k $\Omega$	Conversion time $< 4.0 \mu\text{s}$



## Section 14 Compare Match Timer (CMT)

This LSI has an on-chip compare match timer (CMT) consisting of a 2-channel 16-bit timer. The CMT has a 16-bit counter, and can generate interrupts at set intervals.

### 14.1 Features

- Selection of four counter input clocks  
Any of four internal clocks ( $P\phi/8$ ,  $P\phi/32$ ,  $P\phi/128$ , and  $P\phi/512$ ) can be selected independently for each channel.
- Interrupt request on compare match
- Module standby mode can be set.

Figure 14.1 shows a block diagram of CMT.

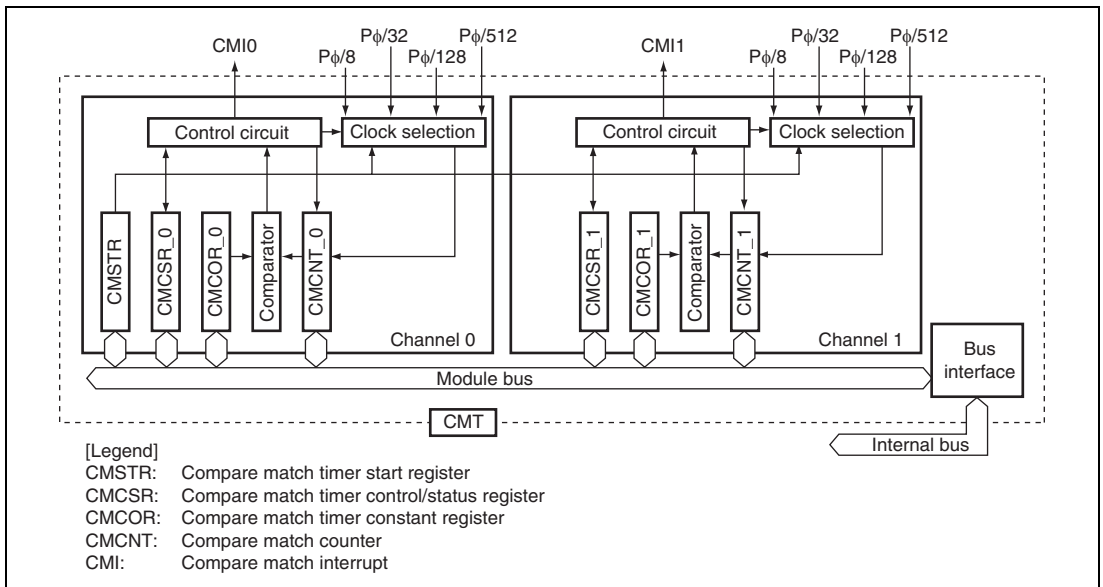


Figure 14.1 Block Diagram of CMT

## 14.2 Register Descriptions

The CMT has the following registers. For details on register addresses and register states during each processing, refer to section 20, List of Registers. Note that the channel number is omitted from the register name in this section.

**Table 14.1 Register Configuration**

Register Name	Abbreviation	R/W	Initial Value	Address	Access Size
Compare match timer start register	CMSTR	R/W	H'0000	H'FFFFFFE00	8, 16, 32
Compare match timer control/status register_0	CMCSR_0	R/W	H'0000	H'FFFFFFE02	8, 16
Compare match counter_0	CMCNT_0	R/W	H'0000	H'FFFFFFE04	8, 16, 32
Compare match constant register_0	CMCOR_0	R/W	H'FFFF	H'FFFFFFE06	8, 16
Compare match timer control/status register_1	CMCSR_1	R/W	H'0000	H'FFFFFFE08	8, 16, 32
Compare match counter_1	CMCNT_1	R/W	H'0000	H'FFFFFFE0A	8, 16
Compare match constant register_1	CMCOR_1	R/W	H'FFFF	H'FFFFFFE0C	8, 16, 32

### 14.2.1 Compare Match Timer Start Register (CMSTR)

CMSTR is a 16-bit register that selects whether compare match counter (CMCNT) operates or is stopped.

Bit:	15	14	13	12	11	10	9	8	7	6	5	4	3	2	1	0
	-	-	-	-	-	-	-	-	-	-	-	-	-	-	STR1	STR0
Initial value:	0	0	0	0	0	0	0	0	0	0	0	0	0	0	0	0
R/W:	R	R	R	R	R	R	R	R	R	R	R	R	R	R	R/W	R/W

Bit	Bit Name	Initial value	R/W	Description
15 to 2	—	All 0	R	Reserved These bits are always read as 0. The write value should always be 0.
1	STR1	0	R/W	Count Start 1 Specifies whether compare match counter 1 operates or is stopped. 0: CMCNT_1 count is stopped 1: CMCNT_1 count is started
0	STR0	0	R/W	Count Start 0 Specifies whether compare match counter 0 operates or is stopped. 0: CMCNT_0 count is stopped 1: CMCNT_0 count is started

### 14.2.2 Compare Match Timer Control/Status Register (CMCSR)

CMCSR is a 16-bit register that indicates compare match generation, enables interrupts and selects the counter input clock.

Bit:	15	14	13	12	11	10	9	8	7	6	5	4	3	2	1	0
	-	-	-	-	-	-	-	-	CMF	CMIE	-	-	-	-	-	CKS[1:0]
Initial value:	0	0	0	0	0	0	0	0	0	0	0	0	0	0	0	0
R/W:	R	R	R	R	R	R	R	R	(R/W)*1	R/W	R	R	R	R	R/W	R/W

Note: 1. Writing 0 to this bit after reading it as 1 clears the flag and is the only allowed way.

Bit	Bit Name	Initial value	R/W	Description
15 to 8	—	All 0	R	Reserved These bits are always read as 0. The write value should always be 0.
7	CMF	0	R/(W)* <sup>1</sup>	Compare Match Flag Indicates whether or not the values of CMCNT and CMCOR match. 0: CMCNT and CMCOR values do not match [Clearing condition] <ul style="list-style-type: none"> <li>When 0 is written to this bit after reading CMF = 1*<sup>2</sup></li> </ul> [Setting condition] 1: CMCNT and CMCOR values match
6	CMIE	0	R/W	Compare Match Interrupt Enable Enables or disables compare match interrupt (CMI) generation when CMCNT and CMCOR values match (CMF=1). 0: Compare match interrupt (CMI) disabled 1: Compare match interrupt (CMI) enabled
5 to 2	—	All 0	R	Reserved These bits are always read as 0. The write value should always be 0.
1, 0	CKS[1:0]	00	R/W	Clock Select 1 and 0 Select the clock to be input to CMCNT from four internal clocks obtained by dividing the peripheral operating clock (P $\phi$ ). When the STR bit in CMSTR is set to 1, CMCNT starts counting on the clock selected with bits CKS1 and CKS0. 00: P $\phi$ /8 01: P $\phi$ /32 10: P $\phi$ /128 11: P $\phi$ /512

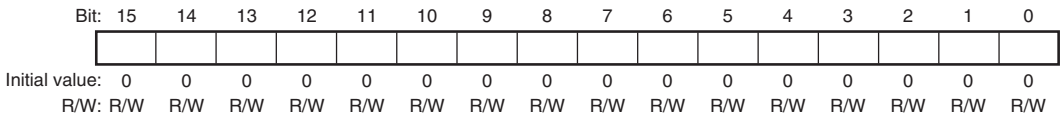
- Notes:
- Writing 0 to this bit after reading it as 1 clears the flag and is the only allowed way.
  - If another flag setting condition occurs before writing 0 to the bit after reading it as 1, the flag will not be cleared by simply writing 0 to it. In this case, read the bit as 1 once again and write 0 to it.

### 14.2.3 Compare Match Counter (CMCNT)

CMCNT is a 16-bit register used as an up-counter. When the counter input clock is selected with bits CKS1 and CKS0 in CMCSR and the STR bit in CMSTR is set to 1, CMCNT starts counting using the selected clock.

When the value in CMCNT and the value in compare match constant register (CMCOR) match, CMCNT is cleared to H'0000 and the CMF flag in CMCSR is set to 1.

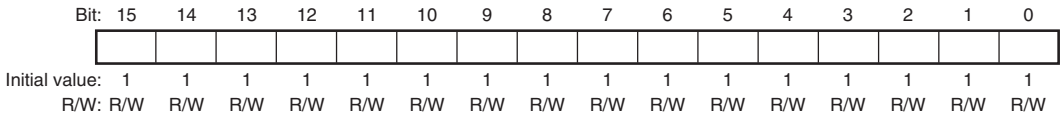
The initial value of CMCNT is H'0000.



### 14.2.4 Compare Match Constant Register (CMCOR)

CMCOR is a 16-bit register that sets the interval up to a compare match with CMCNT.

The initial value of CMCOR is H'FFFF.

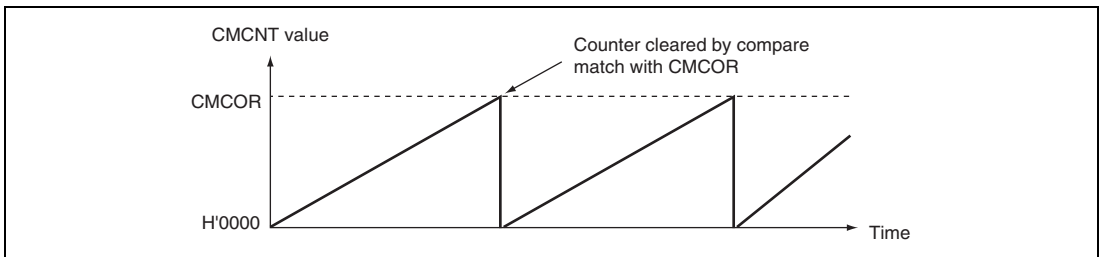


## 14.3 Operation

### 14.3.1 Interval Count Operation

When an internal clock is selected with bits CKS1 and CKS0 in CMCSR and the STR bit in CMSTR is set to 1, CMCNT starts incrementing using the selected clock. When the values in CMCNT and CMCOR match, CMCNT is cleared to H'0000 and the CMF flag in CMCSR is set to 1. When the CMIE bit in CMCSR is set to 1, a compare match interrupt (CMI) is requested. CMCNT then starts counting up again from H'0000.

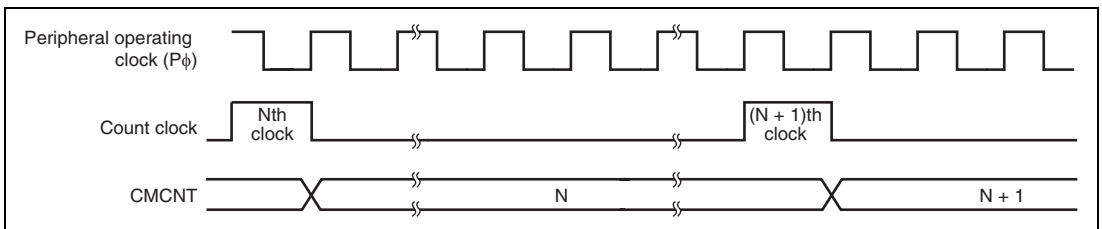
Figure 14.2 shows the operation of the compare match counter.



**Figure 14.2 Counter Operation**

### 14.3.2 CMCNT Count Timing

One of four internal clocks ( $P\phi/8$ ,  $P\phi/32$ ,  $P\phi/128$ , and  $P\phi/512$ ) obtained by dividing the  $P\phi$  clock can be selected with bits CKS1 and CKS0 in CMCSR. Figure 14.3 shows the timing.



**Figure 14.3 Count Timing**



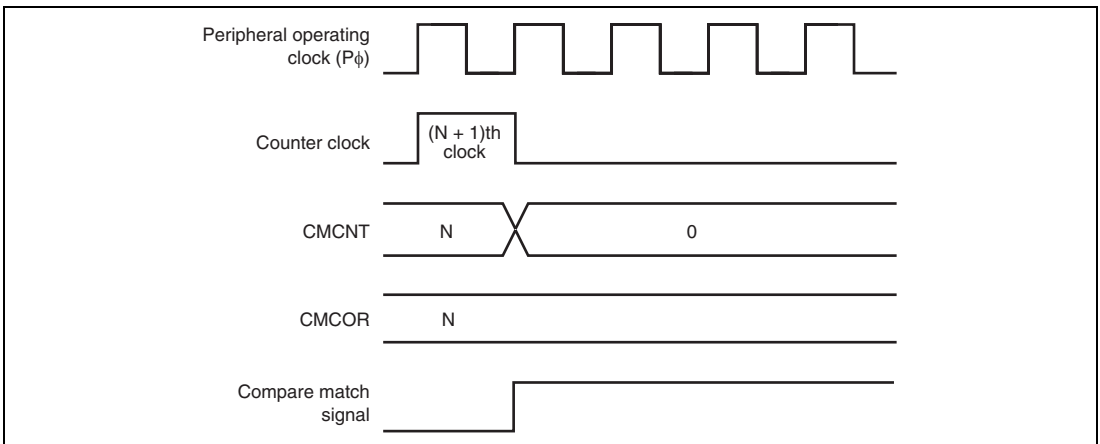
## 14.4 Interrupts

### 14.4.1 CMT Interrupt Sources

The CMT has channels and each of them to which a different vector address is allocated has compare match interrupt. When both the interrupt request flag (CMF) and interrupt enable bit (CMIE) are set to 1, the corresponding interrupt request is output. When the interrupt is used to activate a CPU interrupt, the priority of channels can be changed by the interrupt controller settings. For details, see section 6, Interrupt Controller (INTC).

### 14.4.2 Timing of Setting Compare Match Flag

When CMCOR and CMCNT match, a compare match signal is generated and the CMF bit in CMCSR is set to 1. The compare match signal is generated in the last cycle in which the values match (when the CMCNT value is updated to H'0000). That is, after a match between CMCOR and CMCNT, the compare match signal is not generated until the next CMCNT counter clock input. Figure 14.4 shows the timing of CMF bit setting.



**Figure 14.4 Timing of CMF Setting**

### 14.4.3 Timing of Clearing Compare Match Flag

The CMF bit in CMCSR is cleared by reading 1 from this bit, then writing 0.

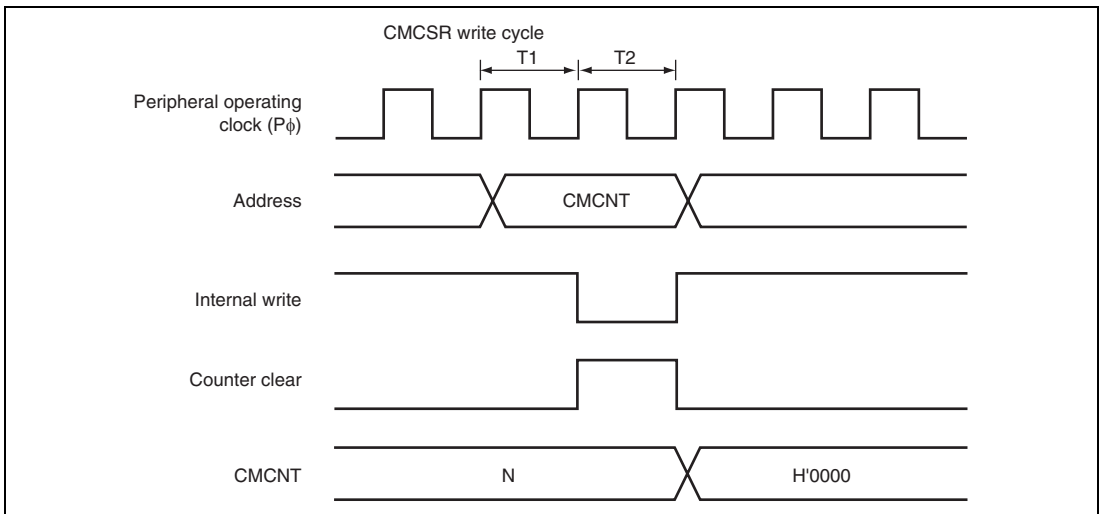
## 14.5 Usage Notes

### 14.5.1 Module Standby Mode Setting

The CMT operation can be disabled or enabled using the standby control register. The initial setting is for CMT operation to be halted. Access to a register is enabled by clearing module standby mode. For details, refer to section 19, Power-Down Modes.

### 14.5.2 Conflict between Write and Compare-Match Processes of CMCNT

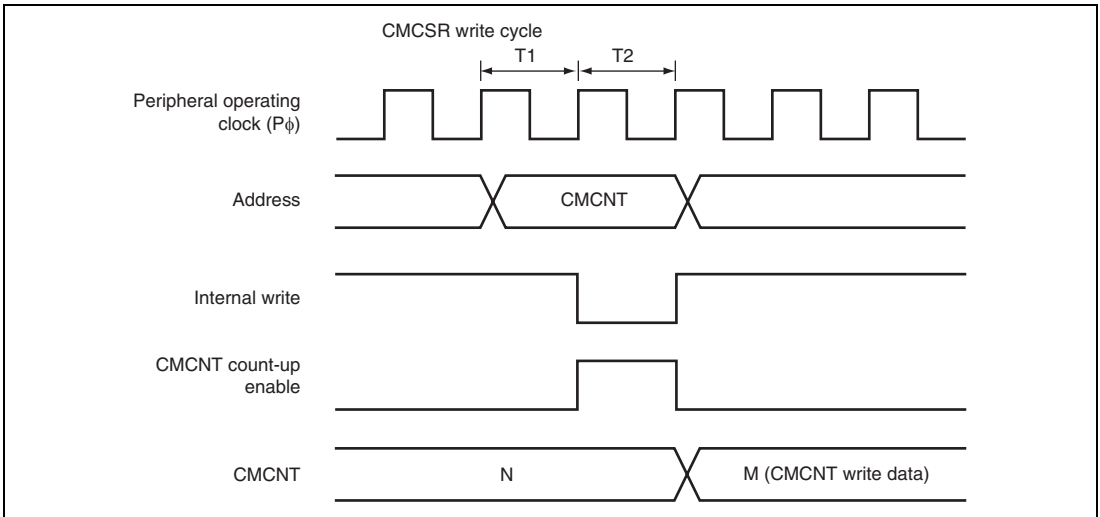
When the compare match signal is generated in the T2 cycle while writing to CMCNT, clearing CMCNT has priority over writing to it. In this case, CMCNT is not written to. Figure 14.5 shows the timing to clear the CMCNT counter.



**Figure 14.5 Conflict between Write and Compare-Match Processes of CMCNT**

### 14.5.3 Conflict between Word-Write and Count-Up Processes of CMCNT

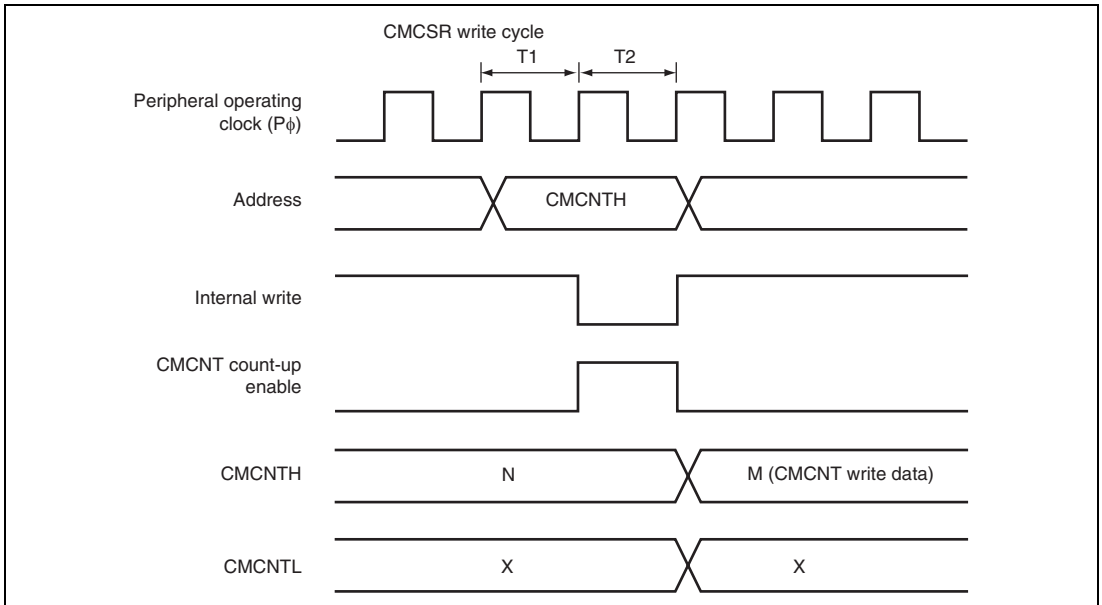
Even when the count-up occurs in the T2 cycle while writing to CMCNT in words, the writing has priority over the count-up. In this case, the count-up is not performed. Figure 14.6 shows the timing to write to CMCNT in words.



**Figure 14.6 Conflict between Word-Write and Count-Up Processes of CMCNT**

#### 14.5.4 Conflict between Byte-Write and Count-Up Processes of CMCNT

Even when the count-up occurs in the T2 cycle while writing to CMCNT in bytes, the byte-writing has priority over the count-up. In this case, the count-up is not performed. The byte data on another side, which is not written to, is also not counted and the previous contents remain. Figure 14.7 shows the timing when the count-up occurs in the T2 cycle while writing to CMCNT in bytes.



**Figure 14.7 Conflict between Byte-Write and Count-Up Processes of CMCNT**

#### 14.5.5 Compare Match between CMCNT and CMCOR

Do not set the same value in CMCNT and CMCOR while CMCNT is not counting. If set, the CMF bit in CMCSR is set to 1 and CMCNT is cleared to H'0000.

## Section 15 Pin Function Controller (PFC)

The pin function controller (PFC) is composed of registers that are used to select the functions of multiplexed pins and assign pins to be inputs or outputs. Tables 15.1 and 15.2 list the multiplexed pins of this LSI.

Tables 15.3 and 15.4 list the pin functions in each operating mode.

**Table 15.1 SH7125 Multiplexed Pins**

Port	Function 1 (Related Module)	Function 2 (Related Module)	Function 3 (Related Module)	Function 4 (Related Module)	Function 5 (Related Module)
A	PA0 I/O (port)	POE0 input (POE)	RXD0 input (SCI)	—	—
	PA1 I/O (port)	$\overline{\text{POE1}}$ input (POE)	TXD0 output (SCI)	—	—
	PA2 I/O (port)	IRQ0 input (INTC)	SCK0 I/O (SCI)	—	—
	PA3 I/O (port)	IRQ1 input (INTC)	RXD1 input (SCI)	$\overline{\text{TRST}}$ input (H-UDI)	—
	PA4 I/O (port)	IRQ2 input (INTC)	TXD1 output (SCI)	TMS input (H-UDI)	—
	PA5 I/O (port)	IRQ3 input (INTC)	SCK1 I/O (SCI)	—	—
	PA6 I/O (port)	TCLKA input (MTU2)	—	—	—
	PA7 I/O (port)	TCLKB input (MTU2)	SCK2 I/O (SCI)	TCK input (H-UDI)	—
	PA8 I/O (port)	TCLKC input (MTU2)	RXD2 input (SCI)	TDI input (H-UDI)	—
	PA9 I/O (port)	TCLKD input (MTU2)	TXD2 output (SCI)	POE3 input (POE)	TDO output (H-UDI)
	PA10 I/O (port)	RXD0 input (SCI)	—	—	—
	PA11 I/O (port)	TXD0 output (SCI)	$\overline{\text{ADTRG}}$ input (A/D)	—	—
	PA12 I/O (port)	SCK0 I/O (SCI)	—	—	—
	PA13 I/O (port)	SCK1 I/O (SCI)	—	—	—
	PA14 I/O (port)	RXD1 input (SCI)	—	—	—
PA15 I/O (port)	TXD1 output (SCI)	—	—	—	
B	PB1 I/O (port)	TIC5W input (MTU2)	—	—	—
	PB2 I/O (port)	IRQ0 input (INTC)	POE0 input (POE)	—	—
	PB3 I/O (port)	IRQ1 input (INTC)	$\overline{\text{POE1}}$ input (POE)	TIC5V input (MTU2)	—
	PB5 I/O (port)	IRQ3 input (INTC)	TIC5U input (MTU2)	—	—
	PB16 I/O (port)	POE3 input (POE)	—	—	—

Port	Function 1 (Related Module)	Function 2 (Related Module)	Function 3 (Related Module)	Function 4 (Related Module)	Function 5 (Related Module)
E	PE0 I/O (port)	TIOC0A I/O (MTU2)	—	—	—
	PE1 I/O (port)	TIOC0B I/O (MTU2)	RXD0 input (SCI)	—	—
	PE2 I/O (port)	TIOC0C I/O (MTU2)	TXD0 output (SCI)	—	—
	PE3 I/O (port)	TIOC0D I/O (MTU2)	SCK0 I/O (SCI)	—	—
	PE4 I/O (port)	TIOC1A I/O (MTU2)	RXD1 input (SCI)	—	—
	PE5 I/O (port)	TIOC1B I/O (MTU2)	TXD1 output (SCI)	—	—
	PE6 I/O (port)	TIOC2A I/O (MTU2)	SCK1 I/O (SCI)	—	—
	PE7 I/O (port)	TIOC2B I/O (MTU2)	—	—	—
	PE8 I/O (port)	TIOC3A I/O (MTU2)	—	—	—
	PE9 I/O (port)	TIOC3B I/O (MTU2)	—	—	—
	PE10 I/O (port)	TIOC3C I/O (MTU2)	—	—	—
	PE11 I/O (port)	TIOC3D I/O (MTU2)	—	—	—
	PE12 I/O (port)	TIOC4A I/O (MTU2)	—	—	—
	PE13 I/O (port)	TIOC4B I/O (MTU2)	MRES input (INTC)	—	—
	PE14 I/O (port)	TIOC4C I/O (MTU2)	—	—	—
	PE15 I/O (port)	TIOC4D I/O (MTU2)	IRQOUT output (INTC)	—	—
F	PF0 input (port)	AN0 input (A/D)	—	—	—
	PF1 input (port)	AN1 input (A/D)	—	—	—
	PF2 input (port)	AN2 input (A/D)	—	—	—
	PF3 input (port)	AN3 input (A/D)	—	—	—
	PF4 input (port)	AN4 input (A/D)	—	—	—
	PF5 input (port)	AN5 input (A/D)	—	—	—
	PF6 input (port)	AN6 input (A/D)	—	—	—
	PF7 input (port)	AN7 input (A/D)	—	—	—

Note: During A/D conversion, the AN input function is enabled.

**Table 15.2 SH7124 Multiplexed Pins**

Port	Function 1 (Related Module)	Function 2 (Related Module)	Function 3 (Related Module)	Function 4 (Related Module)	Function 5 (Related Module)
A	PA0 I/O (port)	$\overline{\text{POE0}}$ input (POE)	RXD0 input (SCI)	—	—
	PA1 I/O (port)	$\overline{\text{POE1}}$ input (POE)	TXD0 output (SCI)	—	—
	PA3 I/O (port)	IRQ1 input (INTC)	RXD1 input (SCI)	$\overline{\text{TRST}}$ input (H-UDI)	—
	PA4 I/O (port)	IRQ2 input (INTC)	TXD1 output (SCI)	TMS input (H-UDI)	—
	PA6 I/O (port)	TCLKA input (MTU2)	—	—	—
	PA7 I/O (port)	TCLKB input (MTU2)	SCK2 I/O (SCI)	TCK input (H-UDI)	—
	PA8 I/O (port)	TCLKC input (MTU2)	RXD2 input (SCI)	TDI input (H-UDI)	—
	PA9 I/O (port)	TCLKD input (MTU2)	TXD2 output (SCI)	$\overline{\text{POE8}}$ input (POE)	TDO output (H-UDI)
	B	PB1 I/O (port)	TIC5W input (MTU2)	—	—
PB3 I/O (port)		IRQ1 input (INTC)	$\overline{\text{POE1}}$ input (POE)	TIC5V input (MTU2)	—
PB5 I/O (port)		IRQ3 input (INTC)	TIC5U input (MTU2)	—	—
E	PE0 I/O (port)	TIOC0A I/O (MTU2)	—	—	—
	PE1 I/O (port)	TIOC0B I/O (MTU2)	RXD0 input (SCI)	—	—
	PE2 I/O (port)	TIOC0C I/O (MTU2)	TXD0 output (SCI)	—	—
	PE3 I/O (port)	TIOC0D I/O (MTU2)	SCK0 I/O (SCI)	—	—
	PE8 I/O (port)	TIOC3A I/O (MTU2)	—	—	—
	PE9 I/O (port)	TIOC3B I/O (MTU2)	—	—	—
	PE10 I/O (port)	TIOC3C I/O (MTU2)	—	—	—
	PE11 I/O (port)	TIOC3D I/O (MTU2)	—	—	—
	PE12 I/O (port)	TIOC4A I/O (MTU2)	—	—	—
	PE13 I/O (port)	TIOC4B I/O (MTU2)	$\overline{\text{MRES}}$ input (INTC)	—	—
	PE14 I/O (port)	TIOC4C I/O (MTU2)	—	—	—
	PE15 I/O (port)	TIOC4D I/O (MTU2)	$\overline{\text{IRQOUT}}$ output (INTC)	—	—

<b>Port</b>	<b>Function 1 (Related Module)</b>	<b>Function 2 (Related Module)</b>	<b>Function 3 (Related Module)</b>	<b>Function 4 (Related Module)</b>	<b>Function 5 (Related Module)</b>
F	PF0 input (port)	AN0 input (A/D)	—	—	—
	PF1 input (port)	AN1 input (A/D)	—	—	—
	PF2 input (port)	AN2 input (A/D)	—	—	—
	PF3 input (port)	AN3 input (A/D)	—	—	—
	PF4 input (port)	AN4 input (A/D)	—	—	—
	PF5 input (port)	AN5 input (A/D)	—	—	—
	PF6 input (port)	AN6 input (A/D)	—	—	—
	PF7 input (port)	AN7 input (A/D)	—	—	—

Note: During A/D conversion, the AN input function is enabled.



**Table 15.3 SH7125 Pin Functions in Each Operating Mode**

Pin No.	Pin Name	
	Single-Chip Mode (MCU Mode 3)	
	Initial Function	PFC Selected Function Possibilities
4, 22, 35	Vcc	Vcc
6, 24, 33	Vss	Vss
8, 37	VCL	VCL
61	AVcc	AVcc
52	AVss	AVss
47	PLLVss	PLLVss
42	EXTAL	EXTAL
41	XTAL	XTAL
46	MD1	MD1
45	FWE/( $\overline{\text{ASEBRKAK}}$ / $\overline{\text{ASEBRK}}$ *)	FWE
39	$\overline{\text{RES}}$	$\overline{\text{RES}}$
40	$\overline{\text{WDTOVF}}$	$\overline{\text{WDTOVF}}$
44	NMI	NMI
43	$\overline{\text{ASEMD0}}$	$\overline{\text{ASEMD0}}$
38	PA0	PA0/POE0/RXD0
36	PA1	PA1/POE1/TXD0
34	PA2	PA2/IRQ0/SCK0
32	PA3/( $\overline{\text{TRST}}$ *)	PA3/IRQ1/RXD1
31	PA4/(TMS*)	PA4/IRQ2/TXD1
30	PA5	PA5/IRQ3/SCK1
29	PA6	PA6/TCLKA
28	PA7/(TCK*)	PA7/TCLKB/SCK2
27	PA8/(TDI*)	PA8/TCLKC/RXD2
26	PA9/(TDO*)	PA9/TCLKD/TXD2/POE8
25	PA10	PA10/RXD0
23	PA11	PA11/TXD0/ $\overline{\text{ADTRG}}$
21	PA12	PA12/SCK0
20	PA13	PA13/SCK1

## Pin Name

## Single-Chip Mode (MCU Mode 3)

Pin No.	Initial Function	PFC Selected Function Possibilities
19	PA14	PA14/RXD1
18	PA15	PA15/TXD1
51	PB1	PB1/TIC5W
50	PB2	PB2/IRQ0/ $\overline{POE0}$
49	PB3	PB3/IRQ1/ $\overline{POE1}$ /TIC5V
48	PB5	PB5/IRQ3/TIC5U
62	$\overline{POE3}$	PB16/ $\overline{POE3}$
17	PE0	PE0/TIOC0A
16	PE1	PE1/TIOC0B/RXD0
15	PE2	PE2/TIOC0C/TXD0
14	PE3	PE3/TIOC0D/SCK0
13	PE4	PE4/TIOC1A/RXD1
12	PE5	PE5/TIOC1B/TXD1
11	PE6	PE6/TIOC2A/SCK1
10	PE7	PE7/TIOC2B
9	PE8	PE8/TIOC3A
5	PE9	PE9/TIOC3B
7	PE10	PE10/TIOC3C
3	PE11	PE11/TIOC3D
2	PE12	PE12/TIOC4A
1	PE13	PE13/TIOC4B/ $\overline{MRES}$
64	PE14	PE14/TIOC4C
63	PE15	PE15/TIOC4D/ $\overline{IRQOUT}$
60	PF0/AN0	PF0/AN0
59	PF1/AN1	PF1/AN1
58	PF2/AN2	PF2/AN2
57	PF3/AN3	PF3/AN3
56	PF4/AN4	PF4/AN4
55	PF5/AN5	PF5/AN5

Pin Name		
Single-Chip Mode (MCU Mode 3)		
Pin No.	Initial Function	PFC Selected Function Possibilities
54	PF6/AN6	PF6/AN6
53	PF7/AN7	PF7/AN7

Note: \* Fixed to TMS,  $\overline{\text{TRST}}$ , TDI, TDO, TCK, and  $\overline{\text{ASEBRKAK/ASEBRK}}$  when using the E10A (in  $\overline{\text{ASEMD0}}$  = low).

**Table 15.4 SH7124 Pin Functions in Each Operating Mode**

Pin Name		
Single-Chip Mode (MCU Mode 3)		
Pin No.	Initial Function	PFC Selected Function Possibilities
4, 17	Vcc	Vcc
6, 19	Vss	Vss
8, 25	VCL	VCL
48	AVcc	AVcc
39	AVss	AVss
35	PLLVss	PLLVss
30	EXTAL	EXTAL
29	XTAL	XTAL
34	MD1	MD1
33	$\overline{\text{FWE/ASEBRKAK/ASEBRK}}$ *	FWE
27	$\overline{\text{RES}}$	$\overline{\text{RES}}$
28	$\overline{\text{WDTOVF}}$	$\overline{\text{WDTOVF}}$
32	NMI	NMI
31	$\overline{\text{ASEMD0}}$	$\overline{\text{ASEMD0}}$
26	PA0	PA0/POE0/RXD0
24	PA1	PA1/POE1/TXD0
23	PA3/ $\overline{\text{TRST}}$ *	PA3/IRQ1/RXD1
22	PA4/(TMS*)	PA4/IRQ2/TXD1
21	PA6	PA6/TCLKA
20	PA7/(TCK*)	PA7/TCLKB/SCK2

Pin Name		
Single-Chip Mode (MCU Mode 3)		
Pin No.	Initial Function	PFC Selected Function Possibilities
18	PA8/(TDI*)	PA8/TCLKC/RXD2
16	PA9/(TDO*)	PA9/TCLKD/TXD2/ $\overline{POE8}$
38	PB1	PB1/TIC5W
37	PB3	PB3/IRQ1/ $\overline{POE1}$ /TIC5V
36	PB5	PB5/IRQ3/TIC5U
15	PE0	PE0/TIOC0A
14	PE1	PE1/TIOC0B/RXD0
13	PE2	PE2/TIOC0C/TXD0
12	PE3	PE3/TIOC0D/SCK0
11	PE8	PE8/TIOC3A
9	PE9	PE9/TIOC3B
10	PE10	PE10/TIOC3C
7	PE11	PE11/TIOC3D
5	PE12	PE12/TIOC4A
3	PE13	PE13/TIOC4B/ $\overline{MRES}$
2	PE14	PE14/TIOC4C
1	PE15	PE15/TIOC4D/IRQOUT
47	PF0/AN0	PF0/AN0
46	PF1/AN1	PF1/AN1
45	PF2/AN2	PF2/AN2
44	PF3/AN3	PF3/AN3
43	PF4/AN4	PF4/AN4
42	PF5/AN5	PF5/AN5
41	PF6/AN6	PF6/AN6
40	PF7/AN7	PF7/AN7

Note: \* Fixed to TMS, TRST, TDI, TDO, TCK, and ASEBRKAK/ASEBRK when using the E10A (in ASEMD0 = low).

## 15.1 Register Descriptions

The PFC has the following registers. For details on register addresses and register states in each processing state, refer to section 20, List of Registers.

**Table 15.5 Register Configuration**

Register Name	Abbrevia- tion	R/W	Initial Value	Address	Access Size
Port A I/O register L	PAIORL	R/W	H'0000	H'FFFFD106	8, 16
Port A control register L4	PACRL4	R/W	H'0000	H'FFFFD110	8, 16, 32
Port A control register L3	PACRL3	R/W	H'0000	H'FFFFD112	8, 16
Port A control register L2	PACRL2	R/W	H'0000	H'FFFFD114	8, 16, 32
Port A control register L1	PACRL1	R/W	H'0000	H'FFFFD116	8, 16
Port B I/O register H	PBIORH	R/W	H'0000	H'FFFFD184	8, 16, 32
Port B I/O register L	PBIORL	R/W	H'0000	H'FFFFD186	8, 16
Port B control register H1	PBCRH1	R/W	H'0000	H'FFFFD18E	8, 16
Port B control register L2	PBCRL2	R/W	H'0000	H'FFFFD194	8, 16, 32
Port B control register L1	PBCRL1	R/W	H'0000	H'FFFFD196	8, 16
Port E I/O register L	PEIORL	R/W	H'0000	H'FFFFD306	8, 16
Port E control register L4	PECRL4	R/W	H'0000	H'FFFFD310	8, 16, 32
Port E control register L3	PECRL3	R/W	H'0000	H'FFFFD312	8, 16
Port E control register L2	PECRL2	R/W	H'0000	H'FFFFD314	8, 16, 32
Port E control register L1	PECRL1	R/W	H'0000	H'FFFFD316	8, 16
IRQOUT function control register	IFCR	R/W	H'0000	H'FFFFD322	8, 16

### 15.1.1 Port A I/O Register L (PAIORL)

PAIORL is a 16-bit readable/writable register that is used to set the pins on port A as inputs or outputs. Bits PA15IOR to PA0IOR correspond to pins PA15 to PA0 (names of multiplexed pins are here given as port names and pin numbers alone). PAIORL is enabled when the port A pins are functioning as general-purpose inputs/outputs (PA15 to PA0). In other states, PAIORL is disabled.

A given pin on port A will be an output pin if the corresponding bit in PAIORL is set to 1, and an input pin if the bit is cleared to 0.

However, bits 15 to 10, 5, and 2 of PAIORL are disabled in SH7124.

The initial value of PAIORL is H'0000.

Bit:	15	14	13	12	11	10	9	8	7	6	5	4	3	2	1	0
	PA15 IOR	PA14 IOR	PA13 IOR	PA12 IOR	PA11 IOR	PA10 IOR	PA9 IOR	PA8 IOR	PA7 IOR	PA6 IOR	PA5 IOR	PA4 IOR	PA3 IOR	PA2 IOR	PA1 IOR	PA0 IOR
Initial value:	0	0	0	0	0	0	0	0	0	0	0	0	0	0	0	0
R/W:	R/W	R/W	R/W	R/W	R/W	R/W	R/W	R/W	R/W	R/W	R/W	R/W	R/W	R/W	R/W	R/W

### 15.1.2 Port A Control Registers L1 to L4 (PACRL1 to PACRL4)

PACRL1 to PACRL4 are 16-bit readable/writable registers that are used to select the functions of the multiplexed pins on port A.

#### SH7125:

- Port A Control Register L4 (PACRL4)

Bit:	15	14	13	12	11	10	9	8	7	6	5	4	3	2	1	0
	-	PA15 MD2	PA15 MD1	PA15 MD0	-	PA14 MD2	PA14 MD1	PA14 MD0	-	PA13 MD2	PA13 MD1	PA13 MD0	-	PA12 MD2	PA12 MD1	PA12 MD0
Initial value:	0	0	0	0	0	0	0	0	0	0	0	0	0	0	0	0
R/W:	R	R/W	R/W	R/W	R	R/W	R/W	R/W	R	R/W	R/W	R/W	R	R/W	R/W	R/W

Bit	Bit Name	Initial Value	R/W	Description
15	—	0	R	Reserved
				This bit is always read as 0. The write value should always be 0.

Bit	Bit Name	Initial Value	R/W	Description
14	PA15MD2	0	R/W	PA15 Mode
13	PA15MD1	0	R/W	Select the function of the PA15/TXD1 pin.
12	PA15MD0	0	R/W	000: PA15 I/O (port) 110: TXD1 output (SCI) Other than above: Setting prohibited
11	—	0	R	Reserved This bit is always read as 0. The write value should always be 0.
10	PA14MD2	0	R/W	PA14 Mode
9	PA14MD1	0	R/W	Select the function of the PA14/RXD1 pin.
8	PA14MD0	0	R/W	000: PA14 I/O (port) 110: RXD1 input (SCI) Other than above: Setting prohibited
7	—	0	R	Reserved This bit is always read as 0. The write value should always be 0.
6	PA13MD2	0	R/W	PA13 Mode
5	PA13MD1	0	R/W	Select the function of the PA13/SCK1 pin.
4	PA13MD0	0	R/W	000: PA13 I/O (port) 110: SCK1 I/O (SCI) Other than above: Setting prohibited
3	—	0	R	Reserved This bit is always read as 0. The write value should always be 0.
2	PA12MD2	0	R/W	PA12 Mode
1	PA12MD1	0	R/W	Select the function of the PA12/SCK0 pin.
0	PA12MD0	0	R/W	000: PA12 I/O (port) 110: SCK0 I/O (SCI) Other than above: Setting prohibited

- Port A Control Register L3 (PACRL3)

Bit:	15	14	13	12	11	10	9	8	7	6	5	4	3	2	1	0
	-	PA11 MD2	PA11 MD1	PA11 MD0	-	PA10 MD2	PA10 MD1	PA10 MD0	-	PA9 MD2	PA9 MD1	PA9 MD0	-	PA8 MD2	PA8 MD1	PA8 MD0
Initial value:	0	0	0	0	0	0	0	0	0	0	0	0	0	0	0	0
R/W:	R	R/W	R/W	R/W	R	R/W	R/W	R/W	R	R/W	R/W	R/W	R	R/W	R/W	R/W

Bit	Bit Name	Initial Value	R/W	Description
15	—	0	R	Reserved This bit is always read as 0. The write value should always be 0.
14	PA11MD2	0	R/W	PA11 Mode
13	PA11MD1	0	R/W	Select the function of the PA11/TXD0/ $\overline{\text{ADTRG}}$ pin.
12	PA11MD0	0	R/W	000: PA11 I/O (port) 010: $\overline{\text{ADTRG}}$ input (A/D) 110: TXD0 output (SCI) Other than above: Setting prohibited
11	—	0	R	Reserved This bit is always read as 0. The write value should always be 0.
10	PA10MD2	0	R/W	PA10 Mode
9	PA10MD1	0	R/W	Select the function of the PA10/RXD0 pin.
8	PA10MD0	0	R/W	000: PA10 I/O (port) 110: RXD0 input (SCI) Other than above: Setting prohibited
7	—	0	R	Reserved This bit is always read as 0. The write value should always be 0.



Bit	Bit Name	Initial Value	R/W	Description
6	PA9MD2	0	R/W	PA9 Mode
5	PA9MD1	0	R/W	Select the function of the PA9/TCLKD/TXD2/TDO/POE8 pin.
4	PA9MD0	0	R/W	When the E10A is in use ( $\overline{\text{ASEMD0}} = \text{low}$ ), function is fixed to TDO output. 000: PA9 I/O (port) 001: TCLKD input (MTU2) 110: TXD2 output (SCI) 111: POE8 input (POE) Other than above: Setting prohibited
3	—	0	R	Reserved This bit is always read as 0. The write value should always be 0.
2	PA8MD2	0	R/W	PA8 Mode
1	PA8MD1	0	R/W	Select the function of the PA8/TCLKC/RXD2/TDI pin.
0	PA8MD0	0	R/W	When the E10A is in use ( $\overline{\text{ASEMD0}} = \text{low}$ ), function is fixed to TDI input. 000: PA8 I/O (port) 001: TCLKC input (MTU2) 110: RXD2 input (SCI) Other than above: Setting prohibited

- Port A Control Register L2 (PACRL2)

Bit:	15	14	13	12	11	10	9	8	7	6	5	4	3	2	1	0
	-	PA7 MD2	PA7 MD1	PA7 MD0	-	PA6 MD2	PA6 MD1	PA6 MD0	-	PA5 MD2	PA5 MD1	PA5 MD0	-	PA4 MD2	PA4 MD1	PA4 MD0
Initial value:	0	0	0	0	0	0	0	0	0	0	0	0	0	0	0	0
R/W:	R	R/W	R/W	R/W	R	R/W	R/W	R/W	R	R/W	R/W	R/W	R	R/W	R/W	R/W

Bit	Bit Name	Initial Value	R/W	Description
15	—	0	R	Reserved This bit is always read as 0. The write value should always be 0.
14	PA7MD2	0	R/W	PA7 Mode
13	PA7MD1	0	R/W	Select the function of the PA7/TCLKB/SCK2/TCK pin.
12	PA7MD0	0	R/W	When the E10A is in use ( $\overline{ASEMD0}$ = low), function is fixed to TCK input. 000: PA7 I/O (port) 001: TCLKB input (MTU2) 110: SCK2 I/O (SCI) Other than above: Setting prohibited
11	—	0	R	Reserved This bit is always read as 0. The write value should always be 0.
10	PA6MD2	0	R/W	PA6 Mode
9	PA6MD1	0	R/W	Select the function of the PA6/TCLKA pin.
8	PA6MD0	0	R/W	000: PA6 I/O (port) 001: TCLKA input (MTU2) Other than above: Setting prohibited
7	—	0	R	Reserved This bit is always read as 0. The write value should always be 0.
6	PA5MD2	0	R/W	PA5 Mode
5	PA5MD1	0	R/W	Select the function of the PA5/IRQ3/SCK1 pin.
4	PA5MD0	0	R/W	000: PA5 I/O (port) 001: SCK1 I/O (SCI) 111: IRQ3 input (INTC) Other than above: Setting prohibited

Bit	Bit Name	Initial Value	R/W	Description
3	—	0	R	Reserved This bit is always read as 0. The write value should always be 0.
2	PA4MD2	0	R/W	PA4 Mode
1	PA4MD1	0	R/W	Select the function of the PA4/IRQ2/TXD1/TMS pin.
0	PA4MD0	0	R/W	When the E10A is in use (ASEMD0 = low), function is fixed to TCK input. 000: PA4 I/O (port) 001: TXD1 output (SCI) 111: IRQ2 input (INTC) Other than above: Setting prohibited

- Port A Control Register L1 (PACRL1)

Bit:	15	14	13	12	11	10	9	8	7	6	5	4	3	2	1	0
	-	PA3 MD2	PA3 MD1	PA3 MD0	-	PA2 MD2	PA2 MD1	PA2 MD0	-	PA1 MD2	PA1 MD1	PA1 MD0	-	PA0 MD2	PA0 MD1	PA0 MD0
Initial value:	0	0	0	0	0	0	0	0	0	0	0	0	0	0	0	0
R/W:	R	R/W	R/W	R/W	R	R/W	R/W	R/W	R	R/W	R/W	R/W	R	R/W	R/W	R/W

Bit	Bit Name	Initial Value	R/W	Description
15	—	0	R	Reserved This bit is always read as 0. The write value should always be 0.
14	PA3MD2	0	R/W	PA3 Mode
13	PA3MD1	0	R/W	Select the function of the PA3/IRQ1/RXD1/ $\overline{\text{TRST}}$ pin.
12	PA3MD0	0	R/W	When the E10A is in use (ASEMD0 = low), function is fixed to $\overline{\text{TRST}}$ input. 000: PA3 I/O (port) 001: RXD1 input (SCI) 111: IRQ1 input (INTC) Other than above: Setting prohibited
11	—	0	R	Reserved This bit is always read as 0. The write value should always be 0.

Bit	Bit Name	Initial Value	R/W	Description
10	PA2MD2	0	R/W	PA2 Mode
9	PA2MD1	0	R/W	Select the function of the PA2/IRQ0/SCK0 pin.
8	PA2MD0	0	R/W	000: PA2 I/O (port) 001: SCK0 I/O (SCI) 011: IRQ0 input (INTC) Other than above: Setting prohibited
7	—	0	R	Reserved This bit is always read as 0. The write value should always be 0.
6	PA1MD2	0	R/W	PA1 Mode
5	PA1MD1	0	R/W	Select the function of the PA1/ $\overline{\text{POE1}}$ /TXD0 pin.
4	PA1MD0	0	R/W	000: PA1 I/O (port) 001: TXD0 output (SCI) 111: $\overline{\text{POE1}}$ input (POE) Other than above: Setting prohibited
3	—	0	R	Reserved This bit is always read as 0. The write value should always be 0.
2	PA0MD2	0	R/W	PA0 Mode
1	PA0MD1	0	R/W	Select the function of the PA0/ $\overline{\text{POE0}}$ /RXD0 pin.
0	PA0MD0	0	R/W	000: PA0 I/O (port) 001: RXD0 input (SCI) 111: $\overline{\text{POE0}}$ input (POE) Other than above: Setting prohibited

**SH7124:**

## • Port A Control Register L4 (PACRL4)

Bit:	15	14	13	12	11	10	9	8	7	6	5	4	3	2	1	0
	-	-	-	-	-	-	-	-	-	-	-	-	-	-	-	-
Initial value:	0	0	0	0	0	0	0	0	0	0	0	0	0	0	0	0
R/W:	R	R	R	R	R	R	R	R	R	R	R	R	R	R	R	R

Bit	Bit Name	Initial Value	R/W	Description
15 to 0	—	All 0	R	Reserved
These bits are always read as 0. The write value should always be 0.				

## • Port A Control Register L3 (PACRL3)

Bit:	15	14	13	12	11	10	9	8	7	6	5	4	3	2	1	0
	-	-	-	-	-	-	-	-	-	PA9 MD2	PA9 MD1	PA9 MD0	-	PA8 MD2	PA8 MD1	PA8 MD0
Initial value:	0	0	0	0	0	0	0	0	0	0	0	0	0	0	0	0
R/W:	R	R	R	R	R	R	R	R	R	R/W	R/W	R/W	R	R/W	R/W	R/W

Bit	Bit Name	Initial Value	R/W	Description
15 to 7	—	All 0	R	Reserved
These bits are always read as 0. The write value should always be 0.				
6	PA9MD2	0	R/W	PA9 Mode
5	PA9MD1	0	R/W	Select the function of the PA9/TCLKD/TXD2/TDO/POE8 pin. When the E10A is in use ( $\overline{ASEMD0}$ = low), function is fixed to TDO output.
4	PA9MD0	0	R/W	000: PA9 I/O (port) 001: TCLKD input (MTU2) 110: TXD2 output (SCI) 111: POE8 input (POE) Other than above: Setting prohibited
3	—	0	R	Reserved
This bit is always read as 0. The write value should always be 0.				

Bit	Bit Name	Initial Value	R/W	Description
2	PA8MD2	0	R/W	PA8 Mode
1	PA8MD1	0	R/W	Select the function of the PA8/TCLKC/RXD2/TDI pin.
0	PA8MD0	0	R/W	When the E10A is in use ( $\overline{ASEMD0}$ = low), function is fixed to TDI input.
				000: PA8 I/O (port)
				001: TCLKC input (MTU2)
				110: RXD2 input (SCI)
				Other than above: Setting prohibited

- Port A Control Register L2 (PACRL2)

Bit:	15	14	13	12	11	10	9	8	7	6	5	4	3	2	1	0
	-	PA7 MD2	PA7 MD1	PA7 MD0	-	PA6 MD2	PA6 MD1	PA6 MD0	-	-	-	-	-	PA4 MD2	PA4 MD1	PA4 MD0
Initial value:	0	0	0	0	0	0	0	0	0	0	0	0	0	0	0	0
R/W:	R	R/W	R/W	R/W	R	R/W	R/W	R/W	R	R	R	R	R	R/W	R/W	R/W

Bit	Bit Name	Initial Value	R/W	Description
15	—	0	R	Reserved
				This bit is always read as 0. The write value should always be 0.
14	PA7MD2	0	R/W	PA7 Mode
13	PA7MD1	0	R/W	Select the function of the PA7/TCLKB/SCK2/TCK pin.
12	PA7MD0	0	R/W	When the E10A is in use ( $\overline{ASEMD0}$ = low), function is fixed to TCK input.
				000: PA7 I/O (port)
				001: TCLKB input (MTU2)
				110: SCK2 I/O (SCI)
				Other than above: Setting prohibited
11	—	0	R	Reserved
				This bit is always read as 0. The write value should always be 0.

Bit	Bit Name	Initial Value	R/W	Description
10	PA6MD2	0	R/W	PA6 Mode
9	PA6MD1	0	R/W	Select the function of the PA6/TCLKA pin.
8	PA6MD0	0	R/W	000: PA6 I/O (port) 001: TCLKA input (MTU2) Other than above: Setting prohibited
7 to 3	—	All 0	R	Reserved These bits are always read as 0. The write value should always be 0.
2	PA4MD2	0	R/W	PA4 Mode
1	PA4MD1	0	R/W	Select the function of the PA4/IRQ2/TXD1/TMS pin.
0	PA4MD0	0	R/W	When the E10A is in use ( $\overline{\text{ASEMD0}} = \text{low}$ ), function is fixed to TMS input. 000: PA4 I/O (port) 001: TXD1 output (SCI) 111: IRQ2 input (INTC) Other than above: Setting prohibited

- Port A Control Register L1 (PACRL1)

Bit:	15	14	13	12	11	10	9	8	7	6	5	4	3	2	1	0
	-	PA3 MD2	PA3 MD1	PA3 MD0	-	-	-	-	-	PA1 MD2	PA1 MD1	PA1 MD0	-	PA0 MD2	PA0 MD1	PA0 MD0
Initial value:	0	0	0	0	0	0	0	0	0	0	0	0	0	0	0	0
R/W:	R	R/W	R/W	R/W	R	R	R	R	R	R/W	R/W	R/W	R	R/W	R/W	R/W

Bit	Bit Name	Initial Value	R/W	Description
15	—	0	R	Reserved This bit is always read as 0. The write value should always be 0.

Bit	Bit Name	Initial Value	R/W	Description
14	PA3MD2	0	R/W	PA3 Mode
13	PA3MD1	0	R/W	Select the function of the PA3/IRQ1/RXD1/ $\overline{\text{TRST}}$ pin.
12	PA3MD0	0	R/W	When the E10A is in use ( $\overline{\text{ASEMD0}} = \text{low}$ ), function is fixed to TRST input. 000: PA3 I/O (port) 001: RXD1 input (SCI) 111: IRQ1 input (INTC) Other than above: Setting prohibited
11 to 7	—	All 0	R	Reserved These bits are always read as 0. The write value should always be 0.
6	PA1MD2	0	R/W	PA1 Mode
5	PA1MD1	0	R/W	Select the function of the PA1/ $\overline{\text{POE1}}$ /TXD0 pin.
4	PA1MD0	0	R/W	000: PA1 I/O (port) 001: TXD0 output (SCI) 111: $\overline{\text{POE1}}$ input (POE) Other than above: Setting prohibited
3	—	0	R	Reserved This bit is always read as 0. The write value should always be 0.
2	PA0MD2	0	R/W	PA0 Mode
1	PA0MD1	0	R/W	Select the function of the PA0/ $\overline{\text{POE0}}$ /RXD0 pin.
0	PA0MD0	0	R/W	000: PA0 I/O (port) 001: RXD0 input (SCI) 100: $\overline{\text{POE0}}$ output (POE) Other than above: Setting prohibited



### 15.1.3 Port B I/O Registers L and H (PBIORL and PBIORH)

PBIORL and PBIORH are 16-bit readable/writable registers that are used to set the pins on port B as inputs or outputs. Bits PB16IOR, PB5IOR, and PB3IOR to PB1IOR correspond to pins PB16, PB5, and PB3 to PB1, respectively (names of multiplexed pins are here given as port names and pin numbers alone). PBIORL is enabled when the port B pins are functioning as general-purpose inputs/outputs (PB5 and PB3 to PB1), and the SCK pin is functioning as inputs/outputs of SCI. In other states, PBIORL is disabled. PBIORH is enabled when the port B pins are functioning as general-purpose inputs/outputs (PB16). In other states, PBIORH is disabled.

A given pin on port B will be an output pin if the corresponding bit in PBIORH or PBIORL is set to 1, and an input pin if the bit is cleared to 0.

However, bit 2 of PBIORL and bit 0 of PBIORH are disabled in SH7124.

Bits 15 to 6, 4, and 0 of PBIORL and bits 15 to 1 of PBIORH are reserved. These bits are always read as 0. The write value should always be 0.

The initial value of PBIORL and PBIORH are H'0000, respectively.

- Port B I/O Register H (PBIORH)

Bit:	15	14	13	12	11	10	9	8	7	6	5	4	3	2	1	0
	-	-	-	-	-	-	-	-	-	-	-	-	-	-	-	PB16 IOR
Initial value:	0	0	0	0	0	0	0	0	0	0	0	0	0	0	0	0
R/W:	R	R	R	R	R	R	R	R	R	R	R	R	R	R	R	R/W

- Port B I/O Register L (PBIORL)

Bit:	15	14	13	12	11	10	9	8	7	6	5	4	3	2	1	0
	-	-	-	-	-	-	-	-	-	-	PB5 IOR	-	PB3 IOR	PB2 IOR	PB1 IOR	-
Initial value:	0	0	0	0	0	0	0	0	0	0	0	0	0	0	0	0
R/W:	R	R	R	R	R	R	R	R	R	R	R/W	R	R/W	R/W	R/W	R

### 15.1.4 Port B Control Registers L1, L2, and H1 (PBCRL1, PBCRL2, and PBCRH1)

PBCRL1, PBCRL2, and PBCRH1 are 16-bit readable/writable registers that are used to select the function of the multiplexed pins on port B.

#### SH7125:

- Port B Control Register H1 (PBCRH1)

Bit:	15	14	13	12	11	10	9	8	7	6	5	4	3	2	1	0	
	-	-	-	-	-	-	-	-	-	-	-	-	-	-	-	-	PB16 MD
Initial value:	0	0	0	0	0	0	0	0	0	0	0	0	0	0	0	0	1
R/W:	R	R	R	R	R	R	R	R	R	R	R	R	R	R	R	R	R/W*

Note: \* After a power-on reset, write can be performed only once.

Bit	Bit Name	Initial Value	R/W	Description
15 to 1	—	All 0	R	Reserved These bits are always read as 0. The write value should always be 0.
0	PB16MD	1	R/W*	PB16 Mode Select the function of the PB16/ $\overline{\text{POE3}}$ pin. 0: PB16 I/O (port) 1: $\overline{\text{POE3}}$ input (POE)

- Port B Control Register L2 (PBCRL2)

Bit:	15	14	13	12	11	10	9	8	7	6	5	4	3	2	1	0	
	-	-	-	-	-	-	-	-	-	-	PB5 MD2	PB5 MD1	PB5 MD0	-	-	-	-
Initial value:	0	0	0	0	0	0	0	0	0	0	0	0	0	0	0	0	0
R/W:	R	R	R	R	R	R	R	R	R	R	R/W	R/W	R/W	R	R	R	R

Bit	Bit Name	Initial Value	R/W	Description
15 to 7	—	All 0	R	Reserved These bits are always read as 0. The write value should always be 0.

Bit	Bit Name	Initial Value	R/W	Description
6	PB5MD2	0	R/W	PB5 Mode
5	PB5MD1	0	R/W	Select the function of the PB5/IRQ3/TIC5U pin.
4	PB5MD0	0	R/W	000: PB5 I/O (port) 001: IRQ3 input (INTC) 011: TIC5U input (MTU2) Other than above: Setting prohibited
3 to 0	—	All 0	R	Reserved These bits are always read as 0. The write value should always be 0.

- Port B Control Register L1 (PBCRL1)

Bit:	15	14	13	12	11	10	9	8	7	6	5	4	3	2	1	0
	-	PB3 MD2	PB3 MD1	PB3 MD0	-	PB2 MD2	PB2 MD1	PB2 MD0	-	PB1 MD2	PB1 MD1	PB1 MD0	-	-	-	-
Initial value:	0	0	0	0	0	0	0	0	0	0	0	0	0	0	0	0
R/W:	R	R/W	R/W	R/W	R	R/W	R/W	R/W	R	R/W	R/W	R/W	R	R	R	R

Bit	Bit Name	Initial Value	R/W	Description
15	—	0	R	Reserved This bit is always read as 0. The write value should always be 0.
14	PB3MD2	0	R/W	PB3 Mode
13	PB3MD1	0	R/W	Select the function of the PB3/IRQ1/ $\overline{POE1}$ /TIC5V pin.
12	PB3MD0	0	R/W	000: PB3 I/O (port) 001: IRQ1 input (INTC) 010: $\overline{POE1}$ input (POE) 011: TIC5V input (MTU2) Other than above: Setting prohibited
11	—	0	R	Reserved This bit is always read as 0. The write value should always be 0.

Bit	Bit Name	Initial Value	R/W	Description
10	PB2MD2	0	R/W	PB2 Mode
9	PB2MD1	0	R/W	Select the function of the PB2/IRQ0/ $\overline{POE0}$ pin.
8	PB2MD0	0	R/W	000: PB2 I/O (port) 001: IRQ0 input (INTC) 010: $\overline{POE0}$ input (POE) Other than above: Setting prohibited
7	—	0	R	Reserved This bit is always read as 0. The write value should always be 0.
6	PB1MD2	0	R/W	PB1 Mode
5	PB1MD1	0	R/W	Select the function of the PB1/TIC5W pin.
4	PB1MD0	0	R/W	000: PB1 I/O (port) 011: TIC5W input (MTU2) Other than above: Setting prohibited
3 to 0	—	All 0	R	Reserved These bits are always read as 0. The write value should always be 0.

**SH7124:**

- Port B Control Register H1 (PBCRH1)

Bit:	15	14	13	12	11	10	9	8	7	6	5	4	3	2	1	0
	-	-	-	-	-	-	-	-	-	-	-	-	-	-	-	-
Initial value:	0	0	0	0	0	0	0	0	0	0	0	0	0	0	0	0
R/W:	R	R	R	R	R	R	R	R	R	R	R	R	R	R	R	R

Bit	Bit Name	Initial Value	R/W	Description
15 to 0	—	All 0	R	Reserved These bits are always read as 0. The write value should always be 0.

- Port B Control Register L2 (PBCRL2)

Bit:	15	14	13	12	11	10	9	8	7	6	5	4	3	2	1	0
	-	-	-	-	-	-	-	-	-	PB5 MD2	PB5 MD1	PB5 MD0	-	-	-	-
Initial value:	0	0	0	0	0	0	0	0	0	0	0	0	0	0	0	0
R/W:	R	R	R	R	R	R	R	R	R	R/W	R/W	R/W	R	R	R	R

Bit	Bit Name	Initial Value	R/W	Description
15 to 7	—	All 0	R	Reserved These bits are always read as 0. The write value should always be 0.
6	PB5MD2	0	R/W	PB5 Mode
5	PB5MD1	0	R/W	Select the function of the PB5/IRQ3/TIC5U pin.
4	PB5MD0	0	R/W	000: PB5 I/O (port) 001: IRQ3 input (INTC) 011: TIC5U input (MTU2) Other than above: Setting prohibited
3 to 0	—	All 0	R	Reserved These bits are always read as 0. The write value should always be 0.

- Port B Control Register L1 (PBCRL1)

Bit:	15	14	13	12	11	10	9	8	7	6	5	4	3	2	1	0
	-	PB3 MD2	PB3 MD1	PB3 MD0	-	-	-	-	-	PB1 MD2	PB1 MD1	PB1 MD0	-	-	-	-
Initial value:	0	0	0	0	0	0	0	0	0	0	0	0	0	0	0	0
R/W:	R	R/W	R/W	R/W	R	R	R	R	R	R/W	R/W	R/W	R	R	R	R

Bit	Bit Name	Initial Value	R/W	Description
15	—	0	R	Reserved This bit is always read as 0. The write value should always be 0.

Bit	Bit Name	Initial Value	R/W	Description
14	PB3MD2	0	R/W	PB3 Mode
13	PB3MD1	0	R/W	Select the function of the PB3/IRQ1/ $\overline{POE1}$ /TIC5V pin.
12	PB3MD0	0	R/W	000: PB3 I/O (port) 001: IRQ1 input (INTC) 010: $\overline{POE1}$ input (POE) 011: TIC5V input (MTU2) Other than above: Setting prohibited
11 to 7	—	All 0	R	Reserved These bits are always read as 0. The write value should always be 0.
6	PB1MD2	0	R/W	PB1 Mode
5	PB1MD1	0	R/W	Select the function of the PB1/TIC5W pin.
4	PB1MD0	0	R/W	000: PB1 I/O (port) 011: TIC5W input (MTU2) Other than above: Setting prohibited
3 to 0	—	All 0	R	Reserved These bits are always read as 0. The write value should always be 0.

### 15.1.5 Port E I/O Register L (PEIORL)

PEIORL is a 16-bit readable/writable register that is used to set the pins on port E as inputs or outputs. PE15IOR to PE0IOR correspond to pins PE15 to PE0 (names of multiplexed pins are here given as port names and pin numbers alone). PEIORL is enabled when the port E pins are functioning as general-purpose inputs/outputs (PE15 to PE0), and the TIOC pin is functioning as inputs/outputs of MTU2. In other states, PEIORL is disabled.

A given pin on port E will be an output pin if the corresponding bit in PEIORL is set to 1, and an input pin if the bit is cleared to 0.

However, bits 7 to 4 of PEIORL are disabled in SH7124.

The initial value of PEIORL is H'0000.

Bit:	15	14	13	12	11	10	9	8	7	6	5	4	3	2	1	0
	PE15 IOR	PE14 IOR	PE13 IOR	PE12 IOR	PE11 IOR	PE10 IOR	PE9 IOR	PE8 IOR	PE7 IOR	PE6 IOR	PE5 IOR	PE4 IOR	PE3 IOR	PE2 IOR	PE1 IOR	PE0 IOR
Initial value:	0	0	0	0	0	0	0	0	0	0	0	0	0	0	0	0
R/W:	R/W	R/W	R/W	R/W	R/W	R/W	R/W	R/W	R/W	R/W	R/W	R/W	R/W	R/W	R/W	R/W

### 15.1.6 Port E Control Registers L1 to L4 (PECRL1 to PECRL4)

PECRL1 to PECRL4, are 16-bit readable/writable registers that are used to select the functions of the multiplexed pins on port E.

#### SH7125:

- Port E Control Register L4 (PECRL4)

Bit:	15	14	13	12	11	10	9	8	7	6	5	4	3	2	1	0
	-	PE15 MD2	PE15 MD1	PE15 MD0	-	PE14 MD2	PE14 MD1	PE14 MD0	-	-	PE13 MD1	PE13 MD0	-	PE12 MD2	PE12 MD1	PE12 MD0
Initial value:	0	0	0	0	0	0	0	0	0	0	0	0	0	0	0	0
R/W:	R	R/W	R/W	R/W	R	R/W	R/W	R/W	R	R	R/W	R/W	R	R/W	R/W	R/W

Bit	Bit Name	Initial Value	R/W	Description
15	—	0	R	Reserved  This bit is always read as 0. The write value should always be 0.

Bit	Bit Name	Initial Value	R/W	Description
14	PE15MD2	0	R/W	PE15 Mode
13	PE15MD1	0	R/W	Select the function of the PE15/TIOC4D/ $\overline{\text{IRQOUT}}$ pin.
12	PE15MD0	0	R/W	000: PE15 I/O (port) 001: TIOC4D I/O (MTU2) 011: $\overline{\text{IRQOUT}}$ output (INTC) Other than above: Setting prohibited
11	—	0	R	Reserved This bit is always read as 0. The write value should always be 0.
10	PE14MD2	0	R/W	PE14 Mode
9	PE14MD1	0	R/W	Select the function of the PE14/TIOC4C pin.
8	PE14MD0	0	R/W	000: PE14 I/O (port) 001: TIOC4C I/O (MTU2) Other than above: Setting prohibited
7, 6	—	All 0	R	Reserved These bits are always read as 0. The write value should always be 0.
5	PE13MD1	0	R/W	PE13 Mode
4	PE13MD0	0	R/W	Select the function of the PE13/TIOC4B/ $\overline{\text{MRES}}$ pin. 00: PE13 I/O (port) 01: TIOC4B I/O (MTU2) 10: $\overline{\text{MRES}}$ input (INTC) Other than above: Setting prohibited
3	—	0	R	Reserved This bit is always read as 0. The write value should always be 0.
2	PE12MD2	0	R/W	PE12 Mode
1	PE12MD1	0	R/W	Select the function of the PE12/TIOC4A pin.
0	PE12MD0	0	R/W	000: PE12 I/O (port) 001: TIOC4A I/O (MTU2) Other than above: Setting prohibited



- Port E Control Register L3 (PECRL3)

Bit:	15	14	13	12	11	10	9	8	7	6	5	4	3	2	1	0
	-	PE11 MD2	PE11 MD1	PE11 MD0	-	PE10 MD2	PE10 MD1	PE10 MD0	-	PE9 MD2	PE9 MD1	PE9 MD0	-	PE8 MD2	PE8 MD1	PE8 MD0
Initial value:	0	0	0	0	0	0	0	0	0	0	0	0	0	0	0	0
R/W:	R	R/W	R/W	R/W	R	R/W	R/W	R/W	R	R/W	R/W	R/W	R	R/W	R/W	R/W

Bit	Bit Name	Initial Value	R/W	Description
15	—	0	R	Reserved This bit is always read as 0. The write value should always be 0.
14	PE11MD2	0	R/W	PE11 Mode
13	PE11MD1	0	R/W	Select the function of the PE11/TIOC3D pin.
12	PE11MD0	0	R/W	000: PE11 I/O (port) 001: TIOC3D I/O (MTU2) Other than above: Setting prohibited
11	—	0	R	Reserved This bit is always read as 0. The write value should always be 0.
10	PE10MD2	0	R/W	PE10 Mode
9	PE10MD1	0	R/W	Select the function of the PE10/TIOC3C pin.
8	PE10MD0	0	R/W	000: PE10 I/O (port) 001: TIOC3C I/O (MTU2) Other than above: Setting prohibited
7	—	0	R	Reserved This bit is always read as 0. The write value should always be 0.
6	PE9MD2	0	R/W	PE9 Mode
5	PE9MD1	0	R/W	Select the function of the PE9/TIOC3B pin.
4	PE9MD0	0	R/W	000: PE9 I/O (port) 001: TIOC3B I/O (MTU2) Other than above: Setting prohibited
3	—	0	R	Reserved This bit is always read as 0. The write value should always be 0.

Bit	Bit Name	Initial Value	R/W	Description
2	PE8MD2	0	R/W	PE8 Mode
1	PE8MD1	0	R/W	Select the function of the PE8/TIOC3A pin.
0	PE8MD0	0	R/W	000: PE8 I/O (port) 001: TIOC3A I/O (MTU2) Other than above: Setting prohibited

- Port E Control Register L2 (PECRL2)

Bit:	15	14	13	12	11	10	9	8	7	6	5	4	3	2	1	0
	-	PE7 MD2	PE7 MD1	PE7 MD0	-	PE6 MD2	PE6 MD1	PE6 MD0	-	PE5 MD2	PE5 MD1	PE5 MD0	-	PE4 MD2	PE4 MD1	PE4 MD0
Initial value:	0	0	0	0	0	0	0	0	0	0	0	0	0	0	0	0
R/W:	R	R/W	R/W	R/W	R	R/W	R/W	R/W	R	R/W	R/W	R/W	R	R/W	R/W	R/W

Bit	Bit Name	Initial Value	R/W	Description
15	—	0	R	Reserved This bit is always read as 0. The write value should always be 0.
14	PE7MD2	0	R/W	PE7 Mode
13	PE7MD1	0	R/W	Select the function of the PE7/TIOC2B pin.
12	PE7MD0	0	R/W	000: PE7 I/O (port) 001: TIOC2B I/O (MTU2) Other than above: Setting prohibited
11	—	0	R	Reserved This bit is always read as 0. The write value should always be 0.
10	PE6MD2	0	R/W	PE6 Mode
9	PE6MD1	0	R/W	Select the function of the PE6/TIOC2A/SCK1 pin.
8	PE6MD0	0	R/W	000: PE6 I/O (port) 001: TIOC2A I/O (MTU2) 110: SCK1 I/O (SCI) Other than above: Setting prohibited

Bit	Bit Name	Initial Value	R/W	Description
7	—	0	R	Reserved This bit is always read as 0. The write value should always be 0.
6	PE5MD2	0	R/W	PE5 Mode
5	PE5MD1	0	R/W	Select the function of the PE5/TIOC1B/TXD1 pin.
4	PE5MD0	0	R/W	000: PE5 I/O (port) 001: TIOC1B I/O (MTU2) 110: TXD1 output (SCI) Other than above: Setting prohibited
3	—	0	R	Reserved This bit is always read as 0. The write value should always be 0.
2	PE4MD2	0	R/W	PE4 Mode
1	PE4MD1	0	R/W	Select the function of the PE4/TIOC1A/RXD1 pin.
0	PE4MD0	0	R/W	000: PE4 I/O (port) 001: TIOC1A I/O (MTU2) 110: RXD1 input (SCI) Other than above: Setting prohibited

- Port E Control Register L1 (PECRL1)

Bit:	15	14	13	12	11	10	9	8	7	6	5	4	3	2	1	0
	-	PE3 MD2	PE3 MD1	PE3 MD0	-	PE2 MD2	PE2 MD1	PE2 MD0	-	PE1 MD2	PE1 MD1	PE1 MD0	-	-	PE0 MD1	PE0 MD0
Initial value:	0	0	0	0	0	0	0	0	0	0	0	0	0	0	0	0
R/W:	R	R/W	R/W	R/W	R	R/W	R/W	R/W	R	R/W	R/W	R/W	R	R	R/W	R/W

Bit	Bit Name	Initial Value	R/W	Description
15	—	0	R	Reserved This bit is always read as 0. The write value should always be 0.

Bit	Bit Name	Initial Value	R/W	Description
14	PE3MD2	0	R/W	PE3 Mode
13	PE3MD1	0	R/W	Select the function of the PE3/TIOC0D/SCK0 pin.
12	PE3MD0	0	R/W	000: PE3 I/O (port) 001: TIOC0D I/O (MTU2) 110: SCK0 I/O (SCI) Other than above: Setting prohibited
11	—	0	R	Reserved This bit is always read as 0. The write value should always be 0.
10	PE2MD2	0	R/W	PE2 Mode
9	PE2MD1	0	R/W	Select the function of the PE2/TIOC0C/TXD0 pin.
8	PE2MD0	0	R/W	000: PE2 I/O (port) 001: TIOC0C I/O (MTU2) 110: TXD0 output (SCI) Other than above: Setting prohibited
7	—	0	R	Reserved This bit is always read as 0. The write value should always be 0.
6	PE1MD2	0	R/W	PE1 Mode
5	PE1MD1	0	R/W	Select the function of the PE1/TIOC0B/RXD0 pin.
4	PE1MD0	0	R/W	000: PE1 I/O (port) 001: TIOC0B I/O (MTU2) 110: RXD0 input (SCI) Other than above: Setting prohibited
3, 2	—	All 0	R	Reserved These bits are always read as 0. The write value should always be 0.
1	PE0MD1	0	R/W	PE0 Mode
0	PE0MD0	0	R/W	Select the function of the PE0/TIOC0A pin. 00: PE0 I/O (port) 01: TIOC0A I/O (MTU2) Other than above: Setting prohibited

**SH7124:**

- Port E Control Register L4 (PECRL4)

Bit:	15	14	13	12	11	10	9	8	7	6	5	4	3	2	1	0
	-	PE15 MD2	PE15 MD1	PE15 MD0	-	PE14 MD2	PE14 MD1	PE14 MD0	-	-	PE13 MD1	PE13 MD0	-	PE12 MD2	PE12 MD1	PE12 MD0
Initial value:	0	0	0	0	0	0	0	0	0	0	0	0	0	0	0	0
R/W:	R	R/W	R/W	R/W	R	R/W	R/W	R/W	R	R	R/W	R/W	R	R/W	R/W	R/W

Bit	Bit Name	Initial Value	R/W	Description
15	—	0	R	Reserved This bit is always read as 0. The write value should always be 0.
14	PE15MD2	0	R/W	PE15 Mode
13	PE15MD1	0	R/W	Select the function of the PE15/TIOC4D/ $\overline{\text{IRQOUT}}$ pin.
12	PE15MD0	0	R/W	000: PE15 I/O (port) 001: TIOC4D I/O (MTU2) 011: $\overline{\text{IRQOUT}}$ output (INTC) Other than above: Setting prohibited
11	—	0	R	Reserved This bit is always read as 0. The write value should always be 0.
10	PE14MD2	0	R/W	PE14 Mode
9	PE14MD1	0	R/W	Select the function of the PE14/TIOC4C pin.
8	PE14MD0	0	R/W	000: PE14 I/O (port) 001: TIOC4C I/O (MTU2) Other than above: Setting prohibited
7, 6	—	All 0	R	Reserved These bits are always read as 0. The write value should always be 0.
5	PE13MD1	0	R/W	PE13 Mode
4	PE13MD0	0	R/W	Select the function of the PE13/TIOC4B/ $\overline{\text{MRES}}$ pin. 00: PE13 I/O (port) 01: TIOC4B I/O (MTU2) 10: $\overline{\text{MRES}}$ input (INTC) Other than above: Setting prohibited

Bit	Bit Name	Initial Value	R/W	Description
3	—	0	R	Reserved This bit is always read as 0. The write value should always be 0.
2	PE12MD2	0	R/W	PE12 Mode
1	PE12MD1	0	R/W	Select the function of the PE12/TIOC4A pin.
0	PE12MD0	0	R/W	000: PE12 I/O (port) 001: TIOC4A I/O (MTU2) Other than above: Setting prohibited

- Port E Control Register L3 (PECRL3)

Bit:	15	14	13	12	11	10	9	8	7	6	5	4	3	2	1	0
	-	PE11 MD2	PE11 MD1	PE11 MD0	-	PE10 MD2	PE10 MD1	PE10 MD0	-	PE9 MD2	PE9 MD1	PE9 MD0	-	PE8 MD2	PE8 MD1	PE8 MD0
Initial value:	0	0	0	0	0	0	0	0	0	0	0	0	0	0	0	0
R/W:	R	R/W	R/W	R/W	R	R/W	R/W	R/W	R	R/W	R/W	R/W	R	R/W	R/W	R/W

Bit	Bit Name	Initial Value	R/W	Description
15	—	0	R	Reserved This bit is always read as 0. The write value should always be 0.
14	PE11MD2	0	R/W	PE11 Mode
13	PE11MD1	0	R/W	Select the function of the PE11/TIOC3D pin.
12	PE11MD0	0	R/W	000: PE11 I/O (port) 001: TIOC3D I/O (MTU2) Other than above: Setting prohibited
11	—	0	R	Reserved This bit is always read as 0. The write value should always be 0.
10	PE10MD2	0	R/W	PE10 Mode
9	PE10MD1	0	R/W	Select the function of the PE10/TIOC3C pin.
8	PE10MD0	0	R/W	000: PE10 I/O (port) 001: TIOC3C I/O (MTU2) Other than above: Setting prohibited

Bit	Bit Name	Initial Value	R/W	Description
7	—	0	R	Reserved This bit is always read as 0. The write value should always be 0.
6	PE9MD2	0	R/W	PE9 Mode
5	PE9MD1	0	R/W	Select the function of the PE9/TIOC3B pin.
4	PE9MD0	0	R/W	000: PE9 I/O (port) 001: TIOC3B I/O (MTU2) Other than above: Setting prohibited
3	—	0	R	Reserved This bit is always read as 0. The write value should always be 0.
2	PE8MD2	0	R/W	PE8 Mode
1	PE8MD1	0	R/W	Select the function of the PE8/TIOC3A pin.
0	PE8MD0	0	R/W	000: PE8 I/O (port) 001: TIOC3A I/O (MTU2) Other than above: Setting prohibited

- Port E Control Register L2 (PECRL2)

Bit:	15	14	13	12	11	10	9	8	7	6	5	4	3	2	1	0
	-	-	-	-	-	-	-	-	-	-	-	-	-	-	-	-
Initial value:	0	0	0	0	0	0	0	0	0	0	0	0	0	0	0	0
R/W:	R	R	R	R	R	R	R	R	R	R	R	R	R	R	R	R

Bit	Bit Name	Initial Value	R/W	Description
15 to 0	—	All 0	R	Reserved These bits are always read as 0. The write value should always be 0.

- Port E Control Register L1 (PECRL1)

Bit:	15	14	13	12	11	10	9	8	7	6	5	4	3	2	1	0
	-	PE3 MD2	PE3 MD1	PE3 MD0	-	PE2 MD2	PE2 MD1	PE2 MD0	-	PE1 MD2	PE1 MD1	PE1 MD0	-	-	PE0 MD1	PE0 MD0
Initial value:	0	0	0	0	0	0	0	0	0	0	0	0	0	0	0	0
R/W:	R	R/W	R/W	R/W	R	R/W	R/W	R/W	R	R/W	R/W	R/W	R	R	R/W	R/W

Bit	Bit Name	Initial Value	R/W	Description
15	—	0	R	Reserved This bit is always read as 0. The write value should always be 0.
14	PE3MD2	0	R/W	PE3 Mode
13	PE3MD1	0	R/W	Select the function of the PE3/TIOC0D/SCK0 pin.
12	PE3MD0	0	R/W	000: PE3 I/O (port) 001: TIOC0D I/O (MTU2) 110: SCK0 I/O (SCI) Other than above: Setting prohibited
11	—	0	R	Reserved This bit is always read as 0. The write value should always be 0.
10	PE2MD2	0	R/W	PE2 Mode
9	PE2MD1	0	R/W	Select the function of the PE2/TIOC0C/TXD0 pin.
8	PE2MD0	0	R/W	000: PE2 I/O (port) 001: TIOC0C I/O (MTU2) 110: TXD0 output (SCI) Other than above: Setting prohibited
7	—	0	R	Reserved This bit is always read as 0. The write value should always be 0.
6	PE1MD2	0	R/W	PE1 Mode
5	PE1MD1	0	R/W	Select the function of the PE1/TIOC0B/RXD0 pin.
4	PE1MD0	0	R/W	000: PE1 I/O (port) 001: TIOC0B I/O (MTU2) 110: RXD0 input (SCI) Other than above: Setting prohibited



Bit	Bit Name	Initial Value	R/W	Description
3, 2	—	All 0	R	Reserved These bits are always read as 0. The write value should always be 0.
1	PE0MD1	0	R/W	PE0 Mode
0	PE0MD0	0	R/W	Select the function of the PE0/TIOC0A pin. 00: PE0 I/O (port) 01: TIOC0A I/O (MTU2) Other than above: Setting prohibited

### 15.1.7 IRQOUT Function Control Register (IFCR)

IFCR is a 16-bit readable/writable register that is used to control the IRQOUT pin output when it is selected as the multiplexed pin function by port E control register L4 (PECRL4). When PECRL4 selects another function, the IFCR setting does not affect the pin function.

Bit:	15	14	13	12	11	10	9	8	7	6	5	4	3	2	1	0
Initial value:	0	0	0	0	0	0	0	0	0	0	0	0	0	0	0	0
R/W:	R	R	R	R	R	R	R	R	R	R	R	R	R	R	R/W	R/W

Bit	Bit Name	Initial Value	R/W	Description
15 to 2	—	All 0	R	Reserved These bits are always read as 0. The write value should always be 0.
1	IRQMD1	0	R/W	Port E $\overline{\text{IRQOUT}}$ Pin Function Select
0	IRQMD0	0	R/W	Select the $\overline{\text{IRQOUT}}$ pin function when bits 14 to 12 (PE15MD2 to PE15MD0) in PECRL4 are set to B'011. 00: Interrupt request accept signal output Other than above: Always high-level output

## 15.2 Usage Notes

1. In this LSI, the same function is available as a multiplexed function on multiple pins. This approach is intended to increase the number of selectable pin functions and to allow the easier design of boards. If two or more pins are specified for one function, however, there are two cautions shown below.

— When the pin function is input

Signals input to several pins are formed as one signal through OR or AND logic and the signal is transmitted into the LSI. Therefore, a signal that differs from the input signals may be transmitted to the LSI depending on the input signals in other pins that have the same functions. Table 15.6 shows the transmit forms of input functions allocated to several pins. When using one of the functions shown below in multiple pins, use it with care of signal polarity considering the transmit forms.

**Table 15.6 Transmit Forms of Input Functions Allocated to Multiple Pins**

OR Type	AND Type
SCK0 to SCK2, RXD0 to RXD2, $\overline{\text{POE0}}$ , $\overline{\text{POE1}}$ , $\overline{\text{POE3}}$ *, $\overline{\text{POE8}}$	IRQ0* to IRQ3

Note: \* This pin is supported only by the SH7125.

OR type: Signals input to several pins are formed as one signal through OR logic and the signal is transmitted into the LSI.

AND type: Signals input to several pins are formed as one signal through AND logic and the signal is transmitted into the LSI.

— When the pin function is output

Each selected pin can output the same function.

2. When the port input is switched from a low level to the IRQ edge for the pins that are multiplexed with input/output and IRQ, the corresponding edge is detected.
3. Do not set functions other than those specified in tables 15.3 and 15.4. Otherwise, correct operation cannot be guaranteed.

## Section 16 I/O Ports

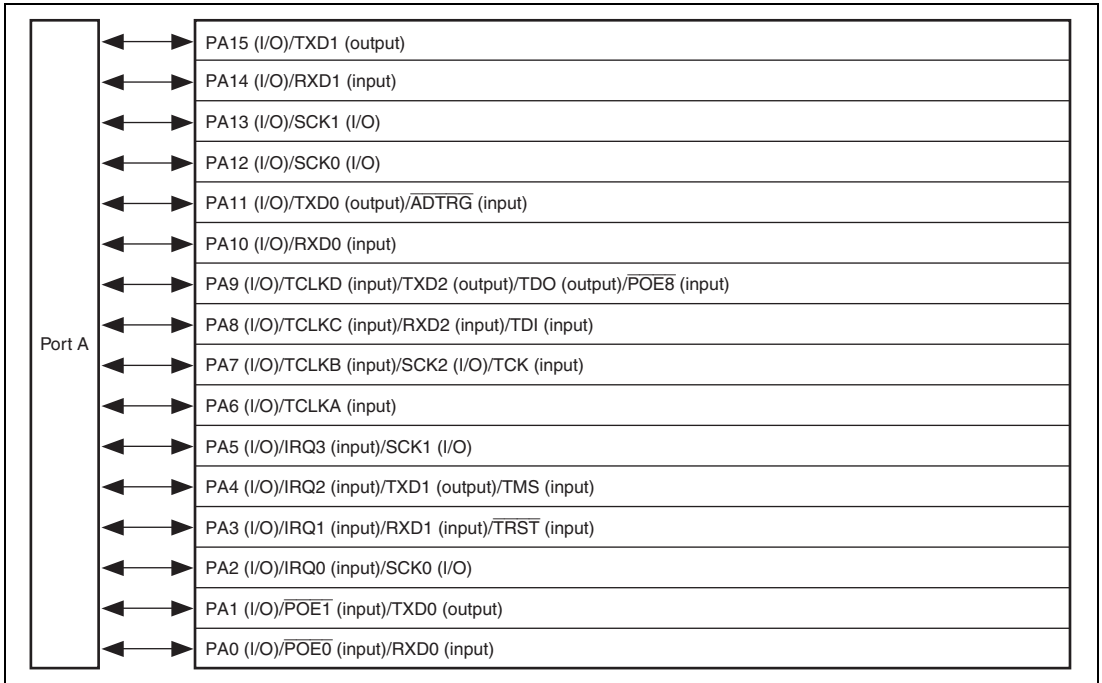
The SH7125 has four ports: A, B, E, and F. Port A is a 16-bit port, port B is a 5-bit port, and port E is a 16-bit port. Port F is an 8-bit input-only port.

The SH7124 has four ports: A, B, E, and F. Port A is an 8-bit port, port B is a 3-bit port, and port E is a 12-bit port. Port F is an 8-bit input-only port.

All the port pins are multiplexed as general input/output pins and special function pins. The functions of the multiplex pins are selected by means of the pin function controller (PFC). Each port is provided with a data register for storing the pin data.

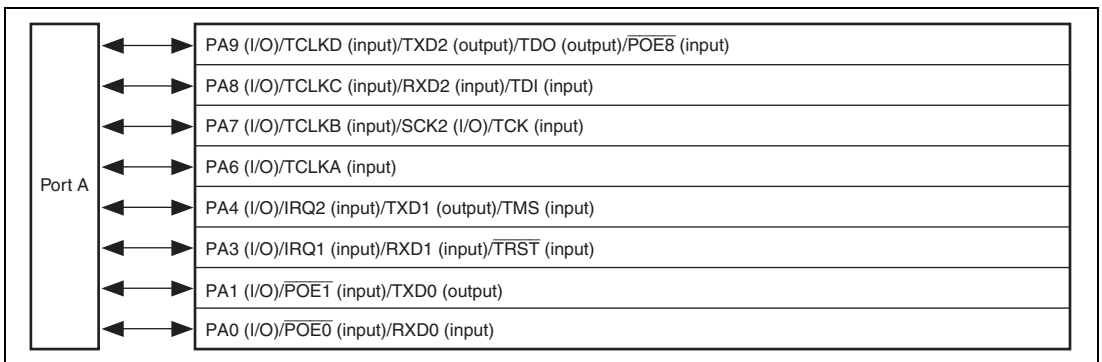
## 16.1 Port A

Port A in the SH7125 is an input/output port with the 16 pins shown in figure 16.1.



**Figure 16.1 Port A (SH7125)**

Port A in the SH7124 is an input/output port with the eight pins shown in figure 16.2.



**Figure 16.2 Port A (SH7124)**

### 16.1.1 Register Descriptions

Port A is a 16-bit input/output port in the SH7125 and an 8-bit input/output port in the SH7124. Port A has the following registers. For details on register addresses and register states during each processing, refer to section 20, List of Registers.

**Table 16.1 Register Configuration**

Register Name	Abbrevia- tion	R/W	Initial Value	Address	Access Size
Port A data register L	PADRL	R/W	H'0000	H'FFFFD102	8, 16
Port A port register L	PAPRL	R	—	H'FFFFD11E	8, 16

### 16.1.2 Port A Data Register L (PADRL)

PADRL is a 16-bit readable/writable register that stores port A data. Bits PA15DR to PA0DR correspond to pins PA15 to PA0 (multiplexed functions omitted here) in the SH7125. Bits PA9DR to PA6DR, PA4DR, PA3DR, PA1DR, and PA0DR correspond to pins PA9 to PA6, PA4, PA3, PA1, and PA0, respectively (multiplexed functions omitted here) in the SH7124.

When a pin function is general output, if a value is written to PADRL, that value is output directly from the pin, and if PADRL is read, the register value is returned directly regardless of the pin state.

When a pin function is general input, if PADRL is read, the pin state, not the register value, is returned directly. If a value is written to PADRL, although that value is written into PADRL, it does not affect the pin state. Table 16.2 summarizes port A data register read/write operations.

- PADRL (SH7125)

Bit:	15	14	13	12	11	10	9	8	7	6	5	4	3	2	1	0
	PA15 DR	PA14 DR	PA13 DR	PA12 DR	PA11 DR	PA10 DR	PA9 DR	PA8 DR	PA7 DR	PA6 DR	PA5 DR	PA4 DR	PA3 DR	PA2 DR	PA1 DR	PA0 DR
Initial value:	0	0	0	0	0	0	0	0	0	0	0	0	0	0	0	0
R/W:	R/W	R/W	R/W	R/W	R/W	R/W	R/W	R/W	R/W	R/W	R/W	R/W	R/W	R/W	R/W	R/W

Bit	Bit Name	Initial Value	R/W	Description
15	PA15DR	0	R/W	See table 16.2.
14	PA14DR	0	R/W	
13	PA13DR	0	R/W	
12	PA12DR	0	R/W	
11	PA11DR	0	R/W	
10	PA10DR	0	R/W	
9	PA9DR	0	R/W	
8	PA8DR	0	R/W	
7	PA7DR	0	R/W	
6	PA6DR	0	R/W	
5	PA5DR	0	R/W	
4	PA4DR	0	R/W	
3	PA3DR	0	R/W	
2	PA2DR	0	R/W	
1	PA1DR	0	R/W	
0	PA0DR	0	R/W	

- PADRL (SH7124)

Bit:	15	14	13	12	11	10	9	8	7	6	5	4	3	2	1	0
	-	-	-	-	-	-	PA9 DR	PA8 DR	PA7 DR	PA6 DR	-	PA4 DR	PA3 DR	-	PA1 DR	PA0 DR
Initial value:	0	0	0	0	0	0	0	0	0	0	0	0	0	0	0	0
R/W:	R	R	R	R	R	R	R/W	R/W	R/W	R/W	R	R/W	R/W	R	R/W	R/W

Bit	Bit Name	Initial Value	R/W	Description
15 to 10	—	All 0	R	Reserved These bits are always read as 0. The write value should always be 0.
9	PA9DR	0	R/W	See table 16.2.
8	PA8DR	0	R/W	
7	PA7DR	0	R/W	
6	PA6DR	0	R/W	
5	—	0	R	Reserved This bit is always read as 0. The write value should always be 0.
4	PA4DR	0	R/W	See table 16.2.
3	PA3DR	0	R/W	
2	—	0	R	Reserved This bit is always read as 0. The write value should always be 0.
1	PA1DR	0	R/W	See table 16.2.
0	PA0DR	0	R/W	

**Table 16.2 Port A Data Register L (PADRL) Read/Write Operations**

- PADRL Bits 15 to 0

<b>PAIORH, PAIORL</b>	<b>Pin Function</b>	<b>Read</b>	<b>Write</b>
0	General input	Pin state	Can write to PADRL, but it has no effect on pin state
	Other than general input	Pin state	Can write to PADRL, but it has no effect on pin state
1	General output	PADRL value	Value written is output from pin
	Other than general output	PADRL value	Can write to PADRL, but it has no effect on pin state



### 16.1.3 Port A Port Register L (PAPRL)

PAPRL is a 16-bit read-only register that always return the states of the pins regardless of the PFC setting. Bits PA15PR to PA0PR correspond to pins PA15 to PA0 (multiplexed functions omitted here) in the SH7125. Bits PA9PR to PA6PR, PA4PR, PA3PR, PA1PR, and PA0PR correspond to pins PA9 to PA6, PA4, PA3, PA1, and PA0, respectively (multiplexed functions omitted here) in the SH7124.

- PAPRL (SH7125)

Bit:	15	14	13	12	11	10	9	8	7	6	5	4	3	2	1	0
	PA15 PR	PA14 PR	PA13 PR	PA12 PR	PA11 PR	PA10 PR	PA9 PR	PA8 PR	PA7 PR	PA6 PR	PA5 PR	PA4 PR	PA3 PR	PA2 PR	PA1 PR	PA0 PR
Initial value:	*	*	*	*	*	*	*	*	*	*	*	*	*	*	*	*
R/W:	R	R	R	R	R	R	R	R	R	R	R	R	R	R	R	R

Bit	Bit Name	Initial Value	R/W	Description
15	PA15PR	Pin state	R	The pin state is returned regardless of the PFC setting. These bits cannot be modified.
14	PA14PR	Pin state	R	
13	PA13PR	Pin state	R	
12	PA12PR	Pin state	R	
11	PA11PR	Pin state	R	
10	PA10PR	Pin state	R	
9	PA9PR	Pin state	R	
8	PA8PR	Pin state	R	
7	PA7PR	Pin state	R	
6	PA6PR	Pin state	R	
5	PA5PR	Pin state	R	
4	PA4PR	Pin state	R	
3	PA3PR	Pin state	R	
2	PA2PR	Pin state	R	
1	PA1PR	Pin state	R	
0	PA0PR	Pin state	R	

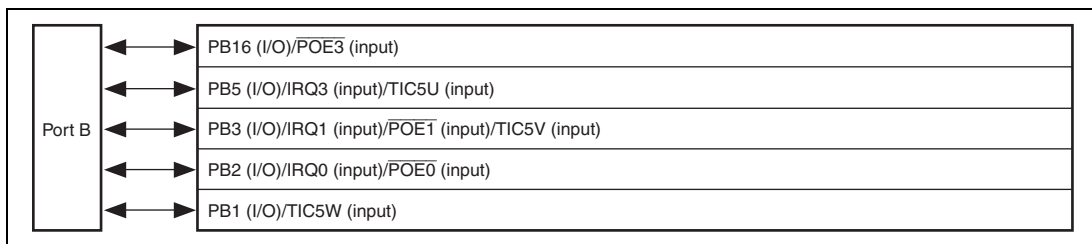
- PAPRL (SH7124)

Bit:	15	14	13	12	11	10	9	8	7	6	5	4	3	2	1	0
	-	-	-	-	-	-	PA9 PR	PA8 PR	PA7 PR	PA6 PR	-	PA4 PR	PA3 PR	-	PA1 PR	PA0 PR
Initial value:	0	0	0	0	0	0	*	*	*	*	0	*	*	0	*	*
R/W:	R	R	R	R	R	R	R	R	R	R	R	R	R	R	R	R

Bit	Bit Name	Initial Value	R/W	Description
15 to 10	—	All 0	R	Reserved These bits are always read as 0. The write value should always be 0.
9	PA9PR	Pin state	R	The pin state is returned regardless of the PFC setting.
8	PA8PR	Pin state	R	These bits cannot be modified.
7	PA7PR	Pin state	R	
6	PA6PR	Pin state	R	
5	—	0	R	Reserved This bit is always read as 0. The write value should always be 0.
4	PA4PR	Pin state	R	The pin state is returned regardless of the PFC setting.
3	PA3PR	Pin state	R	These bits cannot be modified.
2	—	0	R	Reserved This bit is always read as 0. The write value should always be 0.
1	PA1PR	Pin state	R	The pin state is returned regardless of the PFC setting.
0	PA0PR	Pin state	R	These bits cannot be modified.

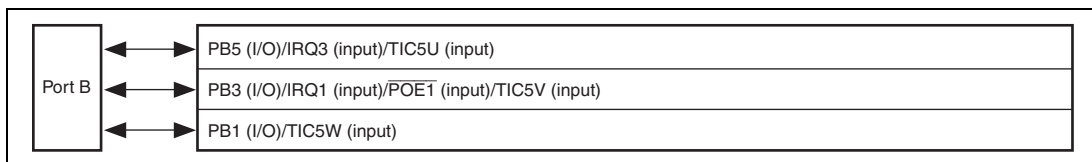
## 16.2 Port B

Port B in the SH7125 is an input/output port with the five pins shown in figure 16.3.



**Figure 16.3 Port B (SH7125)**

Port B in the SH7124 is an input/output port with the three pins shown in figure 16.4.



**Figure 16.4 Port B (SH7124)**

### 16.2.1 Register Descriptions

Port B is a 5-bit input/output port in the SH7125 and a 3-bit input/output port in the SH7124. Port B has the following register. For details on register addresses and register states during each processing, refer to section 20, List of Registers.

**Table 16.3 Register Configuration**

Register Name	Abbrevia- tion	R/W	Initial Value	Address	Access Size
Port B data register H	PBDRH	R/W	H'0000	H'FFFFD180	8, 16, 32
Port B data register L	PBDRL	R/W	H'0000	H'FFFFD182	8, 16
Port B port register H	PBPRH	R	—	H'FFFFD19C	8, 16, 32
Port B port register L	PBPRL	R	—	H'FFFFD19E	8, 16

## 16.2.2 Port B Data Registers H and L (PBDRH and PBDRL)

PBDRH and PBDRL are 16-bit readable/writable registers that store port B data. Bits PB16DR, PB5DR, and PB3DR to PB1DR correspond to pins PB16, PB5, and PB3 to PB1, respectively (multiplexed functions omitted here) in the SH7125. Bits PB5DR, PB3DR, and PB1DR correspond to pins PB5, PB3, and PB1, respectively (multiplexed functions omitted here) in the SH7124.

When a pin function is general output, if a value is written to PBDRH or PBDRL, that value is output directly from the pin, and if PBDRH or PBDRL is read, the register value is returned directly regardless of the pin state.

When a pin function is general input, if PBDRH or PBDRL is read, the pin state, not the register value, is returned directly. If a value is written to PBDRH or PBDRL, although that value is written into PBDRH or PBDRL, it does not affect the pin state. Table 16.4 summarizes port B data register read/write operations.

- PBDRH (SH7125)

Bit:	15	14	13	12	11	10	9	8	7	6	5	4	3	2	1	0	
	-	-	-	-	-	-	-	-	-	-	-	-	-	-	-	-	PB16DR
Initial value:	0	0	0	0	0	0	0	0	0	0	0	0	0	0	0	0	0
R/W:	R	R	R	R	R	R	R	R	R	R	R	R	R	R	R	R	R/W

Bit	Bit Name	Initial Value	R/W	Description
15 to 1	—	All 0	R	Reserved These bits are always read as 0. The write value should always be 0.
0	PB16DR	0	R/W	See table 16.4.

- **PBDRH (SH7124)**

Bit:	15	14	13	12	11	10	9	8	7	6	5	4	3	2	1	0
	-	-	-	-	-	-	-	-	-	-	-	-	-	-	-	-
Initial value:	0	0	0	0	0	0	0	0	0	0	0	0	0	0	0	0
R/W:	R	R	R	R	R	R	R	R	R	R	R	R	R	R	R	R

Bit	Bit Name	Initial Value	R/W	Description
15 to 0	—	All 0	R	Reserved These bits are always read as 0. The write value should always be 0.

- **PBDRL (SH7125)**

Bit:	15	14	13	12	11	10	9	8	7	6	5	4	3	2	1	0
	-	-	-	-	-	-	-	-	-	-	PB5DR	-	PB3DR	PB2DR	PB1DR	-
Initial value:	0	0	0	0	0	0	0	0	0	0	0	0	0	0	0	0
R/W:	R	R	R	R	R	R	R	R	R	R	R/W	R	R/W	R/W	R/W	R

Bit	Bit Name	Initial Value	R/W	Description
15 to 6	—	All 0	R	Reserved These bits are always read as 0. The write value should always be 0.
5	PB5DR	0	R/W	See table 16.4.
4	—	0	R	Reserved This bit is always read as 0. The write value should always be 0.
3	PB3DR	0	R/W	See table 16.4.
2	PB2DR	0	R/W	
1	PB1DR	0	R/W	
0	—	0	R	Reserved This bit is always read as 0. The write value should always be 0.

- PBDRL (SH7124)

Bit:	15	14	13	12	11	10	9	8	7	6	5	4	3	2	1	0
	-	-	-	-	-	-	-	-	-	-	PB5 DR	-	PB3 DR	-	PB1 DR	-
Initial value:	0	0	0	0	0	0	0	0	0	0	0	0	0	0	0	0
R/W:	R	R	R	R	R	R	R	R	R	R	R/W	R	R/W	R	R/W	R

Bit	Bit Name	Initial Value	R/W	Description
15 to 6	—	All 0	R	Reserved These bits are always read as 0. The write value should always be 0.
5	PB5DR	0	R/W	See table 16.4.
4	—	0	R	Reserved This bit is always read as 0. The write value should always be 0.
3	PB3DR	0	R/W	See table 16.4.
2	—	0	R	Reserved This bit is always read as 0. The write value should always be 0.
1	PB1DR	0	R/W	See table 16.4.
0	—	0	R	Reserved This bit is always read as 0. The write value should always be 0.

**Table 16.4 Port B Data Register (PBDR) Read/Write Operations**

- PBDRH Bit 0 and PBDRL Bits 5 and 3 to 1

PBIOR	Pin Function	Read	Write
0	General input	Pin state	Can write to PBDRH and PBDRL, but it has no effect on pin state
	Other than general input	Pin state	Can write to PBDRH and PBDRL, but it has no effect on pin state
1	General output	PBDRH or PBDRL value	Value written is output from pin
	Other than general output	PBDRH or PBDRL value	Can write to PBDRH and PBDRL, but it has no effect on pin state

### 16.2.3 Port B Port Registers H and L (PBPRH and PBPRL)

PBPRH and PBPRL are 16-bit read-only registers that always return the states of the pins regardless of the PFC setting. Bits PB16PR, PB5PR, and PB3PR to PB1PR correspond to pins PB16, PB5, and PB3 to PB1, respectively (multiplexed functions omitted here) in the SH7125. Bits PB5PR, PB3PR, and PB1PR correspond to pins PB5, PB3, and PB1, respectively (multiplexed functions omitted here) in the SH7124.

- PBPRH (SH7125)

Bit:	15	14	13	12	11	10	9	8	7	6	5	4	3	2	1	0
	-	-	-	-	-	-	-	-	-	-	-	-	-	-	-	PB16 PR
Initial value:	0	0	0	0	0	0	0	0	0	0	0	0	0	0	0	*
R/W:	R	R	R	R	R	R	R	R	R	R	R	R	R	R	R	R

Bit	Bit Name	Initial Value	R/W	Description
15 to 1	—	All 0	R	Reserved  These bits are always read as 0. The write value should always be 0.
0	PB16PR	Pin state	R	The pin state is returned regardless of the PFC setting. This bit cannot be modified.

- PBPRH (SH7124)

Bit:	15	14	13	12	11	10	9	8	7	6	5	4	3	2	1	0
	-	-	-	-	-	-	-	-	-	-	-	-	-	-	-	-
Initial value:	0	0	0	0	0	0	0	0	0	0	0	0	0	0	0	0
R/W:	R	R	R	R	R	R	R	R	R	R	R	R	R	R	R	R

Bit	Bit Name	Initial Value	R/W	Description
15 to 0	—	All 0	R	Reserved  These bits are always read as 0. The write value should always be 0.

- PBPRL (SH7125)

Bit:	15	14	13	12	11	10	9	8	7	6	5	4	3	2	1	0
	-	-	-	-	-	-	-	-	-	-	PB5 PR	-	PB3 PR	PB2 PR	PB1 PR	-
Initial value:	0	0	0	0	0	0	0	0	0	0	*	0	*	*	*	0
R/W:	R	R	R	R	R	R	R	R	R	R	R	R	R	R	R	R

Bit	Bit Name	Initial Value	R/W	Description
15 to 6	—	All 0	R	Reserved These bits are always read as 0. The write value should always be 0.
5	PB5PR	Pin state	R	The pin state is returned regardless of the PFC setting. This bit cannot be modified.
4	—	0	R	Reserved This bit is always read as 0. The write value should always be 0.
3	PB3PR	Pin state	R	The pin state is returned regardless of the PFC setting.
2	PB2PR	Pin state	R	These bits cannot be modified.
1	PB1PR	Pin state	R	
0	—	0	R	Reserved This bit is always read as 0. The write value should always be 0.



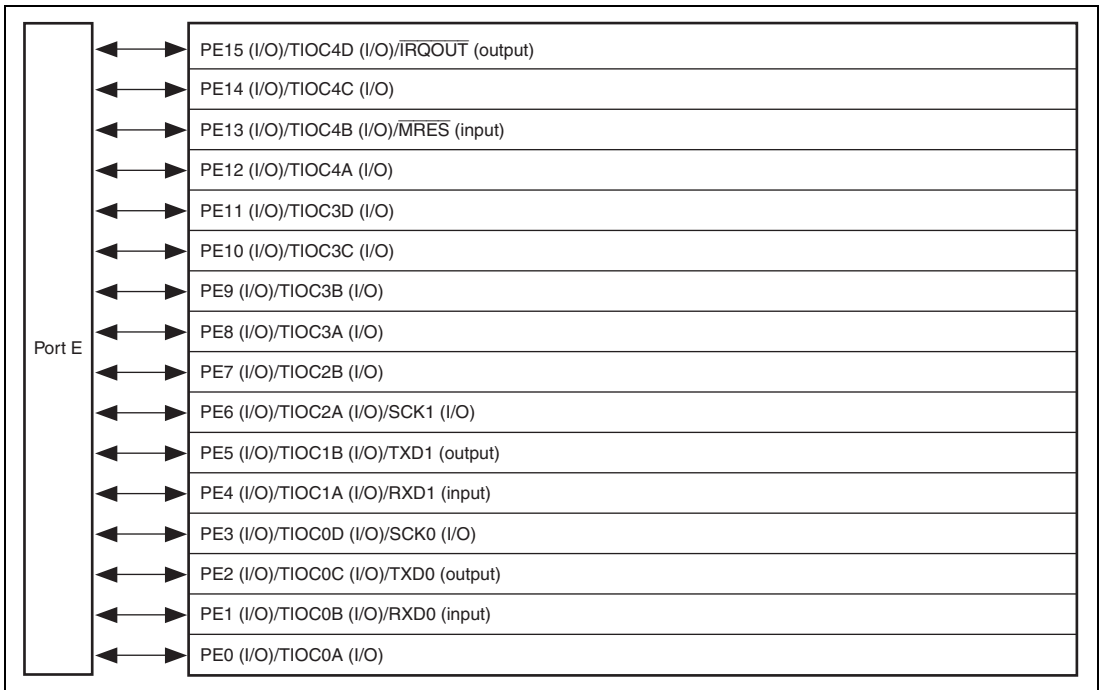
- PBPRL (SH7124)

Bit:	15	14	13	12	11	10	9	8	7	6	5	4	3	2	1	0
	-	-	-	-	-	-	-	-	-	-	PB5 PR	-	PB3 PR	-	PB1 PR	-
Initial value:	0	0	0	0	0	0	0	0	0	0	*	0	*	0	*	0
R/W:	R	R	R	R	R	R	R	R	R	R	R	R	R	R	R	R

Bit	Bit Name	Initial Value	R/W	Description
15 to 6	—	All 0	R	Reserved These bits are always read as 0. The write value should always be 0.
5	PB5PR	Pin state	R	The pin state is returned regardless of the PFC setting. This bit cannot be modified.
4	—	0	R	Reserved This bit is always read as 0. The write value should always be 0.
3	PB3PR	Pin state	R	The pin state is returned regardless of the PFC setting. This bit cannot be modified.
2	—	0	R	Reserved This bit is always read as 0. The write value should always be 0.
1	PB1PR	Pin state	R	The pin state is returned regardless of the PFC setting. This bit cannot be modified.
0	—	0	R	Reserved This bit is always read as 0. The write value should always be 0.

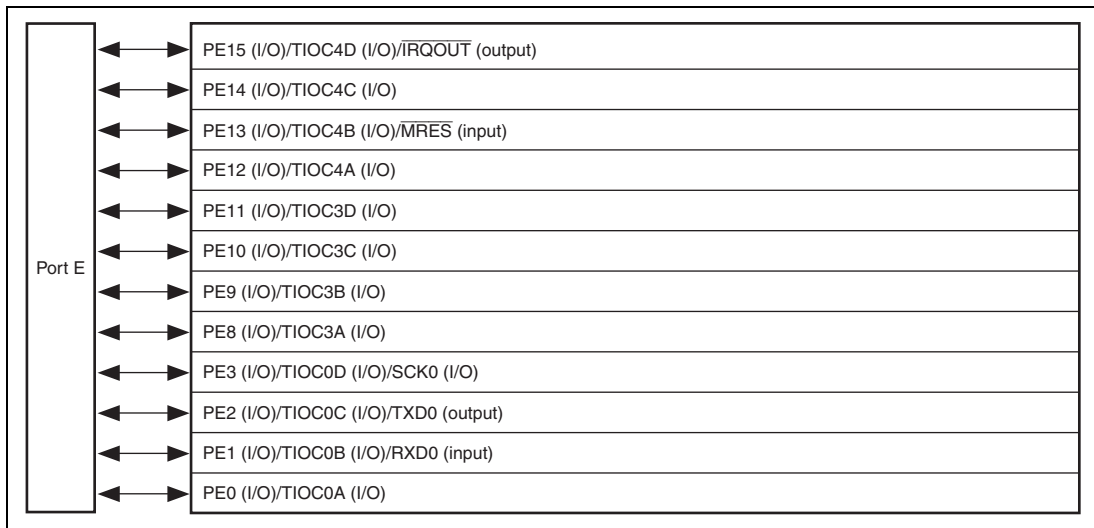
## 16.3 Port E

Port E in the SH7125 is an input/output port with the 16 pins shown in figure 16.5.



**Figure 16.5 Port E (SH7125)**

Port E in the SH7124 is an input/output port with the 12 pins shown in figure 16.6.



**Figure 16.6 Port E (SH7124)**

### 16.3.1 Register Descriptions

Port E is a 16-bit input/output port in the SH7125 and a 12-bit input/output port in the SH7124. Port E has the following registers. For details on register addresses and register states during each processing, refer to section 20, List of Registers.

**Table 16.5 Register Configuration**

Register Name	Abbreviation	R/W	Initial Value	Address	Access Size
Port E data register L	PEDRL	R/W	H'0000	H'FFFFD302	8, 16
Port E port register L	PEPRL	R	—	H'FFFFD31E	8, 16

### 16.3.2 Port E Data Register L (PEDRL)

PEDRL is a 16-bit readable/writable register that stores port E data. Bits PE15DR to PE0DR correspond to pins PE15 to PE0 (multiplexed functions omitted here) in the SH7125. Bits PE15DR to PE8DR and PE3DR to PE0DR correspond to pins PE15 to PE8 and PE3 to PE0, respectively (multiplexed functions omitted here) in the SH7124.

When a pin function is general output, if a value is written to PEDRL, that value is output directly from the pin, and if PEDRL is read, the register value is returned directly regardless of the pin state.

When a pin function is general input, if PEDRL is read, the pin state, not the register value, is returned directly. If a value is written to PEDRL, although that value is written into PEDRL, it does not affect the pin state. Table 16.6 summarizes port E data register read/write operations.

- PEDRL (SH7125)

Bit:	15	14	13	12	11	10	9	8	7	6	5	4	3	2	1	0
	PE15 DR	PE14 DR	PE13 DR	PE12 DR	PE11 DR	PE10 DR	PE9 DR	PE8 DR	PE7 DR	PE6 DR	PE5 DR	PE4 DR	PE3 DR	PE2 DR	PE1 DR	PE0 DR
Initial value:	0	0	0	0	0	0	0	0	0	0	0	0	0	0	0	0
R/W:	R/W	R/W	R/W	R/W	R/W	R/W	R/W	R/W	R/W	R/W	R/W	R/W	R/W	R/W	R/W	R/W

Bit	Bit Name	Initial Value	R/W	Description
15	PE15DR	0	R/W	See table 16.6.
14	PE14DR	0	R/W	
13	PE13DR	0	R/W	
12	PE12DR	0	R/W	
11	PE11DR	0	R/W	
10	PE10DR	0	R/W	
9	PE9DR	0	R/W	
8	PE8DR	0	R/W	
7	PE7DR	0	R/W	
6	PE6DR	0	R/W	
5	PE5DR	0	R/W	
4	PE4DR	0	R/W	
3	PE3DR	0	R/W	
2	PE2DR	0	R/W	
1	PE1DR	0	R/W	
0	PE0DR	0	R/W	

- PEDRL (SH7124)

Bit:	15	14	13	12	11	10	9	8	7	6	5	4	3	2	1	0
	PE15 DR	PE14 DR	PE13 DR	PE12 DR	PE11 DR	PE10 DR	PE9 DR	PE8 DR	-	-	-	-	PE3 DR	PE2 DR	PE1 DR	PE0 DR
Initial value:	0	0	0	0	0	0	0	0	0	0	0	0	0	0	0	0
R/W:	R/W	R/W	R/W	R/W	R/W	R/W	R/W	R/W	R	R	R	R	R/W	R/W	R/W	R/W

Bit	Bit Name	Initial Value	R/W	Description
15	PE15DR	0	R/W	See table 16.6.
14	PE14DR	0	R/W	
13	PE13DR	0	R/W	
12	PE12DR	0	R/W	
11	PE11DR	0	R/W	
10	PE10DR	0	R/W	
9	PE9DR	0	R/W	
8	PE8DR	0	R/W	
7 to 4	—	All 0	R	Reserved These bits are always read as 0. The write value should always be 0.
3	PE3DR	0	R/W	See table 16.6.
2	PE2DR	0	R/W	
1	PE1DR	0	R/W	
0	PE0DR	0	R/W	

**Table 16.6 Port E Data Register L (PEDRL) Read/Write Operations**

- PEDRL Bits 15 to 0

PEIOR	Pin Function	Read	Write
0	General input	Pin state	Can write to PEDRL, but it has no effect on pin state
	Other than general input	Pin state	Can write to PEDRL, but it has no effect on pin state
1	General output	PEDRL value	Value written is output from pin
	Other than general output	PEDRL value	Can write to PEDRL, but it has no effect on pin state

### 16.3.3 Port E Port Register L (PEPRL)

PEPRL is a 16-bit read-only register that always returns the states of the pins regardless of the PFC setting. Bits PE15PR to PE0PR correspond to pins PE15 to PE0 (multiplexed functions omitted here) in the SH7125. Bits PE15PR to PE8PR and PE3PR to PE0PR correspond to pins PE15 to PE8 and PE3 to PE0, respectively (multiplexed functions omitted here) in the SH7124.

- PEPRL (SH7125)

Bit:	15	14	13	12	11	10	9	8	7	6	5	4	3	2	1	0
	PE15 PR	PE14 PR	PE13 PR	PE12 PR	PE11 PR	PE10 PR	PE9 PR	PE8 PR	PE7 PR	PE6 PR	PE5 PR	PE4 PR	PE3 PR	PE2 PR	PE1 PR	PE0 PR
Initial value:	*	*	*	*	*	*	*	*	*	*	*	*	*	*	*	*
R/W:	R	R	R	R	R	R	R	R	R	R	R	R	R	R	R	R

Bit	Bit Name	Initial Value	R/W	Description
15	PE15PR	Pin state	R	The pin state is returned regardless of the PFC setting. These bits cannot be modified.
14	PE14PR	Pin state	R	
13	PE13PR	Pin state	R	
12	PE12PR	Pin state	R	
11	PE11PR	Pin state	R	
10	PE10PR	Pin state	R	
9	PE9PR	Pin state	R	
8	PE8PR	Pin state	R	
7	PE7PR	Pin state	R	
6	PE6PR	Pin state	R	
5	PE5PR	Pin state	R	
4	PE4PR	Pin state	R	
3	PE3PR	Pin state	R	
2	PE2PR	Pin state	R	
1	PE1PR	Pin state	R	
0	PE0PR	Pin state	R	

- PEPRL (SH7124)

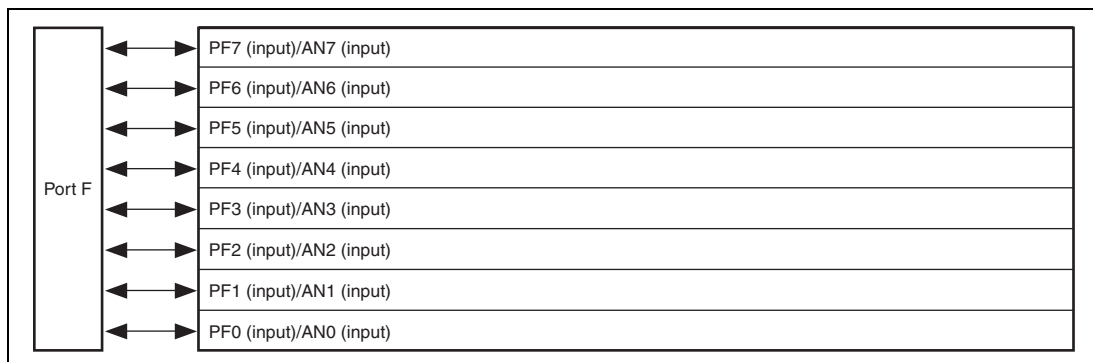
Bit:	15	14	13	12	11	10	9	8	7	6	5	4	3	2	1	0
	PE15 PR	PE14 PR	PE13 PR	PE12 PR	PE11 PR	PE10 PR	PE9 PR	PE8 PR	-	-	-	-	PE3 PR	PE2 PR	PE1 PR	PE0 PR
Initial value:	*	*	*	*	*	*	*	*	0	0	0	0	*	*	*	*
R/W:	R	R	R	R	R	R	R	R	R	R	R	R	R	R	R	R

Bit	Bit Name	Initial Value	R/W	Description
15	PE15PR	Pin state	R	The pin state is returned regardless of the PFC setting. These bits cannot be modified.
14	PE14PR	Pin state	R	
13	PE13PR	Pin state	R	
12	PE12PR	Pin state	R	
11	PE11PR	Pin state	R	
10	PE10PR	Pin state	R	
9	PE9PR	Pin state	R	
8	PE8PR	Pin state	R	
7 to 4	—	All 0	R	Reserved  These bits are always read as 0. The write value should always be 0.
3	PE3PR	Pin state	R	The pin state is returned regardless of the PFC setting. These bits cannot be modified.
2	PE2PR	Pin state	R	
1	PE1PR	Pin state	R	
0	PE0PR	Pin state	R	



## 16.4 Port F

Port F in the SH7125 and SH7124 is an input-only port with the eight pins shown in figure 16.7.



**Figure 16.7 Port F (SH7125, SH7124)**

### 16.4.1 Register Descriptions

Port F is an 8-bit input-only port in the SH7125 and SH7124. Port F has the following register. For details on register addresses and register states during each processing, refer to section 20, List of Registers.

**Table 16.7 Register Configuration**

Register Name	Abbrevia- tion	R/W	Initial Value	Address	Access Size
Port F data register L	PFDRL	R	—	H'FFFFD382	8, 16

## 16.4.2 Port F Data Register L (PFDRL)

The port F data register L (PFDRL) is a 16-bit read-only register that stores port F data. Bits PF7DR to PF0DR correspond to pins PF7 to PF0 (multiplexed functions omitted here) in the SH7125 and SH7124.

Any value written into these bits is ignored, and there is no effect on the state of the pins. When any of the bits are read, the pin state rather than the bit value is read directly. However, when an A/D converter analog input is being sampled, values of 1 are read. Table 16.8 summarizes port F data register L read/write operations.

- PFDRL (SH7125, SH7124)

Bit:	15	14	13	12	11	10	9	8	7	6	5	4	3	2	1	0
	-	-	-	-	-	-	-	-	PF7 DR	PF6 DR	PF5 DR	PF4 DR	PF3 DR	PF2 DR	PF1 DR	PF0 DR
Initial value:	0	0	0	0	0	0	0	0	*	*	*	*	*	*	*	*
R/W:	R	R	R	R	R	R	R	R	R	R	R	R	R	R	R	R

Bit	Bit Name	Initial Value	R/W	Description
15 to 8	—	All 0	R	Reserved These bits are always read as 0. The write value should always be 0.
7	PF7DR	Pin state	R	See table 16.8.
6	PF6DR	Pin state	R	
5	PF5DR	Pin state	R	
4	PF4DR	Pin state	R	
3	PF3DR	Pin state	R	
2	PF2DR	Pin state	R	
1	PF1DR	Pin state	R	
0	PF0DR	Pin state	R	

**Table 16.8 Port F Data Register L (PFDRL) Read/Write Operations**

- PFDRL Bits 7 to 0

Pin Function	Read	Write
General input	Pin state	Ignored (no effect on pin state)
ANn input	1	Ignored (no effect on pin state)

## Section 17 Flash Memory

This LSI has 128-Kbyte, 64-Kbyte, or 32-Kbyte on-chip flash memory. The flash memory has the following features.

### 17.1 Features

- Capacitance

SH71253, SH71243: 128 Kbytes

SH71252, SH71242: 64 Kbytes

SH71241: 32 Kbytes

- Two on-board programming modes and one off-board programming mode

— On-board programming modes

**Boot Mode:** This mode is a program mode that uses an on-chip SCI interface. The user MAT can be programmed. This mode can automatically adjust the bit rate between the host and this LSI.

**User Program Mode:** The user MAT can be programmed by using the optional interface. This mode cannot be used in 32-Kbyte on-chip flash memory version.

— Off-board programming mode

This mode uses the dedicated socket adapter and PROM programmer. The user MAT can be programmed.

- Programming/erasing interface by the download of on-chip program

This LSI has a dedicated programming/erasing program. After downloading this program to the on-chip RAM, programming/erasing can be performed by setting the argument parameter. The user branch is also supported.

— User branch

The program processing is performed in 128-byte units. It consists the program pulse application, verify read, and several other steps. Erasing is performed in one divided-block units and consists of several steps. The user processing routine can be executed between the steps, this setting for which is called the user branch addition.

- Protection modes

There are two protection modes. Software protection by the register setting and hardware protection by the FWE pin. The protection state for flash memory programming/erasing can be set.

When abnormalities, such as runaway of programming/erasing are detected, these modes enter the error protection state and the programming/erasing processing is suspended.

- Programming/erasing time

The flash memory programming time is  $t_p$  ms (Typ.) in 128-byte simultaneous programming and  $t_p/128$  ms per byte. The erasing time is  $t_e$  s (Typ.) per block.

- Number of programming

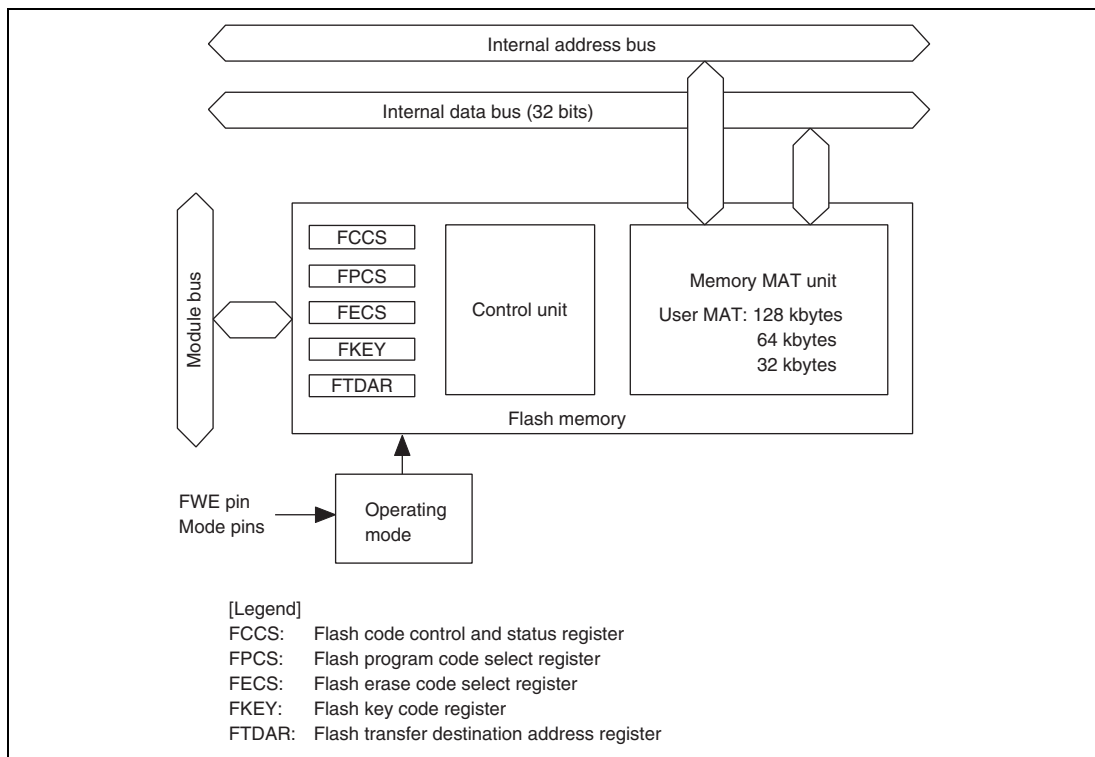
The number of flash memory programming can be up to  $N_{wec}$  times.

- Operating frequency at programming/erasing

The operating frequency at programming/erasing is a maximum of 40 MHz (Pφ).

## 17.2 Overview

### 17.2.1 Block Diagram

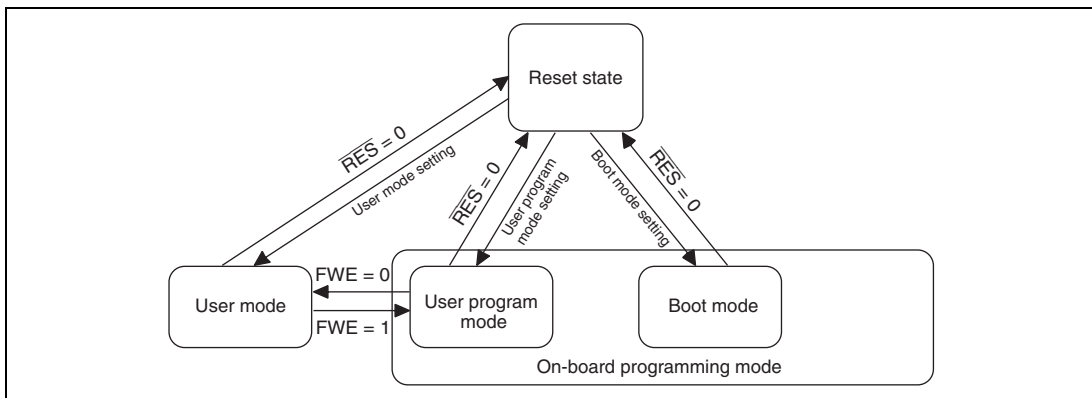


**Figure 17.1 Block Diagram of Flash Memory**

## 17.2.2 Operating Mode

When each mode pin and the FWE pin are set in the reset state and the reset signal is released, the microcomputer enters each operating mode as shown in figure 17.2. For the setting of each mode pin and the FWE pin, see tables 17.1 to 17.4.

- Flash memory can be read in user mode, but cannot be programmed or erased.
- Flash memory can be read, programmed, or erased on the board only in user program mode and boot mode.



**Figure 17.2 Mode Transition of Flash Memory**

**Table 17.1 Relationship between FWE and MD Pins and Operating Modes**

Pin	Reset State	User Mode	User Program Mode	Boot Mode
$\overline{RES}$	0	1	1	1
FWE	0/1	0	1	1
MD1	0/1	1	1	0

### 17.2.3 Mode Comparison

The comparison table of programming and erasing related items about boot mode and user program mode is shown in table 17.2.

**Table 17.2 Comparison of Programming Modes**

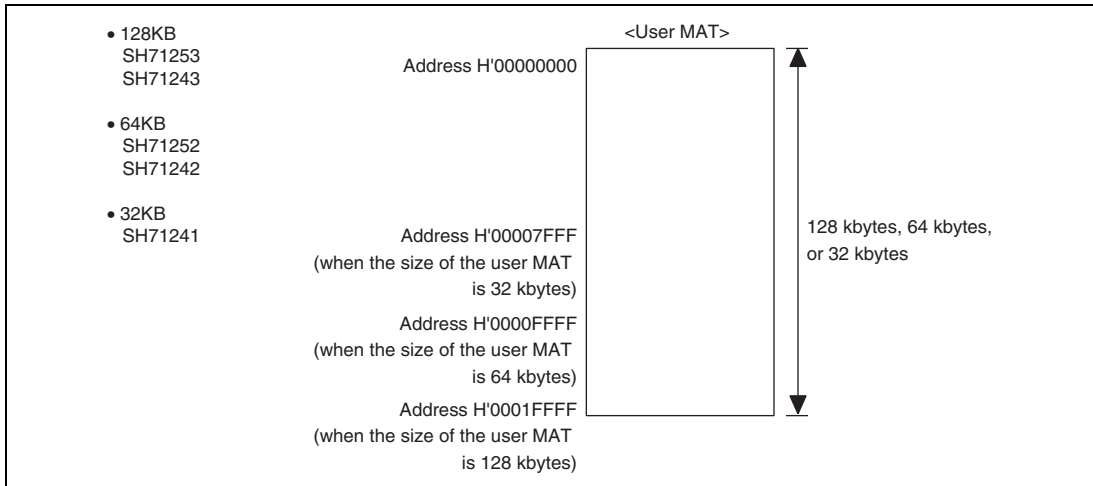
Programming/erasing environment	On-Board Programming		Off-Board Programming
	Boot Mode	User Program Mode* <sup>2</sup>	
Programming/erasing enable MAT	User MAT	User MAT	User MAT
Programming/erasing control	Command method	Programming/erasing interface	—
All erasure	Possible (Automatic)	Possible	Possible (Automatic)
Block division erasure	Possible* <sup>1</sup>	Possible	Impossible
Program data transfer	From host via SCI	From optional device via RAM	Via programmer
User branch function	Not possible	Possible	Impossible
Reset initiation MAT	Embedded program storage MAT	User MAT	Embedded program storage MAT
Transition to user mode	Mode setting change and reset	FWE setting change	—

Notes: 1. All-erasure is performed. After that, the specified block can be erased.  
2. Cannot be used in 32-kbyte on-chip flash memory version.

- The user MAT is all erased in boot mode. Then, the user MAT can be programmed by means of the command method. However, the contents of the MAT cannot be read until this state.

### 17.2.4 Flash Memory Configuration

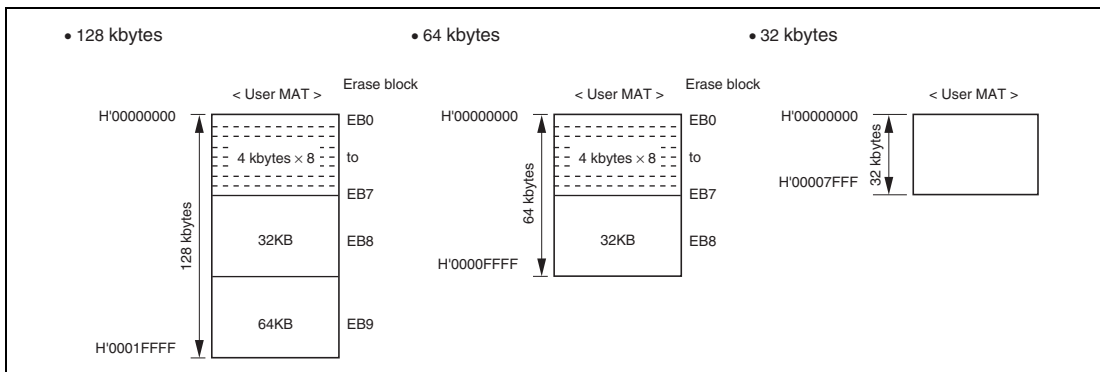
This LSI's flash memory is configured by the 128-Kbyte, 64-Kbyte, or 32-Kbyte user MAT.



**Figure 17.3 Flash Memory Configuration**

### 17.2.5 Block Division

The user MAT is divided into 64 Kbytes (128-kbyte version: one block), 32 Kbytes (one block), and 4 Kbytes (eight blocks) as shown in figure 17.4. The user MAT can be erased in this divided-block units and the erase-block number of EB0 to EB9 is specified when erasing. The user MAT is divided into 16 Kbytes (two blocks) for 32-Kbyte ROM version.



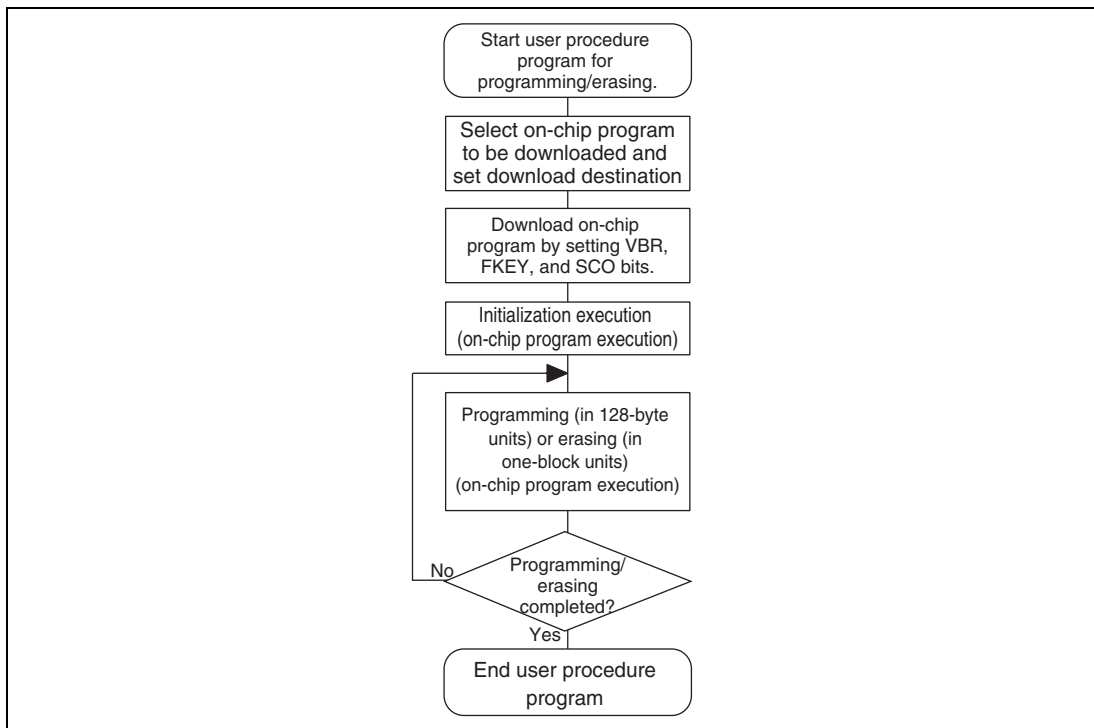
**Figure 17.4 Block Division of User MAT**



## 17.2.6 Programming/Erasing Interface

Programming/erasing is executed by downloading the on-chip program to the on-chip RAM and specifying the program address/data and erase block by using the interface registers/parameters.

The procedure program is made by the user in user program mode. The overview of the procedure is as follows. For details, see section 17.5.2, User Program Mode (Only in On-Chip 128-Kbyte and 64-Kbyte ROM Version).



**Figure 17.5 Overview of User Procedure Program**

### (1) Selection of On-Chip Program to be Downloaded and Setting of Download Destination

This LSI has programming/erasing programs and they can be downloaded to the on-chip RAM. The on-chip program to be downloaded is selected by setting the corresponding bits in the programming/erasing interface registers. The download destination can be specified by FTDAR.

## (2) Download of On-Chip Program

The on-chip program is automatically downloaded by clearing VBR of the CPU to H'84000000 and then setting the SCO bit in the flash code control and status register (FCCS) and the flash key code register (FKEY), which are programming/erasing interface registers. The user MAT is replaced to the embedded program storage area when downloading. Since the flash memory cannot be read when programming/erasing, the procedure program, which is working from download to completion of programming/erasing, must be executed in a space other than the flash memory to be programmed/erased (for example, on-chip RAM).

Since the result of download is returned to the programming/erasing interface parameters, whether the normal download is executed or not can be confirmed.

Note that VBR can be changed after download is completed.

## (3) Initialization of Programming/Erasing

The operating frequency and user branch are set before execution of programming/erasing. The user branch destination must be in an area other than the user MAT area, which is in the middle of programming and the area where the on-chip program is downloaded. These settings are performed by using the programming/erasing interface parameters.

## (4) Programming/Erasing Execution

To program or erase, the FWE pin must be brought high and user program mode must be entered.

The program data/programming destination address is specified in 128-byte units when programming.

The block to be erased is specified in erase-block units when erasing.

These specifications are set by using the programming/erasing interface parameters and the on-chip program is initiated. The on-chip program is executed by using the JSR or BSR instruction to perform the subroutine call of the specified address in the on-chip RAM. The execution result is returned to the programming/erasing interface parameters.

The area to be programmed must be erased in advance when programming flash memory.

There are limitations and notes on the interrupt processing during programming/erasing. For details, see section 17.7.1, Interrupts during Programming/Erasing.

## (5) When Programming/Erasing is Executed Consecutively

When the processing is not ended by the 128-byte programming or one-block erasure, the program address/data and erase-block number must be updated and consecutive programming/erasing is required.

Since the downloaded on-chip program is left in the on-chip RAM after the processing, download and initialization are not required when the same processing is executed consecutively.

## 17.3 Input/Output Pins

Flash memory is controlled by the pins as shown in table 17.3.

**Table 17.3 Pin Configuration**

Pin Name	Symbol	I/O	Function
Power-on reset	$\overline{\text{RES}}$	Input	Reset
Flash programming enable	FWE	Input	Hardware protection when programming flash memory
Mode 1	MD1	Input	Sets operating mode of this LSI
Transmit data	TXD1 (PA4)	Output	Serial transmit data output (used in boot mode)
Receive data	RXD1 (PA3)	Input	Serial receive data input (used in boot mode)

## 17.4 Register Descriptions

### 17.4.1 Registers

The registers/parameters, which control flash memory when the on-chip flash memory is valid are shown in table 17.4.

There are several operating modes for accessing flash memory, for example, read mode/program mode. The correspondence of operating modes and registers/parameters for use is shown in table 17.5.

**Table 17.4 (1) Register Configuration**

Register Name	Abbreviation* <sup>3</sup>	R/W	Initial Value	Address	Access Size
Flash code control and status register	FCCS	R, W* <sup>1</sup>	H'00* <sup>2</sup> H'80* <sup>2</sup>	H'FFFFCC00	8
Flash program code select register	FPCS	R/W	H'00	H'FFFFCC01	8
Flash erase code select register	FECS	R/W	H'00	H'FFFFCC02	8
Flash key code register	FKEY	R/W	H'00	H'FFFFCC04	8
Flash transfer destination address register	FTDAR	R/W	H'00	H'FFFFCC06	8

- Notes: 1. The bits except the SCO bit are read-only bits. The SCO bit is a programming-only bit. (The value, which can be read is always 0.)
2. The initial value of the FWE bit is 0 when the FWE pin goes low.  
The initial value of the FWE bit is 1 when the FWE pin goes high.
3. All registers can be accessed only in bytes.

**Table 17.4 (2) Parameter Configuration**

Name	Abbreviation	R/W	Initial Value	Address	Access Size
Download pass/fail result	DPFR	R/W	Undefined	On-chip RAM*	8, 16, 32
Flash pass/fail result	FPFR	R/W	Undefined	R0 of CPU	8, 16, 32
Flash multipurpose address area	FMPAR	R/W	Undefined	R5 of CPU	8, 16, 32
Flash multipurpose data destination area	FMPDR	R/W	Undefined	R4 of CPU	8, 16, 32
Flash erase block select	FEBS	R/W	Undefined	R4 of CPU	8, 16, 32
Flash program and erase frequency control	FPEFEQ	R/W	Undefined	R4 of CPU	8, 16, 32
Flash user branch address set parameter	FUBRA	R/W	Undefined	R5 of CPU	8, 16, 32

Note: \* One byte of the start address in the on-chip RAM area specified by FTDAR is valid.

**Table 17.5 Register/Parameter and Target Mode**

		Download	Initiali- zation	Program- ming	Eraseure	Read
Programming/ erasing interface registers	FCCS	√	—	—	—	—
	FPCS	√	—	—	—	—
	PECS	√	—	—	—	—
	FKEY	√	—	√	√	—
	FTDAR	√	—	—	—	—
Programming/ erasing interface parameters	DPFR	√	—	—	—	—
	FPFR	—	√	√	√	—
	FPEFEQ	—	√	—	—	—
	FUBRA	—	√	—	—	—
	FMPAR	—	—	√	—	—
	FMPDR	—	—	√	—	—
	FEBS	—	—	—	√	—

## 17.4.2 Programming/Erasing Interface Registers

The programming/erasing interface registers are as described below. They are all 8-bit registers that can be accessed in bytes.

### (1) Flash Code Control and Status Register (FCCS)

FCCS is configured by bits which request the monitor of the FWE pin state and error occurrence during programming or erasing flash memory and the download of the on-chip program.

Bit:	7	6	5	4	3	2	1	0
	FWE	-	-	FLER	-	-	-	SCO
Initial value:	1/0	0	0	0	0	0	0	0
R/W:	R	R	R	R	R	R	R	(R)/W

Bit	Bit Name	Initial Value	R/W	Description
7	FWE	1/0	R	Flash Programming Enable Monitors the level which is input to the FWE pin that performs hardware protection of the flash memory programming or erasing. The initial value is 0 or 1 according to the FWE pin state. 0: When the FWE pin goes low (in hardware protection state) 1: When the FWE pin goes high
6, 5	—	All 0	R	Reserved These bits are always read as 0. The write value should always be 0.

Bit	Bit Name	Initial Value	R/W	Description
4	FLER	0	R	<p>Flash Memory Error</p> <p>Indicates an error occurs during programming and erasing flash memory.</p> <p>When FLER is set to 1, flash memory enters the error protection state.</p> <p>When FLER is set to 1, high voltage is applied to the internal flash memory. To reduce the damage to flash memory, the reset signal must be released after the reset period of 100 <math>\mu</math>s, which is longer than normal.</p> <p>0: Flash memory operates normally Programming/erasing protection for flash memory (error protection) is invalid.</p> <p>[Clearing condition] At a power-on reset</p> <p>1: Indicates an error occurs during programming/erasing flash memory. Programming/erasing protection for flash memory (error protection) is valid.</p> <p>[Setting condition] See section 17.6.3, Error Protection.</p>
3 to 1	—	All 0	R	<p>Reserved</p> <p>These bits are always read as 0. The write value should always be 0.</p>

Bit	Bit Name	Initial Value	R/W	Description
0	SCO	0	(R)/W	<p>Source Program Copy Operation</p> <p>Requests the on-chip programming/erasing program to be downloaded to the on-chip RAM.</p> <p>When this bit is set to 1, the on-chip program which is selected by FPCS/FECS is automatically downloaded in the on-chip RAM area specified by FTDAR.</p> <p>In order to set this bit to 1, H'A5 must be written to FKEY and this operation must be in the on-chip RAM.</p> <p>Four NOP instructions must be executed immediately after setting this bit to 1.</p> <p>For interrupts during download, see section 17.7.1, Interrupts during Programming/Erasing. For the download time, see section 17.7.2, Other Notes.</p> <p>Since this bit is cleared to 0 when download is completed, this bit cannot be read as 1.</p> <p>Download by setting the SCO bit to 1 requires a special interrupt processing that performs bank switching to the on-chip program storage area. Therefore, before issuing a download request (SCO = 1), set VBR to H'84000000. Otherwise, the CPU gets out of control. Once download end is confirmed, VBR can be changed to any other value.</p> <p>The mode in which the FWE pin is high must be used when using the SCO function.</p> <p>0: Download of the on-chip programming/erasing program to the on-chip RAM is not executed.</p> <p>[Clearing condition]</p> <p>When download is completed</p> <p>1: Request that the on-chip programming/erasing program is downloaded to the on-chip RAM is generated</p> <p>[Setting conditions]</p> <p>When all of the following conditions are satisfied and 1 is written to this bit</p> <ul style="list-style-type: none"> <li>• FKEY is written to H'A5</li> <li>• During execution in the on-chip RAM</li> </ul>



## (2) Flash Program Code Select Register (FPCS)

FPCS selects the on-chip programming program to be downloaded.

Bit:	7	6	5	4	3	2	1	0
	-	-	-	-	-	-	-	PPVS
Initial value:	0	0	0	0	0	0	0	0
R/W:	R	R	R	R	R	R	R	R/W

Bit	Bit Name	Initial Value	R/W	Description
7 to 1	—	All 0	R	Reserved These bits are always read as 0. The write value should always be 0.
0	PPVS	0	R/W	Program Pulse Single Selects the programming program. 0: On-chip programming program is not selected [Clearing condition] When transfer is completed 1: On-chip programming program is selected

## (3) Flash Erase Code Select Register (FECS)

FECS selects download of the on-chip erasing program.

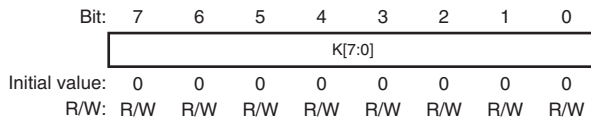
Bit:	7	6	5	4	3	2	1	0
	-	-	-	-	-	-	-	EPVB
Initial value:	0	0	0	0	0	0	0	0
R/W:	R	R	R	R	R	R	R	R/W

Bit	Bit Name	Initial Value	R/W	Description
7 to 1	—	All 0	R	Reserved These bits are always read as 0. The write value should always be 0.

Bit	Bit Name	Initial Value	R/W	Description
0	EPVB	0	R/W	<p>Erase Pulse Verify Block</p> <p>Selects the erasing program.</p> <p>0: On-chip erasing program is not selected [Clearing condition]</p> <p>When transfer is completed</p> <p>1: On-chip erasing program is selected</p>

#### (4) Flash Key Code Register (FKEY)

FKEY is a register for software protection that enables download of the on-chip program and programming/erasing of flash memory. Before setting the SCO bit to 1 in order to download the on-chip program or executing the downloaded programming/erasing program, these processings cannot be executed if the key code is not written.

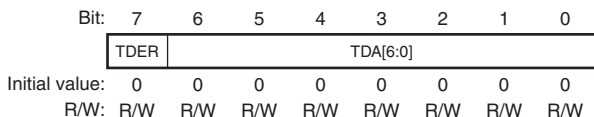


Bit	Bit Name	Initial Value	R/W	Description
7 to 0	K[7:0]	All 0	R/W	<p>Key Code</p> <p>Only when H'A5 is written, writing to the SCO bit is valid. When a value other than H'A5 is written to FKEY, 1 cannot be written to the SCO bit. Therefore downloading to the on-chip RAM cannot be executed.</p> <p>Only when H'5A is written, programming/erasing of flash memory can be executed. Even if the on-chip programming/erasing program is executed, flash memory cannot be programmed or erased when a value other than H'5A is written to FKEY.</p> <p>H'A5: Writing to the SCO bit is enabled (The SCO bit cannot be set by a value other than H'A5.)</p> <p>H'5A: Programming/erasing is enabled (A value other than H'5A enables software protection state.)</p> <p>H'00: Initial value</p>

## (5) Flash Transfer Destination Address Register (FTDAR)

FTDAR specifies the on-chip RAM address to which the on-chip program is downloaded.

Make settings for FTDAR before writing 1 to the SCO bit in FCCS. The initial value is H'00.



Bit	Bit Name	Initial Value	R/W	Description
7	TDER	0	R/W	<p>Transfer Destination Address Setting Error</p> <p>This bit is set to 1 when there is an error in the download start address set by bits 6 to 0 (TDA6 to TDA0). Whether the address setting is erroneous or not is tested by checking whether the setting of TDA6 to TDA0 is between the range of H'02 to H'04 after setting the SCO bit in FCCS to 1 and performing download. Before setting the SCO bit to 1 be sure to set the FTDAR value between H'02 to H'04 as well as clearing this bit to 0.</p> <p>0: Setting of TDA6 to TDA0 is normal</p> <p>1: Setting of TDER and TDA6 to TDA0 is H'00 to H'01 and H'05 to H'FF and download has been aborted</p>

Bit	Bit Name	Initial Value	R/W	Description
6 to 0	TDA[6:0]	All 0	R/W	<p>Transfer Destination Address</p> <p>These bits specify the download start address. A value from H'02 to H'04 can be set to specify the download start address in on-chip RAM in 2-kbyte units.</p> <p>A value H'00, H'01, or H'05 to H'7F cannot be set. If such a value is set, the TDER bit (bit 7) in this register is set to 1 to prevent download from being executed.</p> <p>H'02: Download start address is set to H'FFFA000  H'03: Download start address is set to H'FFFA800  H'04: Download start address is set to H'FFFB000  H'00, H'01, H'05 to H'7F: Setting prohibited when downloading by the SCO bit with user program mode. If this value is set, the TDER bit (bit 7) is set to 1 to abort the download processing. When not using user program mode, setting H'00 to the TDA is no problem.</p>

### 17.4.3 Programming/Erasing Interface Parameters

The programming/erasing interface parameters specify the operating frequency, user branch destination address, storage place for program data, programming destination address, and erase block and exchanges the processing result for the downloaded on-chip program. This parameter uses the general registers of the CPU (R4, R5, and R0) or the on-chip RAM area. The initial value is undefined.

At download all CPU registers are stored, and at initialization or when the on-chip program is executed, CPU registers except for R0 are stored. The return value of the processing result is written in R0. Since the stack area is used for storing the registers or as a work area, the stack area must be saved at the processing start. (The maximum size of a stack area to be used is 128 bytes.)

The programming/erasing interface parameters are used in the following four items.

1. Download control
2. Initialization before programming or erasing
3. Programming
4. Erasing

These items use different parameters. The correspondence table is shown in table 17.6.

The processing results of initialization, programming, and erasing are returned, but the bit contents have different meanings according to the processing program. See the description of FPFR for each processing.

**Table 17.6 Usable Parameters and Target Modes**

Name of Parameter	Abbreviation	Download	Initiali- zation	Pro- gram- ming	Erase	R/W	Initial Value	Allocation
Download pass/fail result	DPFR	√	—	—	—	R/W	Undefined	On-chip RAM*
Flash pass/fail result	FPFR	—	√	√	√	R/W	Undefined	R0 of CPU
Flash programming/ erasing frequency control	FPEFEQ	—	√	—	—	R/W	Undefined	R4 of CPU
Flash user branch address set	FUBRA	—	√	—	—	R/W	Undefined	R5 of CPU
Flash multipurpose address area	FMPAR	—	—	√	—	R/W	Undefined	R5 of CPU
Flash multipurpose data destination area	FMPDR	—	—	√	—	R/W	Undefined	R4 of CPU
Flash erase block select	FEBS	—	—	—	√	R/W	Undefined	R4 of CPU

Note: \* One byte of start address of download destination specified by FTDAR

## (1) Download Control

The on-chip program is automatically downloaded by setting the SCO bit to 1. The on-chip RAM area to be downloaded is the area as much as 3 Kbytes starting from the start address specified by FTDAR. For the address map of the on-chip RAM, see figure 17.10.

The download control is set by using the programming/erasing interface registers. The return value is given by the DPFRR parameter.

## (a) Download pass/fail result parameter (DPFRR: one byte of start address of on-chip RAM specified by FTDAR)

This parameter indicates the return value of the download result. The value of this parameter can be used to determine if downloading is executed or not. Since the confirmation whether the SCO bit is set to 1 is difficult, the certain determination must be performed by setting one byte of the start address of the on-chip RAM area specified by FTDAR to a value other than the return value of download (for example, H'FF) before the download start (before setting the SCO bit to 1). For the checking method of download results, see section 17.5.2 (2), Programming Procedure in User Program Mode.

Bit:	7	6	5	4	3	2	1	0
	-	-	-	-	-	SS	FK	SF
Initial value:	-	-	-	-	-	-	-	-
R/W:	R/W	R/W	R/W	R/W	R/W	R/W	R/W	R/W

Bit	Bit Name	Initial Value	R/W	Description
7 to 3	—	Undefined	R/W	Unused Return 0.
2	SS	Undefined	R/W	Source Select Error Detect  The on-chip program which can be downloaded can be specified as only one type. When more than two types of the program are selected, the program is not selected, or the program is selected without mapping, an error occurs.  0: Download program can be selected normally 1: Download error occurs (Multi-selection or program which is not mapped is selected)

Bit	Bit Name	Initial Value	R/W	Description
1	FK	Undefined	R/W	Flash Key Register Error Detect Returns the check result whether the value of FKEY is set to H'A5. 0: FKEY setting is normal (FKEY = H'A5) 1: FKEY setting is abnormal (FKEY = value other than H'A5)
0	SF	Undefined	R/W	Success/Fail Returns the result whether download has ended normally or not. 0: Downloading on-chip program has ended normally (no error) 1: Downloading on-chip program has ended abnormally (error occurs)

## (2) Programming/Erasing Initialization

The on-chip programming/erasing program to be downloaded includes the initialization program.

The specified period pulse must be applied when programming or erasing. The specified pulse width is made by the method in which wait loop is configured by the CPU instruction. The operating frequency of the CPU must be set. Since the user branch function is supported, the user branch destination address must be set.

The initial program is set as a parameter of the programming/erasing program which has downloaded these settings.

### (2.1) Flash programming/erasing frequency parameter (FPEFEQ: general register R4 of CPU)

This parameter sets the operating frequency of the CPU.

For the range of the operating frequency of this LSI, see section 21.3.1, Clock Timing.

Bit:	31	30	29	28	27	26	25	24	23	22	21	20	19	18	17	16
	-	-	-	-	-	-	-	-	-	-	-	-	-	-	-	-
Initial value:	-	-	-	-	-	-	-	-	-	-	-	-	-	-	-	-
R/W:	R/W	R/W	R/W	R/W	R/W	R/W	R/W	R/W	R/W	R/W	R/W	R/W	R/W	R/W	R/W	R/W
Bit:	15	14	13	12	11	10	9	8	7	6	5	4	3	2	1	0
	F15	F14	F13	F12	F11	F10	F9	F8	F7	F6	F5	F4	F3	F2	F1	F0
Initial value:	-	-	-	-	-	-	-	-	-	-	-	-	-	-	-	-
R/W:	R/W	R/W	R/W	R/W	R/W	R/W	R/W	R/W	R/W	R/W	R/W	R/W	R/W	R/W	R/W	R/W

Bit	Bit Name	Initial Value	R/W	Description
31 to 16	—	Undefined	R/W	Unused Return 0.
15 to 0	F15 to F0	Undefined	R/W	Frequency Set  Set the operating frequency of the CPU. The setting value must be calculated as the following methods.  1. The operating frequency, which is shown in MHz units must be rounded in a number to three decimal places and be shown in a number of two decimal places.  2. The centuplicated value is converted to the binary digit and is written to the FPEFEQ parameter (general register R4). For example, when the operating frequency of the CPU is 28.882 MHz, the value is as follows.  — The number to three decimal places of 28.882 is rounded and the value is thus 28.88.  — The formula that $28.88 \times 100 = 2888$ is converted to the binary digit and B'0000, B'1011, B'0100, B'1000 (H'0B48) is set to R4.

## (2.2) Flash user branch address setting parameter (FUBRA: general register R5 of CPU)

This parameter sets the user branch destination address. The user program which has been set can be executed in specified processing units when programming and erasing.

Bit:	31	30	29	28	27	26	25	24	23	22	21	20	19	18	17	16
	UA31	UA30	UA29	UA28	UA27	UA26	UA25	UA24	UA23	UA22	UA21	UA20	UA19	UA18	UA17	UA16
Initial value:	-	-	-	-	-	-	-	-	-	-	-	-	-	-	-	-
R/W:	R/W	R/W	R/W	R/W	R/W	R/W	R/W	R/W	R/W	R/W	R/W	R/W	R/W	R/W	R/W	R/W
Bit:	15	14	13	12	11	10	9	8	7	6	5	4	3	2	1	0
	UA15	UA14	UA13	UA12	UA11	UA10	UA9	UA8	UA7	UA6	UA5	UA4	UA3	UA2	UA1	UA0
Initial value:	-	-	-	-	-	-	-	-	-	-	-	-	-	-	-	-
R/W:	R/W	R/W	R/W	R/W	R/W	R/W	R/W	R/W	R/W	R/W	R/W	R/W	R/W	R/W	R/W	R/W



Bit	Bit Name	Initial Value	R/W	Description
31 to 0	UA31 to UA0	Undefined	R/W	<p>User Branch Destination Address</p> <p>When the user branch is not required, address 0 (H'84000000) must be set.</p> <p>The user branch destination must be an area other than the flash memory, an area other than the RAM area in which on-chip program has been transferred, or the external bus space.</p> <p>Note that the CPU must not branch to an area without the execution code and get out of control. The on-chip program download area and stack area must not be overwritten. If CPU runaway occurs or the download area or stack area is overwritten, the value of flash memory cannot be guaranteed.</p> <p>The download of the on-chip program, initialization, initiation of the programming/erasing program must not be executed in the processing of the user branch destination. Programming or erasing cannot be guaranteed when returning from the user branch destination. The program data which has already been prepared must not be programmed.</p> <p>Store general registers R8 to R15. General registers R0 to R7 are available without storing them.</p> <p>Moreover, the programming/erasing interface registers must not be written to in the processing of the user branch destination.</p> <p>After the processing of the user branch has ended, the programming/erasing program must be returned to by using the RTS instruction.</p> <p>For the execution intervals of the user branch processing, see note 2 (User Branch Processing Intervals) in section 17.7.2, Other Notes.</p>

## (2.3) Flash pass/fail result parameter (FPFR: general register R0 of CPU)

This parameter indicates the return value of the initialization result.

Bit:	31	30	29	28	27	26	25	24	23	22	21	20	19	18	17	16
	-	-	-	-	-	-	-	-	-	-	-	-	-	-	-	-
Initial value:	-	-	-	-	-	-	-	-	-	-	-	-	-	-	-	-
R/W:	R/W	R/W	R/W	R/W	R/W	R/W	R/W	R/W	R/W	R/W	R/W	R/W	R/W	R/W	R/W	R/W
Bit:	15	14	13	12	11	10	9	8	7	6	5	4	3	2	1	0
	-	-	-	-	-	-	-	-	-	-	-	-	-	BR	FQ	SF
Initial value:	-	-	-	-	-	-	-	-	-	-	-	-	-	-	-	-
R/W:	R/W	R/W	R/W	R/W	R/W	R/W	R/W	R/W	R/W	R/W	R/W	R/W	R/W	R/W	R/W	R/W

Bit	Bit Name	Initial Value	R/W	Description
31 to 3	—	Undefined	R/W	Unused Return 0.
2	BR	Undefined	R/W	User Branch Error Detect Returns the check result whether the specified user branch destination address is in the area other than the storage area of the programming/erasing program which has been downloaded. 0: User branch address setting is normal 1: User branch address setting is abnormal
1	FQ	Undefined	R/W	Frequency Error Detect Returns the check result whether the specified operating frequency of the CPU is in the range of the supported operating frequency. 0: Setting of operating frequency is normal 1: Setting of operating frequency is abnormal
0	SF	Undefined	R/W	Success/Fail Indicates whether initialization is completed normally. 0: Initialization has ended normally (no error) 1: Initialization has ended abnormally (error occurs)

### (3) Programming Execution

When flash memory is programmed, the programming destination address and programming data on the user MAT must be passed to the programming program in which the program data is downloaded.

1. The start address of the programming destination on the user MAT is set in general register R5 of the CPU. This parameter is called FMPAR (flash multipurpose address area parameter).

Since the program data is always in 128-byte units, the lower eight bits (MOA7 to MOA0) must be H'00 or H'80 as the boundary of the programming start address on the user MAT.

2. The program data for the user MAT must be prepared in the consecutive area. The program data must be in the consecutive space which can be accessed by using the MOV.B instruction of the CPU and is not the flash memory space.

When data to be programmed does not satisfy 128 bytes, the 128-byte program data must be prepared by embedding the dummy code (H'FF).

The start address of the area in which the prepared program data is stored must be set in general register R4. This parameter is called FMPDR (flash multipurpose data destination area parameter).

For details on the programming procedure, see section 17.5.2, User Program Mode (Only in On-Chip 128-Kbyte and 64-Kbyte ROM Version).

#### (3.1) Flash multipurpose address area parameter (FMPAR: general register R5 of CPU)

This parameter indicates the start address of the programming destination on the user MAT.

When an address in an area other than the flash memory space is set, an error occurs.

The start address of the programming destination must be at the 128-byte boundary. If this boundary condition is not satisfied, an error occurs. The error occurrence is indicated by the WA bit (bit 1) in FPCR.

Bit:	31	30	29	28	27	26	25	24	23	22	21	20	19	18	17	16
	MOA31	MOA30	MOA29	MOA28	MOA27	MOA26	MOA25	MOA24	MOA23	MOA22	MOA21	MOA20	MOA19	MOA18	MOA17	MOA16
Initial value:	-	-	-	-	-	-	-	-	-	-	-	-	-	-	-	-
R/W:	R/W	R/W	R/W	R/W	R/W	R/W	R/W	R/W	R/W	R/W	R/W	R/W	R/W	R/W	R/W	R/W

Bit:	15	14	13	12	11	10	9	8	7	6	5	4	3	2	1	0
	MOA15	MOA14	MOA13	MOA12	MOA11	MOA10	MOA9	MOA8	MOA7	MOA6	MOA5	MOA4	MOA3	MOA2	MOA1	MOA0
Initial value:	-	-	-	-	-	-	-	-	-	-	-	-	-	-	-	-
R/W:	R/W	R/W	R/W	R/W	R/W	R/W	R/W	R/W	R/W	R/W	R/W	R/W	R/W	R/W	R/W	R/W

Bit	Bit Name	Initial Value	R/W	Description
31 to 0	MOA31 to MOA0	Undefined	R/W	MOA31 to MOA0 Store the start address of the programming destination on the user MAT. The consecutive 128-byte programming is executed starting from the specified start address of the user MAT. The MOA6 to MOA0 bits are always 0 because the start address of the programming destination is at the 128-byte boundary.

### (3.2) Flash multipurpose data destination area parameter (FMPDR: general register R4 of CPU)

This parameter indicates the start address in the area which stores the data to be programmed in the user MAT. When the storage destination of the program data is in flash memory, an error occurs. The error occurrence is indicated by the WD bit (bit 2) in FPFRR.

Bit:	31	30	29	28	27	26	25	24	23	22	21	20	19	18	17	16
	MOD31	MOD30	MOD29	MOD28	MOD27	MOD26	MOD25	MOD24	MOD23	MOD22	MOD21	MOD20	MOD19	MOD18	MOD17	MOD16
Initial value:	-	-	-	-	-	-	-	-	-	-	-	-	-	-	-	-
R/W:	R/W	R/W	R/W	R/W	R/W	R/W	R/W	R/W	R/W	R/W	R/W	R/W	R/W	R/W	R/W	R/W
Bit:	15	14	13	12	11	10	9	8	7	6	5	4	3	2	1	0
	MOD15	MOD14	MOD13	MOD12	MOD11	MOD10	MOD9	MOD8	MOD7	MOD6	MOD5	MOD4	MOD3	MOD2	MOD1	MOD0
Initial value:	-	-	-	-	-	-	-	-	-	-	-	-	-	-	-	-
R/W:	R/W	R/W	R/W	R/W	R/W	R/W	R/W	R/W	R/W	R/W	R/W	R/W	R/W	R/W	R/W	R/W

Bit	Bit Name	Initial Value	R/W	Description
31 to 0	MOD31 to MOD0	Undefined	R/W	MOD31 to MOD0 Store the start address of the area which stores the program data for the user MAT. The consecutive 128-byte data is programmed to the user MAT starting from the specified start address.

## (3.3) Flash pass/fail parameter (FPFR: general register R0 of CPU)

This parameter indicates the return value of the program processing result.

Bit:	31	30	29	28	27	26	25	24	23	22	21	20	19	18	17	16
	-	-	-	-	-	-	-	-	-	-	-	-	-	-	-	-
Initial value:	-	-	-	-	-	-	-	-	-	-	-	-	-	-	-	-
R/W:	R/W	R/W	R/W	R/W	R/W	R/W	R/W	R/W	R/W	R/W	R/W	R/W	R/W	R/W	R/W	R/W
Bit:	15	14	13	12	11	10	9	8	7	6	5	4	3	2	1	0
	-	-	-	-	-	-	-	-	-	MD	EE	FK	-	WD	WA	SF
Initial value:	-	-	-	-	-	-	-	-	-	-	-	-	-	-	-	-
R/W:	R/W	R/W	R/W	R/W	R/W	R/W	R/W	R/W	R/W	R/W	R/W	R/W	R/W	R/W	R/W	R/W

Bit	Bit Name	Initial Value	R/W	Description
31 to 7	—	Undefined	R/W	Unused Return 0.
6	MD	Undefined	R/W	<p>Programming Mode Related Setting Error Detect</p> <p>Returns the check result of whether the signal input to the FWE pin is high and whether the error protection state is not entered.</p> <p>When a low-level signal is input to the FWE pin or the error protection state is entered, 1 is written to this bit. The input level to the FWE pin and the error protection state can be confirmed with the FWE bit (bit 7) and the FLER bit (bit 4) in FCCS, respectively. For conditions to enter the error protection state, see section 17.6.3, Error Protection.</p> <p>0: FWE and FLER settings are normal (FWE = 1, FLER = 0)</p> <p>1: FWE = 0 or FLER = 1, and programming cannot be performed</p>

Bit	Bit Name	Initial Value	R/W	Description
5	EE	Undefined	R/W	<p>Programming Execution Error Detect</p> <p>1 is returned to this bit when the specified data could not be written because the user MAT was not erased or when flash-memory related register settings are partially changed on returning from the user branch processing.</p> <p>If this bit is set to 1, there is a high possibility that the user MAT is partially rewritten. In this case, after removing the error factor, erase the user MAT.</p> <p>0: Programming has ended normally 1: Programming has ended abnormally (programming result is not guaranteed)</p>
4	FK	Undefined	R/W	<p>Flash Key Register Error Detect</p> <p>Returns the check result of the value of FKEY before the start of the programming processing.</p> <p>0: FKEY setting is normal (FKEY = H'5A) 1: FKEY setting is error (FKEY = value other than H'5A)</p>
3	—	Undefined	R/W	<p>Unused</p> <p>Return 0.</p>
2	WD	Undefined	R/W	<p>Write Data Address Error Detect</p> <p>When an address in the flash memory area is specified as the start address of the storage destination of the program data, an error occurs.</p> <p>0: Setting of write data address is normal 1: Setting of write data address is abnormal</p>
1	WA	Undefined	R/W	<p>Write Address Error Detect</p> <p>When the following items are specified as the start address of the programming destination, an error occurs.</p> <ul style="list-style-type: none"> <li>The programming destination address is an area other than flash memory</li> <li>The specified address is not at the 128-byte boundary (A6 to A0 are not 0)</li> </ul> <p>0: Setting of programming destination address is normal 1: Setting of programming destination address is abnormal</p>

Bit	Bit Name	Initial Value	R/W	Description
0	SF	Undefined	R/W	Success/Fail Indicates whether the program processing has ended normally or not. 0: Programming has ended normally (no error) 1: Programming has ended abnormally (error occurs)

#### (4) Erasure Execution

When flash memory is erased, the erase-block number on the user MAT must be passed to the erasing program which is downloaded. This is set to the FEBS parameter (general register R4). One block is specified from the block number 0 to 15.

For details on the erasing procedure, see section 17.5.2, User Program Mode (Only in On-Chip 128-Kbyte and 64-Kbyte ROM Version).

##### (4.1) Flash erase block select parameter (FEBS: general register R4 of CPU)

This parameter specifies the erase-block number. Several block numbers cannot be specified.

Bit:	31	30	29	28	27	26	25	24	23	22	21	20	19	18	17	16
	-	-	-	-	-	-	-	-	-	-	-	-	-	-	-	-
Initial value:	-	-	-	-	-	-	-	-	-	-	-	-	-	-	-	-
R/W:	R/W	R/W	R/W	R/W	R/W	R/W	R/W	R/W	R/W	R/W	R/W	R/W	R/W	R/W	R/W	R/W
Bit:	15	14	13	12	11	10	9	8	7	6	5	4	3	2	1	0
	-	-	-	-	-	-	-	-	EBS[7:0]							
Initial value:	-	-	-	-	-	-	-	-	-							
R/W:	R/W	R/W	R/W	R/W	R/W	R/W	R/W	R/W	R/W	R/W	R/W	R/W	R/W	R/W	R/W	R/W

Bit	Bit Name	Initial Value	R/W	Description
31 to 8	—	Undefined	R/W	Unused Return 0.
7 to 0	EBS[7:0]	Undefined	R/W	<ul style="list-style-type: none"> <li>128-kbyte flash memory Set the erase-block number in the range from 0 to 9. 0 corresponds to the EB0 block and 9 corresponds to the EB9 block. An error occurs when a number other than 0 to 9 (H'00 to H'09) is set.</li> <li>64-kbyte flash memory Set the erase-block number in the range from 0 to 8. 0 corresponds to the EB0 block and 8 corresponds to the EB8 block. An error occurs when a number other than 0 to 8 (H'00 to H'08) is set.</li> </ul>

#### (4.2) Flash pass/fail result parameter (FPFR: general register R0 of CPU)

This parameter returns the value of the erasing processing result.

Bit:	31	30	29	28	27	26	25	24	23	22	21	20	19	18	17	16
	-	-	-	-	-	-	-	-	-	-	-	-	-	-	-	-
Initial value:	-	-	-	-	-	-	-	-	-	-	-	-	-	-	-	-
R/W:	R/W	R/W	R/W	R/W	R/W	R/W	R/W	R/W	R/W	R/W	R/W	R/W	R/W	R/W	R/W	R/W
Bit:	15	14	13	12	11	10	9	8	7	6	5	4	3	2	1	0
	-	-	-	-	-	-	-	-	-	MD	EE	FK	EB	-	-	SF
Initial value:	-	-	-	-	-	-	-	-	-	-	-	-	-	-	-	-
R/W:	R/W	R/W	R/W	R/W	R/W	R/W	R/W	R/W	R/W	R/W	R/W	R/W	R/W	R/W	R/W	R/W

Bit	Bit Name	Initial Value	R/W	Description
31 to 7	—	Undefined	R/W	Unused Return 0.



Bit	Bit Name	Initial Value	R/W	Description
6	MD	Undefined	R/W	<p>Erasure Mode Related Setting Error Detect</p> <p>Returns the check result of whether the signal input to the FWE pin is high and whether the error protection state is not entered.</p> <p>When a low-level signal is input to the FWE pin or the error protection state is entered, 1 is written to this bit. The input level to the FWE pin and the error protection state can be confirmed with the FWE bit (bit 7) and the FLER bit (bit 4) in FCCS, respectively. For conditions to enter the error protection state, see section 17.6.3, Error Protection.</p> <p>0: FWE and FLER settings are normal (FWE = 1, FLER = 0)</p> <p>1: FWE = 0 or FLER = 1, and erasure cannot be performed</p>
5	EE	Undefined	R/W	<p>Erasure Execution Error Detect</p> <p>1 is returned to this bit when the user MAT could not be erased or when flash-memory related register settings are partially changed on returning from the user branch processing.</p> <p>If this bit is set to 1, there is a high possibility that the user MAT is partially erased. In this case, after removing the error factor, erase the user MAT.</p> <p>0: Erasure has ended normally</p> <p>1: Erasure has ended abnormally (erasure result is not guaranteed)</p>
4	FK	Undefined	R/W	<p>Flash Key Register Error Detect</p> <p>Returns the check result of FKEY value before start of the erasing processing.</p> <p>0: FKEY setting is normal (FKEY = H'5A)</p> <p>1: FKEY setting is error (FKEY = value other than H'5A)</p>
3	EB	Undefined	R/W	<p>Erase Block Select Error Detect</p> <p>Returns the check result whether the specified erase-block number is in the block range of the user MAT.</p> <p>0: Setting of erase-block number is normal</p> <p>1: Setting of erase-block number is abnormal</p>

<b>Bit</b>	<b>Bit Name</b>	<b>Initial Value</b>	<b>R/W</b>	<b>Description</b>
2, 1	—	Undefined	R/W	Unused Return 0.
0	SF	Undefined	R/W	Success/Fail Indicates whether the erasing processing has ended normally or not. 0: Erasure has ended normally (no error) 1: Erasure has ended abnormally (error occurs)

---

## 17.5 On-Board Programming Mode

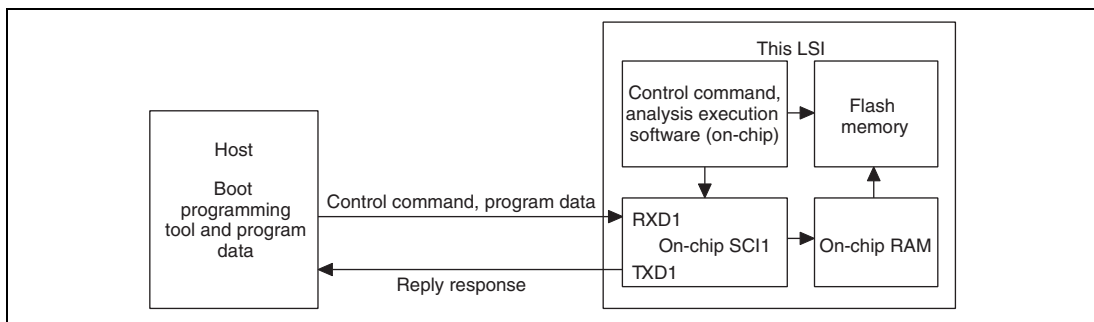
When the pin is set in on-board programming mode and the reset start is executed, the on-board programming state that can program/erase the on-chip flash memory is entered. On-board programming mode has two operating modes: user program mode and boot mode.

For details on the pin setting for entering each mode, see table 17.1. For details on the state transition of each mode for flash memory, see figure 17.2.

### 17.5.1 Boot Mode

Boot mode executes programming/erasing user MAT by means of the control command and program data transmitted from the host using the on-chip SCI. The tool for transmitting the control command and program data must be prepared in the host. The SCI communication mode is set to asynchronous mode. When reset start is executed after this LSI's pin is set in boot mode, the boot program in the microcomputer is initiated. After the SCI bit rate is automatically adjusted, the communication with the host is executed by means of the control command method.

The system configuration diagram in boot mode is shown in figure 17.6. For details on the pin setting in boot mode, see table 17.1. Although NMI and other interrupts are ignored in boot mode, do not generate them.

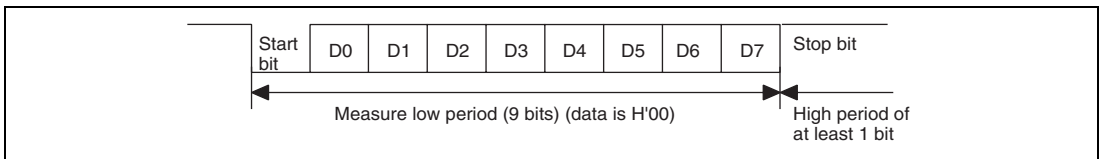


**Figure 17.6 System Configuration in Boot Mode**

## (1) SCI Interface Setting by Host

When boot mode is initiated, this LSI measures the low period of asynchronous SCI-communication data (H'00), which is transmitted consecutively by the host. The SCI transmit/receive format is set to 8-bit data, 1 stop bit, and no parity. This LSI calculates the bit rate of transmission by the host by means of the measured low period and transmits the bit adjustment end sign (1 byte of H'00) to the host. The host must confirm that this bit adjustment end sign (H'00) has been received normally and transmits 1 byte of H'55 to this LSI. When reception is not executed normally, boot mode is initiated again (reset) and the operation described above must be executed. The bit rate between the host and this LSI is not matched because of the bit rate of transmission by the host and system clock frequency of this LSI. To operate the SCI normally, the transfer bit rate of the host must be set to 9,600 bps or 19,200 bps.

The system clock frequency, which can automatically adjust the transfer bit rate of the host and the bit rate of this LSI is shown in table 17.7. Boot mode must be initiated in the range of this system clock. Note that the internal clock division ratio of  $\times 1/3$  is not supported in boot mode.



**Figure 17.7 Automatic Adjustment Operation of SCI Bit Rate**

**Table 17.7 Peripheral Clock (P $\phi$ ) Frequency that Can Automatically Adjust Bit Rate of This LSI**

Host Bit Rate	Peripheral Clock (P $\phi$ ) Frequency Which Can Automatically Adjust LSI's Bit Rate
9,600 bps	20 to 25 MHz
19,200 bps	20 to 25 MHz

Note: The internal clock division ratio of  $\times 1/3$  is not supported in boot mode.

## (2) State Transition Diagram

Figure 17.8 gives an overview of the state transitions after the chip has been started up in boot mode. For details on boot mode, see section 17.8.1, Specifications of the Standard Serial Communications Interface in Boot Mode.

### 1. Bit-rate matching

After the chip has been started up in boot mode, bit-rate matching between the SCI and the host proceeds.

### 2. Waiting for inquiry and selection commands

The chip sends the requested information to the host in response to inquiries regarding the size and configuration of the user MAT, start addresses of the MATs, information on supported devices, etc.

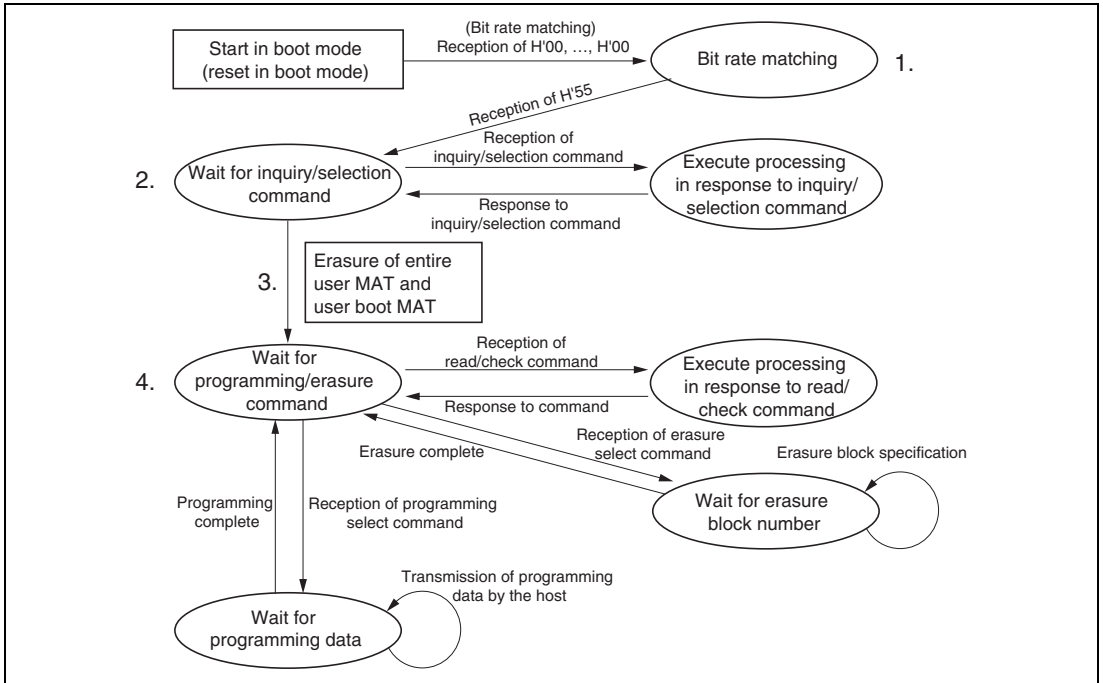
### 3. Automatic erasure of the entire user MAT

After all necessary inquiries and selections have been made and the command for transition to the programming/erasure state is sent by the host, the entire user MAT is automatically erased.

### 4. Waiting for programming/erasure command

- On receiving the programming selection command, the chip waits for data to be programmed. To program data, the host transmits the programming command code followed by the address where programming should start and the data to be programmed. This is repeated as required while the chip is in the programming-selected state. To terminate programming, H'FFFFFFFF should be transmitted as the first address of the area for programming. This makes the chip return to the programming/erasure command waiting state from the programming data waiting state.
- On receiving the erasure select command, the chip waits for the block number of a block to be erased. To erase a block, the host transmits the erasure command code followed by the number of the block to be erased. This is repeated as required while the chip is in the erasure-selected state. To terminate erasure, H'FF should be transmitted as the block number. This makes the chip return to the programming/erasure command waiting state from the erasure block number waiting state. Erasure should only be executed when a specific block is to be reprogrammed without executing a reset-start of the chip after the flash memory has been programmed in boot mode. If all desired programming is done in a single operation, such erasure processing is not necessary because all blocks are erased before the chip enters the programming/erasure/other command waiting state.
- In addition to the programming and erasure commands, commands for sum checking and blank checking (checking for erasure) of the user MAT, reading data from the user MAT, and acquiring current state information are provided.

Note that the command for reading from the user MAT can only read data that has been programmed after automatic erasure of the entire user MAT.



**Figure 17.8 State Transitions in Boot Mode**

## 17.5.2 User Program Mode (Only in On-Chip 128-Kbyte and 64-Kbyte ROM Version)

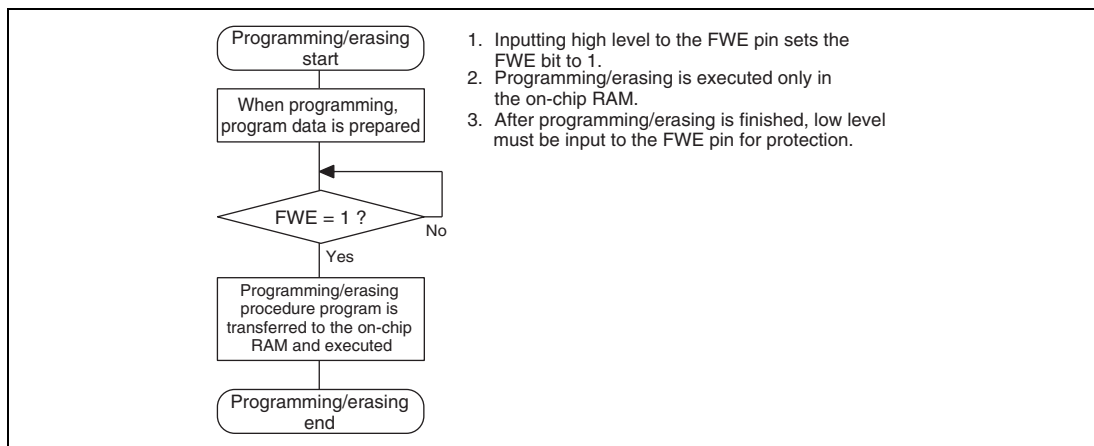
The user MAT can be programmed/erased in user program mode.

Programming/erasing is executed by downloading the program in the microcomputer.

The overview flow is shown in figure 17.9.

High voltage is applied to internal flash memory during the programming/erasing processing. Therefore, transition to reset must not be executed. Doing so may cause damage or destroy flash memory. If reset is executed accidentally, the reset signal must be released after the reset input period, which is longer than the normal 100  $\mu$ s.

For details on the programming procedure, see the description in section 17.5.2 (2), Programming Procedure in User Program Mode. For details on the erasing procedure, see the description in section 17.5.2 (3), Erasing Procedure in User Program Mode.

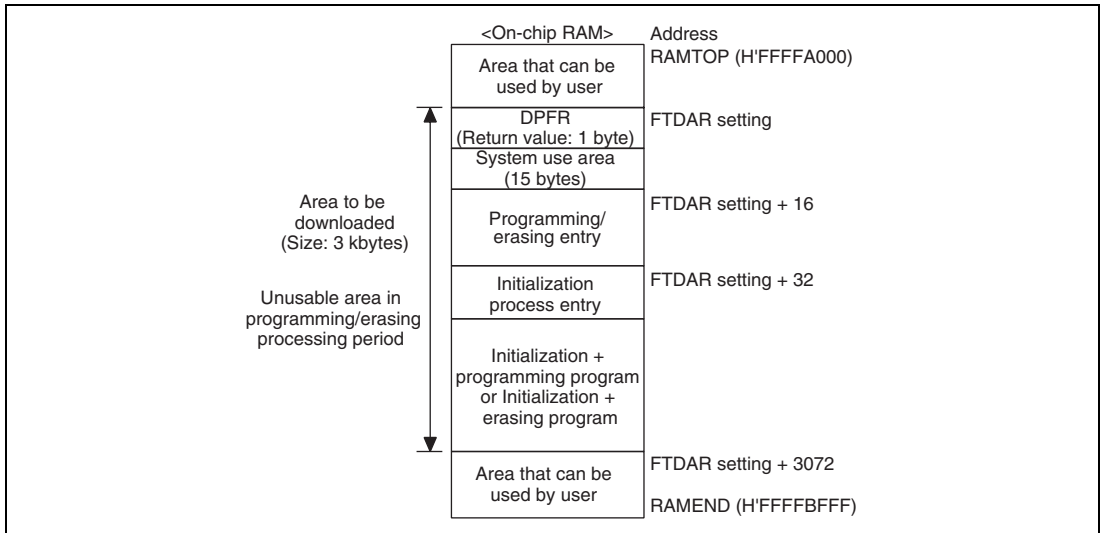


**Figure 17.9 Programming/Erasing Overview Flow**

## (1) On-Chip RAM Address Map when Programming/Erasing is Executed

Parts of the procedure program that are made by the user, like download request, programming/erasing procedure, and decision of the result, must be executed in the on-chip RAM. All of the on-chip program that is to be downloaded is in on-chip RAM. Note that on-chip RAM must be controlled so that these parts do not overlap.

Figure 17.10 shows the program area to be downloaded.

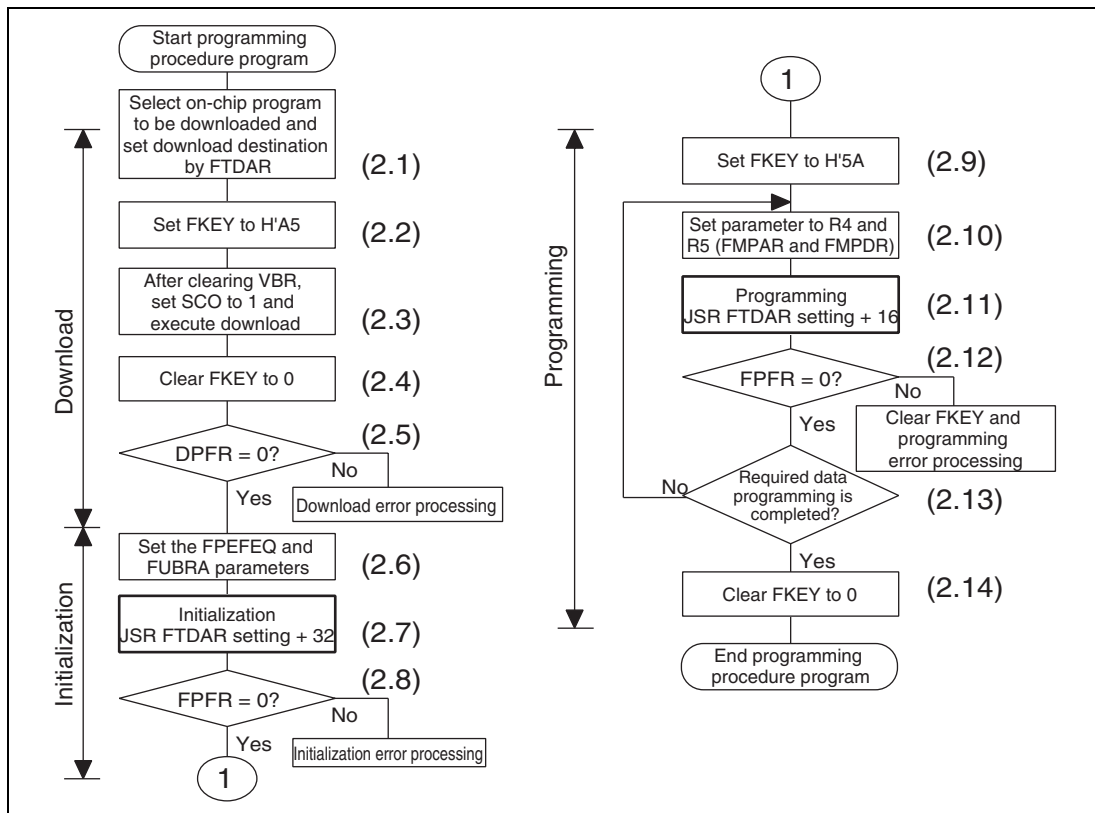


**Figure 17.10 RAM Map after Download**



## (2) Programming Procedure in User Program Mode

The procedures for download, initialization, and programming are shown in figure 17.11.



**Figure 17.11 Programming Procedure**

The details of the programming procedure are described below. The procedure program must be executed in an area other than the flash memory to be programmed. Especially the part where the SCO bit in FCCS is set to 1 for downloading must be executed in the on-chip RAM. Specify 1/4 (initial value) as the frequency division ratios of an internal clock ( $I\phi$ ), a bus clock ( $B\phi$ ), and a peripheral clock ( $P\phi$ ) through the frequency control register (FRQCR).

After the programming/erasing program has been downloaded and the SCO bit is cleared to 0, the setting of the frequency control register (FRQCR) can be changed to the desired value. The following description assumes the area to be programmed on the user MAT is erased and program data is prepared in the consecutive area. When erasing has not been executed, carry out erasing before writing.

128-byte programming is performed in one program processing. When more than 128-byte programming is performed, programming destination address/program data parameter is updated in 128-byte units and programming is repeated.

When less than 128-byte programming is performed, data must total 128 bytes by adding the invalid data. If the invalid data to be added is H'FF, the program processing period can be shortened.

(2.1) Select the on-chip program to be downloaded

When the PPVS bit of FPCS is set to 1, the programming program is selected.

Several programming/erasing programs cannot be selected at one time. If several programs are set, download is not performed and a download error is returned to the source select error detect (SS) bit in the DPFR parameter.

Specify the start address of the download destination by FTDAR.

(2.2) Write H'A5 in FKEY

If H'A5 is not written to FKEY for protection, 1 cannot be written to the SCO bit for a download request.

(2.3) VBR is set to 0 and 1 is written to the SCO bit of FCCS, and then download is executed.

VBR must always be set to H'84000000 before setting the SCO bit to 1.

To write 1 to the SCO bit, the following conditions must be satisfied.

- H'A5 is written to FKEY.
- The SCO bit writing is executed in the on-chip RAM.

When the SCO bit is set to 1, download is started automatically. When execution returns to the user procedure program, the SCO bit is cleared to 0. Therefore, the SCO bit cannot be confirmed to be 1 in the user procedure program.

The download result can be confirmed only by the return value of the DPFR parameter. Before the SCO bit is set to 1, incorrect decision must be prevented by setting the DPFR parameter, that is one byte of the start address of the on-chip RAM area specified by FTDAR, to a value other than the return value (H'FF).

When download is executed, particular interrupt processing, which is accompanied by the bank switch as described below, is performed as an internal microcomputer processing, so VBR need to be set to H'84000000. Four NOP instructions are executed immediately after the instructions that set the SCO bit to 1.

- The user MAT space is switched to the on-chip program storage area.
- After the selection condition of the download program and the address set in FTDAR are checked, the transfer processing is executed starting to the on-chip RAM address specified by FTDAR.
- The SCO bits in FCCS, FPCS, and FECS are cleared to 0.
- The return value is set to the DPFR parameter.

- After the on-chip program storage area is returned to the user MAT space, execution returns to the user procedure program.

After download is completed and the user procedure program is running, the VBR setting can be changed.

The notes on download are as follows.

In the download processing, the values of the general registers of the CPU are retained.

During the download processing, interrupts must not be generated. For details on the relationship between download and interrupts, see section 17.7.1, Interrupts during Programming/Erasing.

Since a stack area of maximum 128 bytes is used, an area of at least 128 bytes must be saved before setting the SCO bit to 1.

(2.4) FKEY is cleared to H'00 for protection.

(2.5) The value of the DPFR parameter must be checked to confirm the download result.

A recommended procedure for confirming the download result is shown below.

- Check the value of the DPFR parameter (one byte of start address of the download destination specified by FTDAR). If the value is H'00, download has been performed normally. If the value is not H'00, the source that caused download to fail can be investigated by the description below.
- If the value of the DPFR parameter is the same as before downloading (e.g. H'FF), the address setting of the download destination in FTDAR may be abnormal. In this case, confirm the setting of the TDER bit (bit 7) in FTDAR.
- If the value of the DPFR parameter is different from before downloading, check the SS bit (bit 2) and the FK bit (bit 1) in the DPFR parameter to ensure that the download program selection and FKEY register setting were normal, respectively.

(2.6) The operating frequency is set to the FPEFEQ parameter and the user branch destination is set to the FUBRA parameter for initialization.

- The current frequency of the CPU clock is set to the FPEFEQ parameter (general register R4). For the settable range of the FPEFEQ parameter, see section 21.3.1, Clock Timing.

When the frequency is set out of this range, an error is returned to the FPFPR parameter of the initialization program and initialization is not performed. For details on the frequency setting, see the description in section 17.4.3 (2.1), Flash programming/erasing frequency parameter (FPEFEQ: general register R4 of CPU).

- The start address in the user branch destination is set to the FUBRA parameter (general register R5).

When the user branch processing is not required, 0 must be set to FUBRA.

When the user branch is executed, the branch destination is executed in flash memory other than the one that is to be programmed. The area of the on-chip program that is downloaded cannot be set.

The program processing must be returned from the user branch processing by the RTS instruction.

See the description in section 17.4.3 (2.2), Flash user branch address setting parameter (FUBRA: general register R5 of CPU).

### (2.7) Initialization

When a programming program is downloaded, the initialization program is also downloaded to on-chip RAM. There is an entry point of the initialization program in the area from (download start address set by FTDAR) + 32 bytes. The subroutine is called and initialization is executed by using the following steps.

```
MOV.L #DLTOP+32,R1      ; Set entry address to R1
JSR   @R1              ; Call initialization routine
NOP
```

- The general registers other than R0 are saved in the initialization program.
- R0 is a return value of the FPFR parameter.
- Since the stack area is used in the initialization program, a stack area of maximum 128 bytes must be reserved in RAM.
- Interrupts can be accepted during the execution of the initialization program. However, the program storage area and stack area in on-chip RAM and register values must not be destroyed.

(2.8) The return value of the initialization program, FPFR (general register R0) is checked.

(2.9) FKEY must be set to H'5A and the user MAT must be prepared for programming.

(2.10) The parameter which is required for programming is set.

The start address of the programming destination of the user MAT (FMPAR) is set to general register R5. The start address of the program data storage area (FMPDR) is set to general register R4.

- FMPAR setting

FMPAR specifies the programming destination start address. When an address other than one in the user MAT area is specified, even if the programming program is executed, programming is not executed and an error is returned to the return value

parameter FPF<sub>R</sub>. Since the unit is 128 bytes, the lower eight bits (MOA<sub>7</sub> to MOA<sub>0</sub>) must be in the 128-byte boundary of H'00 or H'80.

- FMPDR setting

If the storage destination of the program data is flash memory, even when the program execution routine is executed, programming is not executed and an error is returned to the FPF<sub>R</sub> parameter. In this case, the program data must be transferred to on-chip RAM and then programming must be executed.

### (2.11) Programming

There is an entry point of the programming program in the area from (download start address set by FTDAR) + 16 bytes of on-chip RAM. The subroutine is called and programming is executed by using the following steps.

```
MOV.L #DLTOP+16,R1      ; Set entry address to R1
JSR   @R1               ; Call programming routine
NOP
```

— The general registers other than R0 are saved in the programming program.

— R0 is a return value of the FPF<sub>R</sub> parameter.

— Since the stack area is used in the programming program, a stack area of maximum 128 bytes must be reserved in RAM.

(2.12) The return value in the programming program, FPF<sub>R</sub> (general register R0) is checked.

(2.13) Determine whether programming of the necessary data has finished.

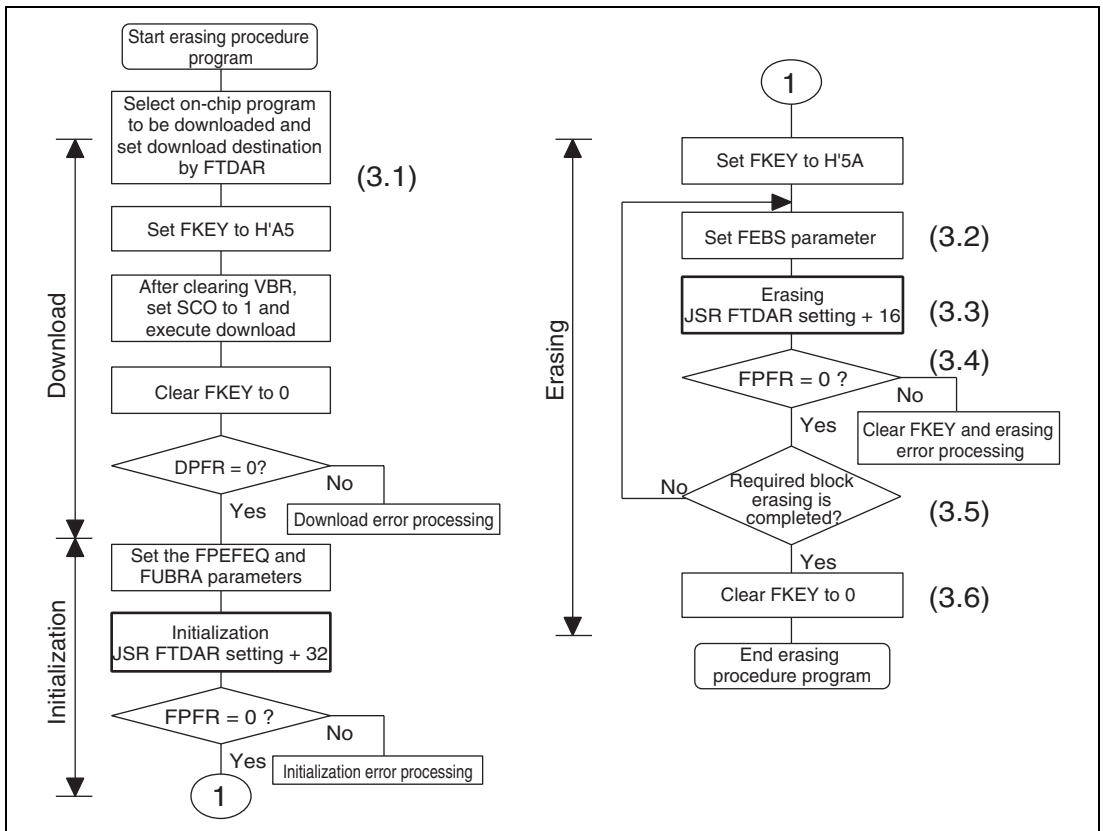
If more than 128 bytes of data are to be programmed, specify FMPAR and FMPDR in 128-byte units, and repeat steps (2.10) to (2.13). Increment the programming destination address by 128 bytes and update the programming data pointer correctly. If an address which has already been programmed is written to again, not only will a programming error occur, but also flash memory will be damaged.

(2.14) After programming finishes, clear FKEY and specify software protection.

If this LSI is restarted by a power-on reset immediately after user MAT programming has finished, secure a reset period (period of  $\overline{\text{RES}} = 0$ ) that is at least as long as the normal 100  $\mu\text{s}$ .

## (3) Erasing Procedure in User Program Mode

The procedures for download, initialization, and erasing are shown in figure 17.12.



**Figure 17.12 Erasing Procedure**

The details of the erasing procedure are described below. The procedure program must be executed in an area other than the user MAT to be erased.

Especially the part where the SCO bit in FCCS is set to 1 for downloading must be executed in on-chip RAM.

Specify 1/4 (initial value) as the frequency division ratios of an internal clock ( $I\phi$ ), a bus clock ( $B\phi$ ), and a peripheral clock ( $P\phi$ ) through the frequency control register (FRQCR).

After the programming/erasing program has been downloaded and the SCO bit is cleared to 0, the setting of the frequency control register (FRQCR) can be changed to the desired value. For the downloaded on-chip program area, see the RAM map for programming/erasing in figure 17.10.

A single divided block is erased by one erasing processing. For block divisions, see figure 17.4. To erase two or more blocks, update the erase block number and perform the erasing processing for each block.

(3.1) Select the on-chip program to be downloaded

Set the EPVB bit in FECS to 1.

Several programming/erasing programs cannot be selected at one time. If several programs are set, download is not performed and a download error is returned to the source select error detect (SS) bit in the DPFRR parameter.

Specify the start address of the download destination by FTDAR.

The procedures to be carried out after setting FKEY, e.g. download and initialization, are the same as those in the programming procedure. For details, see the description in section 17.5.2 (2), Programming Procedure in User Program Mode.

(3.2) Set the FEBS parameter necessary for erasure

Set the erase block number of the user MAT in the flash erase block select parameter (FEBS: general register R4). If a value other than an erase block number of the user MAT is set, no block is erased even though the erasing program is executed, and an error is returned to the return value parameter FPFR.

(3.3) Erasure

Similar to as in programming, there is an entry point of the erasing program in the area from (download start address set by FTDAR) + 16 bytes of on-chip RAM. The subroutine is called and erasing is executed by using the following steps.

```
MOV.L #DLTOP+16,R1      ; Set entry address to R1
JSR   @R1               ; Call erasing routine
NOP
```

— The general registers other than R0 are saved in the erasing program.

— R0 is a return value of the FPFR parameter.

— Since the stack area is used in the erasing program, a stack area of maximum 128 bytes must be reserved in RAM.

(3.4) The return value in the erasing program, FPFR (general register R0) is checked.

(3.5) Determine whether erasure of the necessary blocks has finished.

If more than one block is to be erased, update the FEBS parameter and repeat steps (3.2) to (3.5). Blocks that have already been erased can be erased again.

(3.6) After erasure finishes, clear FKEY and specify software protection.

If this LSI is restarted by a power-on reset immediately after user MAT erasing has finished, secure a reset period (period of  $\overline{RES} = 0$ ) that is at least as long as the normal 100  $\mu$ s.

## 17.6 Protection

There are three kinds of flash memory program/erase protection: hardware, software, and error protection.

### 17.6.1 Hardware Protection

Programming and erasing of flash memory is forcibly disabled or suspended by hardware protection. In this state, the downloading of an on-chip program and initialization of the flash memory are possible. However, an activated program for programming or erasure cannot program or erase locations in a user MAT, and the error in programming/erasing is reported in the FPF<sub>R</sub> parameter.

**Table 17.8 Hardware Protection**

Item	Description	Function to be Protected	
		Download	Programming/ Erasure
FWE-pin protection	The input of a low-level signal on the FWE pin clears the FWE bit of FCCS and the LSI enters a programming/erasing-protected state.	—	√
Reset/standby protection	<ul style="list-style-type: none"> <li>A power-on reset (including a power-on reset by the WDT) and entry to standby mode initializes the programming/erasing interface registers and the LSI enters a programming/erasing-protected state.</li> <li>Resetting by means of the <math>\overline{\text{RES}}</math> pin after power is initially supplied will not make the LSI enter the reset state unless the <math>\overline{\text{RES}}</math> pin is held low until oscillation has stabilized. In the case of a reset during operation, hold the <math>\overline{\text{RES}}</math> pin low for the <math>\overline{\text{RES}}</math> pulse width that is specified in the section on AC characteristics. If the LSI is reset during programming or erasure, data in the flash memory is not guaranteed. In this case, execute erasure and then execute programming again.</li> </ul>	√	√



## 17.6.2 Software Protection

Software protection is set up in any of two ways: by disabling the downloading of on-chip programs for programming and erasing and by means of a key code.

**Table 17.9 Software Protection**

Item	Description	Function to be Protected	
		Download	Programming/ Erasure
Protection by the SCO bit	Clearing the SCO bit in FCCS disables downloading of the programming/erasing program, thus making the LSI enter a programming/erasing-protected state.	√	√
Protection by FKEY	Downloading and programming/erasing are disabled unless the required key code is written in FKEY. Different key codes are used for downloading and for programming/erasing.	√	√

## 17.6.3 Error Protection

Error protection is a mechanism for aborting programming or erasure when an error occurs, in the form of the microcomputer getting out of control during programming/erasing of the flash memory or operations that are not in accordance with the established procedures for programming/erasing. Aborting programming or erasure in such cases prevents damage to the flash memory due to excessive programming or erasing.

If the microcomputer malfunctions during programming/erasing of the flash memory, the FLER bit in FCCS is set to 1 and the LSI enters the error protection state, thus aborting programming or erasure.

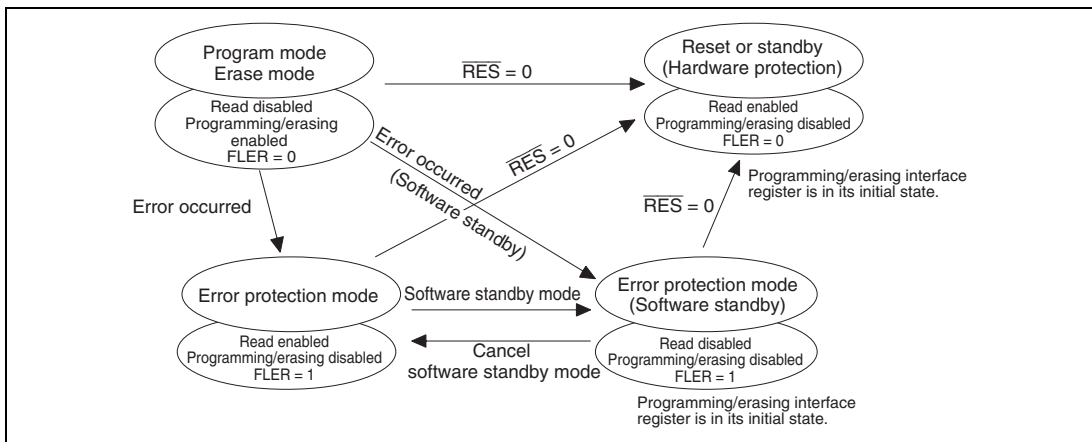
The FLER bit is set to 1 in the following conditions:

- When the relevant bank area of flash memory is read during programming/erasing (including a vector read or an instruction fetch)
- When a SLEEP instruction (including software standby mode) is executed during programming/erasing

Error protection is cancelled (FLER bit is cleared) only by a power-on reset.

Note that the reset signal should only be released after providing a reset input over a period longer than the normal 100  $\mu$ s. Since high voltages are applied during programming/erasing of the flash memory, some voltage may still remain even after the error protection state has been entered. For this reason, it is necessary to reduce the risk of damage to the flash memory by extending the reset period so that the charge is released.

The state-transition diagram in figure 17.13 shows transitions to and from the error protection state.



**Figure 17.13 Transitions to and from Error Protection State**

## 17.7 Usage Notes

### 17.7.1 Interrupts during Programming/Erasing

#### (1) Download of On-Chip Program

##### (1.1) VBR setting change

Before downloading the on-chip program, VBR must be set to H'84000000. If VBR is set to a value other than H'84000000, the interrupt vector table is placed in the user MAT on setting H'84000000 to VBR.

When VBR setting change conflicts with interrupt occurrence, whether the vector table before or after VBR is changed is referenced may cause an error.

Therefore, for cases where VBR setting change may conflict with interrupt occurrence, prepare a vector table to be referenced when VBR is H'00000000 (initial value) at the start of the user MAT.

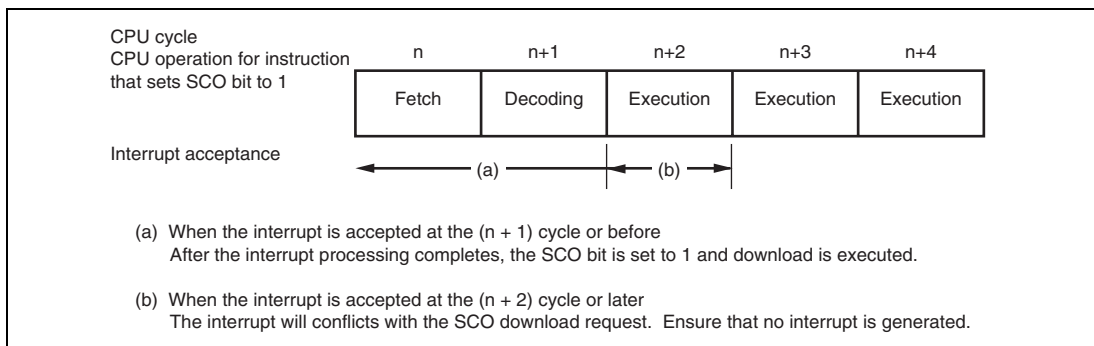
##### (1.2) SCO download request and interrupt request

Download of the on-chip programming/erasing program that is initiated by setting the SCO bit in FCCS to 1 generates a particular interrupt processing accompanied by MAT switchover.

Operation when the SCO download request and interrupt request conflicts is described below.

##### 1. Contention between SCO download request and interrupt request

Figure 17.14 shows the timing of contention between execution of the instruction that sets the SCO bit in FCCS to 1 and interrupt acceptance.



**Figure 17.14 Timing of Contention between SCO Download Request and Interrupt Request**

##### 2. Generation of interrupt requests during downloading

Ensure that interrupts are not generated during downloading that is initiated by the SCO bit.

## (2) Interrupts during programming/erasing

Though an interrupt processing can be executed at realtime during programming/erasing of the downloaded on-chip program, the following limitations and notes are applied.

1. When flash memory is being programmed or erased, the user MAT cannot be accessed.  
Prepare the interrupt vector table and interrupt processing routine in on-chip RAM. Make sure the flash memory being programmed or erased is not accessed by the interrupt processing routine. If flash memory is read, the read values are not guaranteed. If the relevant bank in flash memory that is being programmed or erased is accessed, the error protection state is entered, and programming or erasing is aborted. If a bank other than the relevant bank is accessed, the error protection state is not entered but the read values are not guaranteed.
2. Do not rewrite the program data specified by the FMPDR parameter. If new program data is to be provided by the interrupt processing, temporarily save the new program data in another area. After confirming the completion of programming, save the new program data in the area specified by FMPDR or change the setting in FMPDR to indicate the other area in which the new program data was temporarily saved.
3. Make sure the interrupt processing routine does not rewrite the contents of the flash-memory related registers or data in the downloaded on-chip program area. During the interrupt processing, do not simultaneously perform download of the on-chip program by an SCO request or programming/erasing.
4. At the beginning of the interrupt processing routine, save the CPU register contents. Before returning from the interrupt processing, write the saved contents in the CPU registers again.
5. When a transition is made to sleep mode or software standby mode in the interrupt processing routine, the error protection state is entered and programming/erasing is aborted.  
If a transition is made to the reset state, the reset signal should only be released after providing a reset input over a period longer than the normal 100  $\mu$ s to reduce the damage to flash memory.

## 17.7.2 Other Notes

### 1. Download Time of On-Chip Program

The programming program that includes the initialization routine and the erasing program that includes the initialization routine are each 3 Kbytes or less. Accordingly, when the CPU clock frequency is 20 MHz, the download for each program takes approximately 10 ms at maximum.

### 2. User Branch Processing Intervals

The intervals for executing the user branch processing differ in programming and erasing. The processing phase also differs. Table 17.10 lists the maximum interval for initiating the user branch processing when the CPU clock frequency is 50 MHz.

**Table 17.10 Initiation Intervals of User Branch Processing**

Processing Name	Maximum Interval
Programming	Approximately 4 ms
Erasing	Approximately 25 ms

However, when operation is done with CPU clock of 50 MHz, maximum value of the time until first user branch processing is as shown in table 17.11.

**Table 17.11 Initial User Branch Processing Time**

Processing Name	Max.
Programming	Approximately 4 ms
Erasing	Approximately 25 ms

### 3. State in which Interrupts are ignored

In the following modes or period, interrupt requests are ignored; they are not executed and the interrupt sources are not retained.

— Boot mode

4. Compatibility with Programming/Erasing Program of Conventional F-ZTAT SH Microcomputer

A programming/erasing program for flash memory used in the conventional F-ZTAT SH microcomputer which does not support download of the on-chip program by a SCO transfer request cannot run in this LSI.

Be sure to download the on-chip program to execute programming/erasing of flash memory in this LSI.

5. Monitoring Runaway by WDT

Unlike the conventional F-ZTAT SH microcomputer, no countermeasures are available for a runaway by WDT during programming/erasing by the downloaded on-chip program.

Prepare countermeasures (e.g. use of the user branch routine and periodic timer interrupts) for WDT while taking the programming/erasing time into consideration as required.

## 17.8 Supplementary Information

### 17.8.1 Specifications of the Standard Serial Communications Interface in Boot Mode

The boot program activated in boot mode communicates with the host via the on-chip SCI of the LSI. The specifications of the serial communications interface between the host and the boot program are described below.

- States of the boot program

The boot program has three states.

1. Bit-rate matching state

In this state, the boot program adjusts the bit rate to match that of the host. When the chip starts up in boot mode, the boot program is activated and enters the bit-rate matching state, in which it receives commands from the host and adjusts the bit rate accordingly. After bit-rate matching is complete, the boot program proceeds to the inquiry-and-selection state.

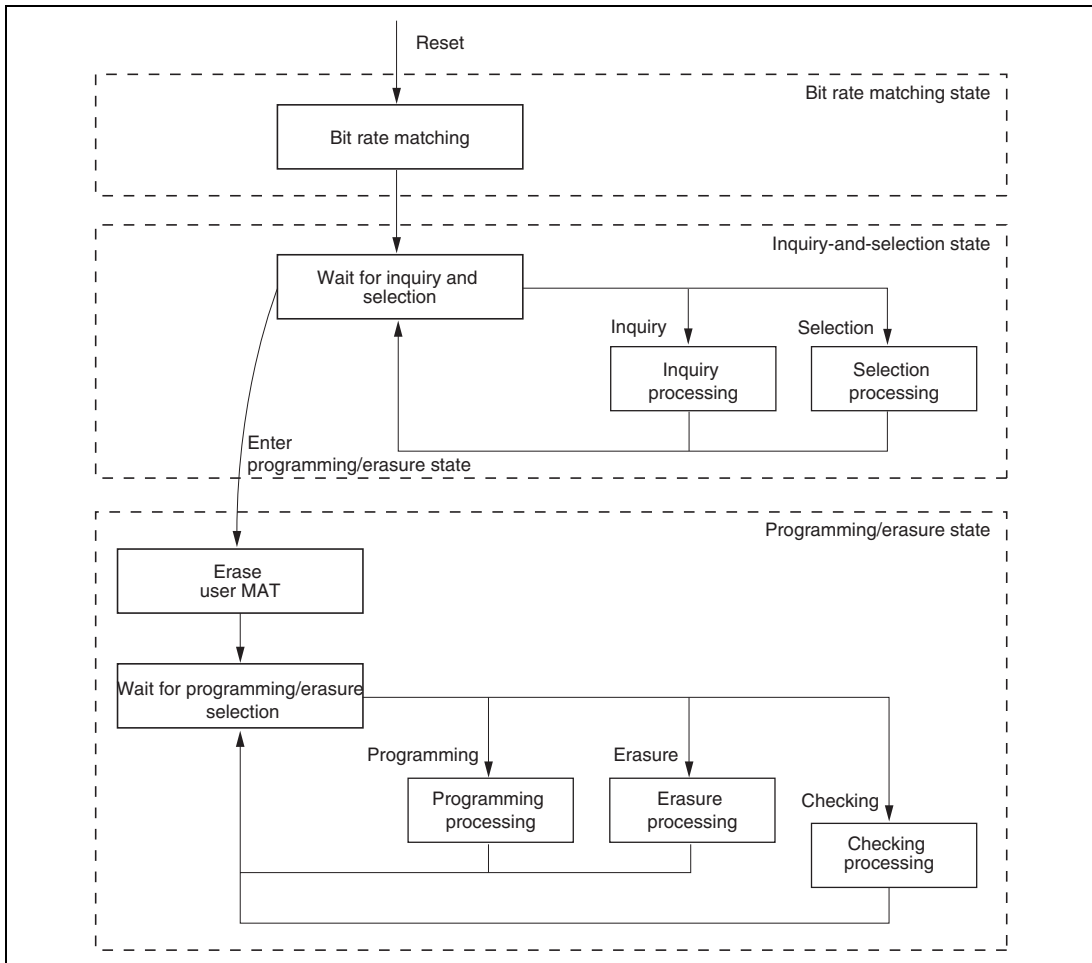
2. Inquiry-and-selection state

In this state, the boot program responds to inquiry commands from the host. The device, clock mode, and bit rate are selected in this state. After making these selections, the boot program enters the programming/erasure state in response to the transition-to-programming/erasure state command. The boot program transfers the erasure program to RAM and executes erasure of the user MAT before it enters the programming/erasure state.

3. Programming/erasure state

In this state, programming/erasure are executed. The boot program transfers the program for programming/erasure to RAM in line with the command received from the host and executes programming/erasure. It also performs sum checking and blank checking as directed by the respective commands.

Figure 17.15 shows the flow of processing by the boot program.

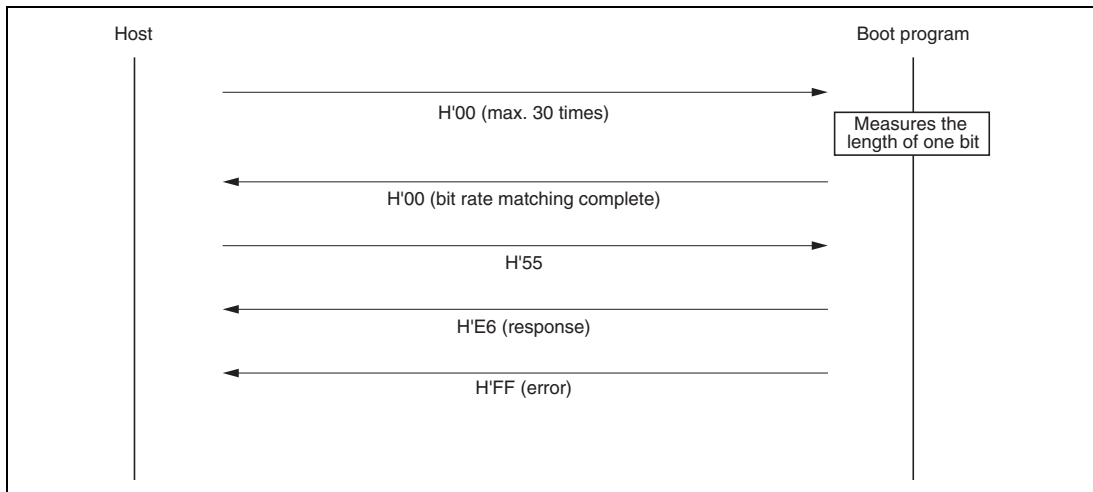


**Figure 17.15 Flow of Processing by the Boot Program**

- **Bit-rate matching state**

In bit-rate matching, the boot program measures the low-level intervals in a signal carrying H'00 data that is transmitted by the host, and calculates the bit rate from this. The bit rate can be changed by the new-bit-rate selection command. On completion of bit-rate matching, the boot program goes to the inquiry and selection state. The sequence of processing in bit-rate matching is shown in figure 17.16.





**Figure 17.16 Sequence of Bit-Rate Matching**

- Communications protocol

Formats in the communications protocol between the host and boot program after completion of the bit-rate matching are as follows.

1. One-character command or one-character response

A command or response consisting of a single character used for an inquiry or the ACK code indicating normal completion.

2. n-character command or n-character response

A command or response that requires n bytes of data, which is used as a selection command or response to an inquiry. The length of programming data is treated separately below.

3. Error response

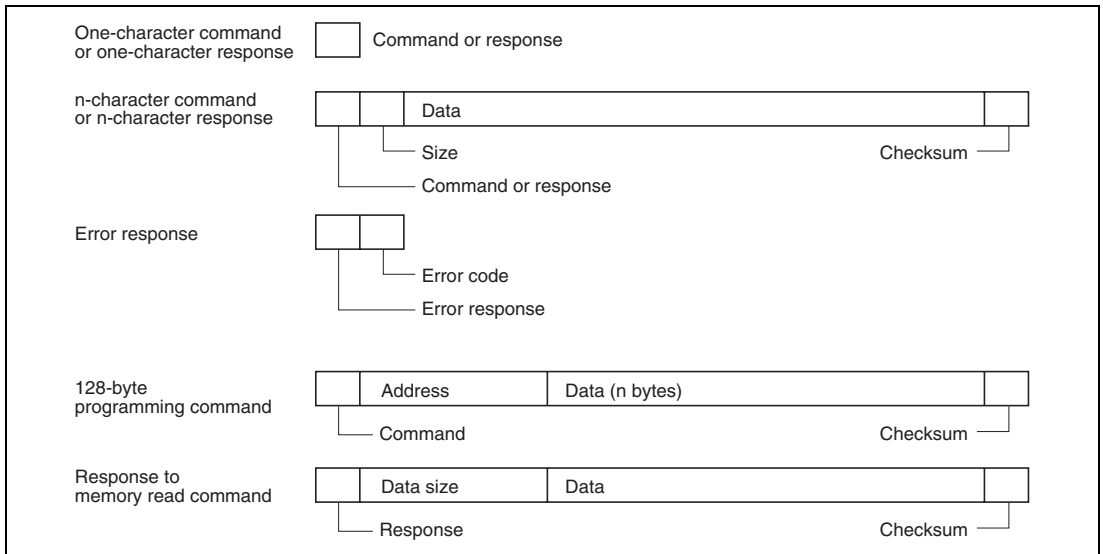
Response to a command in case of an error: two bytes, consisting of the error response and error code.

4. 128-byte programming command

The command itself does not include data-size information. The data length is known from the response to the command for inquiring about the programming size.

5. Response to a memory reading command

This response includes four bytes of size information.



**Figure 17.17 Formats in the Communications Protocol**

- Command (1 byte): Inquiry, selection, programming, erasure, checking, etc.
- Response (1 byte): Response to an inquiry
- Size (one or two bytes): The length of data for transfer, excluding the command/response code, size, and checksum.
- Data (n bytes): Particular data for the command or response
- Checksum (1 byte): Set so that the total sum of byte values from the command code to the checksum and change lower one byte to H'00.
- Error response (1 byte): Error response to a command
- Error code (1 byte): Indicates the type of error.
- Address (4 bytes): Address for programming
- Data (n bytes): Data to be programmed. "n" is known from the response to the command used to inquire about the programming size.
- Data size (4 bytes): Four-byte field included in the response to a memory reading command.

- **Inquiry-and-Selection State**

In this state, the boot program returns information on the flash ROM in response to inquiry commands sent from the host, and selects the device, clock mode, and bit rate in response to the respective selection commands.

The inquiry and selection commands are listed in table 17.12.

**Table 17.12 Inquiry and Selection Commands**

<b>Command</b>	<b>Command Name</b>	<b>Function</b>
H'20	Inquiry on supported devices	Requests the device codes and their respective boot program names.
H'10	Device selection	Selects a device code.
H'21	Inquiry on clock modes	Requests the number of available clock modes and their respective values.
H'11	Clock-mode selection	Selects a clock mode.
H'22	Inquiry on frequency multipliers	Requests the number of clock signals for which frequency multipliers and divisors are selectable, the number of multiplier and divisor settings for the respective clocks, and the values of the multipliers and divisors.
H'23	Inquiry on operating frequency	Requests the minimum and maximum values for operating frequency of the main clock and peripheral clock.
H'25	Inquiry on user MATs	Requests the number of user MAT areas along with their start and end addresses.
H'26	Inquiry on erasure blocks	Requests the number of erasure blocks along with their start and end addresses.
H'27	Inquiry on programming size	Requests the unit of data for programming.
H'3F	New bit rate selection	Selects a new bit rate.
H'40	Transition to programming/erasure state	On receiving this command, the boot program erases the user MAT and enters the programming/erasure state.
H'4F	Inquiry on boot program state	Requests information on the current state of boot processing.

The selection commands should be sent by the host in this order: device selection (H'10), clock-mode selection (H'11), new bit rate selection (H'3F). These commands are mandatory. If the same selection command is sent two or more times, the command that is sent last is effective.

All commands in the above table, except for the boot program state inquiry command (H'4F), are valid until the boot program accepts the transition-to-programming/erasure state command (H'40). That is, until the transition command is accepted, the host can continue to send commands listed in the above table until it has made the necessary inquiries and selections. The host can send the boot program state inquiry command (H'4F) even after acceptance of the transition-to-programming/erasure state command (H'40) by the boot program.

### (1) Inquiry on supported devices

In response to the inquiry on supported devices, the boot program returns the device codes of the devices it supports and the product names of their respective boot programs.

Command 

H'20
------

— Command H'20 (1 byte): Inquiry on supported devices

Response	H'30	Size	No. of devices
	Number of characters	Device code	Product name
	...		
	SUM		

— Response H'30 (1 byte): Response to the inquiry on supported devices

— Size (1 byte): The length of data for transfer excluding the command code, this field (size), and the checksum. Here, it is the total number of bytes taken up by the number of devices, number of characters, device code, and product name fields.

— Number of devices (1 byte): The number of device models supported by the boot program embedded in the microcomputer.

— Number of characters (1 byte): The number of characters in the device code and product name fields.

— Device code (4 bytes): Device code of a supported device (ASCII encoded)

— Product name (n bytes): Product code of the boot program (ASCII encoded)

— SUM (1 byte): Checksum

This is set so that the total sum of all bytes from the command code to the checksum is H'00.

## (2) Device selection

In response to the device selection command, the boot program sets the specified device as the selected device. The boot program will return the information on the selected device in response to subsequent inquiries.

Command	H'10	Size	Device code	SUM
---------	------	------	-------------	-----

- Command H'10 (1 byte): Device selection
- Size (1 byte): Number of characters in the device code (fixed at 4)
- Device code (4 bytes): A device code that was returned in response to an inquiry on supported devices (ASCII encoded)
- SUM (1 byte): Checksum

Response	H'06
----------	------

- Response H'06 (1 byte): Response to device selection  
This is the ACK code and is returned when the specified device code matches one of the supported devices.

Error response	H'90	ERROR
----------------	------	-------

- Error response H'90 (1 byte): Error response to device selection
- ERROR (1 byte): Error code  
H'11: Sum-check error  
H'21: Non-matching device code

## (3) Inquiry on clock modes

In response to the inquiry on clock modes, the boot program returns the number of available clock modes.

Command	H'21
---------	------

- Command H'21 (1 byte): Inquiry on clock modes

Response	H'31	Size	Mode	...	SUM
----------	------	------	------	-----	-----

- Response H'31 (1 byte): Response to the inquiry on clock modes
- Size (1 byte): The total length of the number of modes and mode data fields.
- Mode (1 byte): Selectable clock mode (example: H'01 denotes clock mode 1)
- SUM (1 byte): Checksum

#### (4) Clock-mode selection

In response to the clock-mode selection command, the boot program sets the specified clock mode. The boot program will return the information on the selected clock mode in response to subsequent inquiries.

Command	H'11	Size	Mode	SUM
---------	------	------	------	-----

- Command H'11 (1 byte): Clock mode selection
- Size (1 byte): Number of characters in the clock-mode field (fixed at 1)
- Mode (1 byte): A clock mode returned in response to the inquiry on clock modes
- SUM (1 byte): Checksum

Response	H'06
----------	------

- Response H'06 (1 byte): Response to clock mode selection  
This is the ACK code and is returned when the specified clock-mode matches one of the available clock modes.

Error response	H'91	ERROR
----------------	------	-------

- Error response H'91 (1 byte): Error response to clock mode selection
- ERROR (1 byte): Error code  
H'11: Sum-check error  
H'22: Non-matching clock mode

**(5) Inquiry on frequency multipliers**

In response to the inquiry on frequency multipliers, the boot program returns information on the settable frequency multipliers or divisors.

Command 

H'22
------

— Command H'22 (1 byte): Inquiry on frequency multipliers

Response	H'32	Size	No. of frequency types					
	No. of multipliers	Multiplier	...					
	...							
	SUM							

— Response H'32 (1 byte): Response to the inquiry on frequency multipliers

— Size (1 byte): The total length of the number of frequency types, number of multipliers, and multiplier fields.

— Number of frequency types (1 byte): The number of operating clocks for which multipliers can be selected

(for example, if frequency multiplier settings can be made for the frequencies of the main and peripheral operating clocks, the value should be H'02).

— Number of multipliers (1 byte): The number of multipliers selectable for the operating frequency of the main or peripheral modules

— Multiplier (1 byte):

Multiplier: Numerical value in the case of frequency multiplication (e.g. H'04 for  $\times 4$ )

Divisor: Two's complement negative numerical value in the case of frequency division (e.g. H'FE [-2] for  $\times 1/2$ )

As many multiplier fields are included as there are multipliers or divisors, and combinations of the number of frequency types are repeated as many times as there are operating clocks.

— SUM (1 byte): Checksum

**(6) Inquiry on operating frequency**

In response to the inquiry on operating frequency, the boot program returns the number of operating frequencies and the maximum and minimum values.

Command 

H'23
------

— Command H'23 (1 byte): Inquiry on operating frequency

Response	H'33	Size	No. of frequency types
	Operating freq. (min)		Operating freq. (max)
	...		
	SUM		

— Response H'33 (1 byte): Response to the inquiry on operating frequency

— Size (1 byte): The total length of the number of frequency types, and maximum and minimum values of operating frequency fields.

— Number of frequency types (1 byte): The number of operating clock frequencies required within the device.

For example, the value two indicates main and peripheral operating clock frequencies.

— Minimum value of operating frequency (2 bytes): The minimum frequency of a frequency-multiplied or -divided clock signal.

The value in this field and in the maximum value field is the frequency in MHz to two decimal places, multiplied by 100 (for example, if the frequency is 20.00 MHz, the value multiplied by 100 is 2000, so H'07D0 is returned here).

— Maximum value of operating frequency (2 bytes): The maximum frequency of a frequency-multiplied or -divided clock signal.

As many pairs of minimum values are included as there are frequency types.

— SUM (1 byte): Checksum



**(7) Inquiry on user MATs**

In response to the inquiry on user MATs, the boot program returns the number of user MAT areas and their addresses.

Command 

H'25
------

— Command H'25 (1 byte): Inquiry on user MAT information

Response	H'35	Size	No. of areas		
	First address of the area			Last address of the area	
	...				
	SUM				

— Response H'35 (1 byte): Response to the inquiry on user MATs

— Size (1 byte): The total length of the number of areas and first and last address fields.

— Number of areas (1 byte): The number of user MAT areas.

H'01 is returned if the entire user MAT area is continuous.

— First address of the area (4 bytes)

— Last address of the area (4 bytes)

As many pairs of first and last address field are included as there are areas.

— SUM (1 byte): Checksum

**(8) Inquiry on erasure blocks**

In response to the inquiry on erasure blocks, the boot program returns the number of erasure blocks in the user MAT and the addresses where each block starts and ends.

Command 

H'26
------

— Command H'26 (1 byte): Inquiry on erasure blocks

Response	H'36	Size	No. of blocks		
	First address of the block			Last address of the block	
	...				
	SUM				

- Response H'36 (1 byte): Response to the inquiry on erasure blocks
- Size (2 bytes): The total length of the number of blocks and first and last address fields.
- Number of blocks (1 byte): The number of erasure blocks in flash memory
- First address of the block (4 bytes)
- Last address of the block (4 bytes)  
As many pairs of first and last address data are included as there are blocks.
- SUM (1 byte): Checksum

### (9) Inquiry on programming size

In response to the inquiry on programming size, the boot program returns the size, in bytes, of the unit for programming.

Command 

H'27
------

- Command H'27 (1 byte): Inquiry on programming size

Response 

H'37	Size	Programming size	SUM
------	------	------------------	-----

- Response H'37 (1 byte): Response to the inquiry on programming size
- Size (1 byte): The number of characters in the programming size field (fixed at 2)
- Programming size (2 bytes): The size of the unit for programming  
This is the unit for the reception of data to be programmed.
- SUM (1 byte): Checksum

### (10) New bit rate selection

In response to the new-bit-rate selection command, the boot program changes the bit rate setting to the new bit rate and, if the setting was successful, responds to the ACK sent by the host by returning another ACK at the new bit rate.

The new-bit-rate selection command should be sent after clock-mode selection.

Command 

H'3F	Size	Bit rate	Input frequency
No. of multipliers	Multiplier 1	Multiplier 2	
SUM			

- Command H'3F (1 byte): New bit rate selection
- Size (1 byte): The total length of the bit rate, input frequency, number of multipliers, and multiplier fields
- Bit rate (2 bytes): New bit rate  
The bit rate value divided by 100 should be set here (for example, to select 19200 bps, the set H'00C0, which is 192 in decimal notation).
- Input frequency (2 bytes): The frequency of the clock signal fed to the boot program  
This should be the frequency in MHz to the second decimal place, multiplied by 100 (for example, if the frequency is 28.882 MHz, the values is truncated to the second decimal place and multiplied by 100, making 2888; so H'0B48 should be set in this field).
- Number of multipliers (1 byte): The number of selectable frequency multipliers and divisors for the device.  
This is normally 2, which indicates the main operating frequency and the operating frequency of the peripheral modules.
- Multiplier 1 (1 byte): Multiplier or divisor for the main operating frequency  
Multiplier: Numerical value of the frequency multiplier (e.g. H'04 for  $\times 4$ )  
Divisor: Two's complement negative numerical value in the case of frequency division (e.g. H'FE [-2] for  $\times 1/2$ )
- Multiplier 2 (1 byte): Multiplier or divisor for the peripheral operating frequency  
Multiplier: Numerical value of the frequency multiplier (e.g. H'04 for  $\times 4$ )  
Divisor: Two's complement negative numerical value in the case of frequency division (e.g. H'FE [-2] for  $\times 1/2$ )
- SUM (1 byte): Checksum

Response

H'06
------

- Response H'06 (1 byte): Response to the new-bit-rate selection command  
This is the ACK code and is returned if the specified bit rate has been selected.

Error

response

H'BF
------

ERROR
-------

- Error response H'BF (1 byte): Error response to new bit rate selection
- ERROR (1 byte): Error code  
H'11: Sum-check error  
H'24: Bit rate selection error (the specified bit rate is not selectable).  
H'25: Input frequency error (the specified input frequency is not within the range from the minimum to the maximum value).

H'26: Frequency multiplier error (the specified multiplier does not match an available one).

H'27: Operating frequency error (the specified operating frequency is not within the range from the minimum to the maximum value).

The received data are checked in the following ways.

#### 1. Input frequency

The value of the received input frequency is checked to see if it is within the range of the minimum and maximum values of input frequency for the selected clock mode of the selected device. A value outside the range generates an input frequency error.

#### 2. Multiplier

The value of the received multiplier is checked to see if it matches a multiplier or divisor that is available for the selected clock mode of the selected device. A value that does not match an available ratio generates a frequency multiplier error.

#### 3. Operating frequency

The operating frequency is calculated from the received input frequency and the frequency multiplier or divisor. The input frequency is the frequency of the clock signal supplied to the LSI, while the operating frequency is the frequency at which the LSI is actually driven. The following formulae are used for this calculation.

Operating frequency = input frequency  $\times$  multiplier, or

Operating frequency = input frequency / divisor

The calculated operating frequency is checked to see if it is within the range of the minimum and maximum values of the operating frequency for the selected clock mode of the selected device. A value outside the range generates an operating frequency error.

#### 4. Bit rate

From the peripheral operating frequency ( $P\phi$ ) and the bit rate ( $B$ ), the value ( $= n$ ) of the clock select bits (CKS) in the serial mode register (SCSMR) and the value ( $= N$ ) of the bit rate register (SCBRR) are calculated, after which the error in the bit rate is calculated. This error is checked to see if it is smaller than 4%. A result greater than or equal to 4% generates a bit rate selection error. The following formula is used to calculate the error.

$$\text{Error (\%)} = \left\{ \left[ \frac{P\phi \times 10^6}{(N + 1) \times B \times 64 \times 2^{2n-1}} \right] - 1 \right\} \times 100$$

When the new bit rate is selectable, the boot program returns an ACK code to the host and then makes the register setting to select the new bit rate. The host then sends an ACK code at the new bit rate, and the boot program responds to this with another ACK code, this time at the new bit rate.

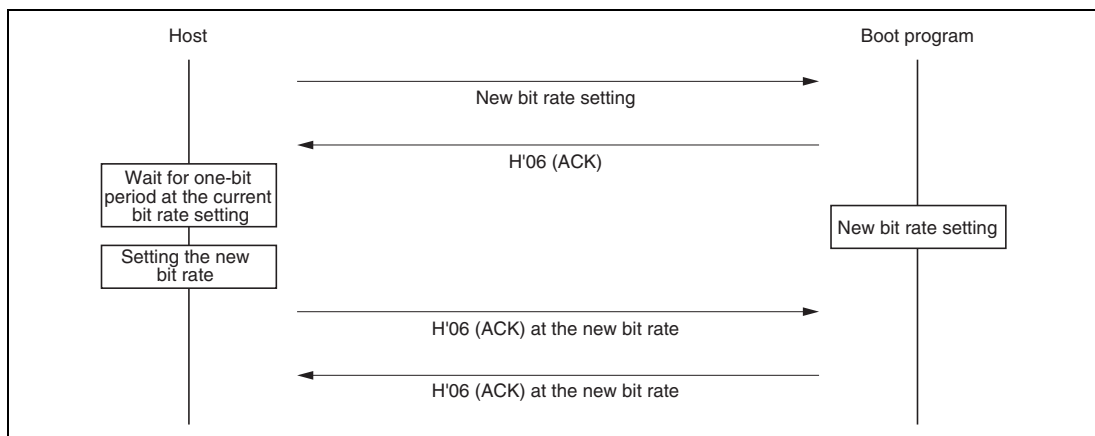
Acknowledge H'06

— Acknowledge H'06 (1 byte): The ACK code sent by the host to acknowledge the new bit rate.

Response H'06

— Response H'06 (1 byte): The ACK code transferred in response to acknowledgement of the new bit rate

The sequence of new bit rate selection is shown in figure 17.18.



**Figure 17.18 Sequence of New Bit Rate Selection**

## (11) Transition to the programming/erasure state

In response to the transition to the programming/erasure state command, the boot program transfers the erasing program and runs it to erase any data in the user MAT. On completion of this erasure, the boot program returns the ACK code and enters the programming/erasure state.

Before sending the programming selection command and data for programming, the host must select the device, clock mode, and new bit rate for the LSI by issuing the device selection command, clock-mode selection command, new-bit-rate selection command, and then initiate the transition to the programming/erasure state by sending the corresponding command to the boot program.

Command 

H'40
------

— Command H'40 (1 byte): Transition to programming/erasure state

Response 

H'06
------

— Response H'06 (1 byte): Response to the transition-to-programming/erasure state command  
This is returned as ACK when erasure of the user MAT has succeeded after transfer of the erasure program.

Error response 

H'C0	H'51
------	------

— Error response H'C0 (1 byte): Error response to the transition-to-programming/erasure state command

— ERROR (1 byte): Error code

H'51: Erasure error (Erasure did not succeed because of an error.)

- Command Error

Command errors are generated by undefined commands, commands sent in an incorrect order, and the inability to accept a command. For example, sending the clock-mode selection command before device selection or an inquiry command after the transition-to-programming/erasure state command generates a command error.

Error  
response

H'80	H'xx
------	------

- Error response H'80 (1 byte): Command error
- Command H'xx (1 byte): Received command

- Order of Commands

In the inquiry-and-selection state, commands should be sent in the following order.

1. Send the inquiry on supported devices command (H'20) to get the list of supported devices.
2. Select a device from the returned device information, and send the device selection command (H'10) to select that device.
3. Send the inquiry on clock mode command (H'21) to get the available clock modes.
4. Select a clock mode from among the returned clock modes, and send the clock-mode selection command (H'11).
5. After selection of the device and clock mode, send the commands to inquire about frequency multipliers (H'22) and operating frequencies (H'23) to get the information required to select a new bit rate.
6. Taking into account the returned information on the frequency multipliers and operating frequencies, send a new-bit-rate selection command (H'3F).
7. After the device and clock mode have been selected, get the information required for programming and erasure of the user MAT by sending the commands to inquire about the user MAT (H'25), erasure block (H'26), and programming size (H'27).
8. After making all necessary inquiries and the new bit rate selection, send the transition-to-programming/erasure state command (H'40) to place the boot program in the programming/erasure state.

- **Programming/Erase State**

In this state, the boot program must select the form of programming corresponding to the programming-selection command and then write data in response to 128-byte programming commands, or perform erasure in block units in response to the erasure-selection and block-erasure commands.

The programming and erasure commands are listed in table 17.13.

**Table 17.13 Programming and Erasure Commands**

<b>Command</b>	<b>Command Name</b>	<b>Function</b>
H'43	Selection of user MAT programming	Selects transfer of the program for user MAT programming.
H'50	128-byte programming	Executes 128-byte programming.
H'48	Erase selection	Selects transfer of the erasure program.
H'58	Block erasure	Executes erasure of the specified block.
H'52	Memory read	Reads from memory.
H'4B	Sum checking of user MAT	Executes sum checking of the user MAT.
H'4D	Blank checking of user MAT	Executes blank checking of the user MAT.
H'4F	Inquiry on boot program state	Requests information on the state of boot processing.

- **Programming**

Programming is performed by issuing a programming-selection command and the 128-byte programming command.

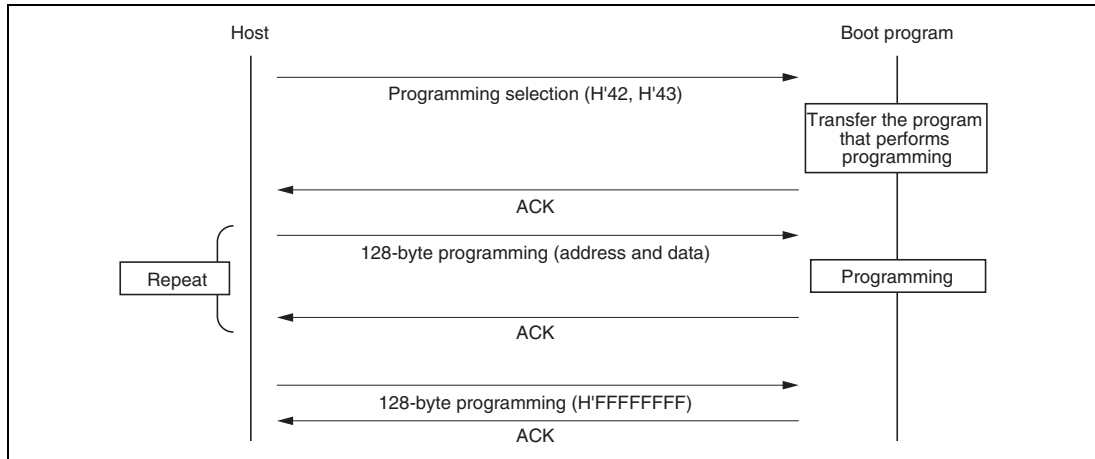
Firstly, the host issues the programming-selection command to select the MAT to be programmed and programming by the method.

Next, the host issues a 128-byte programming command. 128 bytes of data for programming by the method selected by the preceding programming selection command are expected to follow the command. To program more than 128 bytes, repeatedly issue 128-byte programming commands. To terminate programming, the host should send another 128-byte programming command with the address H'FFFFFFFF. On completion of programming, the boot program waits for the next programming/erasure selection command.

To then program the other MAT, start by sending the programming select command.



The sequence of programming by programming-selection and 128-byte programming commands is shown in figure 17.19.



**Figure 17.19 Sequence of Programming**

### (1) Selection of user MAT programming

In response to the command for selecting programming of the user MAT, the boot program transfers the corresponding flash-writing program, i.e. the program for writing to the user MAT.

Command 

H'43
------

— Command H'43 (1 byte): Selects programming of the user MAT.

Response 

H'06
------

— Response H'06 (1 byte): Response to selection of user MAT programming  
This ACK code is returned after transfer of the program that performs writing to the user MAT.

Error response 

H'C3	ERROR
------	-------

— Error response H'C3 (1 byte): Error response to selection of user MAT programming

- ERROR (1 byte): Error code  
H'54: Error in selection processing (processing was not completed because of a transfer error)

## (2) 128-byte programming

In response to the 128-byte programming command, the boot program executes the flash-writing program transferred in response to the command to program into the user MAT.

Command	H'50	Address for programming						
	Data	...						
	...							
	SUM							

- Command H'50 (1 byte): 128-byte programming
- Address for programming (4 bytes): Address where programming starts  
Specify an address on a 128-byte boundary.  
[Example] H'00, H01, H'00, H'00: H'00010000
- Programming data (n bytes): Data for programming  
The length of the programming data is the size returned in response to the programming size inquiry command.
- SUM (1 byte): Checksum

Response	H'06
----------	------

- Response H'06 (1 byte): Response to 128-byte programming  
The ACK code is returned on completion of the requested programming.

Error response	H'D0	ERROR
----------------	------	-------

- Error response H'D0 (1 byte): Error response to 128-byte programming
- ERROR (1 byte): Error code  
H'11: Sum-check error  
H'2A: Address error (the address is not within the range for the selected MAT)  
H'53: Programming error (programming failed because of an error in programming)

The specified address should be on a boundary corresponding to the unit of programming (programming size). For example, when programming 128 bytes of data, the lowest byte of the address should be either H'00 or H'80. When less than 128 bytes of data are to be programmed, the host should transmit the data after padding the vacant bytes with H'FF.

To terminate programming of a given MAT, send a 128-byte programming command with the address field H'FFFFFFF. This informs the boot program that all data for the selected MAT have been sent; the boot program then waits for the next programming/erasure selection command.

Command	H'50	Address for programming	SUM
---------	------	-------------------------	-----

- Command H'50 (1 byte): 128-byte programming
- Address for programming (4 bytes): Terminating code (H'FF, H'FF, H'FF, H'FF)
- SUM (1 byte): Checksum

Response	H'06
----------	------

- Response H'06 (1 byte): Response to 128-byte programming  
This ACK code is returned on completion of the requested programming.

Error response	H'D0	ERROR
----------------	------	-------

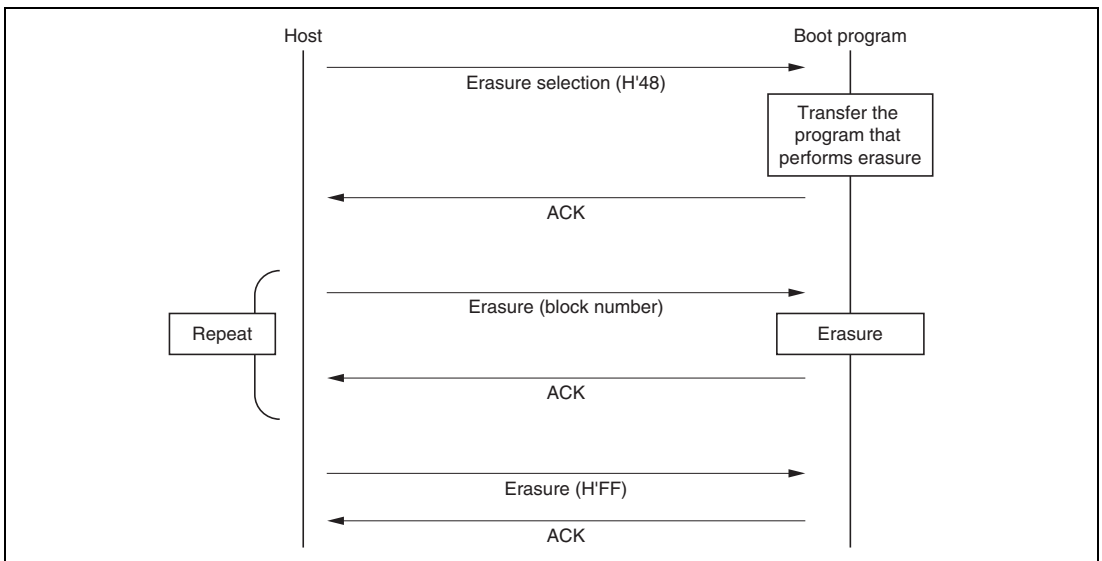
- Error response H'D0 (1 byte): Error response to 128-byte programming
- ERROR (1 byte): Error code  
H'11: Sum-check error  
H'53: Programming error

- Erasure

Erasure is performed by issuing the erasure selection command and then one or more block erasure commands.

Firstly, the host sends the erasure selection command to select erasure; after that, it sends a block erasure command to actually erase a specific block. To erase multiple blocks, send further block erasure commands. To terminate erasure, the host should send a block erasure command with the block number H'FF. After this, the boot program waits for the next programming/erasure selection command.

The sequence of erasure by the erasure selection command and block erasure command is shown in figure 17.20.



**Figure 17.20 Sequence of Erasure**

**(1) Select erasure**

In response to the erasure selection command, the boot program transfers the program that performs erasure, i.e. erases data in the user MAT.

Command 

H'48
------

— Command H'48 (1 byte): Selects erasure.

Response 

H'06
------

— Response H'06 (1 byte): Response to selection of erasure  
This ACK code is returned after transfer of the program that performs erasure.

Error response 

H'C8	ERROR
------	-------

— Error response H'C8 (1 byte): Error response to selection of erasure  
— ERROR (1 byte): Error code  
H'54: Error in selection processing (processing was not completed because of a transfer error.)

**(2) Block erasure**

In response to the block erasure command, the boot program erases the data in a specified block of the user MAT.

Command 

H'58	Size	Block number	SUM
------	------	--------------	-----

— Command H'58 (1 byte): Erasure of a block  
— Size (1 byte): The number of characters in the block number field (fixed at 1)  
— Block number (1 byte): Block number of the block to be erased  
— SUM (1 byte): Checksum

Response 

H'06
------

— Response H'06 (1 byte): Response to the block erasure command  
This ACK code is returned when the block has been erased.

Error  
response

H'D8	ERROR
------	-------

- Error response H'D8 (1 byte): Error response to the block erasure command
- ERROR (1 byte): Error code
  - H'11: Sum-check error
  - H'29: Block number error (the specified block number is incorrect.)
  - H'51: Erasure error (an error occurred during erasure.)

On receiving the command with H'FF as the block number, the boot program stops erasure processing and waits for the next programming/erasure selection command.

Command

H'58	Size	Block number	SUM
------	------	--------------	-----

- Command H'58 (1 byte): Erasure of a block
- Size (1 byte): The number of characters in the block number field (fixed at 1)
- Block number (1 byte): H'FF (erasure terminating code)
- SUM (1 byte): Checksum

Response

H'06
------

- Response H'06 (1 byte): ACK code to indicate response to the request for termination of erasure

To perform erasure again after having issued the command with the block number specified as H'FF, execute the process from the selection of erasure.

- Memory read

In response to the memory read command, the boot program returns the data from the specified address.

Command

H'52	Size	Area	First address for reading
Amount to read			SUM

- Command H'52 (1 byte): Memory read
- Size (1 byte): The total length of the area, address for reading, and amount to read fields (fixed value of 9)

- Area (1 byte):  
H'01: User MAT  
An incorrect area specification will produce an address error.
- Address where reading starts (4 bytes)
- Amount to read (4 bytes): The amount of data to be read
- SUM (1 byte): Checksum

Response	H'52	Amount to read						
	Data	...						
	SUM							

- Response H'52 (1 byte): Response to the memory read command
- Amount to read (4 bytes): The amount to read as specified in the memory read command
- Data (n bytes): The specified amount of data read out from the specified address
- SUM (1 byte): Checksum

Error response	H'D2	ERROR
----------------	------	-------

- Error response H'D2 (1 byte): Error response to memory read command
- ERROR (1 byte): Error code  
H'11: Sum-check error  
H'2A: Address error (the address specified for reading is beyond the range of the MAT)  
H'2B: Size error (the specified amount is greater than the size of the MAT, the last address for reading as calculated from the specified address for the start of reading and the amount to read is beyond the MAT area, or "0" was specified as the amount to read)

- Sum checking of the user MAT

In response to the command for sum checking of the user MAT, the boot program adds all bytes of data in the user MAT and returns the result.

Command 

H'4B
------

— Command H'4B (1 byte): Sum checking of the user MAT

Response 

H'5B	Size	Checksum for the MAT	SUM
------	------	----------------------	-----

— Response H'5B (1 byte): Response to sum checking of the user MAT

— Size (1 byte): The number of characters in the checksum for the MAT (fixed to 4)

— Checksum for the MAT (4 bytes): Result of checksum calculation for the user MAT: the total of all data in the MAT, in byte units.

— SUM (1 byte): Checksum (for the transmitted data)

- Blank checking of the user MAT

In response to the command for blank checking of the user MAT, the boot program checks to see if the whole of the user MAT is blank; the value returned indicates the result.

Command 

H'4D
------

— Command H'4D (1 byte): Blank checking of the user MAT

Response 

H'06
------

— Response H'06 (1 byte): Response to blank checking of the user MAT

The ACK code is returned when the whole area is blank (all bytes are H'FF).

Error response 

H'CD	H'52
------	------

— Error response H'CD (1 byte): Error response to blank checking of the user MAT

— Error code H'52 (1 byte): Non-erased error



- Inquiry on boot program state

In response to the command for inquiry on the state of the boot program, the boot program returns an indicator of its current state and error information. This inquiry can be made in the inquiry-and-selection state or the programming/erasure state.

Command 

H'4F
------

— Command H'4F (1 byte): Inquiry on boot program state

Response 

H'5F	Size	STATUS	ERROR	SUM
------	------	--------	-------	-----

— Response H'5F (1 byte): Response to the inquiry regarding boot-program state

— Size (1 byte): The number of characters in STATUS and ERROR (fixed at 2)

— STATUS (1 byte): State of the standard boot program

See table 17.14, Status Codes.

— ERROR (1 byte): Error state (indicates whether the program is in normal operation or an error has occurred)

ERROR = 0: Normal

ERROR ≠ 0: Error

See table 17.15, Error Codes.

— SUM (1 byte): Checksum

**Table 17.14 Status Codes**

Code	Description
H'11	Waiting for device selection
H'12	Waiting for clock-mode selection
H'13	Waiting for bit-rate selection
H'1F	Waiting for transition to programming/erasure status (bit-rate selection complete)
H'31	Erasing the user MAT
H'3F	Waiting for programming/erasure selection (erasure complete)
H'4F	Waiting to receive data for programming (programming complete)
H'5F	Waiting for erasure block specification (erasure complete)

**Table 17.15 Error Codes**

<b>Code</b>	<b>Description</b>
H'00	No error
H'11	Sum check error
H'21	Non-matching device code error
H'22	Non-matching clock mode error
H'24	Bit-rate selection failure
H'25	Input frequency error
H'26	Frequency multiplier error
H'27	Operating frequency error
H'29	Block number error
H'2A	Address error
H'2B	Data length error (size error)
H'51	Erase error
H'52	Non-erased error
H'53	Programming error
H'54	Selection processing error
H'80	Command error
H'FF	Bit-rate matching acknowledge error

### 17.8.2 Areas for Storage of the Procedural Program and Data for Programming

In the descriptions in the previous section, storable areas for the programming/erasing procedure programs and program data are assumed to be in on-chip RAM. However, the procedure programs and data can be executed in other areas as long as the following conditions are satisfied.

1. The on-chip programming/erasing program is downloaded from the address set by FTDAR in on-chip RAM, therefore, this area is not available for use.
2. The on-chip programming/erasing program will use 128 bytes or more as a stack. Make sure this area is reserved.
3. Since download by setting the SCO bit to 1 will cause the MATs to be switched, it should be executed in on-chip RAM.
4. The flash memory is accessible until the start of programming or erasing, that is, until the result of downloading has been decided. When in a mode in which the external address space is not accessible, such as single-chip mode, the required procedure programs, interrupt vector

table, interrupt processing routine, and user branch program should be transferred to on-chip RAM before programming/erasing of the flash memory starts.

5. The flash memory is not accessible during programming/erasing operations. Therefore, the programming/erasing program must be downloaded to on-chip RAM in advance. Areas for executing each procedure program for initiating programming/erasing, the user program at the user branch destination for programming/erasing, the interrupt vector table, and the interrupt processing routine must be located in on-chip RAM.
6. After programming/erasing, access to flash memory is inhibited until FKEY is cleared. A reset state ( $\overline{\text{RES}} = 0$ ) for more than at least 100  $\mu\text{s}$  must be taken when the LSI mode is changed to reset on completion of a programming/erasing operation. Transitions to the reset state during programming/erasing are inhibited. When the reset signal is accidentally input to the LSI, a longer period in the reset state than usual (100  $\mu\text{s}$ ) is needed before the reset signal is released.
7. When the program data storage area indicated by the FMPDR parameter in the programming processing is within the flash memory area, an error will occur. Therefore, temporarily transfer the program data to on-chip RAM to change the address set in FMPDR to an address other than flash memory.

Tables 17.16 and 17.17 show the areas in which the program data can be stored and executed according to the operation type and mode.

**Table 17.16 Executable MAT**

Operation	Initiated Mode
	User Program Mode
Programming	Table 17.17 (1)
Erasing	Table 17.17 (2)

**Table 17.17 (1) Usable Area for Programming in User Program Mode**

Item	Storable/Executable Area		Selected MAT	
	On-Chip RAM	User MAT	User MAT	Embedded Program Storage MAT
Program data storage area	√	X*	—	—
Selecting on-chip program to be downloaded	√	√	√	
Writing H'A5 to key register	√	√	√	
Writing 1 to SCO in FCCS (download)	√	X		√
Key register clearing	√	√	√	
Deciding download result	√	√	√	
Download error processing	√	√	√	
Setting initialization parameters	√	√	√	
Initialization	√	X	√	
Deciding initialization result	√	√	√	
Initialization error processing	√	√	√	
Interrupt processing routine	√	X	√	
Writing H'5A to key register	√	√	√	
Setting programming parameters	√	X	√	
Programming	√	X	√	
Deciding programming result	√	X	√	
Programming error processing	√	X	√	
Key register clearing	√	X	√	

Pro-gram-ming pro-ce-dure

Note: \* If the data has been transferred to on-chip RAM in advance, this area can be used.

Table 17.17 (2) Usable Area for Erasure in User Program Mode

Item	Storable/Executable Area		Selected MAT	
	On-Chip RAM	User MAT	User MAT	Embedded Program Storage MAT
Selecting on-chip program to be downloaded	√	√	√	
Writing H'A5 to key register	√	√	√	
Writing 1 to SCO in FCCS (download)	√	X		√
Key register clearing	√	√	√	
Deciding download result	√	√	√	
Download error processing	√	√	√	
Setting initialization parameters	√	√	√	
Initialization	√	X	√	
Deciding initialization result	√	√	√	
Initialization error processing	√	√	√	
Interrupt processing routine	√	X	√	
Writing H'5A to key register	√	√	√	
Setting erasure parameters	√	X	√	
Erasure	√	X	√	
Deciding erasure result	√	X	√	
Erasing error processing	√	X	√	
Key register clearing	√	X	√	

Erasing procedure

## 17.9 Off-Board Programming Mode

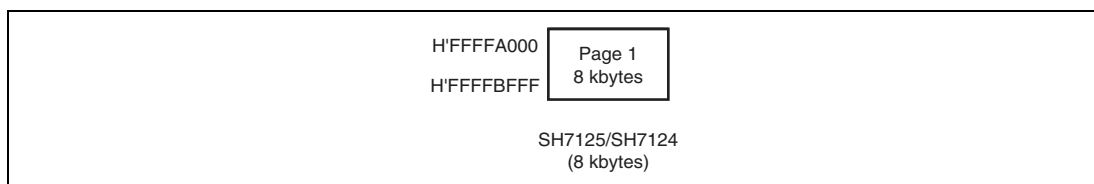
A PROM programmer can be used to perform programming/erasing via a socket adapter, just as for a discrete flash memory. Use a PROM programmer that supports the Renesas 128-Kbyte flash memory on-chip MCU device type (F-ZTAT128DV5).

## Section 18 RAM

This LSI has an on-chip high-speed static RAM. The on-chip RAM is connected to the CPU by a 32-bit data bus (L bus), enabling 8, 16, or 32-bit width access to data in the on-chip RAM.

The on-chip RAM is allocated to different addresses according to each product as shown in figure 18.1. The on-chip RAM can be accessed from the CPU (via the L bus). An access from the L bus (CPU) is a 1-cycle access. In addition, the contents of the on-chip RAM are retained in sleep mode or software standby mode, and at a power-on reset or manual reset.

The on-chip RAM can be enabled or disabled by means of the RAME bit in the RAM control register (RAMCR). For details on the RAM control register (RAMCR), refer to section 19.3.7, RAM Control Register (RAMCR).



**Figure 18.1 On-chip RAM Addresses**

## **18.1 Usage Notes**

### **18.1.1 Module Standby Mode Setting**

RAM can be enabled/disabled by the standby control register. The initial value enables RAM operation. RAM access is disabled by setting the module standby mode. For details, see section 19, Power-Down Modes.

### **18.1.2 Address Error**

When an address error in write access to the on-chip RAM occurs, the contents of the on-chip RAM may be corrupted.

### **18.1.3 Initial Values in RAM**

After power has been supplied, initial values in RAM remain undefined until RAM is written.



## Section 19 Power-Down Modes

This LSI supports the following power-down modes: sleep mode, software standby mode, and module standby mode.

### 19.1 Features

- Supports sleep mode, software standby mode, and module standby mode.

#### 19.1.1 Types of Power-Down Modes

This LSI has the following power-down modes.

- Sleep mode
- Software standby mode
- Module standby mode

Table 19.1 shows the methods to make a transition from the program execution state, as well as the CPU and peripheral module states in each mode and the procedures for canceling each mode.

**Table 19.1 States of Power-Down Modes**

Mode	Transition Method	State					On-Chip Peripheral Modules	Canceling Procedure
		CPG	CPU	CPU Register	On-Chip Memory			
Sleep	Execute SLEEP instruction with STBY bit in STBCR1 cleared to 0.	Runs	Halts	Held		Runs	Run	<ul style="list-style-type: none"> <li>Reset</li> </ul>
Software standby	Execute SLEEP instruction with STBY bit in STBCR1 and STBYMD bit in STBCR6 set to 1.	Halts	Halts	Held		Halts (contents retained)	Halt	<ul style="list-style-type: none"> <li>Interrupt by NMI or IRQ</li> <li>Power-on reset by the <math>\overline{\text{RES}}</math> pin</li> </ul>
Module standby	Set MSTP bits in STBCR2 to STBCR5 to 1.	Runs	Runs	Held		Specified module halts (contents retained)	Specified module halts	<ul style="list-style-type: none"> <li>Clear MSTP bit to 0</li> <li>Power-on reset (for modules whose MSTP bit has an initial value of 0)</li> </ul>

Note: For details on the states of on-chip peripheral module registers in each mode, refer to section 20.3, Register States in Each Operating Mode. For details on the pin states in each mode, refer to appendix A, Pin States.

## 19.2 Input/Output Pins

Table 19.2 lists the pins used for the power-down modes.

**Table 19.2 Pin Configuration**

Pin Name	Abbr.	I/O	Description
Power-on reset	$\overline{\text{RES}}$	Input	Power-on reset input signal. Power-on reset by low level.
Manual reset	$\overline{\text{MRES}}$	Input	Manual reset input signal. Manual reset by low level.

## 19.3 Register Descriptions

There are following registers used for the power-down modes. For details on the addresses of these registers and the states of these registers in each processing state, see section 20, List of Registers.

**Table 19.3 Register Configuration**

Register Name	Abbreviation	R/W	Initial Value	Address	Access Size
Standby control register 1	STBCR1	R/W	H'00	H'FFFFE802	8
Standby control register 2	STBCR2	R/W	H'38	H'FFFFE804	8
Standby control register 3	STBCR3	R/W	H'FF	H'FFFFE806	8
Standby control register 4	STBCR4	R/W	H'FF	H'FFFFE808	8
Standby control register 5	STBCR5	R/W	H'03	H'FFFFE80A	8
Standby control register 6	STBCR6	R/W	H'00	H'FFFFE80C	8
RAM control register	RAMCR	R/W	H'10	H'FFFFE880	8

### 19.3.1 Standby Control Register 1 (STBCR1)

STBCR1 is an 8-bit readable/writable register that specifies the state of the power-down mode.

Bit:	7	6	5	4	3	2	1	0
	STBY	-	-	-	-	-	-	-
Initial value:	0	0	0	0	0	0	0	0
R/W:	R/W	R	R	R	R	R	R	R

Bit	Bit Name	Initial Value	R/W	Description
7	STBY	0	R/W	Standby Specifies transition to software standby mode. 0: Executing SLEEP instruction makes this LSI sleep mode 1: Executing SLEEP instruction makes this LSI software standby mode
6 to 0	—	All 0	R	Reserved These bits are always read as 0. The write value should always be 0.

### 19.3.2 Standby Control Register 2 (STBCR2)

STBCR2 is an 8-bit readable/writable register that controls the RAM operation in power-down mode.

Bit:	7	6	5	4	3	2	1	0
	MSTP 7	-	-	-	-	-	-	-
Initial value:	0	0	1	1	1	0	0	0
R/W:	R/W	R/W	R/W	R/W	R/W	R	R	R

Bit	Bit Name	Initial Value	R/W	Description
7	MSTP7	0	R/W	Module Stop Bit 7  When this bit is set to 1, the supply of the clock to the RAM is halted.  0: RAM operates 1: Clock supply to RAM halted
6	—	0	R/W	Reserved  This bit is always read as 0. The write value should always be 0.
5 to 3	—	All 1	R/W	Reserved  These bits are always read as 1. The write value should always be 1.
2 to 0	—	All 0	R	Reserved  These bits are always read as 0. The write value should always be 0.

### 19.3.3 Standby Control Register 3 (STBCR3)

STBCR3 is an 8-bit readable/writable register that controls the operation of modules in power-down mode.

Bit:	7	6	5	4	3	2	1	0
	-	-	MSTP 13	MSTP 12	MSTP 11	-	-	-
Initial value:	1	1	1	1	1	1	1	1
R/W:	R/W	R/W	R/W	R/W	R/W	R/W	R/W	R/W

Bit	Bit Name	Initial Value	R/W	Description
7, 6	—	All 1	R/W	Reserved  These bits are always read as 1. The write value should always be 1.
5	MSTP13	1	R/W	Module Stop Bit 13  When this bit is set to 1, the supply of the clock to the SCI_2 is halted.  0: SCI_2 operates 1: Clock supply to SCI_2 halted
4	MSTP12	1	R/W	Module Stop Bit 12  When this bit is set to 1, the supply of the clock to the SCI_1 is halted.  0: SCI_1 operates 1: Clock supply to SCI_1 halted
3	MSTP11	1	R/W	Module Stop Bit 11  When this bit is set to 1, the supply of the clock to the SCI_0 is halted.  0: SCI_0 operates 1: Clock supply to SCI_0 halted
2 to 0	—	All 1	R/W	Reserved  These bits are always read as 1. The write value should always be 1.

### 19.3.4 Standby Control Register 4 (STBCR4)

STBCR4 is an 8-bit readable/writable register that controls the operation of modules in power-down mode.

Bit:	7	6	5	4	3	2	1	0
	-	MSTP 22	MSTP 21	-	-	-	MSTP 17	MSTP 16
Initial value:	1	1	1	1	1	1	1	1
R/W:	R/W	R/W	R/W	R	R	R/W	R/W	R/W

Bit	Bit Name	Initial Value	R/W	Description
7	—	1	R/W	Reserved  This bit is always read as 1. The write value should always be 1.
6	MSTP22	1	R/W	Module Stop Bit 22  When this bit is set to 1, the supply of the clock to the MTU2 is halted. 0: MTU2 operates 1: Clock supply to MTU2 halted
5	MSTP21	1	R/W	Module Stop Bit 21  When this bit is set to 1, the supply of the clock to the CMT is halted. 0: CMT operates 1: Clock supply to CMT halted
4, 3	—	All 1	R	Reserved  These bits are always read as 1. The write value should always be 1.
2	—	1	R/W	Reserved  This bit is always read as 1. The write value should always be 1.
1	MSTP17	1	R/W	Module Stop Bit 17  When this bit is set to 1, the supply of the clock to the A/D_1 is halted. 0: A/D_1 operates 1: Clock supply to A/D_1 halted

Bit	Bit Name	Initial Value	R/W	Description
0	MSTP16	1	R/W	Module Stop Bit 16 When this bit is set to 1, the supply of the clock to the A/D_0 is halted. 0: A/D_0 operates 1: Clock supply to A/D_0 halted

### 19.3.5 Standby Control Register 5 (STBCR5)

STBCR5 is an 8-bit readable/writable register that controls the operation of modules in power-down mode.

Bit:	7	6	5	4	3	2	1	0
	-	-	-	-	-	-	MSTP[25:24]	
Initial value:	0	0	0	0	0	0	1	1
R/W:	R	R	R	R	R	R	R/W	R/W

Bit	Bit Name	Initial Value	R/W	Description
7 to 2	—	All 0	R	Reserved These bits are always read as 0. The write value should always be 0.
1, 0	MSTP[25:24]	11	R/W	Module Stop Bit 25 and 24 When either or both of these bits are set to 1, the supply of the clock to the UBC is halted. 00: UBC operates 01: Setting prohibited 10: Setting prohibited 11: Clock supply to UBC halted



### 19.3.6 Standby Control Register 6 (STBCR6)

STBCR6 is an 8-bit readable/writable register that specifies the state of the power-down modes.

Bit:	7	6	5	4	3	2	1	0
	UBC RST	HIZ	-	-	-	-	STBY MD	-
Initial value:	0	0	0	0	0	0	0	0
R/W:	R/W	R/W	R	R	R	R	R/W	R

Bit	Bit Name	Initial Value	R/W	Description
7	UBCRST	0	R/W	<p>UBC Software Reset</p> <p>Resetting the PC trace unit of UBC is controlled by software.</p> <p>Clearing this bit to 0 puts the PC trace unit of the UBC module into the power-on reset state.</p> <p>0: Puts the PC trace unit of UBC into the reset state 1: Releases reset in the PC trace unit of UBC</p>
6	HIZ	0	R/W	<p>Port High-Impedance</p> <p>In software standby mode, this bit selects whether the pin state is retained or changed to high-impedance.</p> <p>0: In software standby mode, the pin state is retained 1: In software standby mode, the pin state is changed to high-impedance</p>
5 to 2	—	All 0	R	<p>Reserved</p> <p>These bits are always read as 0. The write value should always be 0.</p>
1	STBYMD	0	R/W	<p>Software Standby Mode Select</p> <p>If this bit is set to 1, executing SLEEP instruction with the STBY bit in STBCR1 is 1 and makes transition to software standby mode.</p> <p>0: Setting prohibited 1: Makes transition to software standby mode</p>
0	—	0	R	<p>Reserved</p> <p>This bit is always read as 0. The write value should always be 0.</p>

### 19.3.7 RAM Control Register (RAMCR)

RAMCR is an 8-bit readable/writable register that enables/disables the access to the on-chip RAM.

Bit:	7	6	5	4	3	2	1	0
	-	-	-	RAME	-	-	-	-
Initial value:	0	0	0	1	0	0	0	0
R/W:	R	R	R	R/W	R	R	R	R

Bit	Bit Name	Initial Value	R/W	Description
7 to 5	—	All 0	R	Reserved  These bits are always read as 0. The write value should always be 0.
4	RAME	1	R/W	RAM Enable  This bit enables/disables the on-chip RAM. 0: On-chip RAM disabled 1: On-chip RAM enabled  When this bit is cleared to 0, the access to the on-chip RAM is disabled. In this case, an undefined value is returned when reading or fetching the data or instruction from the on-chip RAM, and writing to the on-chip RAM is ignored.  When RAME is cleared to 0 to disable the on-chip RAM, an instruction to access the on-chip RAM should not be set next to the instruction to write RAMCR. If such an instruction is set, normal access is not guaranteed.  When RAME is set to 1 to enable the on-chip RAM, an instruction to read RAMCR should be set next to the instruction to write to RAMCR. If an instruction to access the on-chip RAM is set next to the instruction to write to RAMCR, normal access is not guaranteed.
3 to 0	—	All 0	R	Reserved  These bits are always read as 0. The write value should always be 0.

## 19.4 Sleep Mode

### 19.4.1 Transition to Sleep Mode

Executing the SLEEP instruction when the STBY bit in STBCR1 is 0 causes a transition from the program execution state to sleep mode. Although the CPU halts immediately after executing the SLEEP instruction, the contents of its internal registers remain unchanged. The on-chip peripheral modules continue to operate.

### 19.4.2 Canceling Sleep Mode

Sleep mode is canceled by a reset.

#### (1) Canceling with Reset

Sleep mode is canceled by a power-on reset with the  $\overline{\text{RES}}$  pin, a manual reset with the  $\overline{\text{MRES}}$  pin, or an internal power-on/manual reset by WDT. Do not cancel sleep mode with an interrupt.

## 19.5 Software Standby Mode

### 19.5.1 Transition to Software Standby Mode

This LSI switches from a program execution state to software standby mode by executing the SLEEP instruction when the STBY bit in STBCR1 and the STBYMD bit in STBCR6 are set to 1. In software standby mode, not only the CPU but also the clock and on-chip peripheral modules halt.

The contents of the CPU registers and the data of the on-chip RAM remain unchanged. Some registers of on-chip peripheral modules are, however, initialized. For details on the states of on-chip peripheral module registers in software standby mode, refer to section 20.3, Register States in Each Operating Mode. For details on the pin states in software standby mode, refer to appendix A, Pin States.

The procedure for switching to software standby mode is as follows:

1. Clear the TME bit in the timer control register (WTCSR) of the WDT to 0 to stop the WDT.
2. Set the timer counter (WTCNT) of the WDT to 0 and bits CKS2 to CKS0 in WTCSR to appropriate values to secure the specified oscillation settling time.
3. After setting the STBY bit in STBCR1 and the STBYMD bit in STBCR6 to 1, execute the SLEEP instruction.
4. Software standby mode is entered and the clocks within this LSI are halted.

## 19.5.2 Canceling Software Standby Mode

Software standby mode is canceled by interrupts (NMI, IRQ) or a reset.

### (1) Canceling with Interrupt

The WDT can be used for hot starts. When an NMI or IRQ interrupt (edge detection) is detected, the clock will be supplied to the entire LSI and software standby mode will be canceled after the time set in the timer control/status register of the WDT has elapsed. Interrupt exception handling is then executed.

When the priority level of an IRQ interrupt is lower than the interrupt mask level set in the status register (SR) of the CPU, an interrupt request is not accepted preventing software standby mode from being canceled.

When falling-edge detection is selected for the NMI pin, drive the NMI pin high before making a transition to software standby mode. When rising-edge detection is selected for the NMI pin, drive the NMI pin low before making a transition to software standby mode.

Similarly, when falling-edge detection is selected for the IRQ pin, drive the IRQ pin high before making a transition to software standby mode. When rising-edge detection is selected for the IRQ pin, drive the IRQ pin low before making a transition to software standby mode.

### (2) Canceling with Power-on Reset

Software standby mode is canceled by a power-on reset with the  $\overline{\text{RES}}$  pin. Keep the  $\overline{\text{RES}}$  pin low until the clock oscillation settles.

### (3) Canceling with Manual Reset

Note that software standby mode cannot be canceled with a manual reset in this LSI.

## 19.6 Module Standby Mode

### 19.6.1 Transition to Module Standby Mode

Setting the MSTP bits in the standby control registers (STBCR2 to STBCR5) to 1 halts the supply of clocks to the corresponding on-chip peripheral modules. This function can be used to reduce the power consumption in normal mode.

Do not access registers of an on-chip peripheral module, which has been set to enter module standby mode. For details on the states of on-chip peripheral module registers in module standby mode, refer to section 20.3, Register States in Each Operating Mode.

### 19.6.2 Canceling Module Standby Function

The module standby function can be canceled by clearing the MSTP bits in STBCR2 to STBCR5 to 0. The module standby function can be canceled by a power-on reset for modules whose MSTP bit has an initial value of 0.

## 19.7 Usage Note

### 19.7.1 Current Consumption while Waiting for Oscillation to be Stabilized

The current consumption while waiting for oscillation to be stabilized is higher than that while oscillation is stabilized.

### 19.7.2 Executing the SLEEP Instruction

Apply either of the following measures before executing the SLEEP instruction to initiate the transition to sleep mode or software standby mode.

Measure A: Stop the generation of interrupts from on-chip peripheral modules, IRQ interrupts, and the NMI interrupt before executing the SLEEP instruction.

Measure B: Change the value in FRQCR to the initial value, H'36DB, and then dummy-read FRQCR twice before executing the SLEEP instruction.

## Section 20 List of Registers

This section gives information on internal I/O registers. The contents of this section are as follows:

1. Register Address Table (in the order from a lower address)
  - Registers are listed in the order from lower allocated addresses.
  - As for reserved addresses, the register name column is indicated with —. Do not access reserved addresses.
  - As for 16- or 32-bit address, the MSB addresses are shown.
  - The list is classified according to module names.
  - The numbers of access cycles are given.
2. Register Bit Table
  - Bit configurations are shown in the order of the register address table.
  - As for reserved bits, the bit name column is indicated with —.
  - As for the blank column of the bit names, the whole register is allocated to the counter or data.
  - As for 16- or 32-bit registers, bits are indicated from the MSB.
3. Register State in Each Operating Mode
  - Register states are listed in the order of the register address table.
  - Register states in the basic operating mode are shown. As for modules including their specific states such as reset, see the sections of those modules.

## 20.1 Register Address Table (In the Order from Lower Addresses)

Access sizes are indicated with the number of bits. Access states are indicated with the number of specified reference clock states. These values are those at 8-bit access (B), 16-bit access (W), or 32-bit access (L).

Note: Access to undefined or reserved addresses is prohibited. Correct operation cannot be guaranteed if these addresses are accessed.

Register Name	Abbreviation	Number of Bits	Address	Module	Access Size	Number of Access States
Serial mode register_0	SCSMR_0	8	H'FFFFFFC000	SCI	8	P $\phi$ reference
Bit rate register_0	SCBRR_0	8	H'FFFFFFC002	(Channel 0)	8	B: 2
Serial control register_0	SCSCR_0	8	H'FFFFFFC004		8	
Transmit data register_0	SCTDR_0	8	H'FFFFFFC006		8	
Serial status register_0	SCSSR_0	8	H'FFFFFFC008		8	
Receive data register_0	SCRDR_0	8	H'FFFFFFC00A		8	
Serial direction control register_0	SCSDCR_0	8	H'FFFFFFC00C		8	
Serial port register_0	SCSPTR_0	8	H'FFFFFFC00E		8	
Serial mode register_1	SCSMR_1	8	H'FFFFFFC080	SCI	8	P $\phi$ reference
Bit rate register_1	SCBRR_1	8	H'FFFFFFC082	(Channel 1)	8	B: 2
Serial control register_1	SCSCR_1	8	H'FFFFFFC084		8	
Transmit data register_1	SCTDR_1	8	H'FFFFFFC086		8	
Serial status register_1	SCSSR_1	8	H'FFFFFFC088		8	
Receive data register_1	SCRDR_1	8	H'FFFFFFC08A		8	
Serial direction control register_1	SCSDCR_1	8	H'FFFFFFC08C		8	
Serial port register_1	SCSPTR_1	8	H'FFFFFFC08E		8	
Serial mode register_2	SCSMR_2	8	H'FFFFFFC100	SCI	8	P $\phi$ reference
Bit rate register_2	SCBRR_2	8	H'FFFFFFC102	(Channel 2)	8	B: 2
Serial control register_2	SCSCR_2	8	H'FFFFFFC104		8	
Transmit data register_2	SCTDR_2	8	H'FFFFFFC106		8	
Serial status register_2	SCSSR_2	8	H'FFFFFFC108		8	
Receive data register_2	SCRDR_2	8	H'FFFFFFC10A		8	
Serial direction control register_2	SCSDCR_2	8	H'FFFFFFC10C		8	
Serial port register_2	SCSPTR_2	8	H'FFFFFFC10E		8	



Register Name	Abbreviation	Number of		Module	Access Size	Number of Access States
		Bits	Address			
Timer control register_3	TCR_3	8	H'FFFC200	MTU2	8, 16, 32	MP $\phi$ reference
Timer control register_4	TCR_4	8	H'FFFC201		8	B: 2, W: 2, L: 4
Timer mode register_3	TMDR_3	8	H'FFFC202		8, 16	
Timer mode register_4	TMDR_4	8	H'FFFC203		8	
Timer I/O control register H_3	TIORH_3	8	H'FFFC204		8, 16, 32	
Timer I/O control register L_3	TIORL_3	8	H'FFFC205		8	
Timer I/O control register H_4	TIORH_4	8	H'FFFC206		8, 16	
Timer I/O control register L_4	TIORL_4	8	H'FFFC207		8	
Timer interrupt enable register_3	TIER_3	8	H'FFFC208		8, 16	
Timer interrupt enable register_4	TIER_4	8	H'FFFC209		8	
Timer output master enable register	TOER	8	H'FFFC20A		8	
Timer gate control register	TGCR	8	H'FFFC20D		8	
Timer output control register 1	TOCR1	8	H'FFFC20E		8, 16	
Timer output control register 2	TOCR2	8	H'FFFC20F		8	
Timer counter_3	TCNT_3	16	H'FFFC210		16, 32	
Timer counter_4	TCNT_4	16	H'FFFC212		16	
Timer cycle data register	TCDR	16	H'FFFC214		16, 32	
Timer dead time data register	TDDR	16	H'FFFC216		16	
Timer general register A_3	TGRA_3	16	H'FFFC218		16, 32	
Timer general register B_3	TGRB_3	16	H'FFFC21A		16	
Timer general register A_4	TGRA_4	16	H'FFFC21C		16, 32	
Timer general register B_4	TGRB_4	16	H'FFFC21E		16	
Timer sub-counter	TCNTS	16	H'FFFC220		16, 32	
Timer cycle buffer register	TGBR	16	H'FFFC222		16	
Timer general register C_3	TGRC_3	16	H'FFFC224		16, 32	
Timer general register D_3	TGRD_3	16	H'FFFC226		16	
Timer general register C_4	TGRC_4	16	H'FFFC228		16, 32	
Timer general register D_4	TGRD_4	16	H'FFFC22A		16	
Timer status register_3	TSR_3	8	H'FFFC22C		8, 16	
Timer status register_4	TSR_4	8	H'FFFC22D		8	
Timer interrupt skipping set register	TITCR	8	H'FFFC230		8, 16	

## Section 20 List of Registers

Register Name	Abbreviation	Number of		Module	Access Size	Number of Access States
		Bits	Address			
Timer interrupt skipping counter	TITCNT	8	H'FFFFC231	MTU2	8	MP $\phi$ reference
Timer buffer transfer set register	TBTER	8	H'FFFFC232		8	B: 2, W: 2, L: 4
Timer dead time enable register	TDER	8	H'FFFFC234		8	
Timer output level buffer register	TOLBR	8	H'FFFFC236		8	
Timer buffer operation transfer mode register_3	TBTM_3	8	H'FFFFC238		8, 16	
Timer buffer operation transfer mode register_4	TBTM_4	8	H'FFFFC239		8	
Timer A/D converter start request control register	TADCR	16	H'FFFFC240		16	
Timer A/D converter start request cycle set register A_4	TADCORA_4	16	H'FFFFC244		16, 32	
Timer A/D converter start request cycle set register B_4	TADCORB_4	16	H'FFFFC246		16	
Timer A/D converter start request cycle set buffer register A_4	TADCOBRA_4	16	H'FFFFC248		16, 32	
Timer A/D converter start request cycle set buffer register B_4	TADCOBRB_4	16	H'FFFFC24A		16	
Timer waveform control register	TWCR	8	H'FFFFC260		8	
Timer start register	TSTR	8	H'FFFFC280		8, 16	
Timer synchronous register	TSYR	8	H'FFFFC281		8	
Timer read/write enable register	TRWER	8	H'FFFFC284		8	
Timer control register_0	TCR_0	8	H'FFFFC300		8, 16, 32	
Timer mode register_0	TMDR_0	8	H'FFFFC301		8	
Timer I/O control register H_0	TIORH_0	8	H'FFFFC302		8, 16	
Timer I/O control register L_0	TIORL_0	8	H'FFFFC303		8	
Timer interrupt enable register_0	TIER_0	8	H'FFFFC304		8, 16, 32	
Timer status register_0	TSR_0	8	H'FFFFC305		8	
Timer counter_0	TCNT_0	16	H'FFFFC306		16	
Timer general register A_0	TGRA_0	16	H'FFFFC308		16, 32	
Timer general register B_0	TGRB_0	16	H'FFFFC30A		16	

Register Name	Abbreviation	Number of		Module	Access Size	Number of Access States
		Bits	Address			
Timer general register C_0	TGRC_0	16	H'FFFFFF30C	MTU2	16, 32	MP $\phi$ reference
Timer general register D_0	TGRD_0	16	H'FFFFFF30E		16	B: 2, W: 2, L: 4
Timer general register E_0	TGRE_0	16	H'FFFFFF320		16, 32	
Timer general register F_0	TGRF_0	16	H'FFFFFF322		16	
Timer interrupt enable register 2_0	TIER2_0	8	H'FFFFFF324		8, 16	
Timer status register 2_0	TSR2_0	8	H'FFFFFF325		8	
Timer buffer operation transfer mode register_0	TBTM_0	8	H'FFFFFF326		8	
Timer control register_1	TCR_1	8	H'FFFFFF380		8, 16	
Timer mode register_1	TMDR_1	8	H'FFFFFF381		8	
Timer I/O control register_1	TIOR_1	8	H'FFFFFF382		8	
Timer interrupt enable register_1	TIER_1	8	H'FFFFFF384		8, 16, 32	
Timer status register_1	TSR_1	8	H'FFFFFF385		8	
Timer counter_1	TCNT_1	16	H'FFFFFF386		16	
Timer general register A_1	TGRA_1	16	H'FFFFFF388		16, 32	
Timer general register B_1	TGRB_1	16	H'FFFFFF38A		16	
Timer input capture control register	TICCR	8	H'FFFFFF390		8	
Timer control register_2	TCR_2	8	H'FFFFFF400		8, 16	
Timer mode register_2	TMDR_2	8	H'FFFFFF401		8	
Timer I/O control register_2	TIOR_2	8	H'FFFFFF402		8	
Timer interrupt enable register_2	TIER_2	8	H'FFFFFF404		8, 16, 32	
Timer status register_2	TSR_2	8	H'FFFFFF405		8	
Timer counter_2	TCNT_2	16	H'FFFFFF406		16	
Timer general register A_2	TGRA_2	16	H'FFFFFF408		16, 32	
Timer general register B_2	TGRB_2	16	H'FFFFFF40A		16	
Timer counter U_5	TCNTU_5	16	H'FFFFFF480		16, 32	
Timer general register U_5	TGRU_5	16	H'FFFFFF482		16	
Timer control register U_5	TCRU_5	8	H'FFFFFF484		8	
Timer I/O control register U_5	TIORU_5	8	H'FFFFFF486		8	
Timer counter V_5	TCNTV_5	16	H'FFFFFF490		16, 32	
Timer general register V_5	TGRV_5	16	H'FFFFFF492		16	

## Section 20 List of Registers

Register Name	Abbreviation	Number of		Module	Access Size	Number of Access States
		Bits	Address			
Timer control register V_5	TCRV_5	8	H'FFFFFFC494	MTU2	8	MP $\phi$ reference
Timer I/O control register V_5	TIORV_5	8	H'FFFFFFC496		8	B: 2, W: 2, L: 4
Timer counter W_5	TCNTW_5	16	H'FFFFFFC4A0		16, 32	
Timer general register W_5	TGRW_5	16	H'FFFFFFC4A2		16	
Timer control register W_5	TCRW_5	8	H'FFFFFFC4A4		8	
Timer I/O control register W_5	TIORW_5	8	H'FFFFFFC4A6		8	
Timer status register_5	TSR_5	8	H'FFFFFFC4B0		8	
Timer interrupt enable register_5	TIER_5	8	H'FFFFFFC4B2		8	
Timer start register_5	TSTR_5	8	H'FFFFFFC4B4		8	
Timer compare match clear register	TCNTCMPCLR	8	H'FFFFFFC4B6		8	
A/D data register 0	ADDR0	16	H'FFFFFFC900	A/D	16	P $\phi$ reference
A/D data register 1	ADDR1	16	H'FFFFFFC902	(Channel 0)	16	B: 2, W: 2
A/D data register 2	ADDR2	16	H'FFFFFFC904		16	
A/D data register 3	ADDR3	16	H'FFFFFFC906		16	
A/D control/status register_0	ADCSR_0	16	H'FFFFFFC910		16	
A/D control register_0	ADCR_0	16	H'FFFFFFC912		16	
A/D data register 4	ADDR4	16	H'FFFFFFC980	A/D	16	P $\phi$ reference
A/D data register 5	ADDR5	16	H'FFFFFFC982	(Channel 1)	16	B: 2, W: 2
A/D data register 6	ADDR6	16	H'FFFFFFC984		16	
A/D data register 7	ADDR7	16	H'FFFFFFC986		16	
A/D control/status register_1	ADCSR_1	16	H'FFFFFFC990		16	
A/D control register_1	ADCR_1	16	H'FFFFFFC992		16	
Flash code control/status register	FCCS	8	H'FFFFFFC00	FLASH	8	P $\phi$ reference
Flash program code select register	FPCS	8	H'FFFFFFC01		8	B: 5
Flash erase code select register	FECS	8	H'FFFFFFC02		8	
Flash key code register	FKEY	8	H'FFFFFFC04		8	
Flash transfer destination address register	FTDAR	8	H'FFFFFFC06		8	

Register Name	Abbreviation	Number of		Module	Access Size	Number of Access States
		Bits	Address			
Compare match timer start register	CMSTR	16	H'FFFFCE00	CMT	8, 16, 32	P $\phi$ reference
Compare match timer control/status register_0	CMCSR_0	16	H'FFFFCE02		8, 16	B: 2, W: 2, L: 4
Compare match counter_0	CMCNT_0	16	H'FFFFCE04		8, 16, 32	
Compare match constant register_0	CMCOR_0	16	H'FFFFCE06		8, 16	
Compare match timer control/status register_1	CMCSR_1	16	H'FFFFCE08		8, 16, 32	
Compare match counter_1	CMCNT_1	16	H'FFFFCE0A		8, 16	
Compare match constant register_1	CMCOR_1	16	H'FFFFCE0C		8, 16, 32	
Input level control/status register 1	ICSR1	16	H'FFFFD000	POE	8, 16, 32	P $\phi$ reference
Output level control/status register 1	OCSR1	16	H'FFFFD002		8, 16	B: 2, W: 2, L: 4
Input level control/status register 3	ICSR3	16	H'FFFFD008		8, 16	
Software port output enable register	SPOER	8	H'FFFFD00A		8	
Port output enable control register 1	POECR1	8	H'FFFFD00B		8	
Port output enable control register 2	POECR2	16	H'FFFFD00C		8, 16	
Port A data register L	PADRL	16	H'FFFFD102	I/O	8, 16	P $\phi$ reference
Port A I/O register L	PAIORL	16	H'FFFFD106	PFC	8, 16	B: 2, W: 2, L: 4
Port A control register L4	PACRL4	16	H'FFFFD110		8, 16, 32	
Port A control register L3	PACRL3	16	H'FFFFD112		8, 16	
Port A control register L2	PACRL2	16	H'FFFFD114		8, 16, 32	
Port A control register L1	PACRL1	16	H'FFFFD116		8, 16	
Port A port register L	PAPRL	16	H'FFFFD11E	I/O	8, 16	
Port B data register H	PBDRH	16	H'FFFFD180		8, 16, 32	
Port B data register L	PBDRL	16	H'FFFFD182		8, 16	
Port B I/O register H	PBIORH	16	H'FFFFD184	PFC	8, 16, 32	
Port B I/O register L	PBIORL	16	H'FFFFD186		8, 16	
Port B control register H1	PBCRH1	16	H'FFFFD18E		8, 16	
Port B control register L2	PBCRL2	16	H'FFFFD194		8, 16, 32	
Port B control register L1	PBCRL1	16	H'FFFFD196		8, 16	
Port B port register H	PBPRH	16	H'FFFFD19C	I/O	8, 16, 32	
Port B port register L	PBPRL	16	H'FFFFD19E		8, 16	
Port E data register L	PEDRL	16	H'FFFFD302		8, 16	

## Section 20 List of Registers

Register Name	Abbreviation	Number of		Module	Access Size	Number of Access States
		Bits	Address			
Port E I/O register L	PEIORL	16	H'FFFFD306	PFC	8, 16	P $\phi$ reference
Port E control register L4	PECRL4	16	H'FFFFD310		8, 16, 32	B: 2, W: 2, L: 4
Port E control register L3	PECRL3	16	H'FFFFD312		8, 16	
Port E control register L2	PECRL2	16	H'FFFFD314		8, 16, 32	
Port E control register L1	PECRL1	16	H'FFFFD316		8, 16	
Port E port register L	PEPRL	16	H'FFFFD31E	I/O	8, 16	
IRQOUT function control register	IFCR	16	H'FFFFD322	PFC	8, 16	
Port F data register L	PFDRL	16	H'FFFFD382	I/O	8, 16	
Frequency control register	FRQCR	16	H'FFFFE800	CPG	16	P $\phi$ reference W: 2
Standby control register 1	STBCR1	8	H'FFFFE802	Power-down modes	8	P $\phi$ reference
Standby control register 2	STBCR2	8	H'FFFFE804		8	B: 2
Standby control register 3	STBCR3	8	H'FFFFE806		8	
Standby control register 4	STBCR4	8	H'FFFFE808		8	
Standby control register 5	STBCR5	8	H'FFFFE80A		8	
Standby control register 6	STBCR6	8	H'FFFFE80C		8	
Watchdog timer counter	WTCNT	8	H'FFFFE810	WDT	8* <sup>1</sup> , 16* <sup>2</sup>	P $\phi$ reference
Watchdog timer control/status register	WTCSR	8	H'FFFFE812	*1: Read *2: Write	8* <sup>1</sup> , 16* <sup>2</sup>	B: 2* <sup>1</sup> , W: 2* <sup>2</sup>
Oscillation stop detection control register	OSCCR	8	H'FFFFE814	CPG	8	P $\phi$ reference B: 2
RAM control register	RAMCR	8	H'FFFFE880	Power-down modes	8	P $\phi$ reference B: 2
A/D trigger select register_0	ADTSR_0	16	H'FFFFE890	A/D	8, 16	P $\phi$ reference B: 2, W: 2
Interrupt control register 0	ICR0	16	H'FFFFE900	INTC	8, 16	P $\phi$ reference
IRQ control register	IRQCR	16	H'FFFFE902		8, 16	B: 2, W: 2
IRQ status register	IRQSR	16	H'FFFFE904		8, 16	
Interrupt priority register A	IPRA	16	H'FFFFE906		8, 16	
Interrupt priority register B	IPRB	16	H'FFFFE908		8, 16	
Interrupt priority register C	IPRC	16	H'FFFFE980		16	

Register Name	Abbreviation	Number of		Module	Access Size	Number of Access States
		Bits	Address			
Interrupt priority register D	IPRD	16	H'FFFFE982	INTC	16	P $\phi$ reference
Interrupt priority register E	IPRE	16	H'FFFFE984		16	B: 2, W: 2
Interrupt priority register F	IPRF	16	H'FFFFE986		16	
Interrupt priority register H	IPRH	16	H'FFFFE98A		16	
Interrupt priority register I	IPRI	16	H'FFFFE98C		16	
Interrupt priority register J	IPRJ	16	H'FFFFE98E		16	
Interrupt priority register K	IPRK	16	H'FFFFE990		16	
Interrupt priority register L	IPRL	16	H'FFFFE992		16	
Interrupt priority register M	IPRM	16	H'FFFFE994		16	
Break address register A	BARA	32	H'FFFFF300	UBC	32	B $\phi$ reference
Break address mask register A	BAMRA	32	H'FFFFF304		32	B: 2, W: 2, L: 2
Break bus cycle register A	BBRA	16	H'FFFFF308		16	
Break data register A	BDRA	32	H'FFFFF310		32	
Break data mask register A	BDMRA	32	H'FFFFF314		32	
Break address register B	BARB	32	H'FFFFF320		32	
Break address mask register B	BAMRB	32	H'FFFFF324		32	
Break bus cycle register B	BBRB	16	H'FFFFF328		16	
Break data register B	BDRB	32	H'FFFFF330		32	
Break data mask register B	BDMRB	32	H'FFFFF334		32	
Break control register	BRCR	32	H'FFFFF3C0		32	
Branch source register	BRSR	32	H'FFFFF3D0		32	
Branch destination register	BRDR	32	H'FFFFF3D4		32	
Execution times break register	BETR	16	H'FFFFF3DC		16	

## 20.2 Register Bit List

Addresses and bit names of each on-chip peripheral module are shown below.

As for 16-bit or 32-bit registers, they are shown in two or four rows.

Register Abbreviation	Bit 31/23/15/7	Bit 30/22/14/6	Bit 29/21/13/5	Bit 28/20/12/4	Bit 27/19/11/3	Bit 26/18/10/2	Bit 25/17/9/1	Bit 24/16/8/0	Module
SCSMR_0	C/ $\bar{A}$	CHR	PE	O/ $\bar{E}$	STOP	MP	CKS[1:0]		SCI (Channel 0)
SCBRR_0									
SCSCR_0	TIE	RIE	TE	RE	MPIE	TEIE	CKE[1:0]		
SCTDR_0									
SCSSR_0	TDRE	RDRF	ORER	FER	PER	TEND	MPB	MPBT	
SCRDR_0									
SCSDCR_0	—	—	—	—	DIR	—	—	—	
SCSPTR_0	EIO	—	—	—	SPB1IO	SPB1DT	SPB0IO	SPB0DT	
SCSMR_1	C/ $\bar{A}$	CHR	PE	O/ $\bar{E}$	STOP	MP	CKS[1:0]		
SCBRR_1									
SCSCR_1	TIE	RIE	TE	RE	MPIE	TEIE	CKE[1:0]		
SCTDR_1									
SCSSR_1	TDRE	RDRF	ORER	FER	PER	TEND	MPB	MPBT	
SCRDR_1									
SCSDCR_1	—	—	—	—	DIR	—	—	—	
SCSPTR_1	EIO	—	—	—	SPB1IO	SPB1DT	SPB0IO	SPB0DT	
SCSMR_2	C/ $\bar{A}$	CHR	PE	O/ $\bar{E}$	STOP	MP	CKS[1:0]		SCI (Channel 2)
SCBRR_2									
SCSCR_2	TIE	RIE	TE	RE	MPIE	TEIE	CKE[1:0]		
SCTDR_2									
SCSSR_2	TDRE	RDRF	ORER	FER	PER	TEND	MPB	MPBT	
SCRDR_2									
SCSDCR_2	—	—	—	—	DIR	—	—	—	
SCSPTR_2	EIO	—	—	—	SPB1IO	SPB1DT	SPB0IO	SPB0DT	



Register Abbreviation	Bit 31/23/15/7	Bit 30/22/14/6	Bit 29/21/13/5	Bit 28/20/12/4	Bit 27/19/11/3	Bit 26/18/10/2	Bit 25/17/9/1	Bit 24/16/8/0	Module
TCR_3	CCLR[2:0]			CKEG[1:0]		TPSC[2:0]			MTU2
TCR_4	CCLR[2:0]			CKEG[1:0]		TPSC[2:0]			
TMDR_3	—	—	BFB	BFA	MD[3:0]				
TMDR_4	—	—	BFB	BFA	MD[3:0]				
TIORH_3	IOB[3:0]				IOA[3:0]				
TIORL_3	IOD[3:0]				IOC[3:0]				
TIORH_4	IOB[3:0]				IOA[3:0]				
TIORL_4	IOD[3:0]				IOC[3:0]				
TIER_3	TTGE	—	—	TCIEV	TGIED	TGIEC	TGIEB	TGIEA	
TIER_4	TTGE	TTGE2	—	TCIEV	TGIED	TGIEC	TGIEB	TGIEA	
TOER	—	—	OE4D	OE4C	OE3D	OE4B	OE4A	OE3B	
TGCR	—	BDC	N	P	FB	WF	VF	UF	
TOCR1	—	PSYE	—	—	TOCL	TOCS	OLSN	OLSP	
TOCR2	BF[1:0]		OLS3N	OLS3P	OLS2N	OLS2P	OLS1N	OLS1P	
TCNT_3									
TCNT_4									
TCDR									
TDDR									
TGRA_3									
TGRB_3									
TGRA_4									
TGRB_4									

Register Abbreviation	Bit 31/23/15/7	Bit 30/22/14/6	Bit 29/21/13/5	Bit 28/20/12/4	Bit 27/19/11/3	Bit 26/18/10/2	Bit 25/17/9/1	Bit 24/16/8/0	Module
TCNTS									MTU2
TCBR									
TGRC_3									
TGRD_3									
TGRC_4									
TGRD_4									
TSR_3	TCFD	—	—	TCFV	TGFD	TGFC	TGFB	TGFA	
TSR_4	TCFD	—	—	TCFV	TGFD	TGFC	TGFB	TGFA	
TITCR	T3AEN	3ACOR[2:0]			T4VEN	4VCOR[2:0]			
TITCNT	—	3ACNT[2:0]			—	4VCNT[2:0]			
TBTER	—	—	—	—	—	—	BTE[1:0]		
TDER	—	—	—	—	—	—	—	TDER	
TOLBR	—	—	OLS3N	OLS3P	OLS2N	OLS2P	OLS1N	OLS1P	
TBTM_3	—	—	—	—	—	—	TTSB	TTSA	
TBTM_4	—	—	—	—	—	—	TTSB	TTSA	
TADCR	BF[1:0]		—	—	—	—	—	—	
	UT4AE	DT4AE	UT4BE	DT4BE	ITA3AE	ITA4VE	ITB3AE	ITB4VE	
TADCORA_4									
TADCORB_4									
TADCOBRA_4									
TADCOBRB_4									

Register Abbreviation	Bit 31/23/15/7	Bit 30/22/14/6	Bit 29/21/13/5	Bit 28/20/12/4	Bit 27/19/11/3	Bit 26/18/10/2	Bit 25/17/9/1	Bit 24/16/8/0	Module
TWCR	CCE	—	—	—	—	—	—	WRE	MTU2
TSTR	CST4	CST3	—	—	—	CST2	CST1	CST0	
TSYR	SYNC4	SYNC3	—	—	—	SYNC2	SYNC1	SYNC0	
TRWER	—	—	—	—	—	—	—	RWE	
TCR_0	CCLR[2:0]			CKEG[1:0]		TPSC[2:0]			
TMDR_0	—	BFE	BFB	BFA	MD[3:0]				
TIORH_0	IOB[3:0]				IOA[3:0]				
TIORL_0	IOD[3:0]				IOC[3:0]				
TIER_0	TTGE	—	—	TCIEV	TGIED	TGIEC	TGIEB	TGIEA	
TSR_0	—	—	—	TCFV	TGFD	TGFC	TGFB	TGFA	
TCNT_0									
TGRA_0									
TGRB_0									
TGRC_0									
TGRD_0									
TGRE_0									
TGRF_0									
TIER2_0	TTGE2	—	—	—	—	—	TGIEF	TGIEE	
TSR2_0	—	—	—	—	—	—	TGFF	TGFE	
TBTM_0	—	—	—	—	—	TTSE	TTSB	T TSA	
TCR_1	—	CCLR[1:0]		CKEG[1:0]		TPSC[2:0]			
TMDR_1	—	—	—	—	MD[3:0]				
TIOR_1	IOB[3:0]				IOA[3:0]				

Register Abbreviation	Bit 31/23/15/7	Bit 30/22/14/6	Bit 29/21/13/5	Bit 28/20/12/4	Bit 27/19/11/3	Bit 26/18/10/2	Bit 25/17/9/1	Bit 24/16/8/0	Module	
TIER_1	TTGE	—	TCIEU	TCIEV	—	—	TGIEB	TGIEA	MTU2	
TSR_1	TCFD	—	TCFU	TCFV	—	—	TGFB	TGFA		
TCNT_1										
TGRA_1										
TGRB_1										
TICCR	—	—	—	—	I2BE	I2AE	I1BE	I1AE		
TCR_2	—	CCLR[1:0]		CKEG[1:0]		TPSC[2:0]				
TMDR_2	—	—	—	—	MD[3:0]					
TIOR_2	IOB[3:0]				IOA[3:0]					
TIER_2	TTGE	—	TCIEU	TCIEV	—	—	TGIEB	TGIEA		
TSR_2	TCFD	—	TCFU	TCFV	—	—	TGFB	TGFA		
TCNT_2										
TGRA_2										
TGRB_2										
TCNTU_5										
TGRU_5										
TCRU_5	—	—	—	—	—	—	TPSC[1:0]			
TIORU_5	—	—	—	IOC[4:0]						
TCNTV_5										
TGRV_5										
TCRV_5	—	—	—	—	—	—	TPSC[1:0]			

Register Abbreviation	Bit 31/23/15/7	Bit 30/22/14/6	Bit 29/21/13/5	Bit 28/20/12/4	Bit 27/19/11/3	Bit 26/18/10/2	Bit 25/17/9/1	Bit 24/16/8/0	Module	
TIORV_5	—	—	—	IOC[4:0]					MTU2	
TCNTW_5										
TGRW_5										
TCRW_5	—	—	—	—	—	—	TPSC[1:0]			
TIORW_5	—	—	—	IOC[4:0]						
TSR_5	—	—	—	—	—	CMFU5	CMFV5	CMFW5		
TIER_5	—	—	—	—	—	TGIE5U	TGIE5V	TGIE5W		
TSTR_5	—	—	—	—	—	CSTU5	CSTV5	CSTW5		
TCNTCMPCLR	—	—	—	—	—	CMPCLR5U	CMPCLR5V	CMPCLR5W		
ADDR0	AD9	AD8	AD7	AD6	AD5	AD4	AD3	AD2		A/D (Channel 0)
	AD1	AD0	—	—	—	—	—	—		
ADDR1	AD9	AD8	AD7	AD6	AD5	AD4	AD3	AD2		
	AD1	AD0	—	—	—	—	—	—		
ADDR2	AD9	AD8	AD7	AD6	AD5	AD4	AD3	AD2		
	AD1	AD0	—	—	—	—	—	—		
ADDR3	AD9	AD8	AD7	AD6	AD5	AD4	AD3	AD2		
	AD1	AD0	—	—	—	—	—	—		
ADCSR_0	ADF	ADIE	—	—	TRGE	—	CONADF	STC		
	CKSL[1:0]		ADM[1:0]		ADCS	CH[2:0]				
ADCR_0	—	—	ADST	—	—	—	—	—		
	—	—	—	—	—	—	—	—		
ADDR4	AD9	AD8	AD7	AD6	AD5	AD4	AD3	AD2	A/D (Channel 1)	
	AD1	AD0	—	—	—	—	—	—		
ADDR5	AD9	AD8	AD7	AD6	AD5	AD4	AD3	AD2		
	AD1	AD0	—	—	—	—	—	—		
ADDR6	AD9	AD8	AD7	AD6	AD5	AD4	AD3	AD2		
	AD1	AD0	—	—	—	—	—	—		
ADDR7	AD9	AD8	AD7	AD6	AD5	AD4	AD3	AD2		
	AD1	AD0	—	—	—	—	—	—		

Register Abbreviation	Bit 31/23/15/7	Bit 30/22/14/6	Bit 29/21/13/5	Bit 28/20/12/4	Bit 27/19/11/3	Bit 26/18/10/2	Bit 25/17/9/1	Bit 24/16/8/0	Module
ADCSR_1	ADF	ADIE	—	—	TRGE	—	CONADF	STC	A/D (Channel 1)
	CKSL[1:0]		ADM[1:0]		ADCS	CH[2:0]			
ADCR_1	—	—	ADST	—	—	—	—	—	
	—	—	—	—	—	—	—	—	
FCCS	FWE	—	—	FLER	—	—	—	SCO	FLASH
FPCS	—	—	—	—	—	—	—	PPVS	
FECS	—	—	—	—	—	—	—	EPVB	
FKEY	K[7:0]								
FTDAR	TDER	TDA[6:0]							
CMSTR	—	—	—	—	—	—	—	—	CMT
	—	—	—	—	—	—	STR1	STR0	
CMCSR_0	—	—	—	—	—	—	—	—	
	CMF	CMIE	—	—	—	—	CKS[1:0]		
CMCNT_0									
CMCOR_0									
CMCSR_1	—	—	—	—	—	—	—	—	
	CMF	CMIE	—	—	—	—	CKS[1:0]		
CMCNT_1									
CMCOR_1									
ICSR1	POE3F	—	POE1F	POE0F	—	—	—	PIE1	POE
	POE3M[1:0]		—	—	POE1M[1:0]		POE0M[1:0]		
OCSR1	OSF1	—	—	—	—	—	OCE1	OIE1	
	—	—	—	—	—	—	—	—	
ICSR3	—	—	—	POE8F	—	—	POE8E	PIE3	
	—	—	—	—	—	—	POE8M[1:0]		
SPOER	—	—	—	—	—	—	MTU2CH0HIZ	MTU2CH34HIZ	

Register Abbreviation	Bit 31/23/15/7	Bit 30/22/14/6	Bit 29/21/13/5	Bit 28/20/12/4	Bit 27/19/11/3	Bit 26/18/10/2	Bit 25/17/9/1	Bit 24/16/8/0	Module
POECR1	—	—	—	—	MTU2PE3ZE	MTU2PE2ZE	MTU2PE1ZE	MTU2PE0ZE	POE
POECR2	—	MTU2P1CZE	MTU2P2CZE	MTU2P3CZE	—	—	—	—	
PADRL (SH7125)	PA15DR	PA14DR	PA13DR	PA12DR	PA11DR	PA10DR	PA9DR	PA8DR	I/O
	PA7DR	PA6DR	PA5DR	PA4DR	PA3DR	PA2DR	PA1DR	PA0DR	
PADRL (SH7124)	—	—	—	—	—	—	PA9DR	PA8DR	
	PA7DR	PA6DR	—	PA4DR	PA3DR	—	PA1DR	PA0DR	
PAIORL (SH7125)	PA15IOR	PA14IOR	PA13IOR	PA12IOR	PA11IOR	PA10IOR	PA9IOR	PA8IOR	PFC
	PA7IOR	PA6IOR	PA5IOR	PA4IOR	PA3IOR	PA2IOR	PA1IOR	PA0IOR	
PAIORL (SH7124)	—	—	—	—	—	—	PA9IOR	PA8IOR	
	PA7IOR	PA6IOR	—	PA4IOR	PA3IOR	—	PA1IOR	PA0IOR	
PACRL4 (SH7125)	—	PA15MD2	PA15MD1	PA15MD0	—	PA14MD2	PA14MD1	PA14MD0	
	—	PA13MD2	PA13MD1	PA13MD0	—	PA12MD2	PA12MD1	PA12MD0	
PACRL4 (SH7124)	—	—	—	—	—	—	—	—	
	—	—	—	—	—	—	—	—	
PACRL3 (SH7125)	—	PA11MD2	PA11MD1	PA11MD0	—	PA10MD2	PA10MD1	PA10MD0	
	—	PA9MD2	PA9MD1	PA9MD0	—	PA8MD2	PA8MD1	PA8MD0	
PACRL3 (SH7124)	—	—	—	—	—	—	—	—	
	—	PA9MD2	PA9MD1	PA9MD0	—	PA8MD2	PA8MD1	PA8MD0	
PACRL2 (SH7125)	—	PA7MD2	PA7MD1	PA7MD0	—	PA6MD2	PA6MD1	PA6MD0	
	—	PA5MD2	PA5MD1	PA5MD0	—	PA4MD2	PA4MD1	PA4MD0	
PACRL2 (SH7124)	—	PA7MD2	PA7MD1	PA7MD0	—	PA6MD2	PA6MD1	PA6MD0	
	—	—	—	—	—	PA4MD2	PA4MD1	PA4MD0	
PACRL1 (SH7125)	—	PA3MD2	PA3MD1	PA3MD0	—	PA2MD2	PA2MD1	PA2MD0	
	—	PA1MD2	PA1MD1	PA1MD0	—	PA0MD2	PA0MD1	PA0MD0	
PACRL1 (SH7124)	—	PA3MD2	PA3MD1	PA3MD0	—	—	—	—	
	—	PA1MD2	PA1MD1	PA1MD0	—	PA0MD2	PA0MD1	PA0MD0	
PAPRL (SH7125)	PA15PR	PA14PR	PA13PR	PA12PR	PA11PR	PA10PR	PA9PR	PA8PR	I/O
	PA7PR	PA6PR	PA5PR	PA4PR	PA3PR	PA2PR	PA1PR	PA0PR	
PAPRL (SH7124)	—	—	—	—	—	—	PA9PR	PA8PR	
	PA7PR	PA6PR	—	PA4PR	PA3PR	—	PA1PR	PA0PR	

Register Abbreviation	Bit 31/23/15/7	Bit 30/22/14/6	Bit 29/21/13/5	Bit 28/20/12/4	Bit 27/19/11/3	Bit 26/18/10/2	Bit 25/17/9/1	Bit 24/16/8/0	Module	
PBDRH (SH7125)	—	—	—	—	—	—	—	—	I/O	
	—	—	—	—	—	—	—	PB16DR		
PBDRH (SH7124)	—	—	—	—	—	—	—	—		
	—	—	—	—	—	—	—	—		
PBDRL (SH7125)	—	—	—	—	—	—	—	—		
	—	—	PB5DR	—	PB3DR	PB2DR	PB1DR	—		
PBDRL (SH7124)	—	—	—	—	—	—	—	—		
	—	—	PB5DR	—	PB3DR	—	PB1DR	—		
PBIORH (SH7125)	—	—	—	—	—	—	—	—		PFC
	—	—	—	—	—	—	—	PB16IOR		
PBIORH (SH7124)	—	—	—	—	—	—	—	—		
	—	—	—	—	—	—	—	—		
PBIORL (SH7125)	—	—	—	—	—	—	—	—		
	—	—	PB5IOR	—	PB3IOR	PB2IOR	PB1IOR	—		
PBIORL (SH7124)	—	—	—	—	—	—	—	—		
	—	—	PB5IOR	—	PB3IOR	—	PB1IOR	—		
PBCRH1 (SH7125)	—	—	—	—	—	—	—	—		
	—	—	—	—	—	—	—	PB16MD		
PBCRH1 (SH7124)	—	—	—	—	—	—	—	—		
	—	—	—	—	—	—	—	—		
PBCRL2 (SH7125)	—	—	—	—	—	—	—	—		
	—	PB5MD2	PB5MD1	PB5MD0	—	—	—	—		
PBCRL2 (SH7124)	—	—	—	—	—	—	—	—		
	—	PB5MD2	PB5MD1	PB5MD0	—	—	—	—		
PBCRL1 (SH7125)	—	PB3MD2	PB3MD1	PB3MD0	—	PB2MD2	PB2MD1	PB2MD0		
	—	PB1MD2	PB1MD1	PB1MD0	—	—	—	—		
PBCRL1 (SH7124)	—	PB3MD2	PB3MD1	PB3MD0	—	—	—	—		
	—	PB1MD2	PB1MD1	PB1MD0	—	—	—	—		



Register Abbreviation	Bit 31/23/15/7	Bit 30/22/14/6	Bit 29/21/13/5	Bit 28/20/12/4	Bit 27/19/11/3	Bit 26/18/10/2	Bit 25/17/9/1	Bit 24/16/8/0	Module
PBPRH (SH7125)	—	—	—	—	—	—	—	—	I/O
	—	—	—	—	—	—	—	PB16PR	
PBPRH (SH7124)	—	—	—	—	—	—	—	—	
	—	—	—	—	—	—	—	—	
PBPRL (SH7125)	—	—	—	—	—	—	—	—	
	—	—	PB5PR	—	PB3PR	PB2PR	PB1PR	—	
PBPRL (SH7124)	—	—	—	—	—	—	—	—	
	—	—	PB5PR	—	PB3PR	—	PB1PR	—	
PEDRL (SH7125)	PE15DR	PE14DR	PE13DR	PE12DR	PE11DR	PE10DR	PE9DR	PE8DR	
	PE7DR	PE6DR	PE5DR	PE4DR	PE3DR	PE2DR	PE1DR	PE0DR	
PEDRL (SH7124)	PE15DR	PE14DR	PE13DR	PE12DR	PE11DR	PE10DR	PE9DR	PE8DR	
	—	—	—	—	PE3DR	PE2DR	PE1DR	PE0DR	
PEIORL (SH7125)	PE15IOR	PE14IOR	PE13IOR	PE12IOR	PE11IOR	PE10IOR	PE9IOR	PE8IOR	PFC
	PE7IOR	PE6IOR	PE5IOR	PE4IOR	PE3IOR	PE2IOR	PE1IOR	PE0IOR	
PEIORL (SH7124)	PE15IOR	PE14IOR	PE13IOR	PE12IOR	PE11IOR	PE10IOR	PE9IOR	PE8IOR	
	—	—	—	—	PE3IOR	PE2IOR	PE1IOR	PE0IOR	
PECRL4	—	PE15MD2	PE15MD1	PE15MD0	—	PE14MD2	PE14MD1	PE14MD0	
	—	—	PE13MD1	PE13MD0	—	PE12MD2	PE12MD1	PE12MD0	
PECRL3	—	PE11MD2	PE11MD1	PE11MD0	—	PE10MD2	PE10MD1	PE10MD0	
	—	PE9MD2	PE9MD1	PE9MD0	—	PE8MD2	PE8MD1	PE8MD0	
PECRL2 (SH7125)	—	PE7MD2	PE7MD1	PE7MD0	—	PE6MD2	PE6MD1	PE6MD0	
	—	PE5MD2	PE5MD1	PE5MD0	—	PE4MD2	PE4MD1	PE4MD0	
PECRL2 (SH7124)	—	—	—	—	—	—	—	—	
	—	—	—	—	—	—	—	—	
PECRL1	—	PE3MD2	PE3MD1	PE3MD0	—	PE2MD2	PE2MD1	PE2MD0	
	—	PE1MD2	PE1MD1	PE1MD0	—	—	PE0MD1	PE0MD0	
PEPRL (SH7125)	PE15PR	PE14PR	PE13PR	PE12PR	PE11PR	PE10PR	PE9PR	PE8PR	I/O
	PE7PR	PE6PR	PE5PR	PE4PR	PE3PR	PE2PR	PE1PR	PE0PR	
PEPRL (SH7124)	PE15PR	PE14PR	PE13PR	PE12PR	PE11PR	PE10PR	PE9PR	PE8PR	
	—	—	—	—	PE3PR	PE2PR	PE1PR	PE0PR	

Register Abbreviation	Bit 31/23/15/7	Bit 30/22/14/6	Bit 29/21/13/5	Bit 28/20/12/4	Bit 27/19/11/3	Bit 26/18/10/2	Bit 25/17/9/1	Bit 24/16/8/0	Module
IFCR	—	—	—	—	—	—	—	—	PFC
	—	—	—	—	—	—	IRQMD1	IRQMD0	
PFDR	—	—	—	—	—	—	—	—	I/O
	PF7DR	PF6DR	PF5DR	PF4DR	PF3DR	PF2DR	PF1DR	PF0DR	
FRQCR	—	IFC[2:0]			BFC[2:0]			PFC[2]	CPG
	PFC[1:0]		—	—	—	MPFC[2:0]			
STBCR1	STBY	—	—	—	—	—	—	—	Power-down modes
STBCR2	MSTP7	—	—	—	—	—	—	—	
STBCR3	—	—	MSTP13	MSTP12	MSTP11	—	—	—	
STBCR4	—	MSTP22	MSTP21	—	—	—	MSTP17	MSTP16	
STBCR5	—	—	—	—	—	—	MSTP[25:24]		
STBCR6	UBCRST	HIZ	—	—	—	—	STBYMD	—	
WTCNT									WDT
WTCSR	TME	WT/IT	RSTS	WOVF	IOVF	CKS[2:0]			
OSCCR	—	—	—	—	—	OSCSTOP	—	OSCERS	CPG
RAMCR	—	—	—	RAME	—	—	—	—	Power-down modes
ADTSR_0	TRG11S[3:0]				TRG01S[3:0]				A/D
	TRG1S[3:0]				TRG0S[3:0]				
ICR0	NMIL	—	—	—	—	—	—	NMIE	INTC
	—	—	—	—	—	—	—	—	
IRQCR	—	—	—	—	—	—	—	—	
	IRQ31S	IRQ30S	IRQ21S	IRQ20S	IRQ11S	IRQ10S	IRQ01S	IRQ00S	
IRQSR	—	—	—	—	IRQ3L	IRQ2L	IRQ1L	IRQ0L	
	—	—	—	—	IRQ3F	IRQ2F	IRQ1F	IRQ0F	
IPRA	IRQ0	IRQ0	IRQ0	IRQ0	IRQ1	IRQ1	IRQ1	IRQ1	
	IRQ2	IRQ2	IRQ2	IRQ2	IRQ3	IRQ3	IRQ3	IRQ3	
IPRB	—	—	—	—	—	—	—	—	
	—	—	—	—	—	—	—	—	
IPRC	—	—	—	—	—	—	—	—	
	—	—	—	—	—	—	—	—	

Register Abbreviation	Bit 31/23/15/7	Bit 30/22/14/6	Bit 29/21/13/5	Bit 28/20/12/4	Bit 27/19/11/3	Bit 26/18/10/2	Bit 25/17/9/1	Bit 24/16/8/0	Module
IPRD	MTU2_0	MTU2_0	MTU2_0	MTU2_0	MTU2_0	MTU2_0	MTU2_0	MTU2_0	INTC
	MTU2_1	MTU2_1	MTU2_1	MTU2_1	MTU2_1	MTU2_1	MTU2_1	MTU2_1	
IPRE	MTU2_2	MTU2_2	MTU2_2	MTU2_2	MTU2_2	MTU2_2	MTU2_2	MTU2_2	
	MTU2_3	MTU2_3	MTU2_3	MTU2_3	MTU2_3	MTU2_3	MTU2_3	MTU2_3	
IPRF	MTU2_4	MTU2_4	MTU2_4	MTU2_4	MTU2_4	MTU2_4	MTU2_4	MTU2_4	
	MTU2_5	MTU2_5	MTU2_5	MTU2_5	POE(MTU2)	POE(MTU2)	POE(MTU2)	POE(MTU2)	
IPRH	—	—	—	—	—	—	—	—	
	—	—	—	—	—	—	—	—	
IPRI	—	—	—	—	—	—	—	—	
	—	—	—	—	—	—	—	—	
IPRJ	CMT_0	CMT_0	CMT_0	CMT_0	CMT_1	CMT_1	CMT_1	CMT_1	
	—	—	—	—	WDT	WDT	WDT	WDT	
IPRK	A/D_0.1	A/D_0.1	A/D_0.1	A/D_0.1	—	—	—	—	
	—	—	—	—	—	—	—	—	
IPRL	SCI_0	SCI_0	SCI_0	SCI_0	SCI_1	SCI_1	SCI_1	SCI_1	
	SCI_2	SCI_2	SCI_2	SCI_2	—	—	—	—	
IPRM	—	—	—	—	—	—	—	—	
	—	—	—	—	—	—	—	—	
BARA	BAA31	BAA30	BAA29	BAA28	BAA27	BAA26	BAA25	BAA24	UBC
	BAA23	BAA22	BAA21	BAA20	BAA19	BAA18	BAA17	BAA16	
	BAA15	BAA14	BAA13	BAA12	BAA11	BAA10	BAA9	BAA8	
	BAA7	BAA6	BAA5	BAA4	BAA3	BAA2	BAA1	BAA0	
BAMRA	BAMA31	BAMA30	BAMA29	BAMA28	BAMA27	BAMA26	BAMA25	BAMA24	
	BAMA23	BAMA22	BAMA21	BAMA20	BAMA19	BAMA18	BAMA17	BAMA16	
	BAMA15	BAMA14	BAMA13	BAMA12	BAMA11	BAMA10	BAMA9	BAMA8	
	BAMA7	BAMA6	BAMA5	BAMA4	BAMA3	BAMA2	BAMA1	BAMA0	
BBRA	—	—	—	—	—	CPA[2:0]			
	CDA[1:0]		IDA[1:0]		RWA[1:0]		SZA[1:0]		

Register Abbreviation	Bit 31/23/15/7	Bit 30/22/14/6	Bit 29/21/13/5	Bit 28/20/12/4	Bit 27/19/11/3	Bit 26/18/10/2	Bit 25/17/9/1	Bit 24/16/8/0	Module
BDRA	BDA31	BDA30	BDA29	BDA28	BDA27	BDA26	BDA25	BDA24	UBC
	BDA23	BDA22	BDA21	BDA20	BDA19	BDA18	BDA17	BDA16	
	BDA15	BDA14	BDA13	BDA12	BDA11	BDA10	BDA9	BDA8	
	BDA7	BDA6	BDA5	BDA4	BDA3	BDA2	BDA1	BDA0	
BDMRA	BDMA31	BDMA30	BDMA29	BDMA28	BDMA27	BDMA26	BDMA25	BDMA24	UBC
	BDMA23	BDMA22	BDMA21	BDMA20	BDMA19	BDMA18	BDMA17	BDMA16	
	BDMA15	BDMA14	BDMA13	BDMA12	BDMA11	BDMA10	BDMA9	BDMA8	
	BDMA7	BDMA6	BDMA5	BDMA4	BDMA3	BDMA2	BDMA1	BDMA0	
BARB	BAB31	BAB30	BAB29	BAB28	BAB27	BAB26	BAB25	BAB24	UBC
	BAB23	BAB22	BAB21	BAB20	BAB19	BAB18	BAB17	BAB16	
	BAB15	BAB14	BAB13	BAB12	BAB11	BAB10	BAB9	BAB8	
	BAB7	BAB6	BAB5	BAB4	BAB3	BAB2	BAB1	BAB0	
BAMRB	BAMB31	BAMB30	BAMB29	BAMB28	BAMB27	BAMB26	BAMB25	BAMB24	UBC
	BAMB23	BAMB22	BAMB21	BAMB20	BAMB19	BAMB18	BAMB17	BAMB16	
	BAMB15	BAMB14	BAMB13	BAMB12	BAMB11	BAMB10	BAMB9	BAMB8	
	BAMB7	BAMB6	BAMB5	BAMB4	BAMB3	BAMB2	BAMB1	BAMB0	
BBRB	—	—	—	—	—	CPB[2:0]			UBC
	CDB[1:0]		IDB[1:0]		RWB[1:0]		SZB[1:0]		
BDRB	BDB31	BDB30	BDB29	BDB28	BDB27	BDB26	BDB25	BDB24	UBC
	BDB23	BDB22	BDB21	BDB20	BDB19	BDB18	BDB17	BDB16	
	BDB15	BDB14	BDB13	BDB12	BDB11	BDB10	BDB9	BDB8	
	BDB7	BDB6	BDB5	BDB4	BDB3	BDB2	BDB1	BDB0	
BDMRB	BDMB31	BDMB30	BDMB29	BDMB28	BDMB27	BDMB26	BDMB25	BDMB24	UBC
	BDMB23	BDMB22	BDMB21	BDMB20	BDMB19	BDMB18	BDMB17	BDMB16	
	BDMB15	BDMB14	BDMB13	BDMB12	BDMB11	BDMB10	BDMB9	BDMB8	
	BDMB7	BDMB6	BDMB5	BDMB4	BDMB3	BDMB2	BDMB1	BDMB0	
BRCR	—	—	—	—	—	—	—	—	UBC
	—	—	—	—	UBIDB	—	UBIDA	—	
	SCMFCA	SCMFCB	SCMFDA	SCMFDB	PCTE	PCBA	—	—	
	DBEA	PCBB	DBEB	—	SEQ	—	—	ETBE	

Register Abbreviation	Bit 31/23/15/7	Bit 30/22/14/6	Bit 29/21/13/5	Bit 28/20/12/4	Bit 27/19/11/3	Bit 26/18/10/2	Bit 25/17/9/1	Bit 24/16/8/0	Module
BRSR	SVF	—	—	—	BSA27	BSA26	BSA25	BSA24	UBC
	BSA23	BSA22	BSA21	BSA20	BSA19	BSA18	BSA17	BSA16	
	BSA15	BSA14	BSA13	BSA12	BSA11	BSA10	BSA9	BSA8	
	BSA7	BSA6	BSA5	BSA4	BSA3	BSA2	BSA1	BSA0	
BRDR	DVF	—	—	—	BDA27	BDA26	BDA25	BDA24	
	BDA23	BDA22	BDA21	BDA20	BDA19	BDA18	BDA17	BDA16	
	BDA15	BDA14	BDA13	BDA12	BDA11	BDA10	BDA9	BDA8	
	BDA7	BDA6	BDA5	BDA4	BDA3	BDA2	BDA1	BDA0	
BETR	—	—	—	—	BET[11:8]				
	BET[7:0]								

## 20.3 Register States in Each Operating Mode

Register Abbreviation	Power-on reset	Manual reset	Software Standby	Module Standby	Sleep	Module	
SCSMR_0	Initialized	Retained	Initialized	Initialized	Retained	SCI (Channel 0)	
SCBRR_0	Initialized	Retained	Initialized	Initialized	Retained		
SCSCR_0	Initialized	Retained	Initialized	Initialized	Retained		
SCTDR_0	Initialized	Retained	Initialized	Initialized	Retained		
SCSSR_0	Initialized	Retained	Initialized	Initialized	Retained		
SCRDR_0	Initialized	Retained	Initialized	Initialized	Retained		
SCSDCR_0	Initialized	Retained	Initialized	Initialized	Retained		
SCSPTR_0	Initialized	Retained	Initialized	Initialized	Retained		
SCSMR_1	Initialized	Retained	Initialized	Initialized	Retained		SCI (Channel 1)
SCBRR_1	Initialized	Retained	Initialized	Initialized	Retained		
SCSCR_1	Initialized	Retained	Initialized	Initialized	Retained		
SCTDR_1	Initialized	Retained	Initialized	Initialized	Retained		
SCSSR_1	Initialized	Retained	Initialized	Initialized	Retained		
SCRDR_1	Initialized	Retained	Initialized	Initialized	Retained		
SCSDCR_1	Initialized	Retained	Initialized	Initialized	Retained		
SCSPTR_1	Initialized	Retained	Initialized	Initialized	Retained		
SCSMR_2	Initialized	Retained	Initialized	Initialized	Retained	SCI (Channel 2)	
SCBRR_2	Initialized	Retained	Initialized	Initialized	Retained		
SCSCR_2	Initialized	Retained	Initialized	Initialized	Retained		
SCTDR_2	Initialized	Retained	Initialized	Initialized	Retained		
SCSSR_2	Initialized	Retained	Initialized	Initialized	Retained		
SCRDR_2	Initialized	Retained	Initialized	Initialized	Retained		
SCSDCR_2	Initialized	Retained	Initialized	Initialized	Retained		
SCSPTR_2	Initialized	Retained	Initialized	Initialized	Retained		
TCR_3	Initialized	Retained	Initialized	Initialized	Retained		MTU2
TCR_4	Initialized	Retained	Initialized	Initialized	Retained		
TMDR_3	Initialized	Retained	Initialized	Initialized	Retained		
TMDR_4	Initialized	Retained	Initialized	Initialized	Retained		
TIORH_3	Initialized	Retained	Initialized	Initialized	Retained		

Register Abbreviation	Power-on reset	Manual reset	Software Standby	Module Standby	Sleep	Module
TIORL_3	Initialized	Retained	Initialized	Initialized	Retained	MTU2
TIORH_4	Initialized	Retained	Initialized	Initialized	Retained	
TIORL_4	Initialized	Retained	Initialized	Initialized	Retained	
TIER_3	Initialized	Retained	Initialized	Initialized	Retained	
TIER_4	Initialized	Retained	Initialized	Initialized	Retained	
TOER	Initialized	Retained	Initialized	Initialized	Retained	
TGCR	Initialized	Retained	Initialized	Initialized	Retained	
TOCR1	Initialized	Retained	Initialized	Initialized	Retained	
TOCR2	Initialized	Retained	Initialized	Initialized	Retained	
TCNT_3	Initialized	Retained	Initialized	Initialized	Retained	
TCNT_4	Initialized	Retained	Initialized	Initialized	Retained	
TCDR	Initialized	Retained	Initialized	Initialized	Retained	
TDDR	Initialized	Retained	Initialized	Initialized	Retained	
TGRA_3	Initialized	Retained	Initialized	Initialized	Retained	
TGRB_3	Initialized	Retained	Initialized	Initialized	Retained	
TGRA_4	Initialized	Retained	Initialized	Initialized	Retained	
TGRB_4	Initialized	Retained	Initialized	Initialized	Retained	
TCNTS	Initialized	Retained	Initialized	Initialized	Retained	
TCBR	Initialized	Retained	Initialized	Initialized	Retained	
TGRC_3	Initialized	Retained	Initialized	Initialized	Retained	
TGRD_3	Initialized	Retained	Initialized	Initialized	Retained	
TGRC_4	Initialized	Retained	Initialized	Initialized	Retained	
TGRD_4	Initialized	Retained	Initialized	Initialized	Retained	
TSR_3	Initialized	Retained	Initialized	Initialized	Retained	
TSR_4	Initialized	Retained	Initialized	Initialized	Retained	
TITCR	Initialized	Retained	Initialized	Initialized	Retained	
TITCNT	Initialized	Retained	Initialized	Initialized	Retained	
TBTER	Initialized	Retained	Initialized	Initialized	Retained	
TDER	Initialized	Retained	Initialized	Initialized	Retained	
TOLBR	Initialized	Retained	Initialized	Initialized	Retained	
TBTM_3	Initialized	Retained	Initialized	Initialized	Retained	

## Section 20 List of Registers

Register Abbreviation	Power-on reset	Manual reset	Software Standby	Module Standby	Sleep	Module
TBTM_4	Initialized	Retained	Initialized	Initialized	Retained	MTU2
TADCR	Initialized	Retained	Initialized	Initialized	Retained	
TADCORA_4	Initialized	Retained	Initialized	Initialized	Retained	
TADCORB_4	Initialized	Retained	Initialized	Initialized	Retained	
TADCOBRA_4	Initialized	Retained	Initialized	Initialized	Retained	
TADCOBRB_4	Initialized	Retained	Initialized	Initialized	Retained	
TWCR	Initialized	Retained	Initialized	Initialized	Retained	
TSTR	Initialized	Retained	Initialized	Initialized	Retained	
TSYR	Initialized	Retained	Initialized	Initialized	Retained	
TRWER	Initialized	Retained	Initialized	Initialized	Retained	
TCR_0	Initialized	Retained	Initialized	Initialized	Retained	
TMDR_0	Initialized	Retained	Initialized	Initialized	Retained	
TIORH_0	Initialized	Retained	Initialized	Initialized	Retained	
TIORL_0	Initialized	Retained	Initialized	Initialized	Retained	
TIER_0	Initialized	Retained	Initialized	Initialized	Retained	
TSR_0	Initialized	Retained	Initialized	Initialized	Retained	
TCNT_0	Initialized	Retained	Initialized	Initialized	Retained	
TGRA_0	Initialized	Retained	Initialized	Initialized	Retained	
TGRB_0	Initialized	Retained	Initialized	Initialized	Retained	
TGRC_0	Initialized	Retained	Initialized	Initialized	Retained	
TGRD_0	Initialized	Retained	Initialized	Initialized	Retained	
TGRE_0	Initialized	Retained	Initialized	Initialized	Retained	
TGRF_0	Initialized	Retained	Initialized	Initialized	Retained	
TIER2_0	Initialized	Retained	Initialized	Initialized	Retained	
TSR2_0	Initialized	Retained	Initialized	Initialized	Retained	
TBTM_0	Initialized	Retained	Initialized	Initialized	Retained	
TCR_1	Initialized	Retained	Initialized	Initialized	Retained	
TMDR_1	Initialized	Retained	Initialized	Initialized	Retained	
TIOR_1	Initialized	Retained	Initialized	Initialized	Retained	
TIER_1	Initialized	Retained	Initialized	Initialized	Retained	



Register Abbreviation	Power-on reset	Manual reset	Software Standby	Module Standby	Sleep	Module
TSR_1	Initialized	Retained	Initialized	Initialized	Retained	MTU2
TCNT_1	Initialized	Retained	Initialized	Initialized	Retained	
TGRA_1	Initialized	Retained	Initialized	Initialized	Retained	
TGRB_1	Initialized	Retained	Initialized	Initialized	Retained	
TICCR	Initialized	Retained	Initialized	Initialized	Retained	
TCR_2	Initialized	Retained	Initialized	Initialized	Retained	
TMDR_2	Initialized	Retained	Initialized	Initialized	Retained	
TIOR_2	Initialized	Retained	Initialized	Initialized	Retained	
TIER_2	Initialized	Retained	Initialized	Initialized	Retained	
TSR_2	Initialized	Retained	Initialized	Initialized	Retained	
TCNT_2	Initialized	Retained	Initialized	Initialized	Retained	
TGRA_2	Initialized	Retained	Initialized	Initialized	Retained	
TGRB_2	Initialized	Retained	Initialized	Initialized	Retained	
TCNTU_5	Initialized	Retained	Initialized	Initialized	Retained	
TGRU_5	Initialized	Retained	Initialized	Initialized	Retained	
TCRU_5	Initialized	Retained	Initialized	Initialized	Retained	
TIORU_5	Initialized	Retained	Initialized	Initialized	Retained	
TCNTV_5	Initialized	Retained	Initialized	Initialized	Retained	
TGRV_5	Initialized	Retained	Initialized	Initialized	Retained	
TCRV_5	Initialized	Retained	Initialized	Initialized	Retained	
TIORV_5	Initialized	Retained	Initialized	Initialized	Retained	
TCNTW_5	Initialized	Retained	Initialized	Initialized	Retained	
TGRW_5	Initialized	Retained	Initialized	Initialized	Retained	
TCRW_5	Initialized	Retained	Initialized	Initialized	Retained	
TIORW_5	Initialized	Retained	Initialized	Initialized	Retained	
TSR_5	Initialized	Retained	Initialized	Initialized	Retained	
TIER_5	Initialized	Retained	Initialized	Initialized	Retained	
TSTR5	Initialized	Retained	Initialized	Initialized	Retained	
TCNTCMPCLR	Initialized	Retained	Initialized	Initialized	Retained	

## Section 20 List of Registers

Register Abbreviation	Power-on reset	Manual reset	Software Standby	Module Standby	Sleep	Module
ADDR0	Initialized	Retained	Initialized	Initialized	Retained	A/D (Channel 0)
ADDR1	Initialized	Retained	Initialized	Initialized	Retained	
ADDR2	Initialized	Retained	Initialized	Initialized	Retained	
ADDR3	Initialized	Retained	Initialized	Initialized	Retained	
ADCSR_0	Initialized	Retained	Initialized	Initialized	Retained	
ADCR_0	Initialized	Retained	Initialized	Initialized	Retained	
ADDR4	Initialized	Retained	Initialized	Initialized	Retained	A/D (Channel 1)
ADDR5	Initialized	Retained	Initialized	Initialized	Retained	
ADDR6	Initialized	Retained	Initialized	Initialized	Retained	
ADDR7	Initialized	Retained	Initialized	Initialized	Retained	
ADCSR_1	Initialized	Retained	Initialized	Initialized	Retained	
ADCR_1	Initialized	Retained	Initialized	Initialized	Retained	
FCCS	Initialized	Retained	Initialized	Initialized	Retained	FLASH
FPCS	Initialized	Retained	Initialized	Initialized	Retained	
FECS	Initialized	Retained	Initialized	Initialized	Retained	
FKEY	Initialized	Retained	Initialized	Initialized	Retained	
FTDAR	Initialized	Retained	Initialized	Initialized	Retained	
CMSTR	Initialized	Retained	Initialized	Initialized	Retained	CMT
CMCSR_0	Initialized	Retained	Initialized	Initialized	Retained	
CMCNT_0	Initialized	Retained	Initialized	Initialized	Retained	
CMCOR_0	Initialized	Retained	Initialized	Initialized	Retained	
CMCSR_1	Initialized	Retained	Initialized	Initialized	Retained	
CMCNT_1	Initialized	Retained	Initialized	Initialized	Retained	
CMCOR_1	Initialized	Retained	Initialized	Initialized	Retained	
ICSR1	Initialized	Retained	Retained	—	Retained	POE
OCSR1	Initialized	Retained	Retained	—	Retained	
ICSR3	Initialized	Retained	Retained	—	Retained	
SPOER	Initialized	Retained	Retained	—	Retained	
POECR1	Initialized	Retained	Retained	—	Retained	
POECR2	Initialized	Retained	Retained	—	Retained	

Register Abbreviation	Power-on reset	Manual reset	Software Standby	Module Standby	Sleep	Module
PADRL	Initialized	Retained	Retained	—	Retained	I/O
PAIORL	Initialized	Retained	Retained	—	Retained	PFC
PACRL4	Initialized	Retained	Retained	—	Retained	
PACRL3	Initialized	Retained	Retained	—	Retained	
PACRL2	Initialized	Retained	Retained	—	Retained	
PACRL1	Initialized	Retained	Retained	—	Retained	
PAPRL	Initialized	Retained	Retained	—	Retained	I/O
PBDRH	Initialized	Retained	Retained	—	Retained	PFC
PBDRL	Initialized	Retained	Retained	—	Retained	
PBIORH	Initialized	Retained	Retained	—	Retained	
PBIORL	Initialized	Retained	Retained	—	Retained	
PBCRH1	Initialized	Retained	Retained	—	Retained	
PBCRL2	Initialized	Retained	Retained	—	Retained	I/O
PBCRL1	Initialized	Retained	Retained	—	Retained	
PBPRH	Initialized	Retained	Retained	—	Retained	
PBPRL	Initialized	Retained	Retained	—	Retained	
PEDRL	Initialized	Retained	Retained	—	Retained	
PEIORL	Initialized	Retained	Retained	—	Retained	PFC
PECRL4	Initialized	Retained	Retained	—	Retained	
PECRL3	Initialized	Retained	Retained	—	Retained	
PECRL2	Initialized	Retained	Retained	—	Retained	
PECRL1	Initialized	Retained	Retained	—	Retained	
PEPRL	Initialized	Retained	Retained	—	Retained	I/O
IFCR	Initialized	Retained	Retained	—	Retained	PFC
PFDRL	Initialized	Retained	Retained	—	Retained	I/O
FRQCR	Initialized <sup>*1</sup>	Retained	Retained	—	Retained	CPG
STBCR1	Initialized	Retained	Retained	—	Retained	Power-down modes
STBCR2	Initialized	Retained	Retained	—	Retained	
STBCR3	Initialized	Retained	Retained	—	Retained	
STBCR4	Initialized	Retained	Retained	—	Retained	

## Section 20 List of Registers

Register Abbreviation	Power-on reset	Manual reset	Software Standby	Module Standby	Sleep	Module	
STBCR5	Initialized	Retained	Retained	—	Retained	Power-down modes	
STBCR6	Initialized	Retained	Retained	—	Retained		
WTCNT	Initialized* <sup>1</sup>	Retained	Retained	—	Retained	WDT	
WTCSR	Initialized* <sup>1</sup>	Retained	Retained	—	Retained		
OSCCR	Initialized* <sup>2</sup>	Retained	Retained* <sup>3</sup>	—	Retained	CPG	
RAMCR	Initialized	Retained	Retained	—	Retained	Power-down modes	
ADTSR_0	Initialized	Retained	Retained	Retained	Retained	A/D	
ICR0	Initialized	Initialized	Retained	—	Retained	INTC	
IRQCR	Initialized	Initialized	Retained	—	Retained		
IRQSR	Initialized	Initialized	Retained	—	Retained		
IPRA	Initialized	Initialized	Retained	—	Retained		
IPRB	Initialized	Initialized	Retained	—	Retained		
IPRC	Initialized	Initialized	Retained	—	Retained		
IPRD	Initialized	Initialized	Retained	—	Retained		
IPRE	Initialized	Initialized	Retained	—	Retained		
IPRF	Initialized	Initialized	Retained	—	Retained		
IPRH	Initialized	Initialized	Retained	—	Retained		
IPRI	Initialized	Initialized	Retained	—	Retained		
IPRJ	Initialized	Initialized	Retained	—	Retained		
IPRK	Initialized	Initialized	Retained	—	Retained		
IPRL	Initialized	Initialized	Retained	—	Retained		
IPRM	Initialized	Initialized	Retained	—	Retained		
BARA	Initialized	Retained	Retained	Initialized	Retained		UBC
BAMRA	Initialized	Retained	Retained	Initialized	Retained		
BBRA	Initialized	Retained	Retained	Initialized	Retained		
BDRA	Initialized	Retained	Retained	Initialized	Retained		
BDMRA	Initialized	Retained	Retained	Initialized	Retained		
BARB	Initialized	Retained	Retained	Initialized	Retained		
BAMRB	Initialized	Retained	Retained	Initialized	Retained		
BBRB	Initialized	Retained	Retained	Initialized	Retained		

Register Abbreviation	Power-on reset	Manual reset	Software Standby	Module Standby	Sleep	Module
BDRB	Initialized	Retained	Retained	Initialized	Retained	UBC
BDMRB	Initialized	Retained	Retained	Initialized	Retained	
BRCR	Initialized	Retained	Retained	Initialized	Retained	
BRSR	Initialized	Retained	Retained	Initialized	Retained	
BRDR	Initialized	Retained	Retained	Initialized	Retained	
BETR	Initialized	Retained	Retained	Initialized	Retained	

- Notes:
1. Not initialized by a WDT power-on reset.
  2. The OSCSTOP bit is not initialized by a WDT power-on reset.
  3. The OSCSTOP bit is initialized.



## Section 21 Electrical Characteristics

All values for electrical characteristics are preliminary, and are subject to change without notice as a result of characteristics evaluation.

### 21.1 Absolute Maximum Ratings

Table 21.1 lists the absolute maximum ratings.

**Table 21.1 Absolute Maximum Ratings**

Item	Symbol	Value	Unit	
Power supply voltage	$V_{CC}$	-0.3 to + 7.0	V	
Input voltage (except analog input)	$V_{in}$	-0.3 to $V_{CC} + 0.3$	V	
Analog power supply voltage	$AV_{CC}$	-0.3 to + 7.0	V	
Analog input voltage	$V_{an}$	-0.3 to $AV_{CC} + 0.3$	V	
Operating temperature	Consumer specifications	$T_{opr}$	-20 to + 85	°C
		Industrial specifications	-40 to + 85	°C
Storage temperature	$T_{stg}$	-55 to + 125	°C	

[Operating Precautions]

Operating the LSI in excess of the absolute maximum ratings may result in permanent damage.

## 21.2 DC Characteristics

Tables 21.2 and 21.3 list DC characteristics.

**Table 21.2 DC Characteristics**

Conditions:  $V_{CC} = AV_{CC} = 4.0\text{ V to }5.5\text{ V}$ ,  $V_{SS} = PLLV_{SS} = AV_{SS} = 0\text{ V}$ ,  
 $T_a = -20\text{ to }+85^\circ\text{C}$  (consumer specifications),  
 $T_a = -40\text{ to }+85^\circ\text{C}$  (industrial specifications)

Item	Symbol	Min.	Typ.	Max.	Unit	Test Conditions
Input high-level voltage (other than Schmitt trigger input voltage)	RES, $\overline{MRES}$ , NMI, FWE, MD1, $\overline{ASEMD0}$ , EXTAL	$V_{IH}$	$V_{CC} - 0.7$	—	$V_{CC} + 0.3$	V
	Analog ports	2.2	—	$AV_{CC} + 0.3$	V	
	Other input pins	2.2	—	$V_{CC} + 0.3$	V	
Input low-level voltage (other than Schmitt trigger input voltage)	$\overline{RES}$ , $\overline{MRES}$ , NMI, FWE, MD1, $\overline{ASEMD0}$ , EXTAL	$V_{IL}$	-0.3	—	0.5	V
	Other input pins	-0.3	—	0.8	V	
Schmitt trigger input voltage	IRQ3 to IRQ0, POE8, POE3, POE1, POE0,	$V_{T+}$	$V_{CC} - 0.5$	—	—	V
		$V_{T-}$	—	—	1.0	V
	TCLKA to TCLKD, TIOC0A to TIOC0D, TIOC1A, TIOC1B, TIOC2A, TIOC2B, TIOC3A to TIOC3D, TIOC4A to TIOC4D, TIC5U, TIC5V, TIC5WS, SCK0 to SCK3, RXD0 to RXD3	$V_{T+} - V_{T-}$	0.4	—	—	V
Input leak current	All input pins (except $\overline{ASEMD0}$ )	$ I_{in} $	—	—	1.0	$\mu\text{A}$
Input pull-up MOS current	$\overline{ASEMD0}$ , POE3	$-I_{pu}$	—	—	800	$\mu\text{A}$ $V_{in} = 0\text{ V}$
Tri-state leakage current (OFF state)	Ports A, B, E	$ I_{tsl} $	—	—	1.0	$\mu\text{A}$



Item		Symbol	Min.	Typ.	Max.	Unit	Test Conditions
Output high voltage	TIOC3B, TIOC3D, TIOC4A to TIOC4D	$V_{OH}$	$V_{CC} - 0.8$	—	—	V	$I_{OH} = -5$ mA, $V_{CC} = 4.5$ V to 5.5 V
	$\overline{WDTOVF}$		$V_{CC} - 0.5$	—	—	V	$I_{OH} = -100$ $\mu$ A
	All other output pins		$V_{CC} - 0.5$	—	—	V	$I_{OH} = -200$ $\mu$ A
			$V_{CC} - 1.0$	—	—	V	$I_{OH} = -1$ mA
			$V_{CC} - 1.5$	—	—	V	$I_{OH} = -2$ mA (reference values)
Output low voltage	TIOC3B, TIOC3D, TIOC4A to TIOC4D	$V_{OL}$	—	—	1.0	V	$I_{OL} = 15$ mA, $V_{CC} = 4.5$ V to 5.5 V
			—	—	0.6	V	$I_{OL} = 10$ mA, $V_{CC} = 4.5$ V to 5.5 V
			—	—	0.44	V	$I_{OL} = 8$ mA, $V_{CC} = 4.5$ V to 5.5 V
	All other output pins		—	—	0.4	V	$I_{OL} = 1.6$ mA
Input capacitance	All input pins	$C_{in}$	—	—	20	pF	$V_{in} = 0$ V $f = 1$ MHz $T_a = 25^\circ\text{C}$
Supply current	Normal operation	$I_{CC}$	—	52	70	mA	$f\phi = 50$ MHz
	Sleep		—	33	50	mA	$f\phi = 50$ MHz
	Software standby		—	—	5	mA	$T_a \leq 50^\circ\text{C}$
			—	—	15	mA	$50^\circ\text{C} < T_a$
Analog power supply current	During A/D conversion	$AI_{CC}$	—	3	5	mA	The value per module
	Waiting for A/D conversion		—	—	2	mA	The value per module
	Standby		—	—	15	$\mu$ A	

## [Operating Precautions]

1. When the A/D converter is not used, do not leave the  $AV_{CC}$  and  $AV_{SS}$  pins open.
2. The supply current was measured when  $V_{IH}$  (Min.) =  $V_{CC} - 0.5$  V,  $V_{IL}$  (Max.) = 0.5 V, with all output pins unloaded.

**Table 21.3 Permitted Output Current Values**

Conditions:  $V_{CC} = AV_{CC} = 4.0 \text{ V to } 5.5 \text{ V}$ ,  $V_{SS} = PLLV_{SS} = AV_{SS} = 0 \text{ V}$ ,  
 $T_a = -20 \text{ to } +85^\circ\text{C}$  (consumer specifications),  
 $T_a = -40 \text{ to } +85^\circ\text{C}$  (industrial specifications)

Item	Symbol	Min.	Typ.	Max.	Unit
Permissible current in low-level output (per pin)	$I_{OL}$	—	—	2.0*	mA
Permissible current in low-level output (total)	$\Sigma I_{OL}$	—	—	80	mA
Permissible current in high-level output (per pin)	$-I_{OH}$	—	—	2.0*	mA
Permissible current in high-level output (total)	$\Sigma -I_{OH}$	—	—	25	mA

[Operating Precautions]

To assure LSI reliability, do not exceed the output values listed in table 21.3.

Note: \*  $I_{OL} = 15 \text{ mA (Max.)}/-I_{OH} = 5 \text{ mA (Max.)}$  for pins PE9 and PE11 to PE15. However, at least three pins are permitted to have simultaneously  $I_{OL}/-I_{OH} > 2.0 \text{ mA}$  among these pins.

## 21.3 AC Characteristics

Signals input to this LSI are basically handled as signals in synchronization with a clock. The setup and hold times for input pins must be followed.

**Table 21.4 Maximum Operating Frequency**

Conditions:  $V_{CC} = AV_{CC} = 4.0\text{ V to }5.5\text{ V}$ ,  $V_{SS} = PLLV_{SS} = AV_{SS} = 0\text{ V}$ ,  
 $T_a = -20\text{ to }+85^\circ\text{C}$  (consumer specifications),  
 $T_a = -40\text{ to }+85^\circ\text{C}$  (industrial specifications)

Item		Symbol	Min.	Typ.	Max.	Unit	Remarks
Operating frequency	CPU ( $I\phi$ )	f	10	—	50	MHz	—
	Peripheral module ( $P\phi$ )		10	—	40		

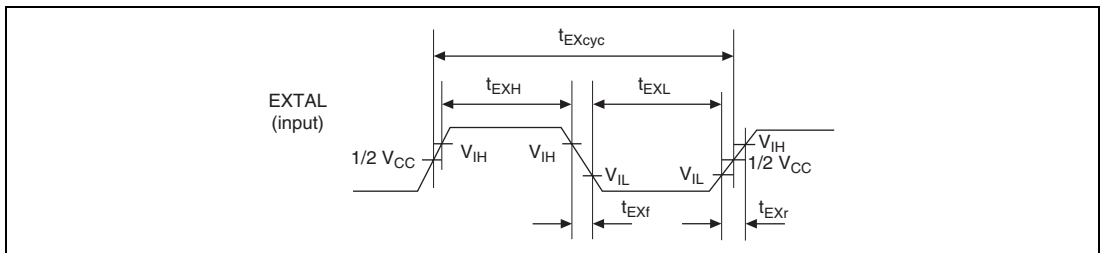
### 21.3.1 Clock Timing

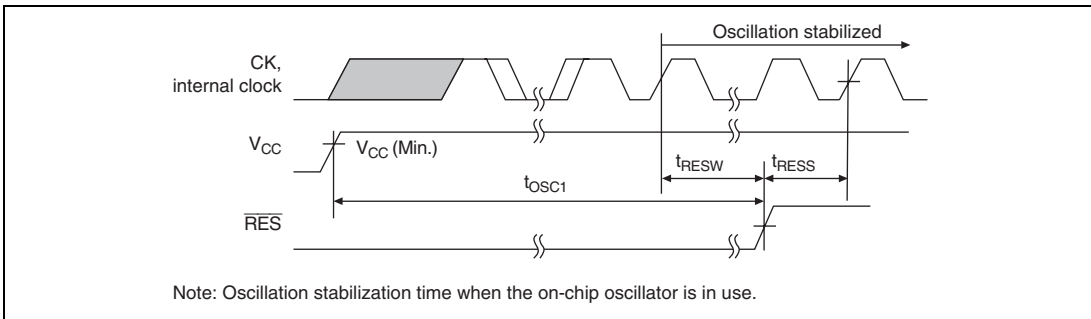
**Table 21.5 Clock Timing**

Conditions:  $V_{CC} = AV_{CC} = 4.0\text{ V to }5.5\text{ V}$ ,  $V_{SS} = PLLV_{SS} = AV_{SS} = 0\text{ V}$ ,  
 $T_a = -20\text{ to }+85^\circ\text{C}$  (consumer specifications),  
 $T_a = -40\text{ to }+85^\circ\text{C}$  (industrial specifications)

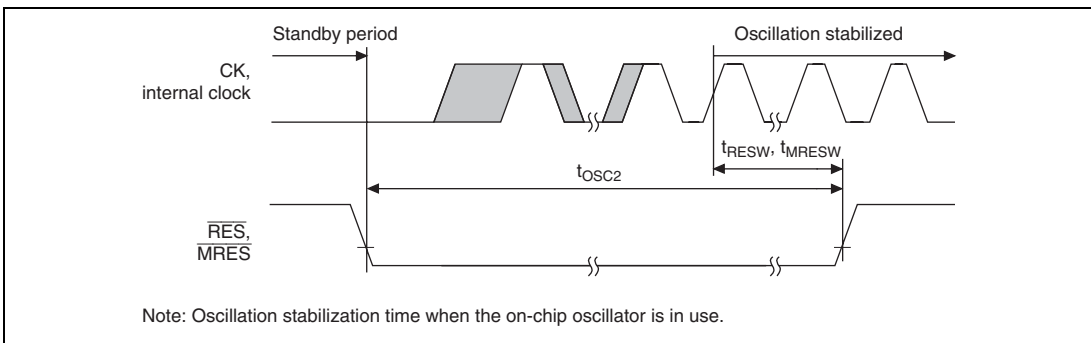
Item	Symbol	Min.	Max.	Unit	Reference Figure
EXTAL clock input frequency	$f_{EX}$	10	12.5	MHz	Figure 21.1
EXTAL clock input cycle time	$t_{EXcyc}$	80	100	ns	
EXTAL clock input low pulse width	$t_{EXL}$	20	—	ns	
EXTAL clock input high pulse width	$t_{EXH}$	20	—	ns	
EXTAL clock input rising time	$t_{EXr}$	—	5	ns	
EXTAL clock input falling time	$t_{EXf}$	—	5	ns	
CK (B $\phi$ ) clock frequency (reference values)	$f_{OP}$	10	40	MHz	*
CK (B $\phi$ ) clock cycle time (reference values)	$t_{cyc}$	25	100	ns	
Power-on oscillation stabilization time	$t_{OSC1}$	10	—	ms	Figure 21.2
Oscillation stabilization time on return from standby 1	$t_{OSC2}$	10	—	ms	Figure 21.3
Oscillation stabilization time on return from standby 2	$t_{OSC3}$	10	—	ms	Figure 21.4

Note: \* Depends on the frequency control register (FRQCR).

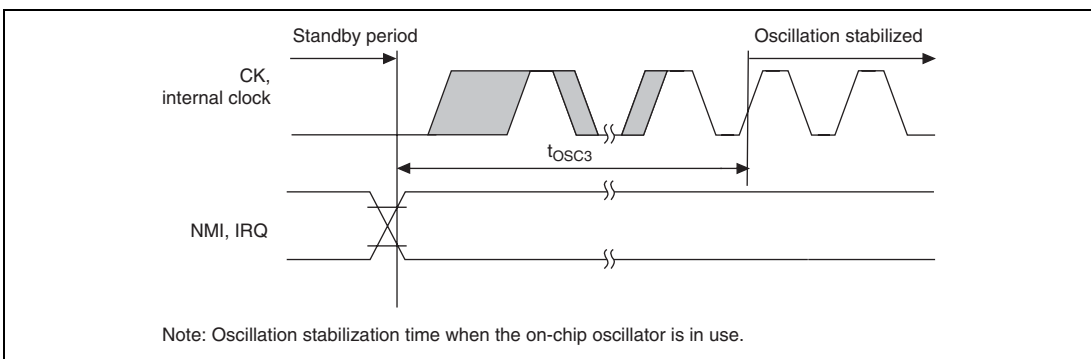

**Figure 21.1 Timing of EXTAL Input Clock Signal**



**Figure 21.2 Power-On Oscillation Stabilization Time**



**Figure 21.3 Oscillation Stabilization Time on Return from Standby (Return by Reset)**



**Figure 21.4 Oscillation Stabilization Time on Return from Standby (Return by NMI or IRQ)**

### 21.3.2 Control Signal Timing

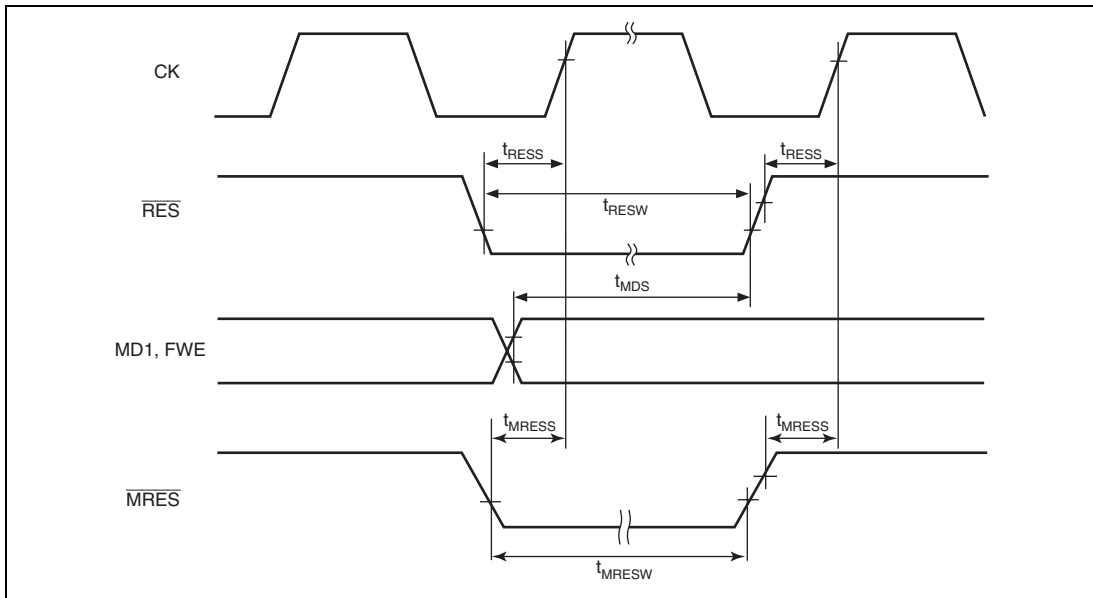
**Table 21.6 Control Signal Timing**

Conditions:  $V_{CC} = AV_{CC} = 4.0\text{ V to }5.5\text{ V}$ ,  $V_{SS} = PLLV_{SS} = AV_{SS} = 0\text{ V}$ ,  
 $T_a = -20\text{ to }+85^\circ\text{C}$  (consumer specifications),  
 $T_a = -40\text{ to }+85^\circ\text{C}$  (industrial specifications)

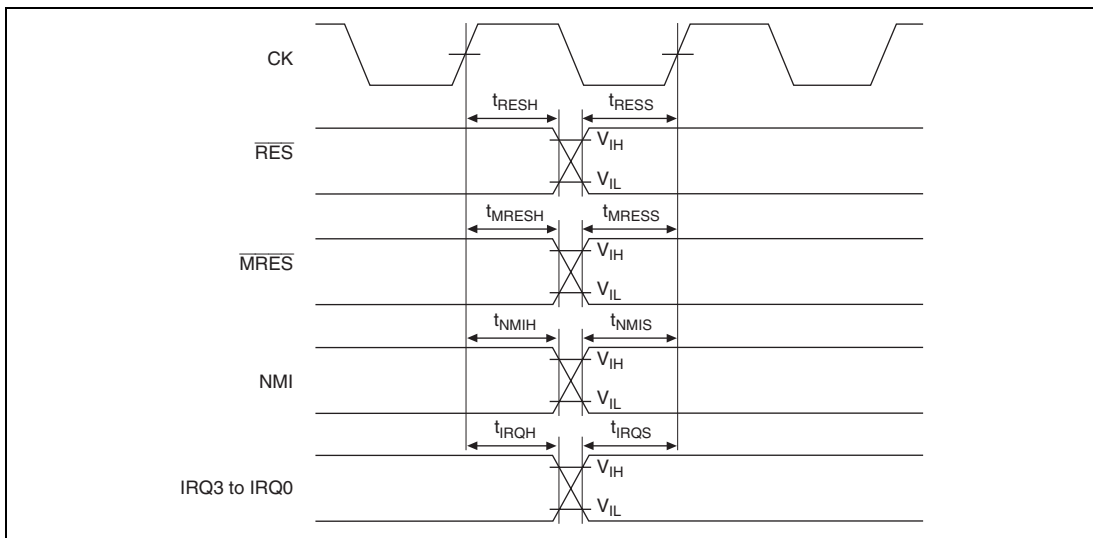
Item	Symbol	Min.	Max.	Unit	Reference Figure
$\overline{\text{RES}}$ pulse width	$t_{\text{RESW}}$	20* <sup>2</sup>	—	$t_{\text{Bcyc}}$ * <sup>4</sup>	Figures 21.2, 21.3, 21.5, 21.6
$\overline{\text{RES}}$ setup time* <sup>1</sup> (reference values)	$t_{\text{RESS}}$	65	—	ns	
$\overline{\text{RES}}$ hold time (reference values)	$t_{\text{RESH}}$	15	—	ns	
$\overline{\text{MRES}}$ pulse width	$t_{\text{MRESW}}$	20* <sup>3</sup>	—	$t_{\text{Bcyc}}$ * <sup>4</sup>	
$\overline{\text{MRES}}$ setup time* <sup>1</sup> (reference values)	$t_{\text{MRESS}}$	25	—	ns	
$\overline{\text{MRES}}$ hold time (reference values)	$t_{\text{MRESH}}$	15	—	ns	
MD1, FWE setup time	$t_{\text{MDS}}$	20	—	$t_{\text{Bcyc}}$ * <sup>4</sup>	Figure 21.5
NMI setup time* <sup>1</sup> (reference values)	$t_{\text{NMIS}}$	60	—	ns	Figure 21.6
NMI hold time (reference values)	$t_{\text{NMIH}}$	10	—	ns	
IRQ3 to IRQ0 setup time* <sup>1</sup> (reference values)	$t_{\text{IRQS}}$	35	—	ns	
IRQ3 to IRQ0 hold time (reference values)	$t_{\text{IRQH}}$	35	—	ns	
IRQOUT output delay time (reference values)	$t_{\text{IROOD}}$	—	100	ns	Figure 21.7

Notes: 1. The  $\overline{\text{RES}}$ ,  $\overline{\text{MRES}}$ , NMI, and IRQ3 to IRQ0 signals are asynchronous signals. When the setup time is satisfied, change of signal level is detected at the rising edge of the clock. If not, the detection is delayed until the rising edge of the clock.

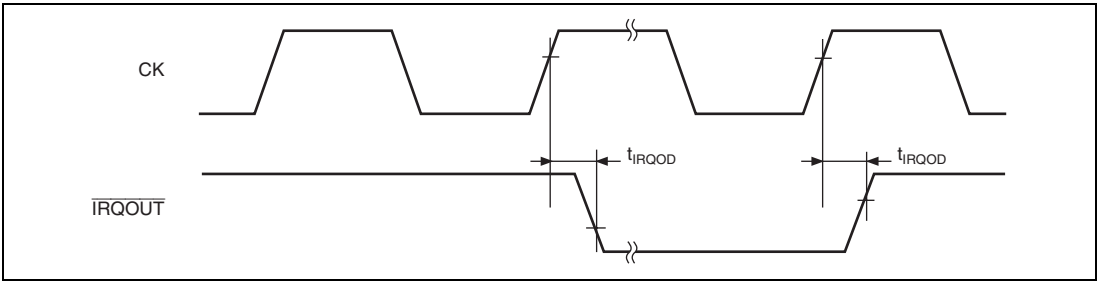
2. In standby mode,  $t_{\text{RESW}} = t_{\text{OSC2}}$  (10 ms).
3. In standby mode,  $t_{\text{MRESW}} = t_{\text{OSC2}}$  (10 ms).
4.  $t_{\text{Bcyc}}$  indicates the bus clock cycle time ( $B\phi = CK$ ).



**Figure 21.5 Reset Input Timing**



**Figure 21.6 Interrupt Signal Input Timing**



**Figure 21.7 Interrupt Signal Output Timing**



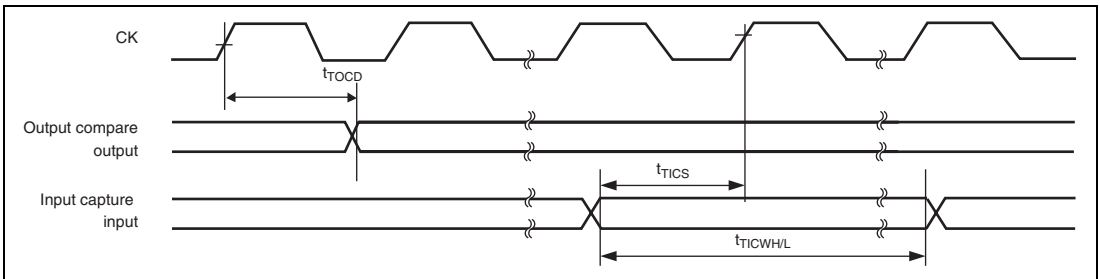
### 21.3.3 Multi Function Timer Pulse Unit 2 (MTU2) Timing

**Table 21.7 Multi Function Timer Pulse Unit 2 (MTU2) Timing**

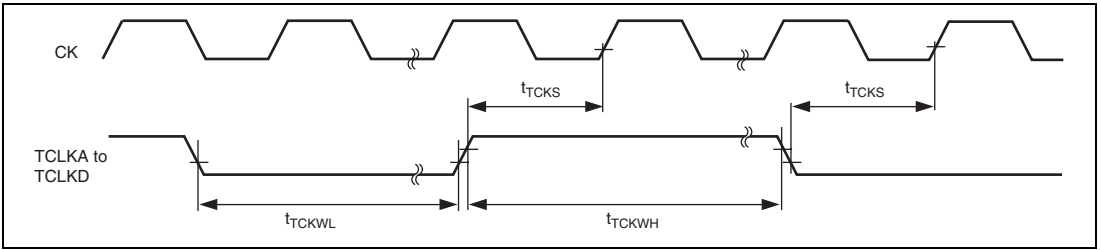
Conditions:  $V_{CC} = AV_{CC} = 4.0 \text{ V to } 5.5 \text{ V}$ ,  $V_{SS} = PLLV_{SS} = AV_{SS} = 0 \text{ V}$ ,  
 $T_a = -20 \text{ to } +85^\circ\text{C}$  (consumer specifications),  
 $T_a = -40 \text{ to } +85^\circ\text{C}$  (industrial specifications)

Item	Symbol	Min.	Max.	Unit	Reference Figure
Output compare output delay time (reference values)	$t_{TOCD}$	—	50	ns	Figure 21.8
Input capture input setup time (reference values)	$t_{TICS}$	20	—	ns	
Input capture input pulse width (single edge)	$t_{TICWH/L}$	1.5	—	$t_{MPcyc}$	
Input capture input pulse width (both edges)	$t_{TICWH/L}$	2.5	—	$t_{MPcyc}$	
Timer input setup time (reference values)	$t_{TCKS}$	20	—	ns	Figure 21.9
Timer clock pulse width (single edge)	$t_{TCKWH/L}$	1.5	—	$t_{MPcyc}$	
Timer clock pulse width (both edges)	$t_{TCKWH/L}$	2.5	—	$t_{MPcyc}$	
Timer clock pulse width (phase counting mode)	$t_{TCKWH/L}$	2.5	—	$t_{MPcyc}$	

Note:  $t_{MPcyc}$  indicates the MTU2 clock ( $MP\phi$ ) cycle.



**Figure 21.8 MTU2 Input/Output Timing**



**Figure 21.9 MTU2 Clock Input Timing**

### 21.3.4 I/O Port Timing

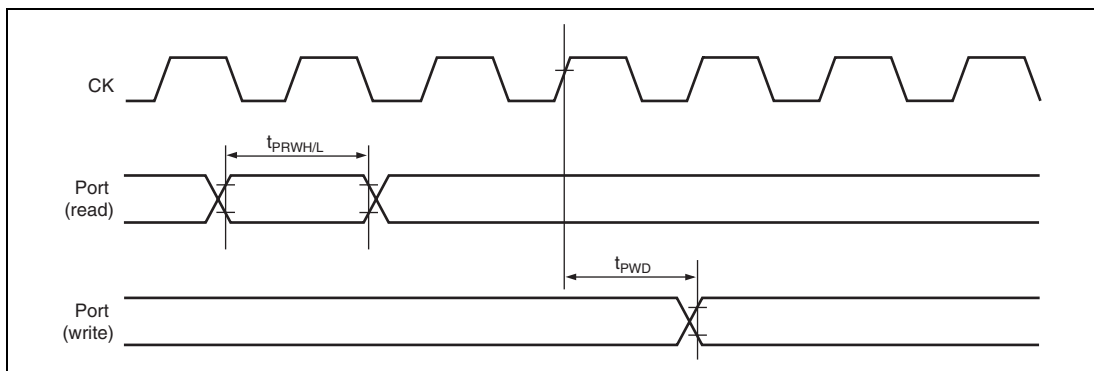
**Table 21.8 I/O Port Timing**

Conditions:  $V_{CC} = AV_{CC} = 4.0\text{ V to }5.5\text{ V}$ ,  $V_{SS} = PLLV_{SS} = AV_{SS} = 0\text{ V}$ ,

$T_a = -20\text{ to }+85^\circ\text{C}$  (consumer specifications),

$T_a = -40\text{ to }+85^\circ\text{C}$  (industrial specifications)

Item	Symbol	Min.	Max.	Unit	Reference Figure
Port output data delay time (reference values)	$t_{PWD}$	—	50	ns	Figure 21.10
Port input low pulse width	$t_{PRWL}$	2	—	$t_{Pcyt}$	
Port input high pulse width	$t_{PRWH}$	2	—	$t_{Pcyt}$	


**Figure 21.10 I/O Port Input/Output Timing**

### 21.3.5 Watchdog Timer (WDT) Timing

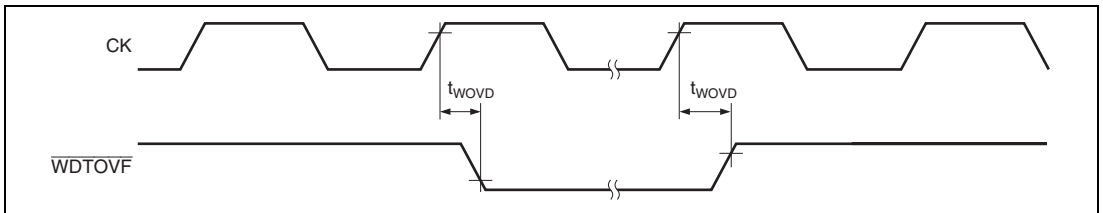
**Table 21.9 Watchdog Timer (WDT) Timing**

Conditions:  $V_{CC} = AV_{CC} = 4.0\text{ V to }5.5\text{ V}$ ,  $V_{SS} = PLLV_{SS} = AV_{SS} = 0\text{ V}$ ,

$T_a = -20\text{ to }+85^\circ\text{C}$  (consumer specifications),

$T_a = -40\text{ to }+85^\circ\text{C}$  (industrial specifications)

Item	Symbol	Min.	Max.	Unit	Reference Figure
$\overline{\text{WDTOVF}}$ delay time (reference values)	$t_{\text{WOVD}}$	—	50	ns	Figure 21.11



**Figure 21.11 WDT Timing**

### 21.3.6 Serial Communication Interface (SCI) Timing

**Table 21.10 Serial Communication Interface (SCI) Timing**

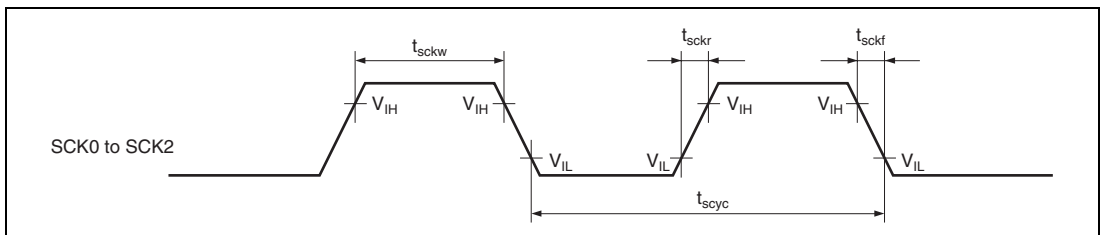
Conditions:  $V_{CC} = AV_{CC} = 4.0\text{ V to }5.5\text{ V}$ ,  $V_{SS} = PLLV_{SS} = AV_{SS} = 0\text{ V}$ ,

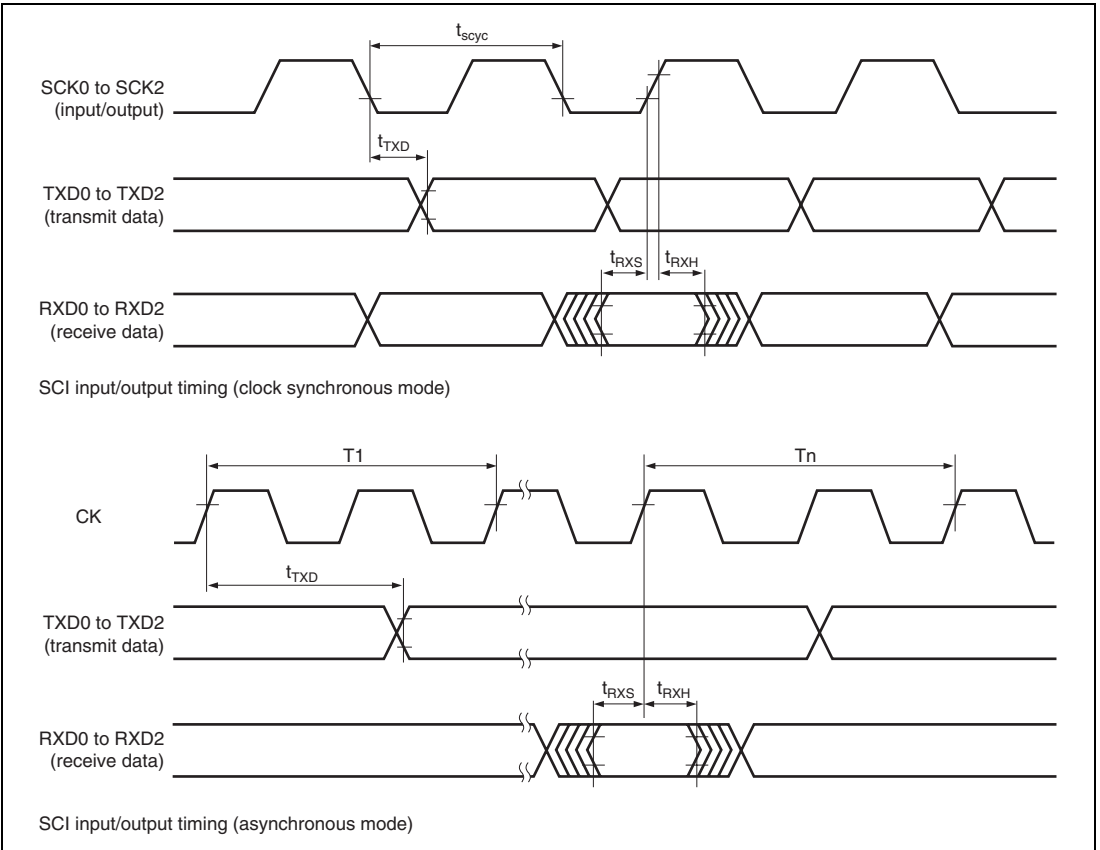
$T_a = -20\text{ to }+85^\circ\text{C}$  (consumer specifications),

$T_a = -40\text{ to }+85^\circ\text{C}$  (industrial specifications)

Item		Symbol	Min.	Max.	Unit	Reference Figure
Input clock cycle (asynchronous)		$t_{scyc}$	4	—	$t_{pcyc}$	Figure 21.12
Input clock cycle (clock synchronous)		$t_{scyc}$	6	—	$t_{pcyc}$	
Input clock pulse width		$t_{sckw}$	0.4	0.6	$t_{scyc}$	
Input clock rising time		$t_{sckr}$	—	1.5	$t_{pcyc}$	
Input clock falling time		$t_{sckf}$	—	1.5	$t_{pcyc}$	
Transmit data delay time	Asynchronous	$t_{TXD}$	—	$4 t_{pcyc} + 10$	ns	Figure 21.13
Receive data setup time		$t_{RXS}$	$4 t_{pcyc}$	—	ns	
Receive data hold time		$t_{RXH}$	$4 t_{pcyc}$	—	ns	
Transmit data delay time	Clock synchronous	$t_{TXD}$	—	$3 t_{pcyc} + 10$	ns	
Receive data setup time		$t_{RXS}$	$2 t_{pcyc} + 50$	—	ns	
Receive data hold time		$t_{RXH}$	$2 t_{pcyc}$	—	ns	

Note:  $t_{pcyc}$  indicates the peripheral clock ( $P\phi$ ) cycle.


**Figure 21.12 Input Clock Timing**



**Figure 21.13 SCI Input/Output Timing**

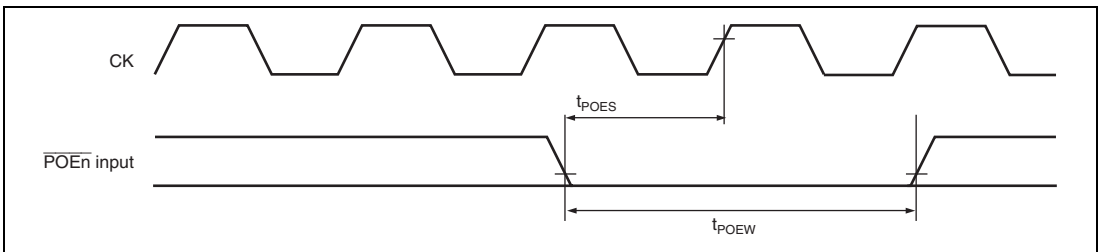
### 21.3.7 Port Output Enable (POE) Timing

**Table 21.11 Port Output Enable (POE) Timing**

Conditions:  $V_{CC} = AV_{CC} = 4.0\text{ V to }5.5\text{ V}$ ,  $V_{SS} = PLLV_{SS} = AV_{SS} = 0\text{ V}$ ,  
 $T_a = -20\text{ to }+85^\circ\text{C}$  (consumer specifications),  
 $T_a = -40\text{ to }+85^\circ\text{C}$  (industrial specifications)

Item	Symbol	Min.	Max.	Unit	Reference Figure
$\overline{\text{POE}}$ input setup time (reference values)	$t_{\text{POES}}$	50	—	ns	Figure 21.14
POE input pulse width	$t_{\text{POEW}}$	1.5	—	$t_{\text{pcyc}}$	

Note:  $t_{\text{pcyc}}$  indicates the peripheral clock (P $\phi$ ) cycle.



**Figure 21.14  $\overline{\text{POE}}$  Input Timing**

### 21.3.8 A/D Converter Timing

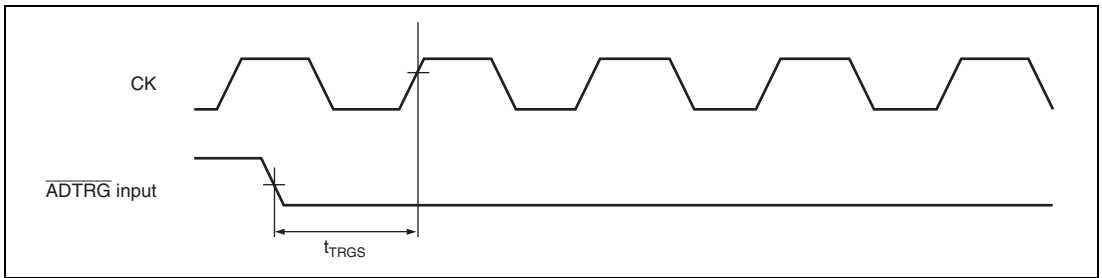
**Table 21.12 A/D Converter Timing**

Conditions:  $V_{CC} = AV_{CC} = 4.0\text{ V to }5.5\text{ V}$ ,  $V_{SS} = PLLV_{SS} = AV_{SS} = 0\text{ V}$ ,

$T_a = -20\text{ to }+85^\circ\text{C}$  (consumer specifications),

$T_a = -40\text{ to }+85^\circ\text{C}$  (industrial specifications)

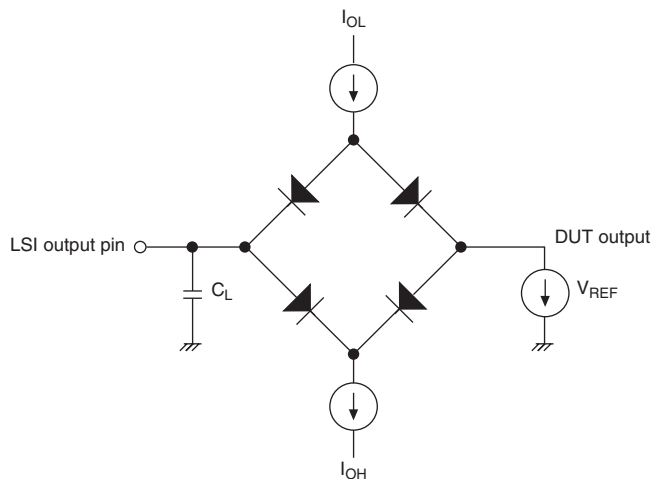
Item	Symbol	Min.	Typ.	Max.	Unit	Reference Figure
External trigger input start delay time (reference values)	$t_{TRGS}$	25	—	—	ns	Figure 21.15


**Figure 21.15 External Trigger Input Timing**



### 21.3.9 Conditions for Testing AC Characteristics

- Input signal level:  $V_{IL}$  (Max.)/ $V_{IH}$  (Min.)
- Output signal reference level: 2.0 V (high level), 0.8 V (low level)



- Notes:
1.  $C_L$  is the total value that includes the capacitance of the measurement instrument and is set as follows for the respective pins.  
30pF: All other output pins
  2.  $I_{OL} = 1.6$  mA and  $I_{OH} = -200$  mA in the test conditions.

**Figure 21.16 Output Load Circuit**

## 21.4 A/D Converter Characteristics

**Table 21.13 A/D Converter Characteristics**

Conditions:  $V_{CC} = AV_{CC} = 4.0 \text{ V to } 5.5 \text{ V}$ ,  $V_{SS} = PLLV_{SS} = AV_{SS} = 0 \text{ V}$ ,

$T_a = -20 \text{ to } +85^\circ\text{C}$  (consumer specifications),

$T_a = -40 \text{ to } +85^\circ\text{C}$  (industrial specifications)

Item	Min.	Typ.	Max.	Unit
Resolution	10	10	10	bit
A/D conversion time	—	—	2.0	$\mu\text{s}$
Analog input capacitance	—	—	20	pF
Permitted analog signal source impedance	—	—	$1^{*2}/3^{*1}$	k $\Omega$
Non-linear error	—	—	$\pm 3.0^{*1}/\pm 5.0^{*2}$	LSB
Offset error	—	—	$\pm 3.0^{*1}/\pm 5.0^{*2}$	LSB
Full-scale error	—	—	$\pm 3.0^{*1}/\pm 5.0^{*2}$	LSB
Quantization error	—	—	$\pm 0.5$	LSB
Absolute error	—	—	$\pm 4.0^{*1}/\pm 6.0^{*2}$	LSB

Notes: 1. It is assumed that A/D conversion time  $\geq 4.0 \mu\text{s}$ .

2. It is assumed that A/D conversion time  $< 4.0 \mu\text{s}$ .

## 21.5 Flash Memory Characteristics

**Table 21.14 Flash Memory Characteristics**

Conditions:  $V_{CC} = AV_{CC} = 4.0\text{ V to }5.5\text{ V}$ ,  $V_{SS} = PLLV_{SS} = AV_{SS} = 0\text{ V}$ ,

$T_a = -20\text{ to }+85^\circ\text{C}$  (consumer specifications),

$T_a = -40\text{ to }+85^\circ\text{C}$  (industrial specifications)

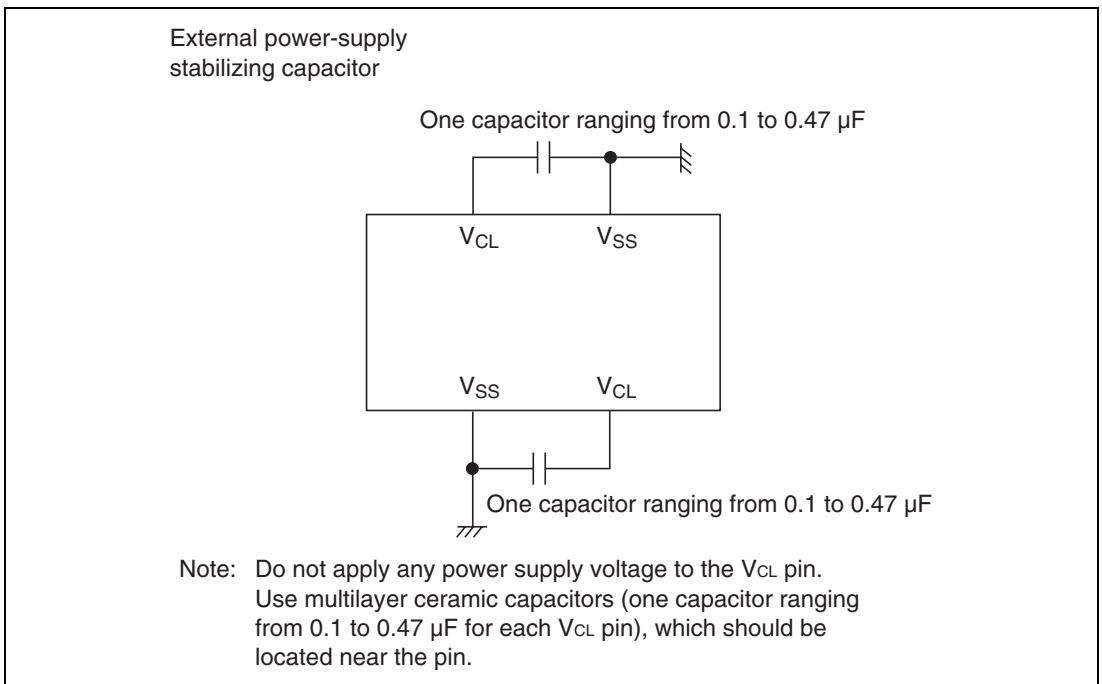
Item	Symbol	Min.	Typ.	Max.	Unit
Programming time* <sup>1</sup> * <sup>2</sup> * <sup>4</sup>	$t_p$	—	1	10	ms/128 bytes
Erase time* <sup>1</sup> * <sup>2</sup> * <sup>4</sup>	$t_E$	—	40	130	ms/4 Kbytes block
		—	300	800	ms/32 Kbytes block
		—	600	1500	ms/64 Kbytes block
Programming time (total) * <sup>1</sup> * <sup>2</sup> * <sup>4</sup>	$\Sigma t_p$	—	1.2	3	s/128 Kbytes
		—	0.6	1.5	s/64 Kbytes
Erase time (total) * <sup>1</sup> * <sup>2</sup> * <sup>4</sup>	$\Sigma t_E$	—	1.3	3.5	s/128 Kbytes
		—	0.7	2	s/64 Kbytes
Programming and erase time (total) * <sup>1</sup> * <sup>2</sup> * <sup>4</sup>	$\Sigma t_{PE}$	—	2.5	6.5	s/128 Kbytes
		—	1.3	3.5	s/64 Kbytes
Reprogramming count	$N_{WEC}$	100* <sup>3</sup>	—	—	Times

- Notes: 1. Programming/erasure time is data-dependent.  
 2. Programming/erasure time does not include data transfer time.  
 3. Minimum number to guarantee all the characteristics after reprogramming. (Guaranteed within the range from 1 to min. value)  
 4. Characteristics when reprogramming is performed within the specified number of times including min. value.

## 21.6 Usage Note

### 21.6.1 Notes on Connecting $V_{CL}$ Capacitor

This LSI includes an internal step-down circuit to automatically reduce the internal power supply voltage to an appropriate level. Between this internal stepped-down power supply ( $V_{CL}$  pin) and the  $V_{SS}$  pin, a capacitor (ranging from 0.1 to 0.47  $\mu\text{F}$ ) for stabilizing the internal voltage needs to be connected. Connection of the external capacitor is shown in figure 21.17. The external capacitor should be located near the pin. Do not apply any power supply voltage to the  $V_{CL}$  pin.



**Figure 21.17 Connection of  $V_{CL}$  Capacitor**

# Appendix

## A. Pin States

Pin initial states differ according to MCU operating modes. See section 15, Pin Function Controller (PFC), for details.

**Table A.1 Pin States (SH7125)**

Pin Function		Pin State					
		Reset State		Power-Down State		Oscillation Stop Detected	POE Function Used
Type	Pin Name	Power-On	Manual	Software Standby	Sleep		
Clock	XTAL	O	O	L	O	O	O
	EXTAL	I	I	I	I	I	I
System control	$\overline{\text{RES}}$	I	I	I	I	I	I
	$\overline{\text{MRES}}$	Z	I	Z	I	Z	I
	$\overline{\text{WDTOVF}}$	O* <sup>2</sup>	O	O	O	O	O
Operating mode control	MD1	I	I	I	I	I	I
	$\overline{\text{ASEMD0}}$	I* <sup>3</sup>	I* <sup>3</sup>	I* <sup>3</sup>	I* <sup>3</sup>	I* <sup>3</sup>	I* <sup>3</sup>
	FWE	I	I	I	I	I	I
Interrupt	NMI	I	I	I	I	I	I
	IRQ0 to IRQ3	Z	I	I	I	I	I
	$\overline{\text{IRQOUT}}$	Z	O	Z	O	Z	O
MTU2	TCLKA to TCLKD	Z	I	Z	I	I	I
	TIOC0A to TIOC0D	Z	I/O	K* <sup>1</sup>	I/O	I/O	Z
	TIOC1A, TIOC1B	Z	I/O	K* <sup>1</sup>	I/O	I/O	I/O
	TIOC2A, TIOC2B	Z	I/O	K* <sup>1</sup>	I/O	I/O	I/O
	TIOC3A, TIOC3C	Z	I/O	K* <sup>1</sup>	I/O	I/O	I/O
	TIOC3B, TIOC3D	Z	I/O	Z	I/O	Z	Z
MTU2	TIOC4A to TIOC4D	Z	I/O	Z	I/O	Z	Z
	TIC5U, TIC5V, TIC5W	Z	I	Z	I	I	I
POE	$\overline{\text{POE0}}, \overline{\text{POE1}}, \overline{\text{POE8}}$	Z	I	Z	I	I	I
	$\overline{\text{POE3}}$	I* <sup>3</sup>	I* <sup>3</sup>	Z	I* <sup>3</sup>	I* <sup>3</sup>	I* <sup>3</sup>

Pin Function		Pin State					
		Reset State		Power-Down State		Oscillation Stop Detected	POE Function Used
Type	Pin Name	Power-On	Manual	Software Standby	Sleep		
SCI	SCK0 to SCK2	Z	I/O	Z	I/O	I/O	I/O
	RXD0 to RXD2	Z	I	Z	I	I	I
	TXD0 to TXD2	Z	O	O <sup>*1</sup>	O	O	O
A/D Converter	AN0 to AN7	Z	I	Z	I	I	I
	$\overline{\text{ADTRG}}$	Z	I	Z	I	I	I
I/O Ports	PA0 to PA15	Z	I/O	K <sup>*1</sup>	I/O	I/O	I/O
	PB1 to PB3, PB5, PB16	Z	I/O	K <sup>*1</sup>	I/O	I/O	I/O
	PE0 to PE3	Z	I/O	K <sup>*1</sup>	I/O	I/O	Z
	PE4 to PE8, PE10	Z	I/O	K <sup>*1</sup>	I/O	I/O	I/O
	PE9, PE11 to PE15	Z	I/O	Z	I/O	Z	Z
	PF0 to PF7	Z	I	Z	I	I	I

## [Legend]

I: Input

O: Output

H: High-level output

L: Low-level output

Z: High-impedance

K: Input pins become high-impedance, and output pins retain their state.

- Notes:
1. Output pins become high-impedance when the HIZ bit in standby control register 6 (STBCR6) is set to 1.
  2. Becomes input during a power-on reset. Pull-up to prevent erroneous operation. Pull-down with a resistance of at least 1 M $\Omega$  as required.
  3. Pulled-up inside the LSI when there is no input.

Table A.2 Pin States (SH7124)

Pin Function		Pin State					
		Reset State		Power-Down State		Oscillation Stop Detected	POE Function Used
		Power-On	Manual	Software Standby	Sleep		
Type	Pin Name	Power-On	Manual	Software Standby	Sleep	Oscillation Stop Detected	POE Function Used
Clock	XTAL	O	O	L	O	O	O
	EXTAL	I	I	I	I	I	I
System control	$\overline{\text{RES}}$	I	I	I	I	I	I
	$\overline{\text{MRES}}$	Z	I	Z	I	Z	I
	WDTOVF	O* <sup>2</sup>	O	O	O	O	O
Operating mode control	MD1	I	I	I	I	I	I
	$\overline{\text{ASEMD0}}$	I* <sup>3</sup>	I* <sup>3</sup>	I* <sup>3</sup>	I* <sup>3</sup>	I* <sup>3</sup>	I* <sup>3</sup>
	FWE	I	I	I	I	I	I
Interrupt	NMI	I	I	I	I	I	I
	IRQ1 to IRQ3	Z	I	I	I	I	I
	$\overline{\text{IRQOUT}}$	Z	O	Z	O	Z	O
MTU2	TCLKA to TCLKD	Z	I	Z	I	I	I
	TIOC0A to TIOC0D	Z	I/O	K* <sup>1</sup>	I/O	I/O	Z
	TIOC3A, TIOC3C	Z	I/O	K* <sup>1</sup>	I/O	I/O	I/O
	TIOC3B, TIOC3D	Z	I/O	Z	I/O	Z	Z
	TIOC4A to TIOC4D	Z	I/O	Z	I/O	Z	Z
	TIC5U, TIC5V, TIC5W	Z	I	Z	I	I	I
POE	$\overline{\text{POE0}}, \overline{\text{POE1}}, \overline{\text{POE8}}$	Z	I	Z	I	I	I
SCI	SCK0, SCK2	Z	I/O	Z	I/O	I/O	I/O
	RXD0 to RXD2	Z	I	Z	I	I	I
	TXD0 to TXD2	Z	O	O* <sup>1</sup>	O	O	O
A/D Converter	AN0 to AN7	Z	I	Z	I	I	I

Pin Function		Pin State					
Type	Pin Name	Reset State		Power-Down State		Oscillation Stop Detected	POE Function Used
		Power-On	Manual	Software Standby	Sleep		
I/O Ports	PA0, PA1, PA3, PA4, PA6 to PA9	Z	I/O	K* <sup>1</sup>	I/O	I/O	I/O
	PB1, PB3, PB5	Z	I/O	K* <sup>1</sup>	I/O	I/O	I/O
	PE0 to PE3	Z	I/O	K* <sup>1</sup>	I/O	I/O	Z
	PE8, PE10	Z	I/O	K* <sup>1</sup>	I/O	I/O	I/O
	PE9, PE11 to PE15	Z	I/O	Z	I/O	Z	Z
	PF0 to PF7	Z	I	Z	I	I	I

## [Legend]

I: Input

O: Output

H: High-level output

L: Low-level output

Z: High-impedance

K: Input pins become high-impedance, and output pins retain their state.

- Notes:
1. Output pins become high-impedance when the HIZ bit in standby control register 6 (STBCR6) is set to 1.
  2. Becomes input during a power-on reset. Pull-up to prevent erroneous operation. Pull-down with a resistance of at least 1 MΩ as required.
  3. Pulled-up inside the LSI when there is no input.



## B. Product Code Lineup

Product Type			Product Code	Package (Package Code)
SH7125	Flash memory version (on-chip 128-kbyte)	Consumer product	R5F71253N50FP	LQFP-64 (FP-64K)
		Industrial product	R5F71253D50FP	
		Consumer product	R5F71253N50FA	QFP-64 (FP-64H)
		Industrial product	R5F71253D50FA	
	Flash memory version (on-chip 64-kbyte)	Consumer product	R5F71253N50NP	VQFN-64 (TNP-64BV)
		Industrial product	R5F71253D50NP	
		Consumer product	R5F71252N50FP	LQFP-64 (FP-64K)
		Industrial product	R5F71252D50FP	
		Consumer product	R5F71252N50FA	QFP-64 (FP-64H)
		Industrial product	R5F71252D50FA	
SH7124	Flash memory version (on-chip 128-kbyte)	Consumer product	R5F71243N50FP	LQFP-48 (FP-48F)
		Industrial product	R5F71243D50FP	
	Flash memory version (on-chip 64-kbyte)	Consumer product	R5F71242N50FP	
		Industrial product	R5F71242D50FP	
		Consumer product	R5F71242N50NP	VQFN-52
		Industrial product	R5F71242D50NP	
	Flash memory version (on-chip 32-kbyte)	Consumer product	R5F71241N50FP	LQFP-48 (FP-48F)
		Industrial product	R5F71241D50FP	
		Consumer product	R5F71241N50NP	VQFN-52
		Industrial product	R5F71241D50NP	

### C. Package Dimensions

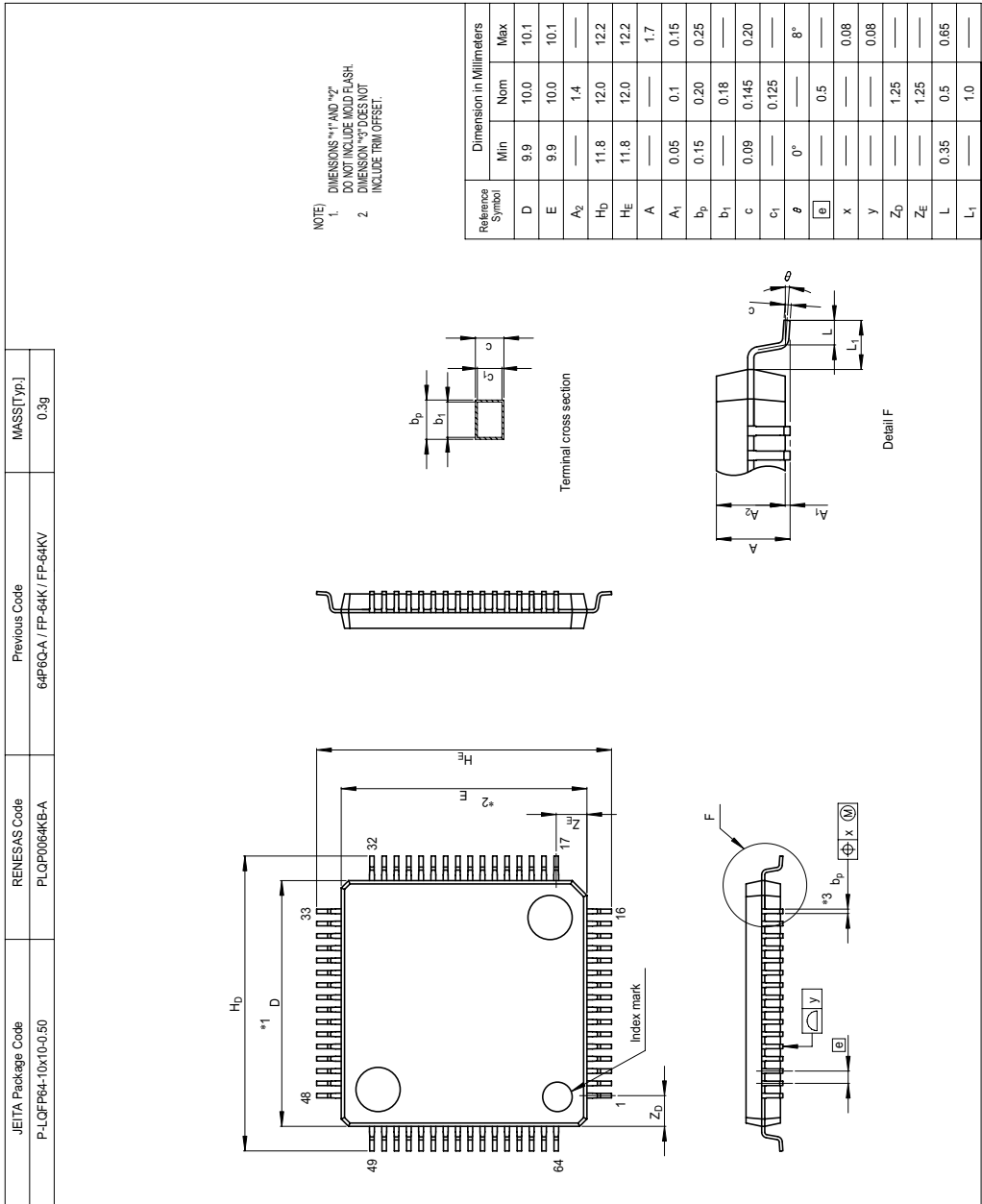


Figure C.1 LQFP-64

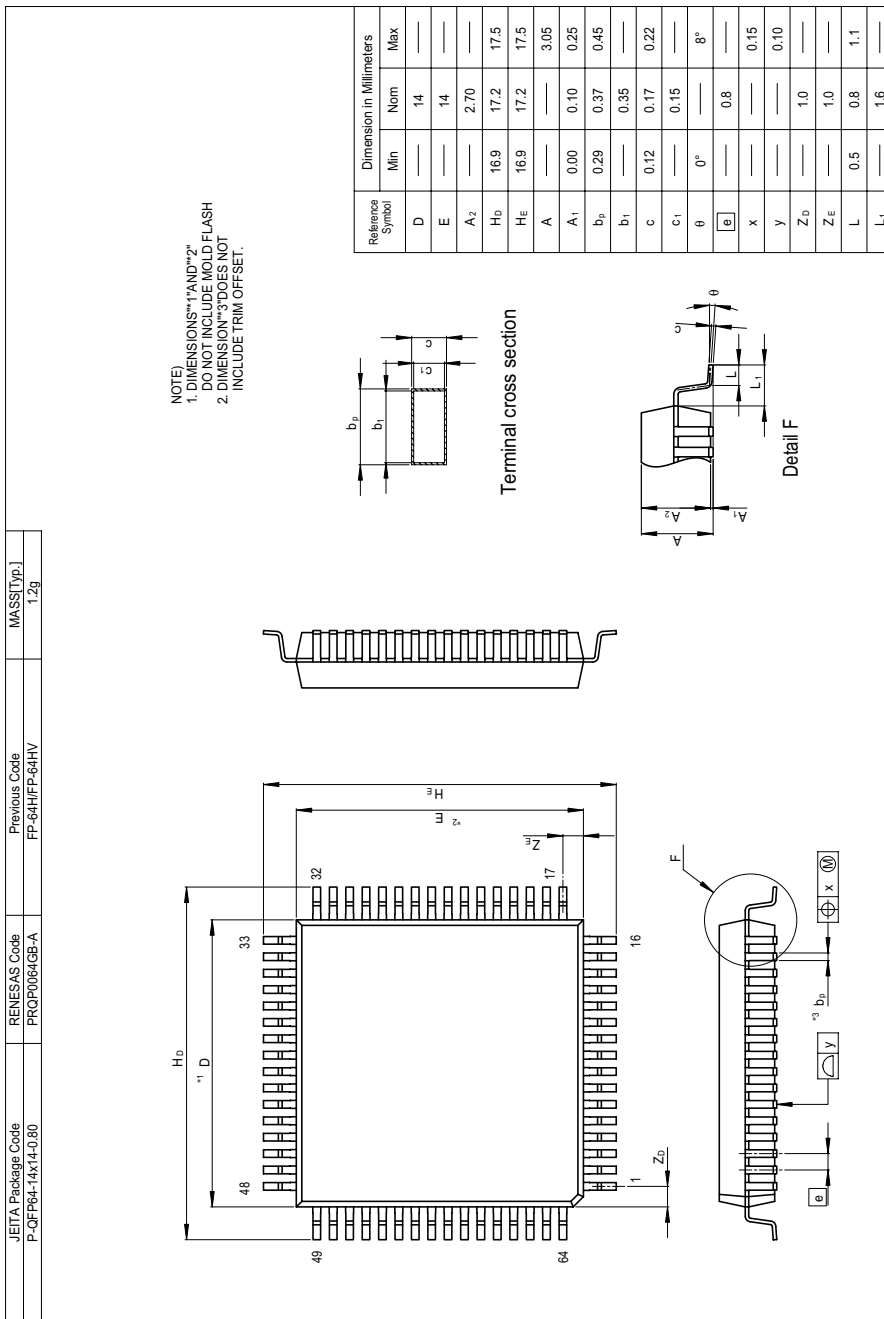


Figure C.2 QFP-64

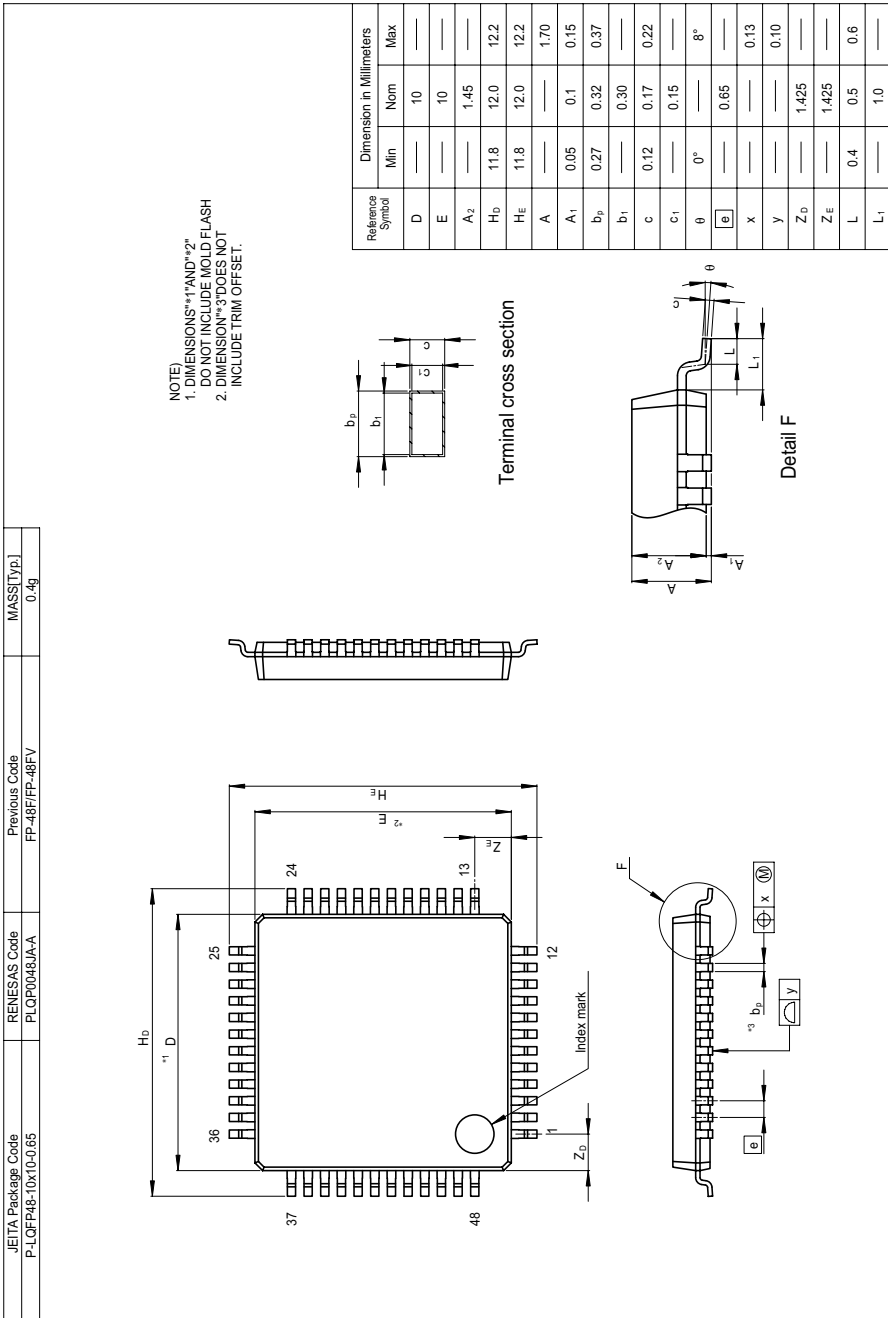


Figure C.3 LQFP-48







4.4.2 Oscillation Stop Detection Control Register (OSCCR) 64 Deleted

Bit	Bit Name	Initial Value	R/W	Description
2	OSCSTOP	0	R	Oscillation Stop Detection Flag [Setting conditions] <ul style="list-style-type: none"> <li>When a stop in the clock input is detected during normal operation</li> <li><del>When software standby mode is entered</del></li> </ul> [Clearing conditions] <ul style="list-style-type: none"> <li>By a power-on reset input through the <math>\overline{\text{RES}}</math> pin</li> <li><del>When software standby mode is canceled</del></li> </ul>

4.5 Changing Frequency 65 Deleted

- After an instruction to rewrite FRQCR has been issued, the actual clock frequencies will change after  $(1 \text{ to } 24n) \text{ cyc} + 11B\phi + 7P\phi$ .  
 n: Division ratio specified by the BFC bit in FRQCR (~~1~~, 1/2, 1/4, or 1/8)  
 cyc: Clock obtained by dividing EXTAL by 8 with the PLL.



**Item**

**Page Revision (See Manual for Details)**

Table 5.6 Bus Cycles and Address Errors

77 Deleted

Bus Cycle			
Type	Bus Master	Bus Cycle Description	Address Errors
Instruction fetch	CPU	Instruction fetched from on-chip peripheral module space	Address error occurs
		<del>Instruction fetched from external memory space in single-chip mode</del>	<del>Address error occurs</del>
Data read/write	CPU	Word data accessed from even address	None (normal)
		Longword data accessed in 8-bit on-chip peripheral module space	None (normal)
		<del>Reserved space accessed when in single-chip mode</del>	<del>Address error occurs</del>

Table 8.1 Address Map

147 Amended

Address	Type of Memory	Size			Bus Width
		128 Kbytes Version	64 Kbytes Version	32 Kbytes Version	
H'00020000 to H'FFFF9FFF	Reserved	—	—	—	—
H'84000000 to H'84007FFF	On-chip FLASH programming area	128 Kbytes	64 Kbytes	32 Kbytes	8
H'84008000 to H'8400FFFF				Reserved	
H'84010000 to H'8401FFFF			Reserved		
H'84020000 to H'FFFF9FFF	Reserved	—	—	—	—
H'FFFA000 to H'FFFBFFF	On-chip RAM	8 Kbytes	8 Kbytes	8 Kbytes	32
H'FFFC000 to H'FFFFFF	On-chip peripheral I/O	128 Kbytes	64 Kbytes	64 Kbytes	8/16

Figure 9.64 Example of Output Phase Switching by External Input (2)

297 Amended

Output waveform of the terminal amended.

Figure 9.66 Example of Output Phase Switching by Means of UF, VF, WF Bit Settings (2)

299 Amended

Output waveform of the terminal amended.

**Item** **Page** **Revision (See Manual for Details)**

9.5.2 A/D Converter Activation 319 Amended

**A/D Converter Activation by A/D Converter Start Request Delaying Function:** The A/D converter can be activated by generating A/D converter start request signal TRG4AN or TRG4BN when the TCNT\_4 count matches the TADCORA or TADCORB value if the **UT4AE, DT4AE, UT4BE, or DT4BE** bit in the A/D converter start request control register (TADCR) is set to 1. For details, refer to section 9.4.9, A/D Converter Start Request Delaying Function.

12.7.4 Sending a Break Signal 472 Added

...Until TE bit is set to 1 (enabling transmission) after initializing, TXD pin does not work. During the period, mark status is performed by SPB0DT bit. Therefore, the SPB0DT bit should be set to 1 **at first** (high level output)....

Table 13.3 Channel Select List 483 Amended

Analog Input Channels					
2-Channel Scan Mode* (Activated by software)					
Bit 2	Bit 1	Bit 0			
CH2	CH1	CH0	A/D_0	A/D_1	
0	0	0	AN0	AN4	

484 Added

Table of Activated by Triggers MTU2 or etc.

Figure 13.4 Example of 2-Channel Scanning 494 Amended



17.2.5 Block Division 580 Added

The user MAT can be erased in this divided-block units and the erase-block number of EB0 to EB9 is specified when erasing. The user MAT is divided into 16 Kbytes **(two blocks)** for 32-Kbyte ROM version.

Figure 17.4 Block Division of User MAT 580 Amended

**Item**

**Page Revision (See Manual for Details)**

17.4.2 (5) Flash Transfer Destination Address Register (FTDAR)

591 Amended

FTDAR specifies the on-chip RAM address to which the on-chip program is downloaded.

Make settings for FTDAR before writing 1 to the SCO bit in FCCS. The initial value is H'00, ~~which points to the start address (H'FFFFA000) in on-chip RAM.~~

592 Amended

Bit	Bit Name	Initial Value	R/W	Description
6 to 0	TDA[6:0]	All 0	R/W	••• H'00, H'01, H'05 to H'7F: Setting prohibited when downloading by the SCO bit with user program mode. If this value is set, the TDER bit (bit 7) is set to 1 to abort the download processing. When not using user program mode, set H'00 to the TDA bits.

Table 21.1 Absolute Maximum Ratings

707 Deleted

Item	Symbol	Value	Unit
Analog power supply voltage	$AV_{CC}$	-0.3 to + 7.0	V
Analog reference voltage	$AV_{ref}$	-0.3 to $AV_{CC} + 0.3$	V
Analog input voltage	$V_{an}$	-0.3 to $AV_{CC} + 0.3$	V

Table 21.2 DC Characteristics

709 Amended

Item	Symbol	Min.	Typ.	Max.	Unit	Test Conditions	
Output high voltage	TIOC3B, TIOC3D, TIOC4A to TIOC4D	$V_{OH}$	$V_{CC} - 0.8$	—	V	$I_{OH} = -5 \text{ mA}$ , $V_{CC} = 4.5 \text{ V}$ to 5.5 V	
Output low voltage	TIOC3B, TIOC3D, TIOC4A to TIOC4D	$V_{OL}$	—	—	1.0	V	$I_{OL} = 15 \text{ mA}$ , $V_{CC} = 4.5 \text{ V}$ to 5.5 V
			—	—	0.6	V	$I_{OL} = 10 \text{ mA}$ , $V_{CC} = 4.5 \text{ V}$ to 5.5 V
			—	—	0.4	V	$I_{OL} = 8 \text{ mA}$ , $V_{CC} = 4.5 \text{ V}$ to 5.5 V



# Index

- A**
- A/D conversion time ..... 492
  - A/D converter (ADC) ..... 475
  - A/D converter activation ..... 319
  - A/D converter characteristics ..... 726
  - A/D converter interrupt source ..... 495
  - A/D converter start request delaying function ..... 308
  - Absolute accuracy ..... 496
  - Absolute maximum ratings ..... 707
  - AC characteristics ..... 711
  - AC characteristics measurement conditions ..... 725
  - Address error ..... 77, 86, 660
  - Addressing modes ..... 26
  - Arithmetic operation instructions ..... 39
  - Asynchronous mode ..... 411, 444
- B**
- Boot mode ..... 607
  - Branch instructions ..... 43
  - Break comparison conditions ..... 113
  - Break detection and processing ..... 472
  - Break on data access cycle ..... 135
  - Break on instruction fetch cycle ..... 135
  - Bus state controller (BSC) ..... 147
- C**
- Calculating exception handling vector table addresses ..... 74
  - Changing frequency ..... 65
  - Clock (MP $\phi$ ) for the MTU2 module ..... 55
  - Clock frequency control circuit ..... 57
  - Clock operating mode ..... 59
  - Clock pulse generator (CPG) ..... 55
  - Clock synchronous mode ..... 411, 454
  - Clock timing ..... 712
  - CMT interrupt sources ..... 509
  - Compare match timer (CMT) ..... 503
  - Complementary PWM mode ..... 267
  - Connecting crystal resonator ..... 66
  - Continuous scan mode ..... 489
  - Control signal timing ..... 714
  - CPU ..... 17
  - Crystal oscillator ..... 57
- D**
- Data transfer instructions ..... 37
  - DC Characteristics ..... 708
  - Dead time compensation ..... 313
  - Divider ..... 57
- E**
- Error protection ..... 621
  - Exception handling ..... 71
  - Exception handling state ..... 47
  - External clock input method ..... 67
  - External pulse width measurement ..... 312
  - External trigger input timing ..... 493
- F**
- Features of instructions ..... 23
  - Flash Memory ..... 575
  - Flash memory characteristics ..... 727
  - Flash memory configuration ..... 580
  - Flow of the user break operation ..... 134
  - Full-scale error ..... 496
  - Function for detecting oscillator stop ..... 68

## G

General illegal instructions .....	82
General registers .....	19
Global-base register (GBR) .....	20

## H

Hardware protection .....	620
---------------------------	-----

## I

I/O ports .....	551
Illegal slot instructions .....	82
Immediate data formats .....	23
Influences on absolute accuracy .....	499
Initial user branch processing time .....	625
Initial values of control register .....	21
Initial values of general register .....	21
Initial values of system register .....	21
Initiation intervals of user branch processing .....	625
Instruction formats .....	29
Instruction set .....	33
Interrupt controller (INTC) .....	89
Interrupt exception handling vector table .....	104
Interrupt priority .....	80
Interrupt response time .....	111
Interrupt sequence .....	107
Interrupts .....	79
IRQ interrupts .....	102

## L

List of registers .....	675
Logic operation instructions .....	41

## M

Manual reset .....	76
MCU operating modes .....	49
Module standby mode .....	674
Module standby mode setting .....	474, 499, 510, 660
MTU2 functions .....	152
MTU2 interrupts .....	317
MTU2 output pin initialization .....	348
Multi-function timer pulse unit 2 (MTU2) .....	151
Multiply and accumulate registers (MACH and MACL) .....	21
Multiprocessor communication function .....	463

## N

NMI interrupt .....	102
Nonlinearity error .....	496
Note on Changing Operating Mode .....	54
Note on crystal resonator .....	69
Notes on board design .....	69, 500
Notes on connecting V <sub>CL</sub> capacitor .....	728
Notes on noise countermeasures .....	501
Notes on register access (WDT) .....	407
Notes on slot illegal instruction exception handling .....	87

## O

Off-board programming mode .....	658
Offset error .....	496
On-board programming mode .....	607
On-chip peripheral module interrupts .....	103
Operating clock for each module .....	58

<b>P</b>	
Package dimensions.....	734
PC trace .....	138
Peripheral clock (P $\phi$ ) .....	55
Permissible signal source impedance .....	499
Pin function controller (PFC) .....	513
Pin states of this LSI in each processing state .....	729
Port output enable (POE).....	381
Power-down modes .....	661
Power-down state .....	47
Power-on reset .....	75
Procedure register (PR).....	21
Product code lineup .....	733
Program counter (PC).....	21
Program execution state.....	47
<b>Q</b>	
Quantization error.....	496
<b>R</b>	
RAM.....	659
Range of analog power supply and other pin settings.....	500
Register	
ADCR.....	482
ADCSR.....	479
ADDR0 to ADDR7.....	479
ADTSR.....	485
BAMRA .....	116
BAMRB.....	122
BARA .....	116
BARB .....	121
BBRA .....	117
BBRB .....	125
BDMRA .....	120
BDMRB.....	124
BDRA .....	119
BDRB.....	123
BETR .....	131
BRCR.....	127
BRDR.....	133
BRSR .....	132
CMCNT .....	507
CMCOR .....	507
CMCSR.....	505
CMSTR.....	505
DPFR .....	594
FCCS.....	586
FEBS .....	603
FECS .....	589
FKEY .....	590
FMPAR.....	599
FMPDR.....	600
FPCS .....	589
FPEFEQ.....	595
FPFR .....	598, 601, 604
FRQCR .....	61
FTDAR .....	591
FUBRA .....	596
ICR0.....	93
ICSR1.....	385
ICSR3.....	389
IFCR.....	549
IPRA to IPRF and IPRH to IPRM .....	99
IRQCR .....	94
IRQSR.....	96
OCSR1 .....	388
OSCCR .....	64
PACRL1.....	522
PACRL2.....	522
PACRL3.....	522
PACRL4.....	522
PADRL .....	553
PAIORL .....	522
PAPRL.....	557
PBCRH1 .....	534
PBCRL1 .....	534

PBCRL2 .....	534	TBTER.....	230
PBDRH.....	560	TBTM .....	202
PBDRL .....	560	TCBR.....	227
PBIORH .....	533	TCDR.....	226
PBIORL.....	533	TCNT .....	209
PBPRH .....	563	TCNTCMPCLR.....	188
PBPRL .....	563	TCNTS.....	225
PECRL1.....	539	TCR.....	162
PECRL2.....	539	TDDR .....	226
PECRL3.....	539	TDER.....	232
PECRL4.....	539	TGCR.....	223
PEDRL .....	568	TGR .....	209
PEIORL.....	539	TICCR.....	203
PEPRL .....	571	TIER .....	189
PFDRL.....	574	TIOR .....	169
POECR1 .....	393	TITCNT .....	229
POECR2 .....	394	TITCR .....	227
RAMCR.....	670	TMDR.....	166
SCBRR (SCI) .....	431	TOCR1.....	216
SCRDR.....	415	TOCR2.....	219
SCRSR (SCI).....	415	TOER.....	215
SCSCR (SCI).....	419	TOLBR .....	222
SCSDCR.....	430	TRWER .....	214
SCSMR (SCI).....	416	TSR.....	194
SCSPTR (SCI).....	428	TSTR.....	210
SCSSR .....	422	TSYR .....	212
SCTDR .....	416	TWCR.....	233
SCTSR (SCI).....	415	WTCNT .....	404
SPOER.....	391	WTCSR.....	405
STBCR1 .....	664	Register address table	
STBCR2 .....	665	(in the order from lower addresses) .....	676
STBCR3 .....	666	Register bit list.....	684
STBCR4 .....	667	Register data format.....	22
STBCR5 .....	668	Register states in each operating mode ...	698
STBCR6 .....	669	Reset state .....	47
TADCOBRA_4 .....	208	Reset-synchronized PWM mode.....	264
TADCOBRB_4 .....	208	RISC-type .....	23
TADCORA_4.....	208		
TADCORB_4.....	208		
TADCR .....	205		



<b>S</b>		
SCI interrupt sources .....	469	
SCSPTR and SCI pins .....	470	
Sending a break signal .....	472	
Sequential break .....	137	
Serial communication interface (SCI) ...	411	
Shift instructions .....	42	
Single chip mode .....	50	
Single mode .....	489	
Single-cycle scan mode .....	490	
Sleep mode .....	671	
Software protection.....	621	
Software standby mode.....	672	
Stack after interrupt exception handling .....	110	
Stack states after exception handling ends.....	84	
Status register (SR).....	19	
System control instructions.....	44	
<b>T</b>		
Target pins and conditions for high- impedance control.....	396	
		The address map for the operating modes. 51
		Trap instructions .....
		81
		<b>U</b>
		User break controller (UBC).....
		113
		User break interrupt .....
		103
		User MAT .....
		580
		User program mode.....
		611
		Using interval timer mode.....
		409
		Using watchdog timer mode .....
		408
		<b>V</b>
		Vector numbers and vector table address offsets.....
		73
		Vector-base register (VBR) .....
		20
		<b>W</b>
		Watchdog timer (WDT).....
		401



---

**Renesas 32-Bit RISC Microcomputer  
Hardware Manual  
SH7125 Group, SH7124 Group**

Publication Date: Rev.1.00, Mar. 25, 2005  
Rev.4.00, Jul. 25, 2008  
Published by: Sales Strategic Planning Div.  
Renesas Technology Corp.  
Edited by: Customer Support Department  
Global Strategic Communication Div.  
Renesas Solutions Corp.

Renesas Technology Corp. Sales Strategic Planning Div. Nippon Bldg., 2-6-2, Ohte-machi, Chiyoda-ku, Tokyo 100-0004, Japan

---



## RENESAS SALES OFFICES

<http://www.renesas.com>

Refer to "<http://www.renesas.com/en/network>" for the latest and detailed information.

### **Renesas Technology America, Inc.**

450 Holger Way, San Jose, CA 95134-1368, U.S.A  
Tel: <1> (408) 382-7500, Fax: <1> (408) 382-7501

### **Renesas Technology Europe Limited**

Dukes Meadow, Millboard Road, Bourne End, Buckinghamshire, SL8 5FH, U.K.  
Tel: <44> (1628) 585-100, Fax: <44> (1628) 585-900

### **Renesas Technology (Shanghai) Co., Ltd.**

Unit 204, 205, AZIA Center, No.1233 Lujiazui Ring Rd, Pudong District, Shanghai, China 200120  
Tel: <86> (21) 5877-1818, Fax: <86> (21) 6887-7858/7898

### **Renesas Technology Hong Kong Ltd.**

7th Floor, North Tower, World Finance Centre, Harbour City, Canton Road, Tsimshatsui, Kowloon, Hong Kong  
Tel: <852> 2265-6688, Fax: <852> 2377-3473

### **Renesas Technology Taiwan Co., Ltd.**

10th Floor, No.99, Fushing North Road, Taipei, Taiwan  
Tel: <886> (2) 2715-2888, Fax: <886> (2) 3518-3399

### **Renesas Technology Singapore Pte. Ltd.**

1 Harbour Front Avenue, #06-10, Keppel Bay Tower, Singapore 098632  
Tel: <65> 6213-0200, Fax: <65> 6278-8001

### **Renesas Technology Korea Co., Ltd.**

Kukje Center Bldg. 18th Fl., 191, 2-ka, Hangang-ro, Yongsan-ku, Seoul 140-702, Korea  
Tel: <82> (2) 796-3115, Fax: <82> (2) 796-2145

### **Renesas Technology Malaysia Sdn. Bhd**

Unit 906, Block B, Menara Amcorp, Amcorp Trade Centre, No.18, Jln Persiaran Barat, 46050 Petaling Jaya, Selangor Darul Ehsan, Malaysia  
Tel: <603> 7955-9390, Fax: <603> 7955-9510





# SH7125 Group, SH7124 Group Hardware Manual



Renesas Technology Corp.  
2-6-2, Ote-machi, Chiyoda-ku, Tokyo, 100-0004, Japan