

AVA TECHNOLOGY CO.

Technical Specification

Model: ND39G1

Name: .39"Seven-Segment Display

REV: A

Date: 2006-1-6

**AVA TECHNOLOGY CO.
2640 S. Myrtle Ave. Suite 6, Monrovia, CA 91016
Tel: 626-574-7726 Fax: 626-574-7732**

AVA TECHNOLOGY CO.

DESCRIPTION••

THE GREEN SOURCE COLOR DEVICES
ARE MADE WITH InGaAlP ON GaAs
SUBSTRATE LIGHT EMITTING DIODE



FEATURES

- * 0.39 inch (10.0 mm) DIGIT HEIGHT
- * CONTINUOUS UNIFORM SEGMENTS
- * LOW POWER REQUIREMENT
- * EXCELLENT CHARACTERS APPEARANCE
- * HIGH BRIGHTNESS & HIGH CONTRAST
- * WIDE VIEWING ANGLE
- * SOLID STATE RELIABILITY
- * CATEGORIZED FOR LUMINOUS INTENSITY
- * THE CHARACTERISTIC OF ENCAPXULATION
METHOD IS USE THE CHIP ON BORAD OR SMT

AVA TECHNOLOGY CO.

PACKAGE DIMENSIONS

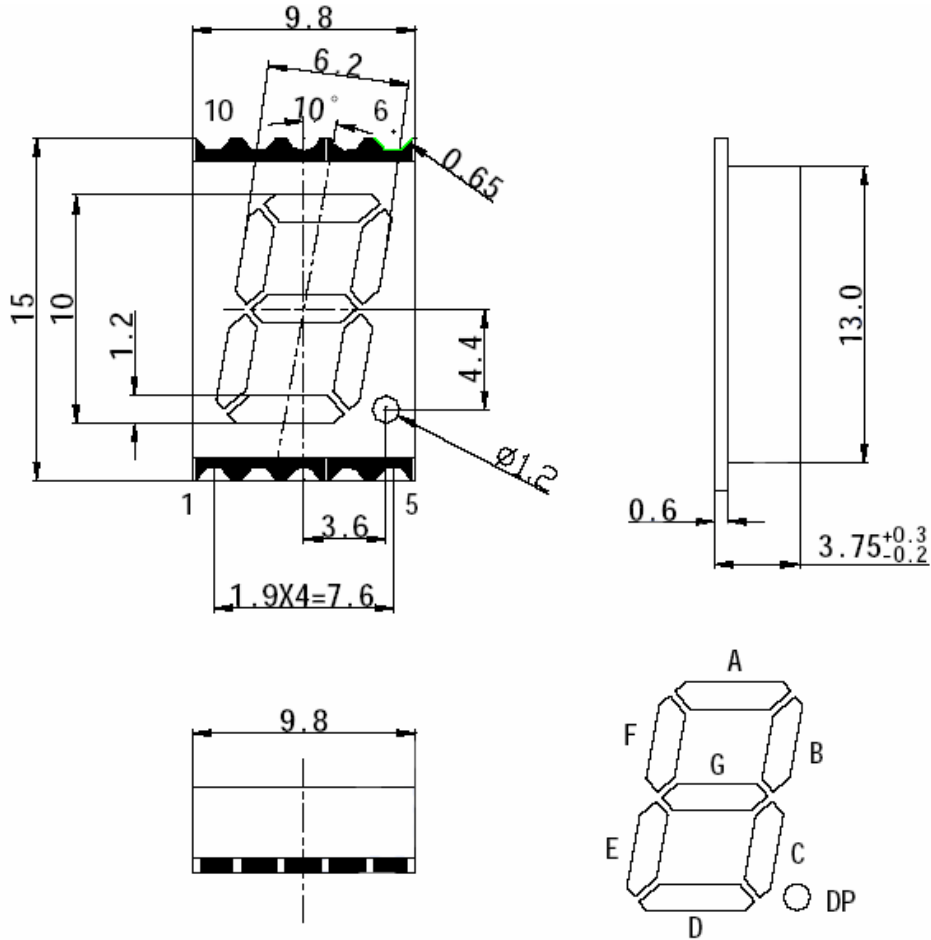

NOTES: All dimensions are in millimeters. Tolerances are ± 0.25 -mm (0.01") unless otherwise noted.

INTERNAL CIRCUIT DIAGRAM

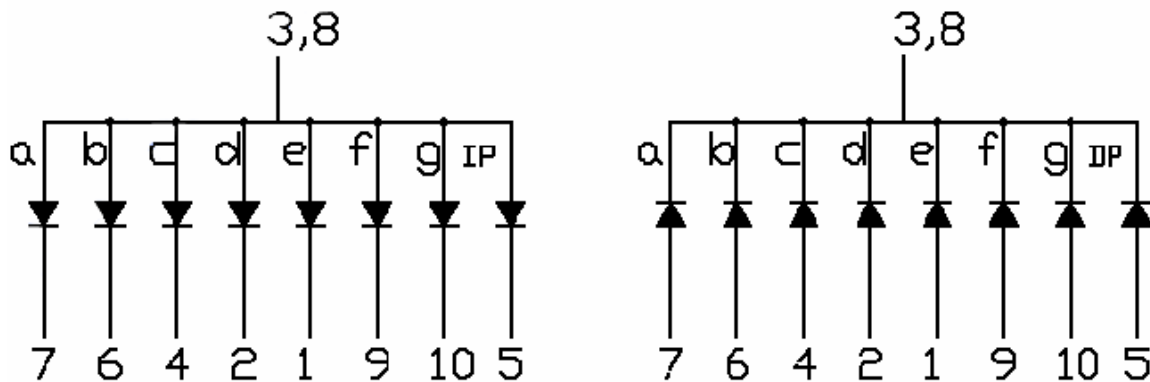

AVA TECHNOLOGY CO.

Selection Guide

Part No.	Dice	Lens Type	Iv (mcd) @10mA		Description
			Min.	Typ.	
ND39G1AYG-S	GREEN (InGaAlP)	WHITE DIFFUSED	11.08	12.04	Common Anode
ND39G1CYG-S	GREEN (InGaAlP)	WHITE DIFFUSED	11.08	12.04	Common Cathode

ABSOLUTE MAXIMUM RATING AT Ta = 25oC

PARAMETER	MAXIMUM RATING	UNIT
Power Dissipation Per Segment	105	mW
DC Forward Current	25	mA
Peak Forward Current	140	mA
Reverse Voltage Per Segment	5	V
Operating Temperature Range	-40 ⁰ C to +85 ⁰ C	

ELECTRICAL / OPTICAL CHARACTERISTICS AT Ta = 25°C

PARAMETER	SYMBOL	MIN.	TYP.	MAX.	UNIT	TEST CONDITION
Peak Emission Wavelength	λ_p		573		nm	I _F =20mA
Spectral Line Half-Width	$\Delta\lambda$		30		nm	I _F =20mA
Dominant Wavelength	λ_d		570		nm	I _F =20mA
Forward Voltage Per Segment	V _F		2.15	2.5	V	I _F =20mA
Reverse Current Per Segment	I _R			10	μ A	V _R =5V

Note: Luminous intensity is measured with a light sensor and filter combination that approximates the CIE (Commision Internationale De L'Eclairage) eye-response curve.

AVA TECHNOLOGY CO.

TYPICAL ELECTRICAL / OPTICAL CHARACTERISTIC CURVES

(25°C Ambient Temperature Unless Otherwise Noted)

RELATIVE INTENSITY vs WAVELENGTH

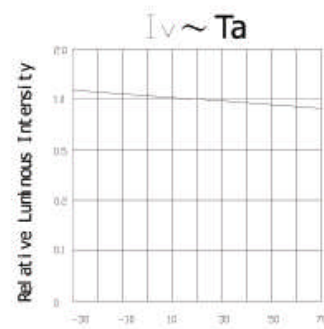
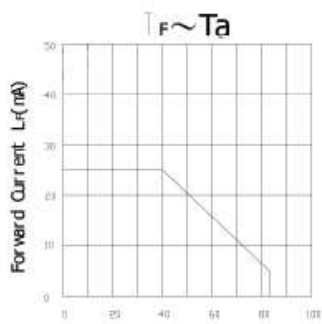
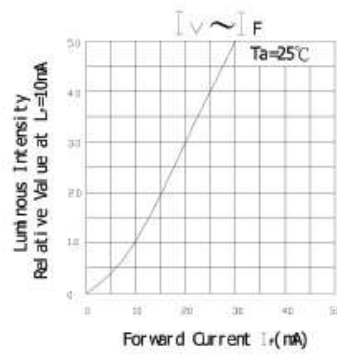
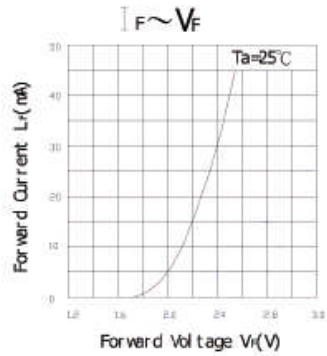
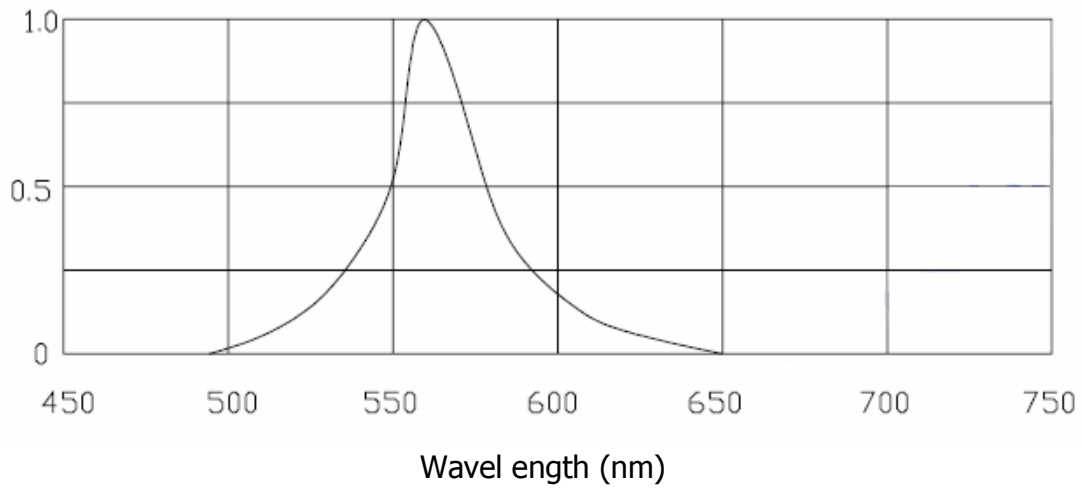

Ambient Temperature T_a (°C)

Ambient Temperature T_a (°C)

AVA TECHNOLOGY CO.

THE CHIP ON BOARD OR SMT Reflow Soldering Instructions

Number of reflow process shall be 2 times or less and cooling

Process to normal temperature is required between first and

Second soldering process.

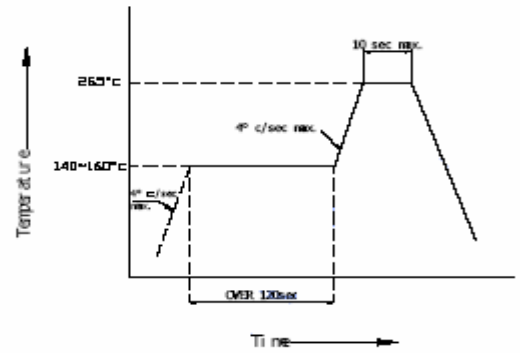
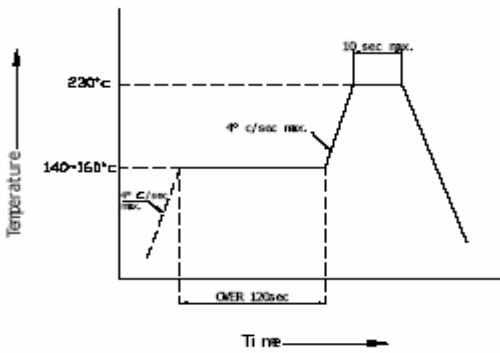

Recommended Soldering Pattern

(Units:mm)

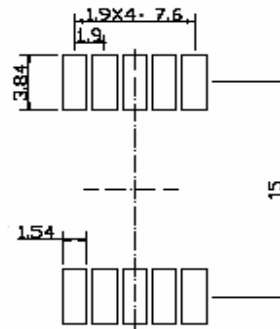

Tape Specifications

(Units:mm)

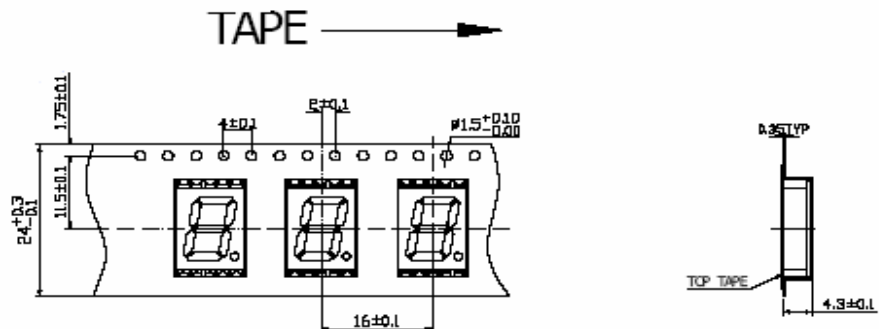

Remarks:

If special sorting is required (e.g. binning based on forward voltage, luminous intensity, or wavelength), the typical accuracy of the sorting process is as follow:

1. Wavelength: +/-1nm
2. Luminous Intensity: +/-15%
3. Forward Voltage: +/-0.1V

Note: Accuracy may depend on the sorting parameters.