

M52749FP

BUS Controlled 3ch Video Pre-amp for CRT Display Monitor

REJ03F0194-0201

Rev.2.01

Mar 31, 2008

Description

M52749FP is semiconductor integrated circuit for CRT display monitor.

It includes OSD blanking, OSD mixing, retrace blanking, wide band amplifier, brightness control, main/sub contrast and OSD adjust function.

Features

- Frequency Band Width: RGB 180 MHz (3 V_{P,P} at -3 dB)
OSD 80 MHz
- Input: RGB 0.7 V_{P,P} (typ.)
OSD 3 V_{P,P} min. (positive)
BLK (for OSD) 3 V_{P,P} min. (positive)
Retrace BLK 3 V_{P,P} min. (positive)
- Output: RGB 5.5 V_{P,P} (max.)
OSD 3.5 V_{P,P} (max.)
- Main contrast, sub contrast, OSD adjust and 5ch D/A OUT can be controlled by I²C BUS.

Application

CRT display monitor

Recommended Operating Conditions

Supply voltage range: 11.5 V to 12.5 V (V3, V8, V12, V42)

4.5 V to 5.5 V (V19)

Rated supply voltage: 12.0 V (V3, V8, V12, V42)

5.0 V (V19)

Major Specification

BUS controlled 3ch video pre-amp with OSD mixing function and retrace blanking function

Block Diagram

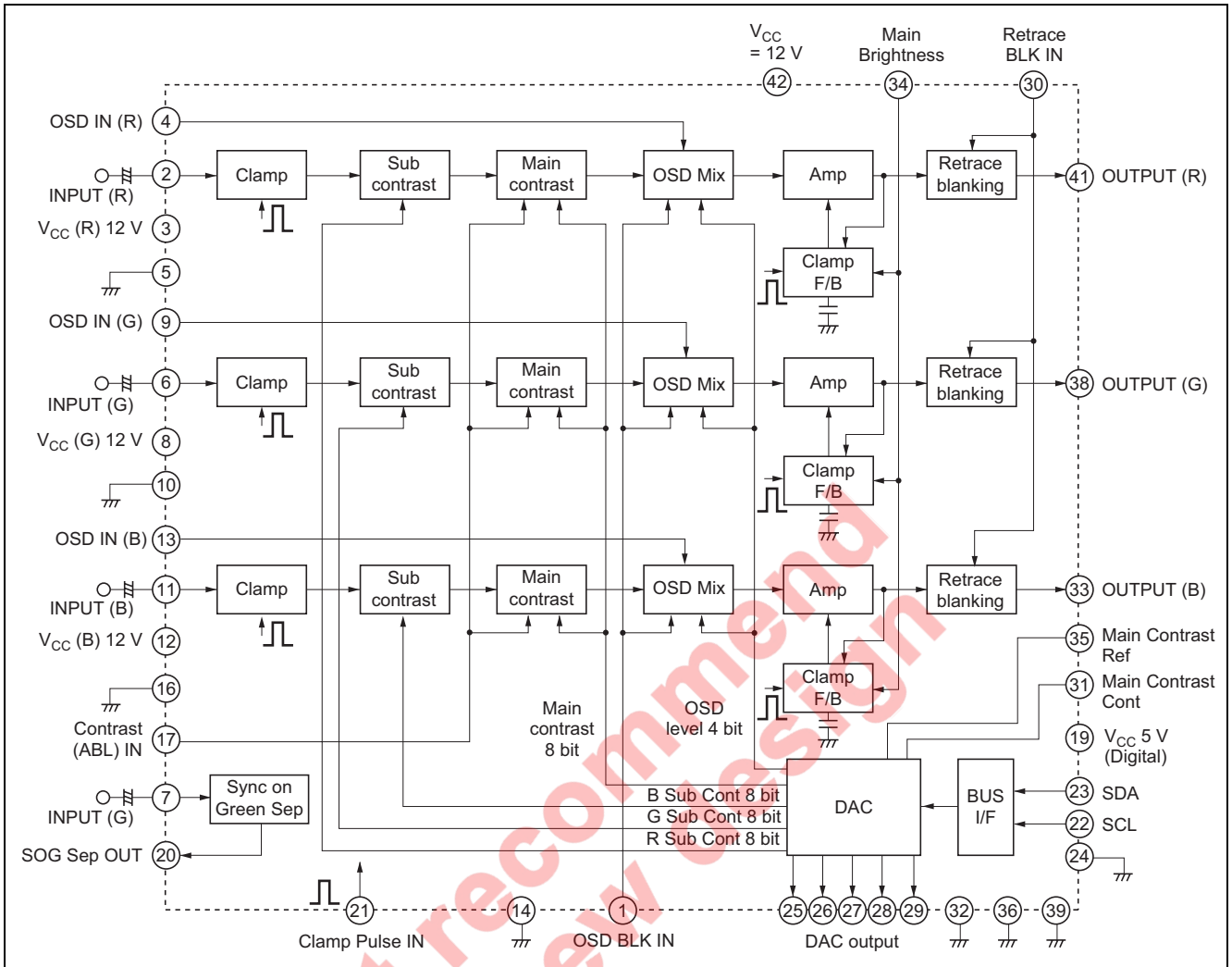

Pin Arrangement

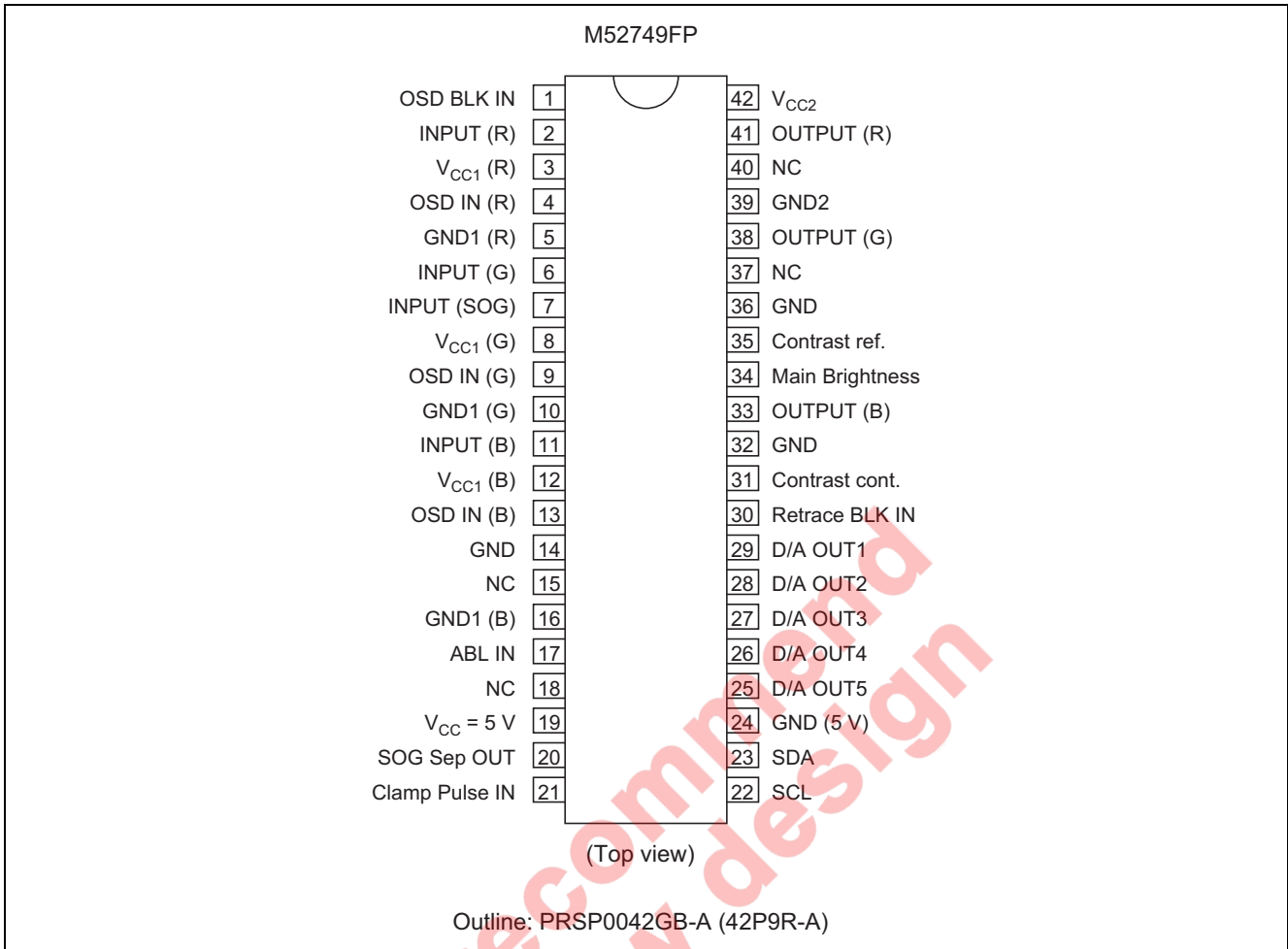

Absolute Maximum Ratings

(Ta = 25°C)

Item	Symbol	Ratings	Unit
Supply voltage (Pin 3, 8, 12, 42)	V _{CC12}	13.0	V
Supply voltage (Pin 19)	V _{CC5}	6.0	V
Power dissipation	P _d	2900	mW
Ambient temperature	T _{opr}	-20 to +75	°C
Storage temperature	T _{stg}	-40 to +150	°C
Recommended supply ₁₂	V _{opr12}	12.0	V
Recommended supply ₅	V _{opr5}	5.0	V
Voltage range ₁₂	V _{opr'12}	11.5 to 12.5 (Typ 12.0)	V
Voltage range ₅	V _{opr'5}	4.5 to 5.5 (Typ 5.0)	V

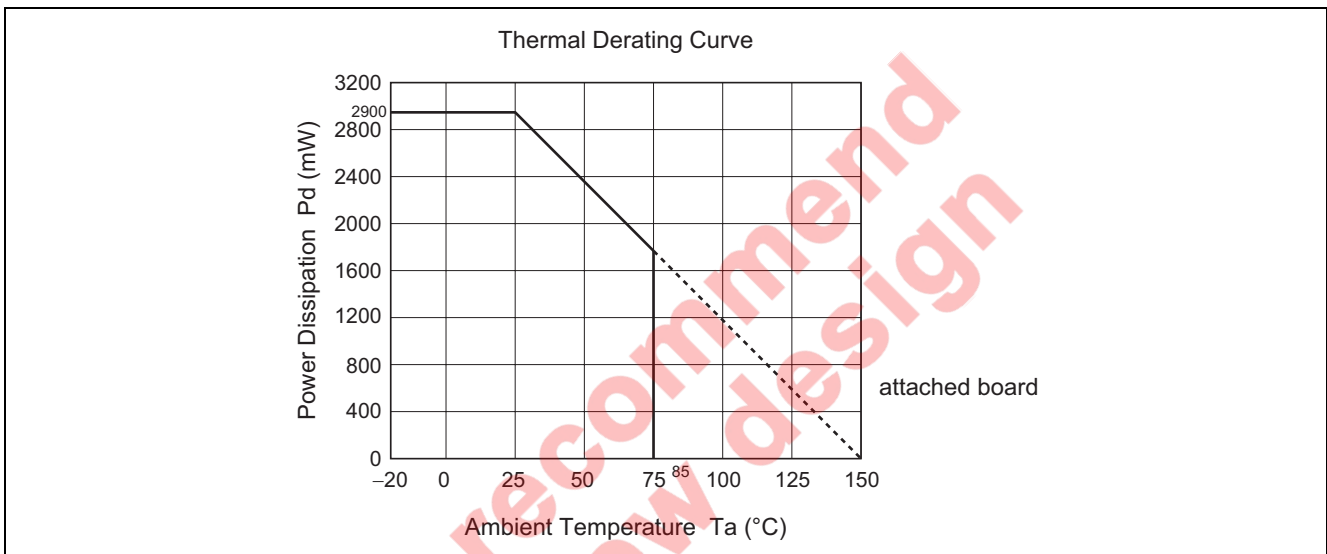

BUS Control Table

(1) Slave address:

D7	D6	D5	D4	D3	D2	D1	R/W	
1	0	0	0	1	0	0	0	= 88H

(2) Each function's sub address:

No.	Function	Bit	Sub Add.	Data Byte (Up: Bit, Information Down: Preset)							
				D7	D6	D5	D4	D3	D2	D1	D0
1	Main contrast	8	00H	A07	A06	A05	A04	A03	A02	A01	A00
				0	1	0	0	0	0	0	0
2	Sub contrast R	8	01H	A17	A16	A15	A14	A13	A12	A11	A10
				1	0	0	0	0	0	0	0
3	Sub contrast G	8	02H	A27	A26	A25	A24	A23	A22	A21	A20
				1	0	0	0	0	0	0	0
4	Sub contrast B	8	03H	A37	A36	A35	A34	A33	A32	A31	A30
				1	0	0	0	0	0	0	0
5	OSD level	4	04H	—	—	—	—	A43	A42	A41	A40
				0	0	0	0	1	0	0	0
6	D/A OUT1	8	06H	A67	A66	A65	A64	A63	A62	A61	A60
				1	0	0	0	0	0	0	0
7	D/A OUT2	8	07H	A77	A76	A75	A74	A73	A72	A71	A70
				1	0	0	0	0	0	0	0
8	D/A OUT3	8	08H	A87	A86	A85	A84	A83	A82	A81	A80
				1	0	0	0	0	0	0	0
9	D/A OUT4	8	09H	A97	A96	A95	A94	A93	A92	A91	A90
				1	0	0	0	0	0	0	0
10	D/A OUT5	8	0AH	AA7	AA6	AA5	AA4	AA3	AA2	AA1	AA0
				1	0	0	0	0	0	0	0

Not recommended for new designs

I²C BUS Control Section SDA, SCL Characteristics

Item	Symbol	Min.	Max.	Unit
Min. input LOW voltage	V_{IL}	-0.5	1.5	V
Max. input HIGH voltage	V_{IH}	3.0	5.5	V
SCL clock frequency	f_{SCL}	0	400	kHz
Time the bus must be free before a new transmission can start	t_{BUF}	1.3	—	μ s
Hold time start condition. After this period the first clock pulse is generated	$t_{HD:STA}$	0.6	—	μ s
The LOW period of the clock	t_{LOW}	1.3	—	μ s
The HIGH period of the clock	t_{HIGH}	0.6	—	μ s
Set up time for start condition (Only relevant for a repeated start condition)	$t_{SU:STA}$	0.6	—	μ s
Hold time DATA	$t_{HD:DAT}$	0.1	—	μ s
Set-up time DATA	$t_{SU:DAT}$	100	—	ns
Rise time of both SDA and SCL lines	t_r	—	300	ns
Fall time of both SDA and SCL lines	t_f	—	300	ns
Set-up time for stop condition	$t_{SU:STO}$	0.6	—	μ s

Timing Chart

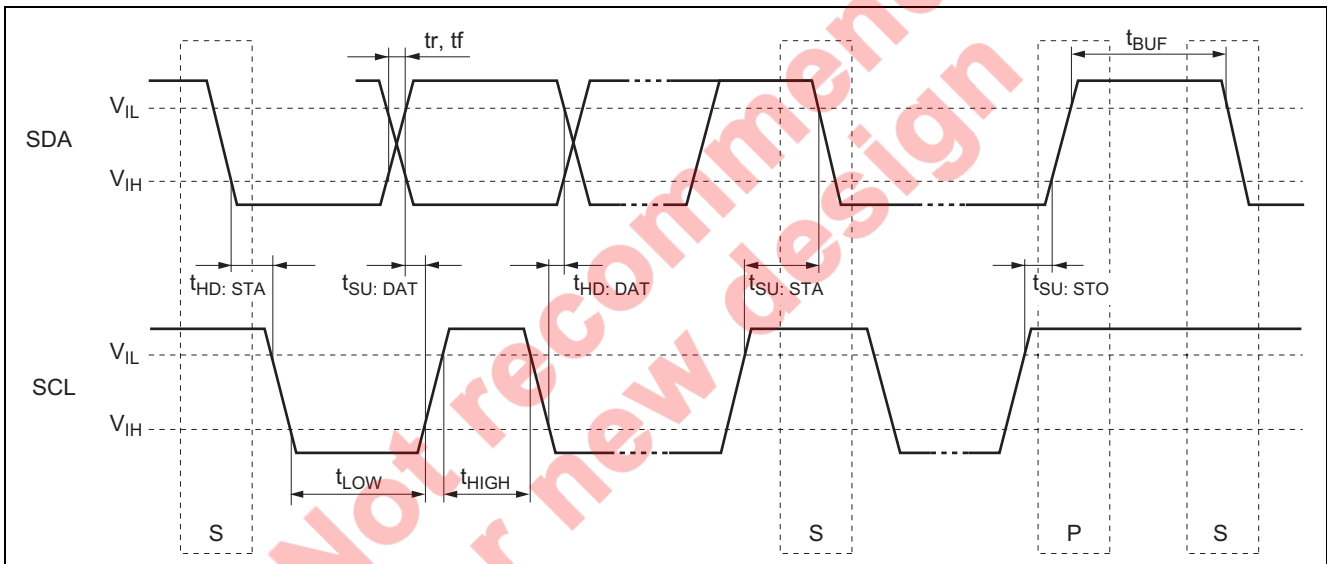

Electrical Characteristics

(V_{CC} = 12 V, 5 V; Ta = 25°C unless otherwise specified)

Item	Symbol	Limits			Unit	Test Point (s)	Input							CTL Voltage		BUS CTL (H)													
		Min.	Typ.	Max.			2, 6, 11 RGB in	1 OSD BLK	4, 9, 13 OSD in	21 CP in	30 ReT BLK	7 SOG in	34 Bright	17 ABL	00H Main Cont	01H Sub Cont 1	02H Sub Cont 2	03H Sub Cont 3	04H OSD Adj	06H D/A OUT 1	07H D/A OUT 2	08H D/A OUT 3	09H D/A OUT 4	0AH D/A OUT 5					
Circuit current1	I _{CC1}	—	110	130	mA	I _A	a	a	a	b SG5	a	a	4.0	5.0	FFH 255	FFH 255	FFH 255	FFH 255	00H 0	FFH 255	FFH 255	FFH 255	FFH 255	FFH 255	FFH 255	FFH 255	FFH 255	FFH 255	
Circuit current2	I _{CC2}	—	18	22	mA	I _B	a	a	a	b SG5	a	a	4.0	5.0															
Output dynamic range	V _{omax}	6.0	8.0	—	V _{P-P}	OUT	b SG2	a	a	b SG5	a	a	Variable	5.0															
Maximum input	V _{imax}	1.6	—	—	V _{P-P}	IN OUT	b SG2 Variable	a	a	b SG5	a	a	2.0	5.0	64H 100														
Maximum gain	G _V	16.5	17.7	19.4	dB	OUT	b SG1	a	a	b SG5	a	a	2.0	5.0	FFH 255														
Relative maximum gain	ΔG _V	0.8	1.0	1.2	—	—	—	—	—	—	—	—	—	—	—														
Main contrast control characteristics1	V _{C1}	15.5	17.0	18.5	dB	OUT	b SG1	a	a	b SG5	a	a	2.0	5.0	C8H 200														
Main contrast control relative characteristics1	ΔV _{C1}	0.8	1.0	1.2	—	—	—	—	—	—	—	—	—	—	—														
Main contrast control characteristics2	V _{C2}	9.0	10.5	12.0	dB	OUT	b SG1	a	a	b SG5	a	a	2.0	5.0	64H 100														
Main contrast control relative characteristics2	ΔV _{C2}	0.8	1.0	1.2	—	—	—	—	—	—	—	—	—	—	—														
Main contrast control characteristics3	V _{C3}	0.2	0.4	0.6	V _{P-P}	OUT	b SG1	a	a	b SG5	a	a	2.0	5.0	14H 20														
Main contrast control relative characteristics3	ΔV _{C3}	0.8	1.0	1.2	—	—	—	—	—	—	—	—	—	—	—														
Sub contrast control characteristics1	V _{SC1}	15.5	17.0	18.5	dB	OUT	b SG1	a	a	b SG5	a	a	2.0	5.0	FFH 255	C8H 200	C8H 200	C8H 200											
Sub contrast control relative characteristics1	ΔV _{SC1}	0.8	1.0	1.2	—	—	—	—	—	—	—	—	—	—	—														
Sub contrast control characteristics2	V _{SC2}	10.5	12.0	13.5	dB	OUT	b SG1	a	a	b SG5	a	a	2.0	5.0	FFH 255	64H 100	64H 100	64H 100											
Sub contrast control relative characteristics2	ΔV _{SC2}	0.8	1.0	1.2	—	—	—	—	—	—	—	—	—	—	—														
Sub contrast control characteristics3	V _{SC3}	0.7	1.2	1.5	V _{P-P}	OUT	b SG1	a	a	b SG5	a	a	2.0	5.0	FFH 255	14H 20	14H 20	14H 20											
Sub contrast control relative characteristics3	ΔV _{SC3}	0.8	1.0	1.2	—	—	—	—	—	—	—	—	—	—	—														
Main/sub contrast control characteristics	VMSC	3.4	4.0	4.6	V _{P-P}	OUT	b SG1	a	a	b SG5	a	a	2.0	5.0	C8H 200	C8H 200	C8H 200	C8H 200											
Main/sub contrast control relative characteristics	ΔVMSC	0.8	1.0	1.2	—	—	—	—	—	—	—	—	—	—	—														
ABL control characteristics1	ABL1	4.6	5.4	6.2	V _{P-P}	OUT	b SG1	a	a	b SG5	a	a	2.0	4.0	FFH 255	FFH 255	FFH 255	FFH 255											
ABL control relative characteristics1	ΔABL1	0.8	1.0	1.2	—	—	—	—	—	—	—	—	—	—	—														
ABL control characteristics2	ABL2	2.3	2.8	3.3	V _{P-P}	OUT	b SG1	a	a	b SG5	a	a	2.0	2.0															
ABL control relative characteristics2	ΔABL2	0.8	1.0	1.2	—	—	—	—	—	—	—	—	—	—	—														

Item	Symbol	Limits			Unit	Test Point (s)	Input							CTL Voltage		BUS CTL (H)									
		Min.	Typ.	Max.			2, 6, 11 RGB in	1 OSD BLK	4, 9, 13 OSD in	21 CP in	30 ReT BLK	7 SOG in	34 Bright	17 ABL	00H Main Cont	01H Sub Cont 1	02H Sub Cont 2	03H Sub Cont 3	04H OSD Adj	06H D/A OUT 1	07H D/A OUT 2	08H D/A OUT 3	09H D/A OUT 4	0AH D/A OUT 5	
Brightness control characteristics1	V _{B1}	3.6	4.0	4.4	V	OUT	a	a	a	b SG5	a	a	4.0	5.0	FFH 255	FFH 255	FFH 255	FFH 255	00H 0	FFH 255	FFH 255	FFH 255	FFH 255	FFH 255	FFH 255
Brightness control relative characteristics1	ΔV _{B1}	-0.3	0	0.3	V	—	—	—	—	—	—	—	—	—											
Brightness control characteristics2	V _{B2}	1.8	2.1	2.4	V	OUT	a	a	a	b SG5	a	a	2.0	5.0											
Brightness control relative characteristics2	ΔV _{B2}	-0.3	0	0.3	V	—	—	—	—	—	—	—	—	—											
Brightness control characteristics3	V _{B3}	0.9	1.1	1.3	V	OUT	a	a	a	b SG5	a	a	1.0	5.0											
Brightness control relative characteristics3	ΔV _{B3}	-0.3	0	0.3	V	—	—	—	—	—	—	—	—	—											
Frequency characteristics1 (f = 50 MHz)	F _{C1}	-2.0	0	2.5	dB	OUT	b SG3	a	a	a 5V	a	a	Variable	5.0	Variable										
Frequency relative characteristics1 (f = 50 MHz)	ΔF _{C1}	-1.0	0	1.0	dB	—	—	—	—	—	—	—	—	—											
Frequency characteristics1 (f = 180 MHz)	F _{C1'}	-3.0	0	3.0	dB	OUT	b SG3	a	a	a 5V	a	a	Variable	5.0	Variable										
Frequency relative characteristics1 (f = 180 MHz)	ΔF _{C1'}	-1.0	0	1.0	dB	—	—	—	—	—	—	—	—	—											
Frequency characteristics2 (f = 180 MHz)	F _{C2}	-3.0	3.0	5.0	dB	OUT	b SG3	a	a	a 5V	a	a	Variable	5.0											
Frequency relative characteristics2 (f = 180 MHz)	ΔF _{C2}	-1.0	0	1.0	dB	—	—	—	—	—	—	—	—	—											
Crosstalk1 (f = 50 MHz)	C.T.1	—	-25	-20	dB	OUT (33) OUT (38)	2b SG3 6a 11a	a	a	a 5V	a	a	Variable	5.0	FFH 255										
Crosstalk1 (f = 180 MHz)	C.T.1'	—	-20	-15	dB	OUT (33) OUT (38)	2b SG3 6a 11a	a	a	a 5V	a	a	Variable	5.0											
Crosstalk2 (f = 50 MHz)	C.T.2	—	-25	-20	dB	OUT (33) OUT (41)	2a 6b SG3 11a	a	a	a 5V	a	a	Variable	5.0											
Crosstalk2 (f = 180 MHz)	C.T.2'	—	-20	-15	dB	OUT (33) OUT (41)	2a 6b SG3 11a	a	a	a 5V	a	a	Variable	5.0											
Crosstalk3 (f = 50 MHz)	C.T.3	—	-25	-20	dB	OUT (38) OUT (41)	2a 6a 11b SG3	a	a	a 5V	a	a	Variable	5.0											
Crosstalk3 (f = 180 MHz)	C.T.3'	—	-20	-15	dB	OUT (38) OUT (41)	2a 6a 11b SG3	a	a	a 5V	a	a	Variable	5.0											
Pulse characteristics1 (3 V _{P-P})	Tr	—	2.0	2.8	ns	OUT	b SG1	a	a	b SG5	a	a	Variable	5.0	Variable										
Pulse characteristics2 (3 V _{P-P})	Tf	—	2.0	2.8	ns	OUT	b SG1	a	a	b SG5	a	a	Variable	5.0	Variable										
Clamp pulse threshold voltage	V _{thCP}	1.0	1.5	2.0	V	OUT	b SG1	a	a	b SG5 Variable	a	a	2.0	5.0	FFH 255										
Clamp pulse minimum width	WCP	0.2	—	—	μs	OUT	b SG1	a	a	b SG5 Variable	a	a	2.0	5.0											
OSD pulse characteristics1	OTr	—	3.0	6.0	ns	OUT	a	a	b SG6	b SG5	a	a	2.0	5.0											
OSD pulse characteristics2	OTf	—	3.0	6.0	ns	OUT	a	a	b SG6	b SG5	a	a	2.0	5.0											

Item	Symbol	Limits			Unit	Test Point (s)	Input						CTL Voltage		BUS CTL (H)										
		Min.	Typ.	Max.			2, 6, 11 RGB in	1 OSD BLK	4, 9, 13 OSD in	21 CP in	30 ReT BLK	7 SOG in	34 Bright	17 ABL	00H Main Cont	01H Sub Cont 1	02H Sub Cont 2	03H Sub Cont 3	04H OSD Adj	06H D/A OUT 1	07H D/A OUT 2	08H D/A OUT 3	09H D/A OUT 4	0AH D/A OUT 5	
OSD adjust control characteristics1	Oaj1	2.8	3.5	4.2	V _{p,p}	OUT	a	b SG6	b SG6	b SG5	a	a	2.0	5.0	FFH 255	FFH 255	FFH 255	FFH 255	0FH 15	FFH 255	FFH 255	FFH 255	FFH 255	FFH 255	FFH 255
OSD adjust control relative characteristics1	ΔOaj1	0.8	1.0	1.2	—	—	—	—	—	—	—	—	—	—	—	—	—	—	—	—	—	—	—	—	—
OSD adjust control characteristics2	Oaj2	2.25	2.8	3.35	V _{p,p}	OUT	a	b SG6	b SG6	b SG5	a	a	2.0	5.0	—	—	—	—	08H 8	—	—	—	—	—	—
OSD adjust control relative characteristics2	ΔOaj2	0.8	1.0	1.2	—	—	—	—	—	—	—	—	—	—	—	—	—	—	—	—	—	—	—	—	—
OSD adjust control characteristics3	Oaj3	1.2	1.5	1.8	V _{p,p}	OUT	a	b SG6	b SG6	b SG5	a	a	2.0	5.0	—	—	—	—	00H 0	—	—	—	—	—	—
OSD adjust control relative characteristics3	ΔOaj3	0.8	1.0	1.2	—	—	—	—	—	—	—	—	—	—	—	—	—	—	—	—	—	—	—	—	—
OSD input threshold voltage	VthOSD	2.2	2.7	3.2	V	OUT	a	b SG6	b SG6 Variable	b SG5	a	a	2.0	5.0	—	—	—	—	08H 8	—	—	—	—	—	—
OSD BLK input threshold voltage	VthBLK	2.2	2.7	3.2	V	OUT	b SG1	b SG6 Variable	a	b SG5	a	a	2.0	5.0	—	—	—	—	00H 0	—	—	—	—	—	—
Retrace BLK characteristics1	HBLK1	—	0.3	0.6	V	OUT	a	a	a	b SG5	b SG7	a	2.0	5.0	—	—	—	—	—	—	—	—	—	—	—
Retrace BLK input threshold voltage	VthRET	1.0	1.5	2.0	V	OUT	a	a	a	b SG5	b SG7 Variable	a	2.0	5.0	—	—	—	—	—	—	—	—	—	—	—
SOG input maximum noise voltage	SS-NV	—	—	0.03	V _{p,p}	SonG IN SyncOUT	a	a	a	a	a	b SG4 Variable	2.0	5.0	—	—	—	—	—	—	—	—	—	—	—
SOG minimum input voltage	SS-SV	0.2	—	—	V _{p,p}	SonG IN SyncOUT	a	a	a	a	a	b SG4 Variable	2.0	5.0	—	—	—	—	—	—	—	—	—	—	—
Sync output high level	VSH	4.5	4.9	5.0	V	Sync OUT	a	a	a	a	a	b SG4	2.0	5.0	—	—	—	—	—	—	—	—	—	—	—
Sync output low level	VSL	0	0.3	0.6	V	Sync OUT	a	a	a	a	a	b SG4	2.0	5.0	—	—	—	—	—	—	—	—	—	—	—
Sync output delay time1	TDS-F	0	60	90	ns	Sync OUT	a	a	a	a	a	b SG4	2.0	5.0	—	—	—	—	—	—	—	—	—	—	—
Sync output delay time2	TDS-R	0	60	90	ns	Sync OUT	a	a	a	a	a	b SG4	2.0	5.0	—	—	—	—	—	—	—	—	—	—	—
D/A H output voltage	VOH	4.5	5.0	5.5	V _{DC}	D/A OUT	a	a	a	a	a	a	2.0	5.0	FFH 255	FFH 255	FFH 255	FFH 255	00H 0	FFH 255	FFH 255	FFH 255	FFH 255	FFH 255	FFH 255
D/A L output voltage	VOL	0	0.5	1.0	V _{DC}	D/A OUT	a	a	a	a	a	a	2.0	5.0	—	—	—	—	—	00H 0	00H 0	00H 0	00H 0	00H 0	00H 0
D/A OUT input current	IA-	0.18	—	—	mA	D/A OUT	a	a	a	a	a	a	2.0	5.0	00H 0	00H 0	00H 0	00H 0	00H 0	00H 0	00H 0	00H 0	00H 0	00H 0	00H 0
D/A OUT output current	IA+	—	—	1.0	mA	D/A OUT	a	a	a	a	a	a	2.0	5.0	—	—	—	—	—	—	—	—	—	—	—
D/A nonlinearity	DNL	-1.0	—	1.0	LSB	D/A OUT	a	a	a	a	a	a	2.0	5.0	FFH 255	FFH 255	FFH 255	FFH 255	00H 0	Vari able	Vari able	Vari able	Vari able	Vari able	Vari able

Electrical Characteristics Test Method

I_{CC1} Circuit Current1

Measuring conditions are as listed in supplementary Table.

Measured with a current meter at test point I_A.

I_{CC2} Circuit Current2

Measuring conditions are as listed in supplementary Table.

Measured with a current meter at test point I_B.

V_{omax} Output Dynamic Range

Decrease V₃₄ gradually, and measure the voltage when the bottom of waveform output is distorted. The voltage is called VOL.

Next, increase V₃₄ gradually, and measure the voltage when the top of waveform output is distorted. The voltage is called VOH.

Voltage V_{omax} is calculated by the equation below:

$$V_{omax} = VOH - VOL$$

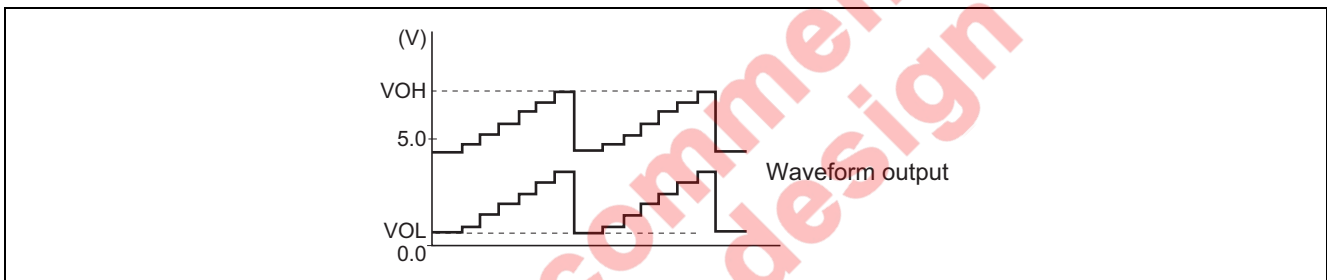

V_{imax} Maximum Input

Increase the input signal (SG2) amplitude gradually, starting from 700 mV_{p-p}. Measure the amplitude of the input signal when the output signal starts becoming distorted.

G_v Maximum Gain

Input SG1, and read the amplitude output at OUT (33, 38, 41). The amplitude is called VOUT (33, 38, 41).

Maximum gain G_v is calculated by the equation below:

$$G_v = 20 \log \frac{VOUT}{0.7} \text{ (dB)}$$

ΔG_v Relative Maximum Gain

Relative maximum gain ΔG_v is calculated by the equation below:

$$\begin{aligned} \Delta G_v &= VOUT(33) / VOUT(38), \\ &VOUT(38) / VOUT(41), \\ &VOUT(41) / VOUT(33) \end{aligned}$$

V_{C1} Main Contrast Control Characteristics1

Measuring the amplitude output at OUT (33, 38, 41). The measured value is called VOUT (33, 38, 41). Main contrast control characteristics V_{C1} is calculated by the equation below:

$$V_{C1} = 20 \log \frac{V_{OUT}}{0.7} \quad (\text{dB})$$

ΔV_{C1} Main Contrast Control Relative Characteristics1

Relative characteristics ΔV_{C1} is calculated by the equation below:

$$\begin{aligned} \Delta V_{C1} &= V_{OUT} (33) / V_{OUT} (38) , \\ &V_{OUT} (38) / V_{OUT} (41) , \\ &V_{OUT} (41) / V_{OUT} (33) \end{aligned}$$

V_{C2} Main Contrast Control Characteristics2

Measuring condition and procedure are the same as described in V_{C1}.

ΔV_{C2} Main Contrast Control Relative Characteristics2

Measuring condition and procedure are the same as described in ΔV_{C1}.

V_{C3} Main Contrast Control Characteristics3

Measure the amplitude output at OUT (33, 38, 41). The measured value is called VOUT (33, 38, 41).

ΔV_{C3} Main Contrast Control Relative Characteristics3

Measuring condition and procedure are the same as described in ΔV_{C1}.

V_{SC1} Sub Contrast Control Characteristics1

Measure the amplitude output at OUT (33, 38, 41). The measured value is called VOUT (33, 38, 41).

Sub contrast control characteristics V_{SC1} is calculated by the equation below:

$$V_{SC1} = 20 \log \frac{V_{OUT}}{0.7} \quad (\text{dB})$$

ΔV_{SC1} Sub Contrast Control Relative Characteristics1

Relative characteristics ΔV_{SC1} is calculated by the equation below:

$$\begin{aligned} \Delta V_{SC1} &= V_{OUT} (33) / V_{OUT} (38), \\ &V_{OUT} (38) / V_{OUT} (41), \\ &V_{OUT} (41) / V_{OUT} (33). \end{aligned}$$

V_{SC2} Sub Contrast Control Characteristics2

Measuring condition and procedure are the same as described in V_{SC1}.

ΔV_{SC2} Sub Contrast Control Relative Characteristics2

Measuring condition and procedure are the same as described in ΔV_{SC1}.

V_{SC3} Sub Contrast Control Characteristics3

Measure the amplitude output at OUT (33, 38, 41). The measured value is called VOUT (33, 38, 41).

ΔV_{SC3} Sub Contrast Control Relative Characteristics3

Measuring condition and procedure are the same as described in ΔV_{SC1}.

VMSC Main/sub Contrast Control Characteristics

Measure the amplitude output at OUT (33, 38, 41). The measured value is called VMSC.

 Δ VMSC Main/sub Contrast Control Relative Characteristics

Relative characteristics Δ VMSC is calculated by the equation below:

$$\begin{aligned}\Delta\text{VMSC} &= \text{VOUT (33)} / \text{VOUT (38)}, \\ &\text{VOUT (38)} / \text{VOUT (41)}, \\ &\text{VOUT (41)} / \text{VOUT (33)}.\end{aligned}$$

ABL1 ABL Control Characteristics1

Measure the amplitude output at OUT (33, 38, 41). The measured value is called VOUT (33, 38, 41), and is treated as ABL1.

 Δ ABL1 ABL Control Relative Characteristics1

Relative characteristics Δ ABL1 is calculated by the equation below:

$$\begin{aligned}\Delta\text{ABL1} &= \text{VOUT (33)} / \text{VOUT (38)}, \\ &\text{VOUT (38)} / \text{VOUT (41)}, \\ &\text{VOUT (41)} / \text{VOUT (33)}.\end{aligned}$$

ABL2 ABL Control Characteristics2

Measuring condition and procedure are the same as described in ABL1.

 Δ ABL2 ABL Control Relative Characteristics2

Measuring condition and procedure are the same as described in Δ ABL1.

 V_{B1} Brightness Control Characteristics1

Measure the DC voltage at OUT (33, 38, 41) with a voltmeter. The measured value is called VOUT (33, 38, 41), and is treated as V_{B1} .

 ΔV_{B1} Brightness Control Relative Characteristics1

Relative characteristics ΔV_{B1} is calculated by the difference in the output between the channels.

$$\begin{aligned}\Delta V_{B1} &= \text{VOUT (33)} - \text{VOUT (38)}, \\ &\text{VOUT (38)} - \text{VOUT (41)}, \\ &\text{VOUT (41)} - \text{VOUT (33)}.\end{aligned}$$

 V_{B2} Brightness Control Characteristics2

Measuring condition and procedure are the same as described in V_{B1} .

 ΔV_{B2} Brightness Control Relative Characteristics2

Measuring condition and procedure are the same as described in ΔV_{B1} .

 V_{B3} Brightness Control Characteristics3

Measuring condition and procedure are the same as described in V_{B1} .

 ΔV_{B3} Brightness Control Relative Characteristics3

Measuring condition and procedure are the same as described in ΔV_{B1} .

F_{C1} Frequency Characteristics1 (f = 50 MHz)

First, SG3 to 1 MHz is as input signal. Input a resistor that is about 2 kΩ to offer the voltage at input pins (2, 6, 11) in order that the bottom of input signal is 2.5 V.

Control the main contrast in order that the amplitude of sine wave output is 4.0 V_{P-P}.

Control the brightness in order that the bottom of sine wave output is 2.0 V_{P-P}.

By the same way, measure the output amplitude when SG3 to 50 MHz is as input signal.

The measured value is called VOUT (33, 38, 41). Frequency characteristics F_{C1} (33, 38, 41) is calculated by the equation below:

$$F_{C1} = 20 \log \frac{V_{OUT} V_{P-P}}{\text{Output amplitude when inputted SG3 (1 MHz): } 4.0 V_{P-P}} \quad (\text{dB})$$

ΔF_{C1} Frequency Relative Characteristics1 (f = 50 MHz)

Relative characteristics ΔF_{C1} is calculated by the difference in the output between the channels.

F_{C1'} Frequency Characteristics1 (f = 180 MHz)

Measuring condition and procedure are the same as described in F_{C1}, expect SG3 to 180 MHz.

ΔF_{C1'} Frequency Relative Characteristics1 (f = 180 MHz)

Relative characteristics ΔF_{C1'} is calculated by the difference in the output between the channels.

F_{C2} Frequency Characteristics2 (f = 180 MHz)

SG3 to 1 MHz is as input signal. Control the main contrast in order that the amplitude of sine wave output is 1.0 V_{P-P}. By the same way, measure the output amplitude when SG3 to 150 MHz is as input signal.

The measured value is called VOUT (33, 38, 41).

Frequency characteristics F_{C2} (33, 38, 41) is calculated by the equation below:

$$F_{C2} = 20 \log \frac{V_{OUT} V_{P-P}}{\text{Output amplitude when inputted SG3 (1 MHz): } 4.0 V_{P-P}} \quad (\text{dB})$$

ΔF_{C2} Frequency Relative Characteristics2 (f = 180 MHz)

Relative characteristics ΔF_{C2} is calculated by the difference in the output between the channels.

C.T.1 Crosstalk1 (f = 50 MHz)

Input SG3 (50 MHz) to pin 2 only, and then measure the waveform amplitude output at OUT (33, 38, 41). The measured value is called VOUT (33, 38, 41). Crosstalk C.T.1 is calculated by the equation below:

$$C.T.1 = 20 \log \frac{V_{OUT} (33, 38)}{V_{OUT} (41)} \quad (\text{dB})$$

C.T.1' Crosstalk1 (f = 180 MHz)

Measuring condition and procedure are the same as described in C.T.1, expect SG3 to 180 MHz.

C.T.2 Crosstalk2 (f = 50 MHz)

Input SG3 (50 MHz) to pin 6 only, and then measure the waveform amplitude output at OUT (33, 38, 41).

The measured value is called VOUT (33, 38, 41). Crosstalk C.T.2 is calculated by the equation below:

$$C.T.2 = 20 \log \frac{V_{OUT} (33, 41)}{V_{OUT} (38)} \quad (\text{dB})$$

C.T.2' Crosstalk2 (f = 180 MHz)

Measuring condition and procedure are the same as described in C.T.2, expect SG3 to 180 MHz.

C.T.3 Crosstalk3 (f = 50 MHz)

Input SG3 (50 MHz) to pin 11 only, and then measure the waveform amplitude output at OUT (33, 38, 41).

The measured value is called VOUT (33, 38, 41). Crosstalk C.T.3 is calculated by the equation below:

$$C.T.3 = 20 \log \frac{VOUT(38, 41)}{VOUT(33)} \quad (\text{dB})$$

C.T.3' Crosstalk3 (f = 180 MHz)

Measuring condition and procedure are the same as described in C.T.3, expect SG3 to 180 MHz.

Tr Pulse Characteristics1 (3 V_{P-P})

Control the main contrast (00H) in order that the amplitude of output signal is 3.0 V_{P-P}.

Control the brightness (V34) in order that the Black level of output signal is 2.0 V.

Measure the time needed for the input pulse to rise from 10% to 90% (Tr1) and for the output pulse to rise from 10% to 90% (Tr2) with an active probe.

Pulse characteristics Tr is calculated by the equations below:

$$Tr = \sqrt{(Tr2)^2 - (Tr1)^2} \quad (\text{ns})$$

Tf Pulse Characteristics2 (3 V_{P-P})

Measure the time needed for the input pulse to fall from 90% to 10% (Tf1) and for the output pulse to fall from 90% to 10% (Tf2) with an active probe.

Pulse characteristics Tf is calculated by the equations below:

$$Tf = \sqrt{(Tf2)^2 - (Tf1)^2} \quad (\text{ns})$$

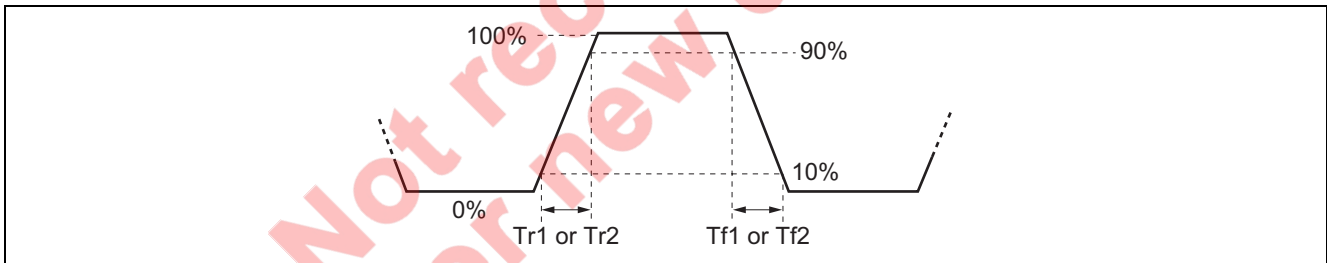
**VthCP Clamp Pulse Threshold Voltage**

Turn down the SG5 input level gradually from 5.0 V_{P-P}, monitoring the waveform output.

Measure the top level of input pulse when the output pedestal voltage turn decrease with unstable.

WCP Clamp Pulse Minimum Width

Decrease the SG5 pulse width gradually from 0.5 μs, monitoring the output. Measure the SG5 pulse width (a point of 1.5 V) when the output pedestal voltage turn decrease with unstable.

OTr OSD Pulse Characteristics1

Measure the time needed for the output pulse to rise from 10% to 90% (OTr) with an active probe.

OTf OSD Pulse Characteristics2

Measure the time needed for the output pulse to fall from 90% to 10% (OTf) with an active probe.

Oaj1 OSD Adjust Control Characteristics1

Measure the amplitude output at OUT (33, 38, 41). The measured value is called VOUT (33, 38, 41), and is treated as Oaj1.

ΔOaj1 OSD Adjust Control Relative Characteristics1

Relative characteristics ΔOaj1 is calculated by the equation below:

$$\Delta Oaj1 = \frac{VOUT(33)}{VOUT(38)},$$
$$\frac{VOUT(38)}{VOUT(41)},$$
$$\frac{VOUT(41)}{VOUT(33)}.$$

Oaj2 OSD Adjust Control Characteristics2

Measuring condition and procedure are the same as described in Oaj1.

ΔOaj2 OSD Adjust Control Relative Characteristics2

Measuring condition and procedure are the same as described in ΔOaj1.

Oaj3 OSD Adjust Control Characteristics3

Measuring condition and procedure are the same as described in Oaj1.

ΔOaj3 OSD Adjust Control Relative Characteristics3

Measuring condition and procedure are the same as described in ΔOaj1.

VthOSD OSD Input Threshold Voltage

Reduce the SG6 input level gradually, monitoring output. Measure the SG6 level when the output reaches 0 V.

The measured value is called VthOSD.

VthBLK OSD BLK Input Threshold Voltage

Confirm that output signal is being blanked by the SG6 at the time.

Monitoring to output signal, decreasing the level of SG6. Measure the top level of SG6 when the blanking period is disappeared. The measured value is called VthBLK.

HBLK1 Retrace BLK Characteristics1

Measure the amplitude output is blanked by the SG7 at OUT (33, 38, 41).

The measured value is called VOUT (33, 38, 41), and is treated as HBLK1.

VthRET Retrace BLK Input Threshold Voltage

Confirm that output signal is being blanked by the SG7 at the time.

Monitoring to output signal, decreasing the level of SG7. Measure the top level of SG7 when the blanking period is disappeared. The measured value is called VthRET.

SS-NV SOG Input Maximum Noise Voltage

The sync's amplitude of SG4 be changed all white into all black, increase from 0 V_{P-P} to 0.02 V_{P-P}. No pulse output permitted.

SS-SV SOG Minimum Input Voltage

The sync's amplitude of SG4 be changed all white or all black, decrease from 0.3 V_{P-P} to 0.2 V_{P-P}. Confirm no malfunction produced by noise.

VSH Sync Output High level

Measure the high voltage at SyncOUT. The measured value is treated as VSH.

VSL Sync Output Low Level

Measure the low voltage at SyncOUT. The measured value is treated as VSL.

TDS-F Sync Output Delay Time1

SyncOUT becomes High with sync part of SG4.

Measure the time needed for the rear edge of SG4 sync to fall from 50% and for SyncOUT to rise from 50% with an active probe. The measured value is treated as TDS-F, less than 90 ns.

TDS-R Sync Output Delay Time2

Measure the time needed for the rear edge of SG4 sync to rise from 50% and for SyncOUT to fall from 50% with an active probe. The measured value is treated as TDS-R, less than 90 ns.

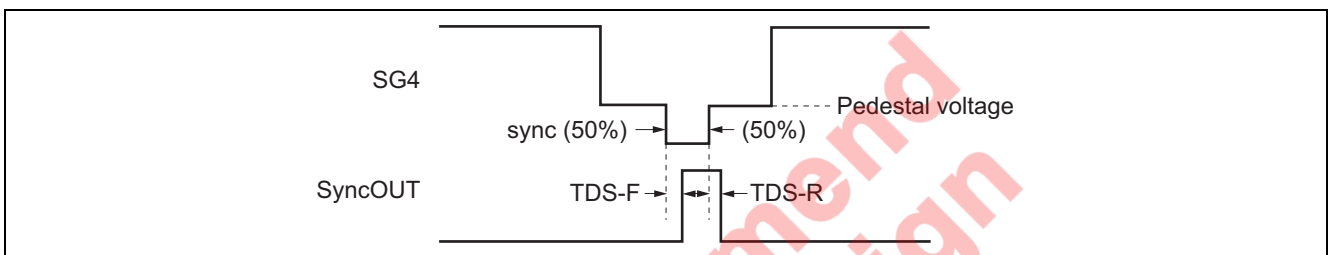
**VOH D/A H Output Voltage**

Measure the DC voltage at D/A OUT. The measured value is treated as VOH.

VOL D/A L Output Voltage

Measure the DC voltage at D/A OUT. The measured value is treated as VOL.

IA- D/A OUT Input Current

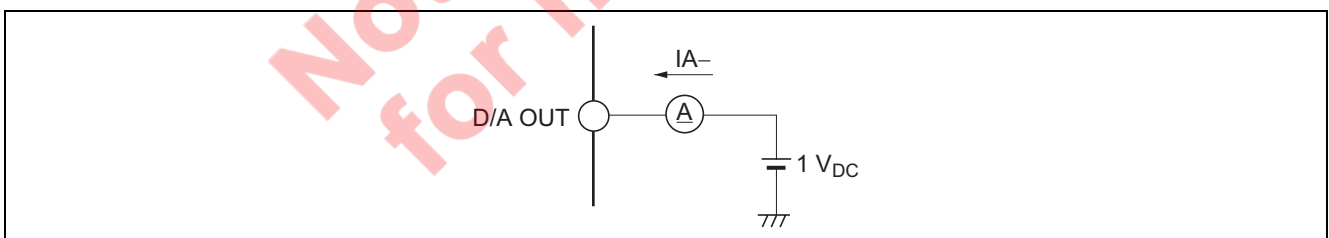

IA- is minimum input-current when input 1 V_{DC} to D/A OUT

**IA+ D/A OUT Output Current**

IA+ is maximum output-current from D/A OUT

DNL D/A Nonlinearity

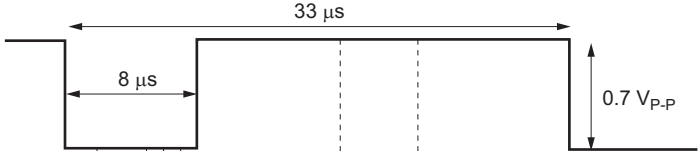
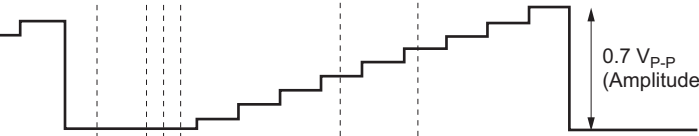
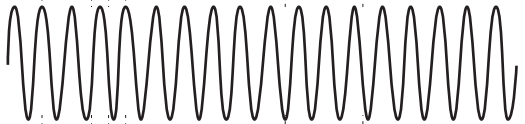
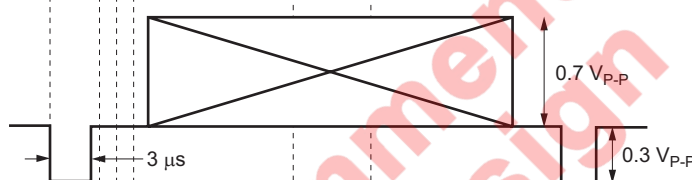
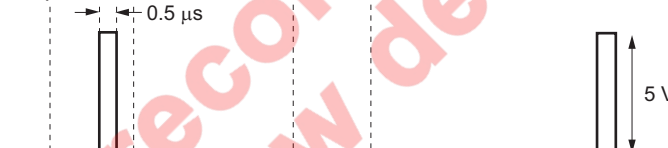
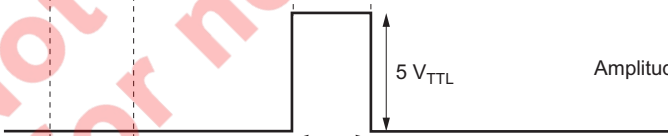
The difference of differential non-linearity of D/A OUT must be less than ± 1.0 LSB.

SG No.	Signals	
SG1 Video signal (all white)	Pulse with amplitude of $0.7 V_{P-P}$ ($f = 30 \text{ kHz}$). Video width of $25 \mu\text{s}$. (75%) 	
SG2 Video signal (step wave)		
SG3 Sine wave (for freq. char.)		
SG4 Video signal (all white, all black)	Video width of $25 \mu\text{s}$. (75%) 	all white or all black variable. Sync's amplitude is variable.
SG5 Clamp pulse	Pulse width and amplitude are variable. 	
SG6 OSD pulse		
SG7 BLK pulse		

Note: $f = 30 \text{ kHz}$

Test Circuit

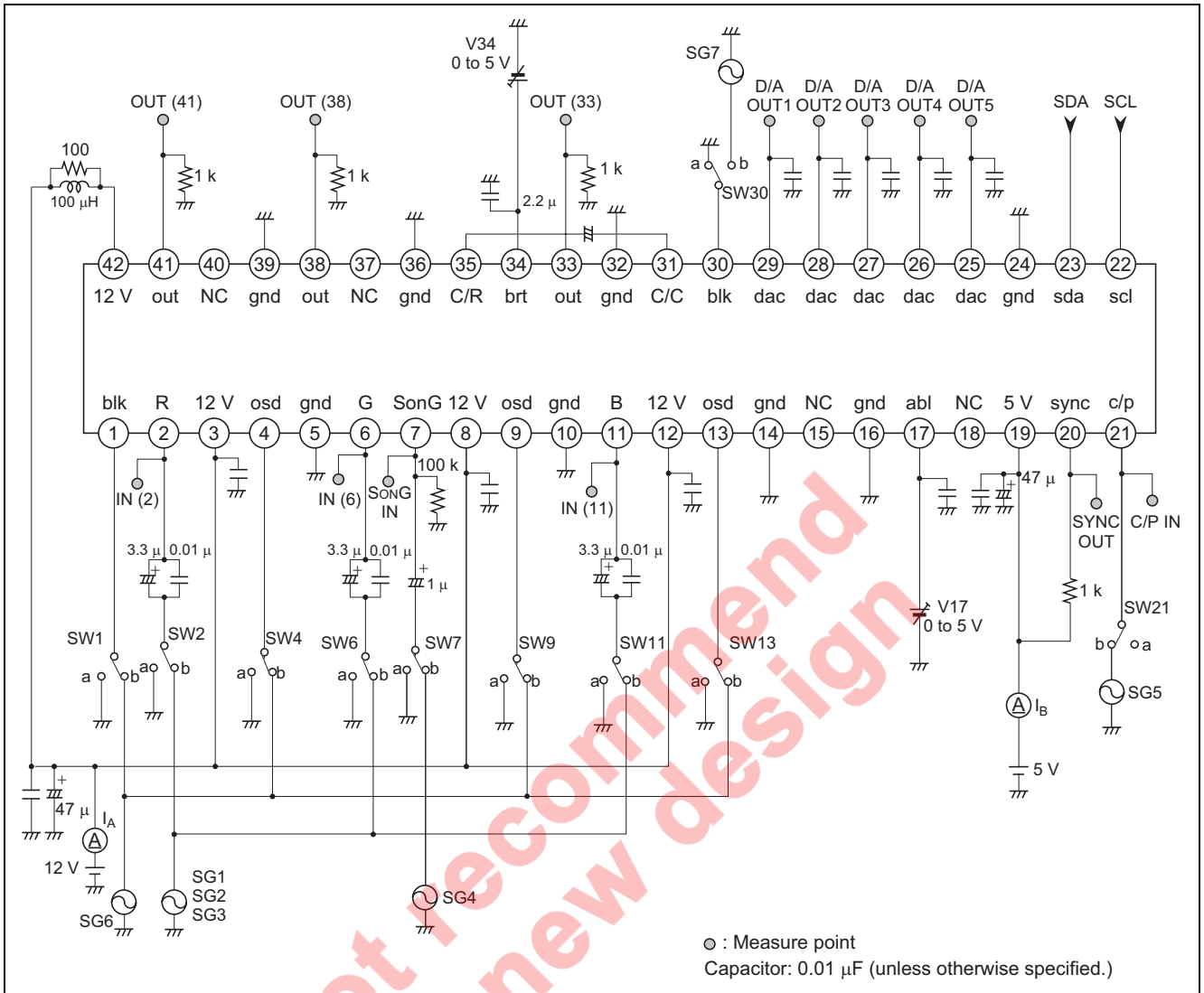

Pin Description

Pin No.	Name	DC Voltage (V)	Peripheral Circuit	Function
1	OSD BLK IN	—		<p>Input pulses</p> <p>Connected to GND if not used.</p>
2 6 11	INPUT (R) INPUT (G) INPUT (B)	2.5		<p>Clamped to about 2.5 V due to clamp pulses from pin 21. Input at low impedance.</p>
3 8 12	V _{CC1} (R) V _{CC1} (G) V _{CC1} (B)	12	—	<p>Apply equivalent voltage to 3 channels.</p>
4 9 13	OSD IN (R) OSD IN (G) OSD IN (B)	—		<p>Input pulses</p> <p>Connected to GND if not used.</p>
5 10 14 16 24 32 36 39	GND1 (R) GND1 (G) GND GND1 (B) GND (5 V) GND GND GND 2	GND	—	—

Pin Description (cont.)

Pin No.	Name	DC Voltage (V)	Peripheral Circuit	Function
7	INPUT (S on G)	When open 2.5 V		<p>SYNC ON VIDEO input pin. Sync is negative. Input signal at pin 7, compare with the reference voltage of internal circuit in order to separate sync signal from Sync on Green signal.</p>
17	ABL IN	When open 2.5 V		<p>ABL (Automatic Beam Limiter) input pin. Recommended voltage range is 0 to 5 V. When ABL function is not used, set to 5 V.</p>
15 18 37 40	NC	—	—	—
19	V _{CC} (5 V)	5	—	—
20	SonG Sep OUT	—		<p>Sync signal output pin, being of open collector output type.</p>

Not recommended for new design

Pin Description (cont.)

Pin No.	Name	DC Voltage (V)	Peripheral Circuit	Function
21	Clamp Pulse IN	—		Input pulses Input at low impedance
22	SCL	—		SCL of I ² C BUS (Serial clock line) $V_{TH} = 2.3 V$
23	SDA	—		SDA of I ² C BUS (Serial data line) $V_{TH} = 2.3 V$
25 26 27 28 29	D/A OUT	—		D/A output pin. Output voltage range is 0 to 5 V. Min input current is 0.18 mA when D/A output pin is 1 V. Max output current is 1.0 mA.

Not recommended for new designs

Pin Description (cont.)

Pin No.	Name	DC Voltage (V)	Peripheral Circuit of Pin	Description of Function
30	Retrace BLK IN	—		Input pulses Connected to GND if not used.
31 35	Main Contrast Cont Main Contrast Ref	3.5 to 5.5 4.5		Non-polar capacitance is required between pin 31 and pin 35.
33 38 41	OUTPUT (B) OUTPUT (G) OUTPUT (R)	Variable		A resistor is needed on the GND side. Set discretionaly to maximum 15 mA, depending on the required driving capacity.
42	V _{CC2}	12		Used to supply power to output emitter follower only.
34	Main Brightness	—		It is recommended that the IC be used between pedestal voltage 2 V and 3 V.

Typical Characteristics

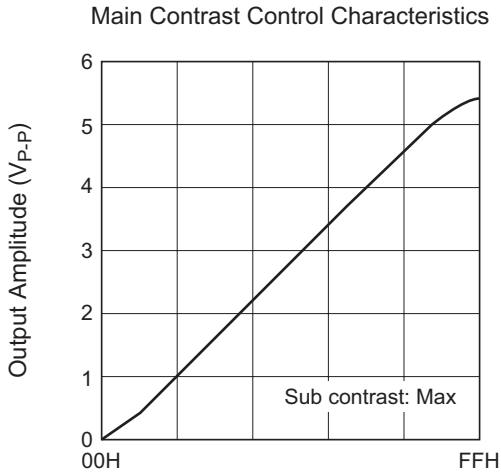

Main Contrast Control Data

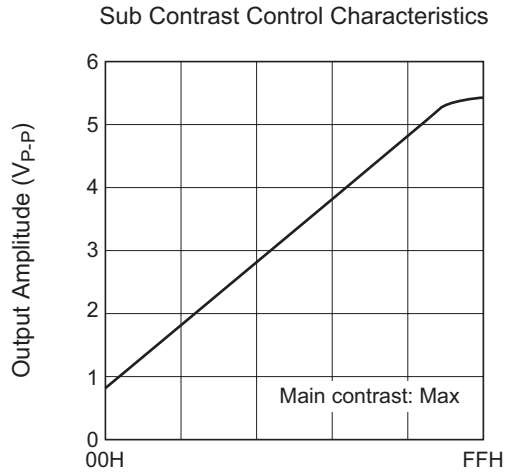

Sub Contrast Control Data

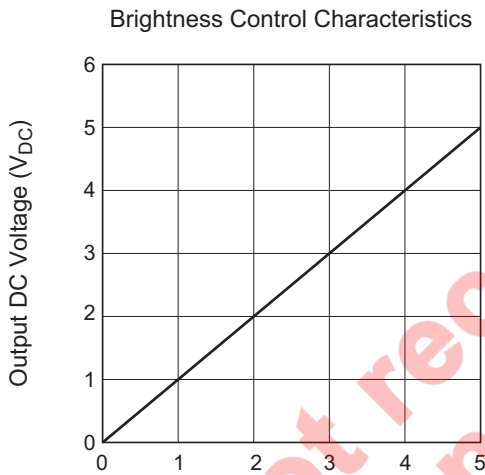

Brightness Control Voltage (V_{DC})

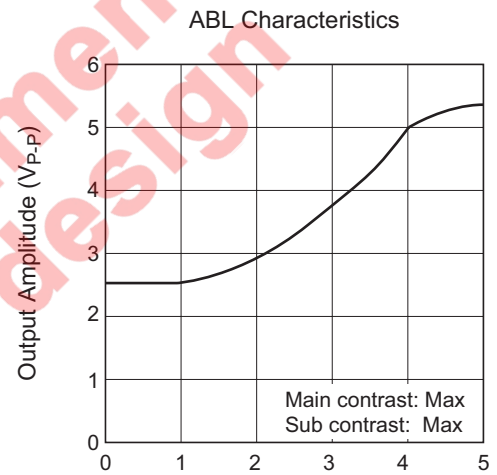

ABL Control Voltage (V_{DC})

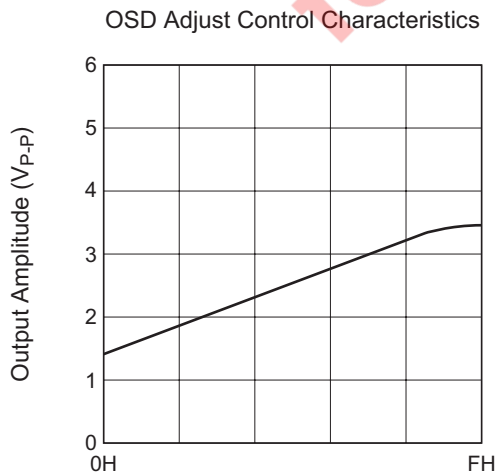

OSD Adjust Control Data

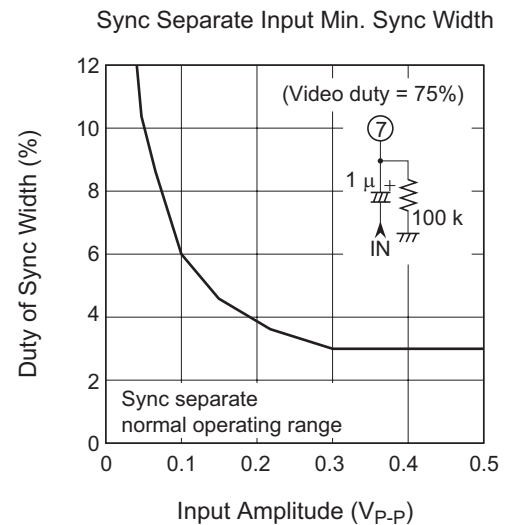

Application Method for M52749FP

Clamp Pulse Input

Clamp pulse width is recommended

above 15 kHz, 1.0 μ s

above 30 kHz, 0.5 μ s

above 64 kHz, 0.3 μ s

The clamp pulse circuit in ordinary set is a long round about way, and beside high voltage, sometimes connected to external terminal, it is very easy affected by large surge.

Therefore, the figure shown below is recommended.

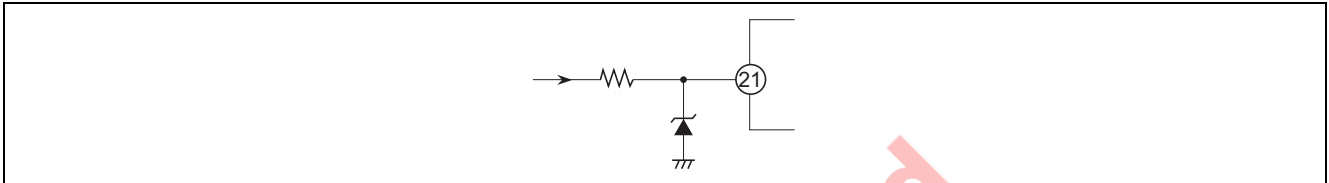

Notice of Application

Make the nearest distance between output pin and pull down resistor.

Recommended pedestal voltage of IC output signal is 2 V.

Not recommend
for new design

Package Dimensions

JEITA Package Code	RENESAS Code	Previous Code	MASS[Typ.]
P-HSSOP42-8.4x17.5-0.80	PRSP0042GB-A	42P9R-A	0.7g

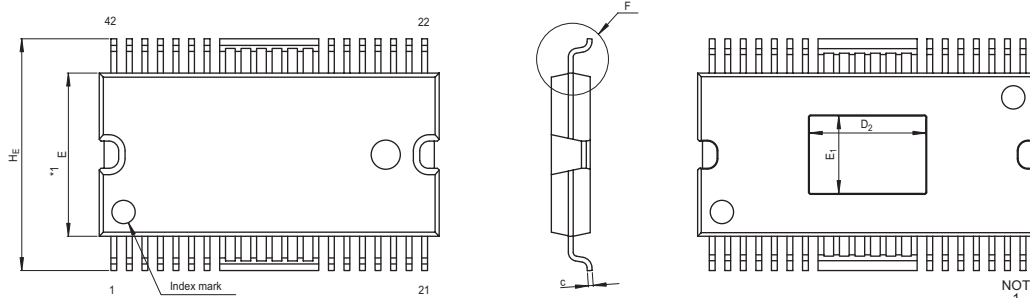

NOTE)
 1. DIMENSIONS **1* AND **2* DO NOT INCLUDE MOLD FLASH.
 2. DIMENSION **3* DOES NOT INCLUDE TRIM OFFSET.

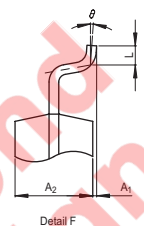
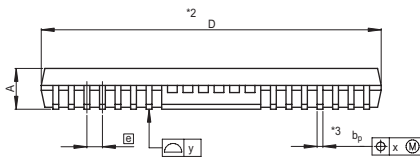

Reference Symbol	Dimension in Millimeters		
	Min	Nom	Max
D	17.3	17.5	17.7
E	8.2	8.4	8.6
A ₂	—	2.0	—
A	—	—	2.2
A ₁	0	0.1	0.2
b _p	0.27	0.32	0.37
c	0.23	0.25	0.3
θ	0°	—	10°
H _E	11.63	11.93	12.23
Ⓜ	—	0.8	—
x	—	—	0.12
y	—	—	0.10
L	0.3	0.5	0.7
D ₂	5.8	6.0	6.2
E ₁	3.8	4.0	4.2

Not recommended for new design

Notes:

1. This document is provided for reference purposes only so that Renesas customers may select the appropriate Renesas products for their use. Renesas neither makes warranties or representations with respect to the accuracy or completeness of the information contained in this document nor grants any license to any intellectual property rights or any other rights of Renesas or any third party with respect to the information in this document.
2. Renesas shall have no liability for damages or infringement of any intellectual property or other rights arising out of the use of any information in this document, including, but not limited to, product data, diagrams, charts, programs, algorithms, and application circuit examples.
3. You should not use the products or the technology described in this document for the purpose of military applications such as the development of weapons of mass destruction or for the purpose of any other military use. When exporting the products or technology described herein, you should follow the applicable export control laws and regulations, and procedures required by such laws and regulations.
4. All information included in this document such as product data, diagrams, charts, programs, algorithms, and application circuit examples, is current as of the date this document is issued. Such information, however, is subject to change without any prior notice. Before purchasing or using any Renesas products listed in this document, please confirm the latest product information with a Renesas sales office. Also, please pay regular and careful attention to additional and different information to be disclosed by Renesas such as that disclosed through our website. (<http://www.renesas.com>)
5. Renesas has used reasonable care in compiling the information included in this document, but Renesas assumes no liability whatsoever for any damages incurred as a result of errors or omissions in the information included in this document.
6. When using or otherwise relying on the information in this document, you should evaluate the information in light of the total system before deciding about the applicability of such information to the intended application. Renesas makes no representations, warranties or guarantees regarding the suitability of its products for any particular application and specifically disclaims any liability arising out of the application and use of the information in this document or Renesas products.
7. With the exception of products specified by Renesas as suitable for automobile applications, Renesas products are not designed, manufactured or tested for applications or otherwise in systems the failure or malfunction of which may cause a direct threat to human life or create a risk of human injury or which require especially high quality and reliability such as safety systems, or equipment or systems for transportation and traffic, healthcare, combustion control, aerospace and aeronautics, nuclear power, or undersea communication transmission. If you are considering the use of our products for such purposes, please contact a Renesas sales office beforehand. Renesas shall have no liability for damages arising out of the uses set forth above.
8. Notwithstanding the preceding paragraph, you should not use Renesas products for the purposes listed below:
 - (1) artificial life support devices or systems
 - (2) surgical implantations
 - (3) healthcare intervention (e.g., excision, administration of medication, etc.)
 - (4) any other purposes that pose a direct threat to human lifeRenesas shall have no liability for damages arising out of the uses set forth in the above and purchasers who elect to use Renesas products in any of the foregoing applications shall indemnify and hold harmless Renesas Technology Corp., its affiliated companies and their officers, directors, and employees against any and all damages arising out of such applications.
9. You should use the products described herein within the range specified by Renesas, especially with respect to the maximum rating, operating supply voltage range, movement power voltage range, heat radiation characteristics, installation and other product characteristics. Renesas shall have no liability for malfunctions or damages arising out of the use of Renesas products beyond such specified ranges.
10. Although Renesas endeavors to improve the quality and reliability of its products, IC products have specific characteristics such as the occurrence of failure at a certain rate and malfunctions under certain use conditions. Please be sure to implement safety measures to guard against the possibility of physical injury, and injury or damage caused by fire in the event of the failure of a Renesas product, such as safety design for hardware and software including but not limited to redundancy, fire control and malfunction prevention, appropriate treatment for aging degradation or any other applicable measures. Among others, since the evaluation of microcomputer software alone is very difficult, please evaluate the safety of the final products or system manufactured by you.
11. In case Renesas products listed in this document are detached from the products to which the Renesas products are attached or affixed, the risk of accident such as swallowing by infants and small children is very high. You should implement safety measures so that Renesas products may not be easily detached from your products. Renesas shall have no liability for damages arising out of such detachment.
12. This document may not be reproduced or duplicated, in any form, in whole or in part, without prior written approval from Renesas.
13. Please contact a Renesas sales office if you have any questions regarding the information contained in this document, Renesas semiconductor products, or if you have any other inquiries.



RENESAS SALES OFFICES

<http://www.renesas.com>

Refer to "<http://www.renesas.com/en/network>" for the latest and detailed information.

Renesas Technology America, Inc.
450 Holger Way, San Jose, CA 95134-1368, U.S.A
Tel: <1> (408) 382-7500, Fax: <1> (408) 382-7501

Renesas Technology Europe Limited
Dukes Meadow, Millboard Road, Bourne End, Buckinghamshire, SL8 5FH, U.K.
Tel: <44> (1628) 585-100, Fax: <44> (1628) 585-900

Renesas Technology (Shanghai) Co., Ltd.
Unit 204, 205, AZIA Center, No.1233 Lujiazui Ring Rd, Pudong District, Shanghai, China 200120
Tel: <86> (21) 5877-1818, Fax: <86> (21) 6887-7858/7898

Renesas Technology Hong Kong Ltd.
7th Floor, North Tower, World Finance Centre, Harbour City, Canton Road, Tsimshatsui, Kowloon, Hong Kong
Tel: <852> 2265-6688, Fax: <852> 2377-3473

Renesas Technology Taiwan Co., Ltd.
10th Floor, No.99, Fushing North Road, Taipei, Taiwan
Tel: <886> (2) 2715-2888, Fax: <886> (2) 3518-3399

Renesas Technology Singapore Pte. Ltd.
1 Harbour Front Avenue, #06-10, Keppel Bay Tower, Singapore 098632
Tel: <65> 6213-0200, Fax: <65> 6278-8001

Renesas Technology Korea Co., Ltd.
Kukje Center Bldg. 18th Fl., 191, 2-ka, Hangang-ro, Yongsan-ku, Seoul 140-702, Korea
Tel: <82> (2) 796-3115, Fax: <82> (2) 796-2145

Renesas Technology Malaysia Sdn. Bhd
Unit 906, Block B, Menara Amcorp, Amcorp Trade Centre, No.18, Jln Persiaran Barat, 46050 Petaling Jaya, Selangor Darul Ehsan, Malaysia
Tel: <603> 7955-9390, Fax: <603> 7955-9510