

To all our customers

---

## **Regarding the change of names mentioned in the document, such as Mitsubishi Electric and Mitsubishi XX, to Renesas Technology Corp.**

---

The semiconductor operations of Hitachi and Mitsubishi Electric were transferred to Renesas Technology Corporation on April 1st 2003. These operations include microcomputer, logic, analog and discrete devices, and memory chips other than DRAMs (flash memory, SRAMs etc.) Accordingly, although Mitsubishi Electric, Mitsubishi Electric Corporation, Mitsubishi Semiconductors, and other Mitsubishi brand names are mentioned in the document, these names have in fact all been changed to Renesas Technology Corp. Thank you for your understanding. Except for our corporate trademark, logo and corporate statement, no changes whatsoever have been made to the contents of the document, and these changes do not constitute any alteration to the contents of the document itself.

Note : Mitsubishi Electric will continue the business operations of high frequency & optical devices and power devices.

Renesas Technology Corp.  
Customer Support Dept.  
April 1, 2003

## Description

The M16C/6K7 (144-pin version) group of single-chip microcomputers are built using the high-performance silicon gate CMOS process using a M16C/60 Series CPU core and are packaged in a 144-pin plastic molded QFP. These single-chip microcomputers operate using sophisticated instructions featuring a high level of instruction efficiency. To communicate with host CPU, the LPC bus interface is built in. In this way, this MCU can work as slave controller in the personal computer system.

The specification is target oriented specification for the development of M16C/6K7 (144-pin version).

## Features

- Memory capacity ..... ROM (Refer to the figure of ROM Expansion)  
RAM 3K bytes
- The Min. time of instruction execution ... 125.0ns (f(XIN)=8MHz, with 0 wait, Vcc=3V)
- Supply voltage ..... 3.0 to 3.6V (f(XIN)=8MHz with 0 wait)
- Low power consumption ..... Target 41.3mW ( f(XIN)=8MHz, with 0 wait, Vcc = 3.3V)
- Interrupts ..... 36 internal and 15 external interrupt sources, 4 software interrupt sources; 7 levels (including key input interrupt)
- Multifunction 16-bit timer ..... 5 output timers + 6 input timers
- Serial I/O ..... 5 channels (3 for UART or clock synchronous, 2 for clock synchronous)
- DMAC ..... 2 channels
- Host interface ..... LPC bus interface X 4
- A-D converter ..... 10 bits X 8 channels (Expandable up to 10 channels)
- D-A converter ..... 8 bits X 2 channels
- Comparator circuit ..... 8 channels
- PWM ..... 14 bits X 4 channels
- Watchdog timer ..... 1
- I<sup>2</sup>C bus interface ..... 2 channels
- Serial interrupt output ..... 6 factors (2 fixed factors, 4 programmable factors)
- PS/2 interface ..... 3 channels
- Programmable I/O ..... 129
- Input port ..... 1 (P85 shared with  $\overline{\text{NMI}}$  pin)
- Clock generating circuit ..... 2 built-in clock generation circuits  
(built-in feedback resistor, and external ceramic or quartz oscillator)

## Applications

Notebook PC, others

Specifications written in this manual are believed to be accurate, but are not guaranteed to be entirely free of error. Specifications in this data sheet may be changed for functional or performance improvements. Please make sure your manual is the latest edition.

## -----Table of Contents-----

Central Processing Unit (CPU) .....	13
Reset .....	16
Processor Mode .....	26
Clock Generating Circuit .....	29
Protection .....	38
Interrupts .....	39
Watchdog Timer .....	63
DMAC .....	65
Timer .....	74
Serial I/O .....	92
A-D Converter .....	126
D-A Converter .....	136
Comparator Circuit .....	138
PWM Output Circuit .....	140
LPC Bus Interface .....	145
I <sup>2</sup> C-BUS Interface .....	172
PS2 Interface .....	203
Programmable I/O Ports .....	218
Electrical Characteristics .....	237
Flash Memory Version .....	250

**The differences in M16C/6K (144-pin) group**

Type name	M306K5F8LRP	M306K7F8LRP
Pin numbers	144-pin	144-pin
ROM	NEW DINOR Flash memory	NEW DINOR Flash memory
Built-in ROM area	User ROM area Address 0E8000 <sub>16</sub> - 0F5FFF <sub>16</sub> Address 0FE000 <sub>16</sub> - 0FFFFFF <sub>16</sub> Boot ROM area In parallel I/O mode Address 0FE000 <sub>16</sub> - 0FFFFFF <sub>16</sub> In CPU reprogram mode & standard serial I/O mode Address 0DE000 <sub>16</sub> - 0DFFFF <sub>16</sub>	User ROM area Address 0EF000 <sub>16</sub> - 0FFFFFF <sub>16</sub> Boot ROM area Address 0FF000 <sub>16</sub> - 0FFFFFF <sub>16</sub>
Address 03B4 <sub>16</sub>	Flash memory control register After reset XXXX0001 <sub>2</sub>	Flash memory recognition register After reset 00000000 <sub>2</sub>
Address 03B7 <sub>16</sub> After reset 00000000 <sub>2</sub>	Flash memory recognition register After reset 00000000 <sub>2</sub>	Flash memory control register After reset XX000001 <sub>2</sub>
The power supply for program/erase	Vcc 3.0 - 3.6V M2 pin 4.5 - 5.25V	Vcc 3.0 - 3.6V
M2 pin	The input pin of power supply for program/erase	Not exist
Programmable I/O	128 Port 0 - Port 16 without P84	129 Port 0 - Port 16
The I/O voltage in P2, P3 Programmable I/O ports	3.3V/5V	3.3V
ISA bus interface	Exist	Not exist
Serial interrupt output & LPC bus interface	Exist	Exist
Timer B TB2IN	Not exist	Exist

Note 1: Timer B TB2IN refers to the count source input and pulse period measurement in event count mode/ pulse input in pulse width measurement mode.

### Pin Configuration

Fig.AA-1 shows the pin configurations (top view).

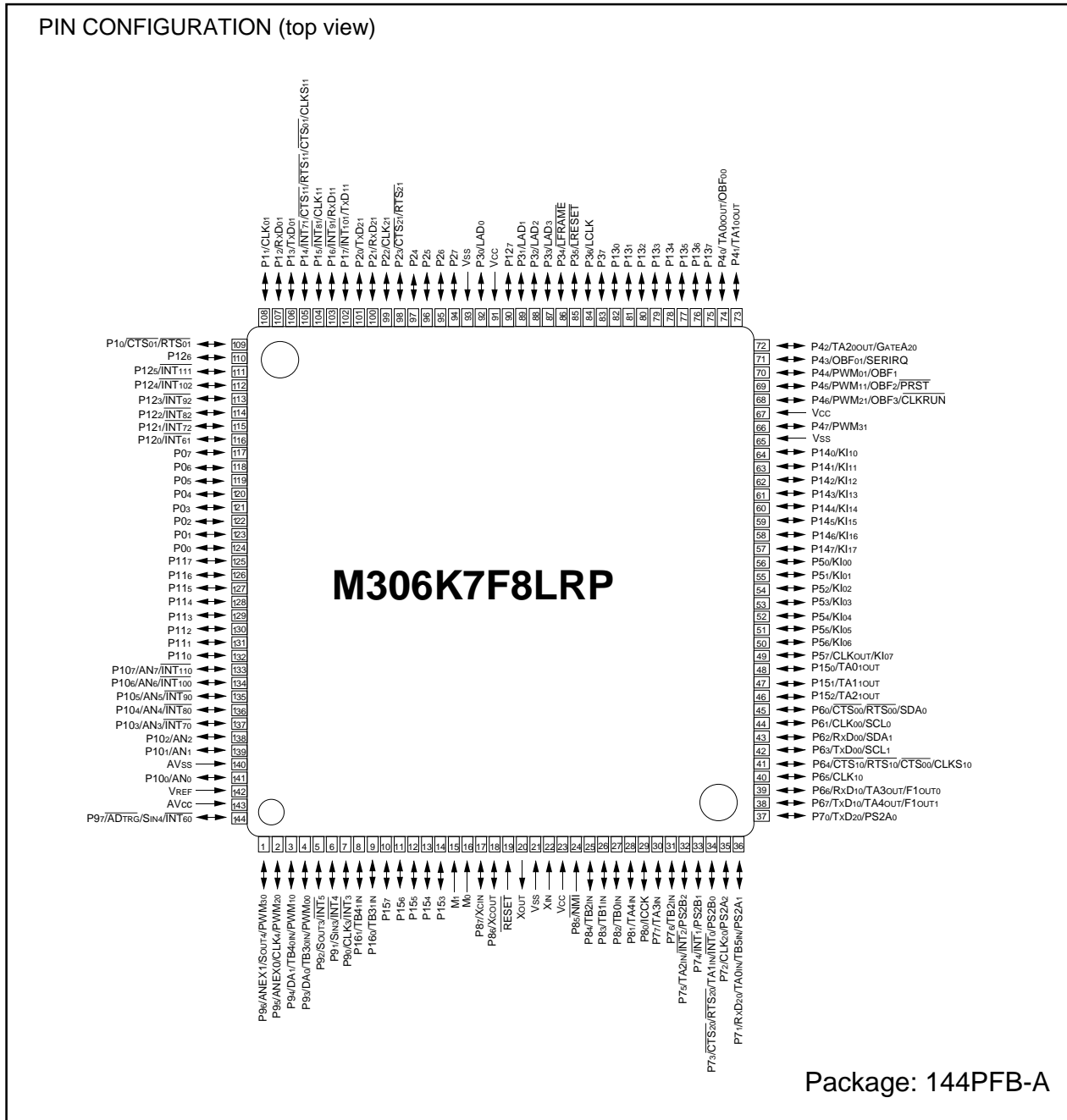
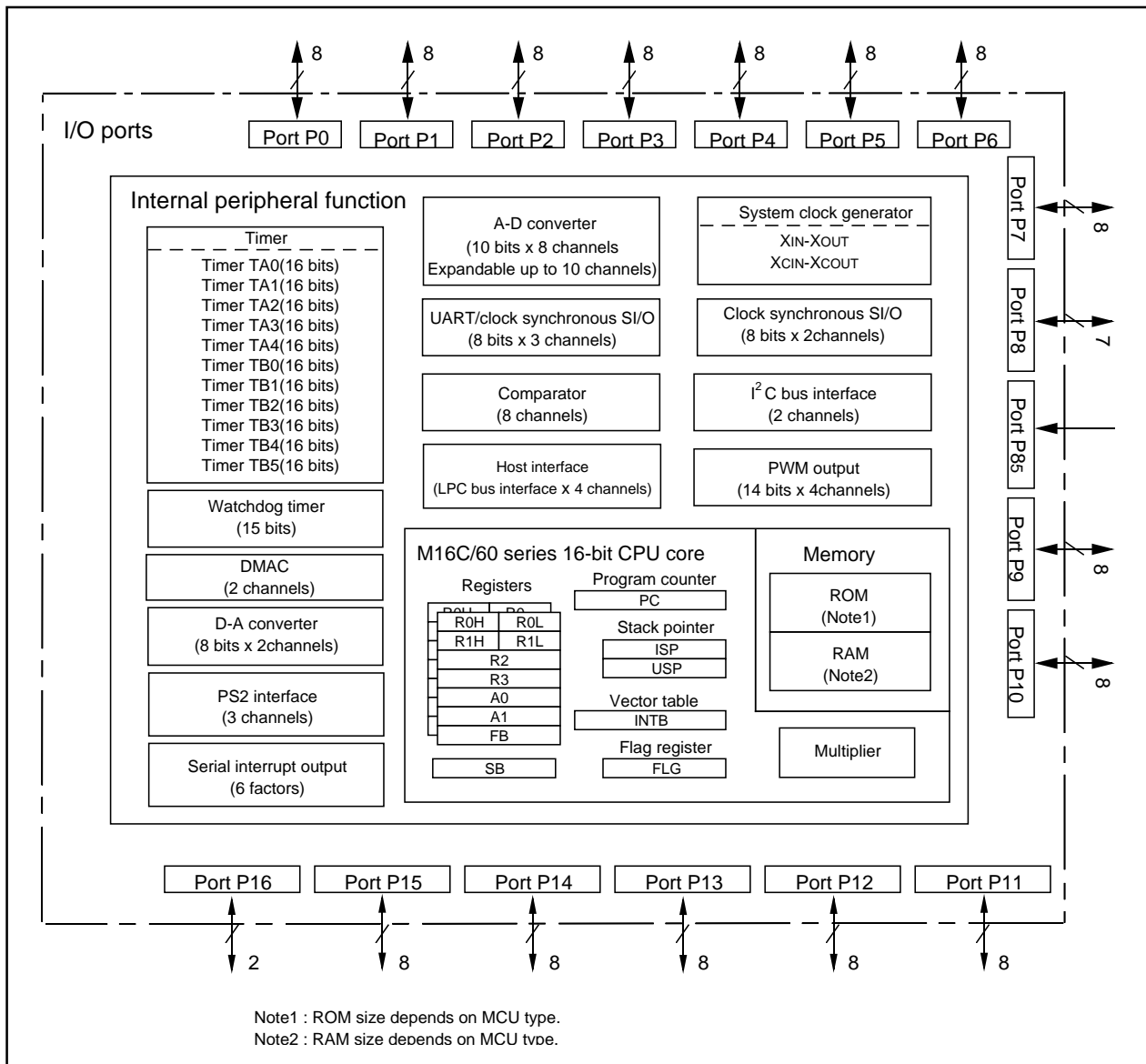

Fig. AA-1 Pin configuration (top view)

**Block Diagram**

Fig.AA-2 is a block diagram of the M16C/6K7 (144-pin version) group.



**Fig.AA-2 Block diagram of M16C/6K7 (144-pin version) group**

## Description

**Performance Outline**

Table AA-1 is a performance outline of M16C/6K7 (144-pin version) group.

**Table AA-1 Performance outline of M16C/6K7 (144-pin version) group**

Item	Performance	
Number of basic instructions	91 instructions	
The Min. time of instruction execution	125ns (f(XIN)=8MHz, with 0 wait, Vcc=3V)	
Memory capacity	ROM	(See the figure of ROM Expansion)
	RAM	3K bytes
I/O port	P0 to P10 (except P85)	8 bits x 10, 7 bits x 1
	P11 to P16	8 bitsx5, 2 bitsx1
Input port	P85	1 bit x 1
Multifunction timer	TA0, TA1, TA2, TA3, TA4	16 bits x 5
	TB0, TB1, TB2, TB3, TB4, TB5	16 bits x 6
Serial I/O	UART0, UART1, UART2	(UART or clock synchronous) x 3
	SI/O3, SI/O4	(Clock synchronous) x 2
A-D converter	10 bits x (8 + 2) channels	
D-A converter	8 bits x 2	
DMAC	2 channels (trigger: 24 sources)	
Watchdog timer	15 bits x 1 (with prescaler)	
Interrupt	36 internal and 15 external sources, 4 software sources, 7 levels	
Host interface	4 channels (LPC bus interface)	
Comparator circuit	8 channels	
PWM	14 bits x 4	
I <sup>2</sup> C bus interface	2 channels	
PS2 interface	3 channels	
Serial interrupt output	6 factors (2 fixed factors, 4 programmable factors)	
Clock generating circuit	2 built-in clock generation circuits (built-in feedback resistor, and external ceramic or quartz oscillator)	
Supply voltage	3.0 to 3.6V (f(XIN)=8MHz with 0 wait)	
Power consumption	41.3mW (3.3V, f(XIN)=8MHz, with 0 wait)	
I/O characteristics	I/O withstand voltage	3.3V
	Output current	5mA
Device configuration	CMOS high performance silicon gate	
Package	144-pin plastic mold QFP	

Description

Mitsubishi plans to release the following products in the M16C/6K7 (144-pin version) group:

- (1) Support for flash memory version
- (2) ROM capacity
- (3) Package
  - 144PFB-A : Plastic molded QFP(flash memory version)

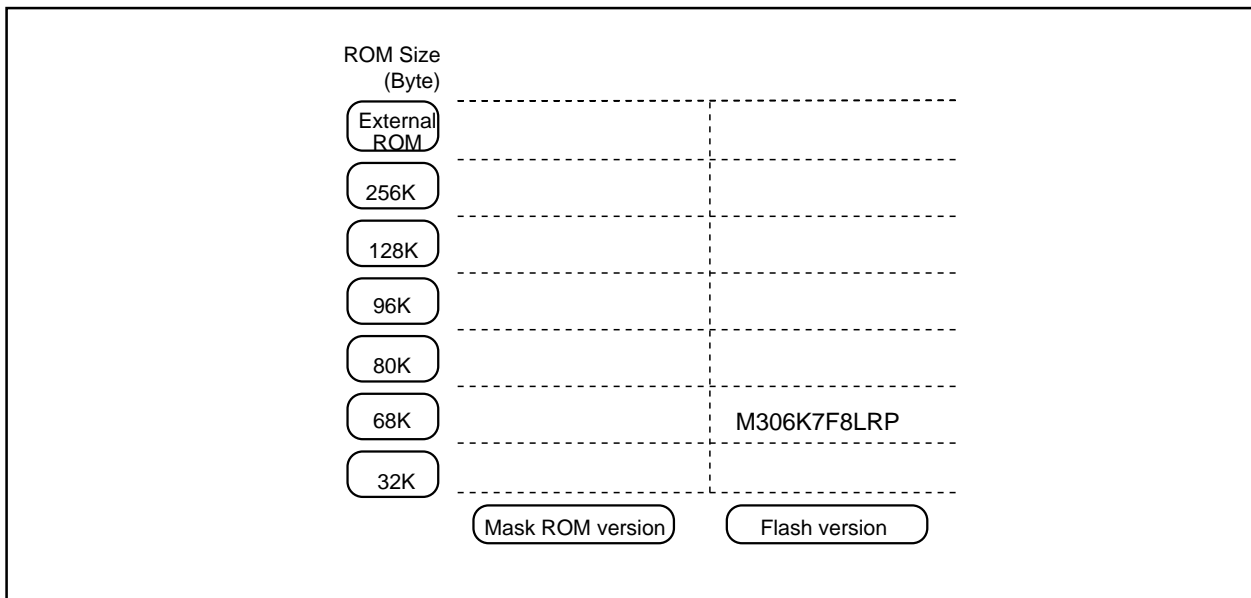

**Fig.AA-3 ROM expansion**

**Table AA-2 Product list**

Type No.	ROM size	RAM size	Package type	Host Interface	Remarks
M306K7F8LRP	68K bytes	3K bytes	144PFB-A	LPC	Flash memory (NEW DINOR) version



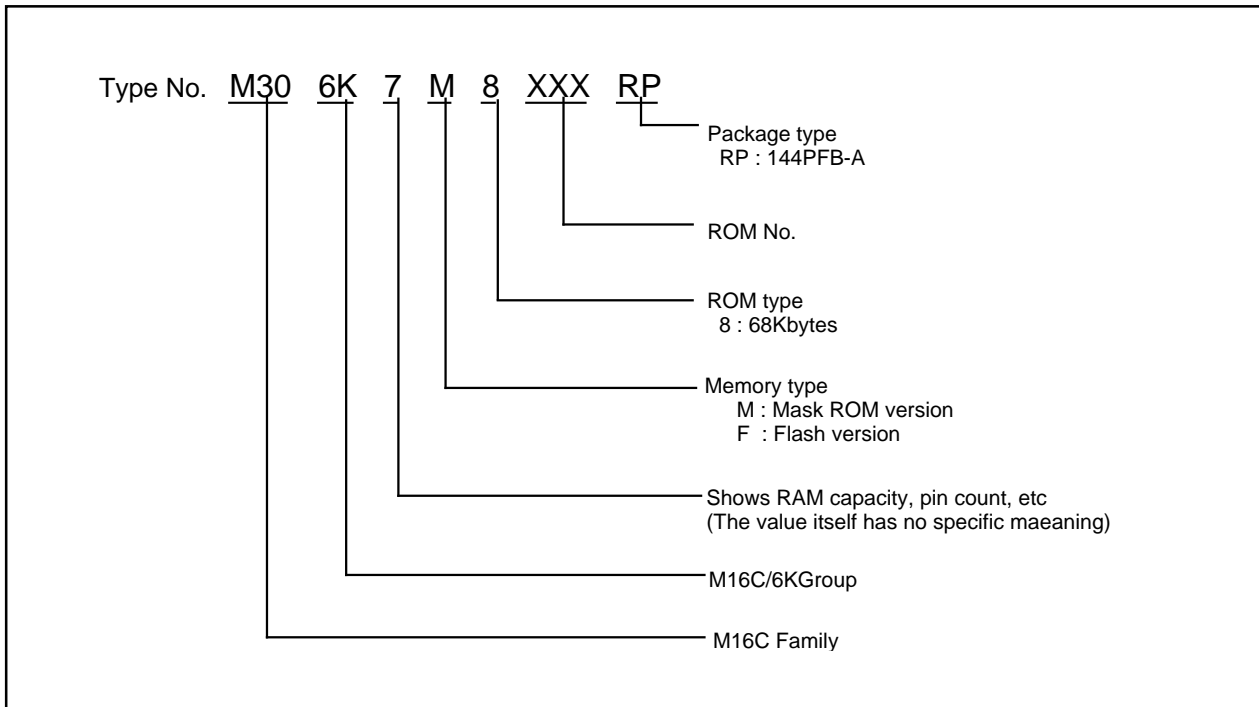

Fig.AA-4 Type No., memory size, and package

## Pin Description

## Pin Description

Pin name	Signal name	I/O type	Function
Vcc, Vss	Power supply input		Apply 3.0 to 3.6 V to Vcc . Apply 0V to Vss
RESET	Reset input	Input	A "L" on this input resets the microcomputer.
XIN XOUT	Clock input Clock output	Input Output	These pins are provided for the main clock generating circuit. Connect a ceramic resonator or crystal between the XIN and the XOUT pins. To use an externally derived clock, input it to the XIN pin and leave the XOUT pin open.
M0,M1	Chip mode setting	Input	Connect to Vss
AVCC	Analog power supply input		This pin is a power supply input for the A-D converter. Connect this pin to VCC.
AVSS	Analog power supply input		This pin is a power supply input for the A-D converter. Connect this pin to Vss.
VREF	Reference voltage input	Input	This pin is a reference voltage input for the A-D converter.
P00 to P07	I/O port P0	Input/output	This is an 8-bit CMOS I/O port. It has an input/output port direction register that allows the user to set each pin for input or output individually. When set for input, the user can specify in units of four bits via software whether or not they are tied to a pull-up resistor. This port supports CMOS input level. And output type supports CMOS 3 state or N channel open drain selectable.
P10 to P17	I/O port P1	Input/output	This is an 8-bit I/O port equivalent to P0. Pins in this port also function as external interrupt pins as selected by software.
P20 to P27	I/O port P2	Input/output	This is an 8-bit I/O port equivalent to P0. (Except that output type just supports CMOS 3 state only). The 4 bits P24-P27 are available for directly driving LED's.
P30 to P37	I/O port P3	Input/output	This is an 8-bit I/O port equivalent to P0. (Except that output type just supports CMOS 3 state only). The port can be used for LPC bus interface I/O pins by software selection.
P40 to P47	I/O port P4	Input/output	This is an 8-bit I/O port equivalent to P0. (Except that output type just supports CMOS 3 state only). By software selecting, the port can also be used for LPC bus interface I/O pins, Timer A0 to A2 output pins PWM output pins or serial interrupt output I/O pins. P40 to P46 pins' level can be read regardless the setting of input port or output port. If P40 or P43 are used for output ports, the function that clears P40 or P43 to "0" after the read of output data buffer from host CPU is available.
P50 to P57	I/O port P5	Input/output	This is an 8-bit I/O port equivalent to P0. (Except that output type is CMOS 3 state only). Key on wake interrupt 0 and comparator input function support. P57 in this port outputs a divide-by-8 or divide-by-32 clock of XIN or a clock of the same frequency as XCIN as selected by software.

**Pin Description**

Pin name	Signal name	I/O type	Function
P60 to P67	I/O port P6	Input/output	This is an 8-bit I/O port equivalent to P0. (Except that P60 to P63's output type is N channel open drain only; P64 to P67's output type is CMOS 3 state only; P60 to P63 no internal pull-up resistor support.) By software selecting, this port can be used for I <sup>2</sup> C-BUS interface, UART0/UART1 input/output pin, timerA3,A4 output pin or same frequency with XIN clock output pin. When P60 to P63 used as I <sup>2</sup> C-BUS interface SDA,SCL, the input level of these pins are CMOS/SMBUS selectable.
P70 to P77	I/O port P7	Input/output	This is an 8-bit I/O port equivalent to P0. (Except that P70 to P77 output type is N channel open drain only; no internal pull-up resistor support.) By software selecting, this port can be used for external interrupt input pin, timerA0 to A3 and timerB5 input pin, PS2 interface input/output pin, or UART2 input/output pin. P70 to P75 pins' level can be read regardless of the setting of input port or output port.
P80 to P84, P86, P87, P85	I/O port P8  I/O port P85	Input/output Input/output Input/output Input	P80 to P84, P86, and P87 are I/O ports with the same functions as P0. (Except that P86 to P87's output type is CMOS 3 state only; P80 to P84's output type is N channel open drain only; P85 is input port only; the P80 to P84 and P85 are no internal pull-up resistor support.) By software selecting, this port can be used for timer A4, B0 to B2, I <sup>2</sup> C-BUS interface I/O pins. P86 and P87 can be set using software to function as the I/O pins for a sub clock generation circuit. In this case, connect a quartz oscillator between P86 (XcOUT pin) and P87 (XcIN pin). P85 is an input-only port that also functions for $\overline{\text{NMI}}$ . The $\overline{\text{NMI}}$ interrupt is generated when the input at this pin changes from "H" to "L". The $\overline{\text{NMI}}$ function cannot be cancelled using software.
P90 to P97	I/O port P9	Input/output	This is an 8-bit I/O port equivalent to P0. (Except that output type is CMOS 3 state only.) By software selecting, the port can be used for external interrupt, timer B3 to B4, A-D converter extended input pins, A-D trigger, SI/O3, SI/O4 I/O pins, PWM, D-A converter output pins.
P100 to P107	I/O port P10	Input/output	This is an 8-bit I/O port equivalent to P0. (Except that output type is CMOS 3 state only.) By software selecting, the port can be used for A-D converter, external interrupt input pins.

## Pin Description

## Pin Description

Pin name	Signal name	I/O type	Function
P110 to P117	I/O port P11	Input/output	This is an 8-bit I/O port equivalent to P0.
P120 to P127	I/O port P12	Input/output	This is an 8-bit I/O port equivalent to P0. (Except that output type is CMOS 3 state only.) By software selecting, this port can be used for external interrupt input pin.
P130 to P137	I/O port P13	Input/output	This is an 8-bit I/O port equivalent to P0. (Except that output type is N channel open drain only; no internal pull-up resistor support.)
P140 to P147	I/O port P14	Input/output	This is an 8-bit I/O port equivalent to P0. The port can be used for key on wake-up interrupt 1 input pins. P140 to P143 are available for directly driving LED's.
P150 to P157	I/O port P15	Input/output	This is an 8-bit I/O port equivalent to P0. (Except that output type is CMOS 3 state only.) By software selecting, this port can be used for timer A0 to A2's output pin.
P160, P161	I/O port P16	Input/output	This is an 2-bit I/O port equivalent to P0. (Except that output type is CMOS 3 state only.) By software selecting, this port can be used for timer B3 and B4 input pin.

### Operation of Functional Blocks

The M16C/6K7 (144-pin version) group accommodates certain units in a single chip. These units include ROM and RAM to store instructions and data and the central processing unit (CPU) to execute arithmetic/logic operations. Also peripheral units such as timers, serial I/O, D-A converter, DMAC, A-D converter, host bus interface, comparator, PWM output, I<sup>2</sup>C BUS interface, PS2 interface and I/O ports are included.

The following explains each unit.

### Memory

Fig.CA-1 is the memory map. The address space extends up to 1M bytes from address 00000<sub>16</sub> to FFFFF<sub>16</sub>. From FFFFF<sub>16</sub> to the address decreasing direction ROM is allocated. For example, in the M306K7F8LRP, there is 68K bytes of internal ROM from EF000<sub>16</sub> to FFFFF<sub>16</sub>. The vector table for fixed interrupts such as the reset and NMI are mapped from FFFDC<sub>16</sub> to FFFFF<sub>16</sub>. The starting address of the interrupt routine is stored here. The address of the vector table for timer interrupts, etc., can be set as desired using the internal register (INTB). See the section on interrupts for details.

From 00400<sub>16</sub> to the address increasing direction RAM is allocated. For example, in the M306K7F8LRP, 3K bytes of internal RAM is mapped to the space from 00400<sub>16</sub> to 00FFF<sub>16</sub>. In addition to storing data, the RAM also stores the stack used when calling subroutines and when interrupts are generated.

The SFR area is mapped from 00000<sub>16</sub> to 003FF<sub>16</sub>. This area accommodates the control registers for peripheral devices such as I/O ports, A-D converter, serial I/O, and timers, etc. Fig.CA-2 to CA-5 are location of peripheral unit control registers. Any part of the SFR area that is not occupied is reserved and cannot be used for other purposes.

The special page vector table is mapped from FFE00<sub>16</sub> to FFFDB<sub>16</sub>. If the starting addresses of subroutines or the destination addresses of jumps are stored here, subroutine call instructions and jump instructions can be used as 2-byte instructions, reducing the number of program steps.

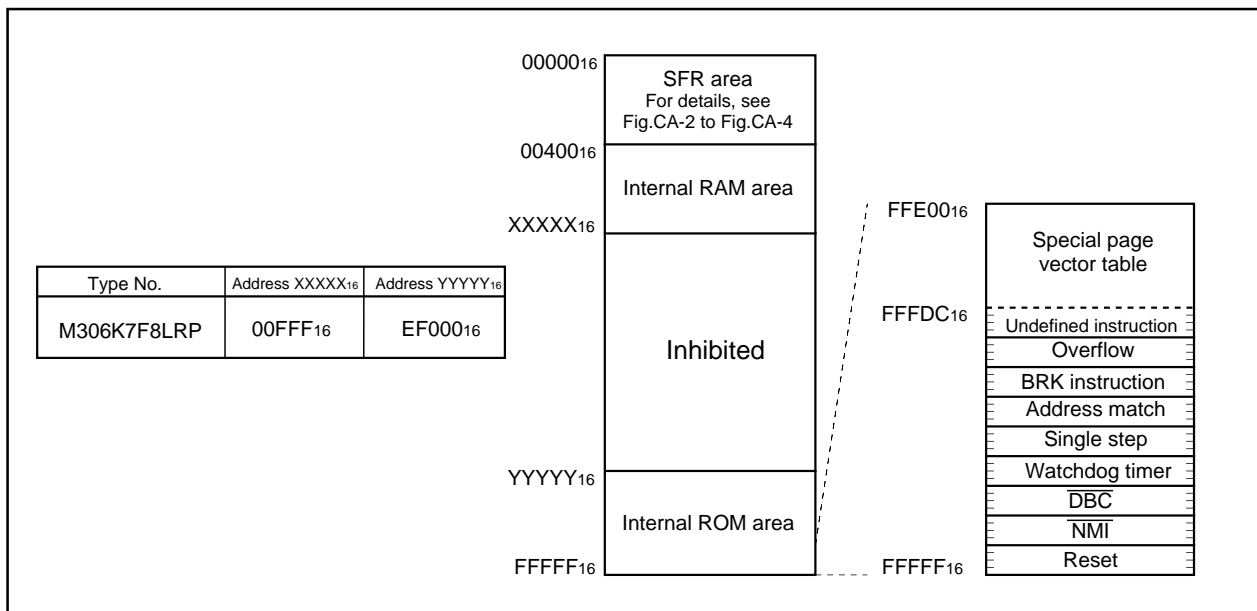
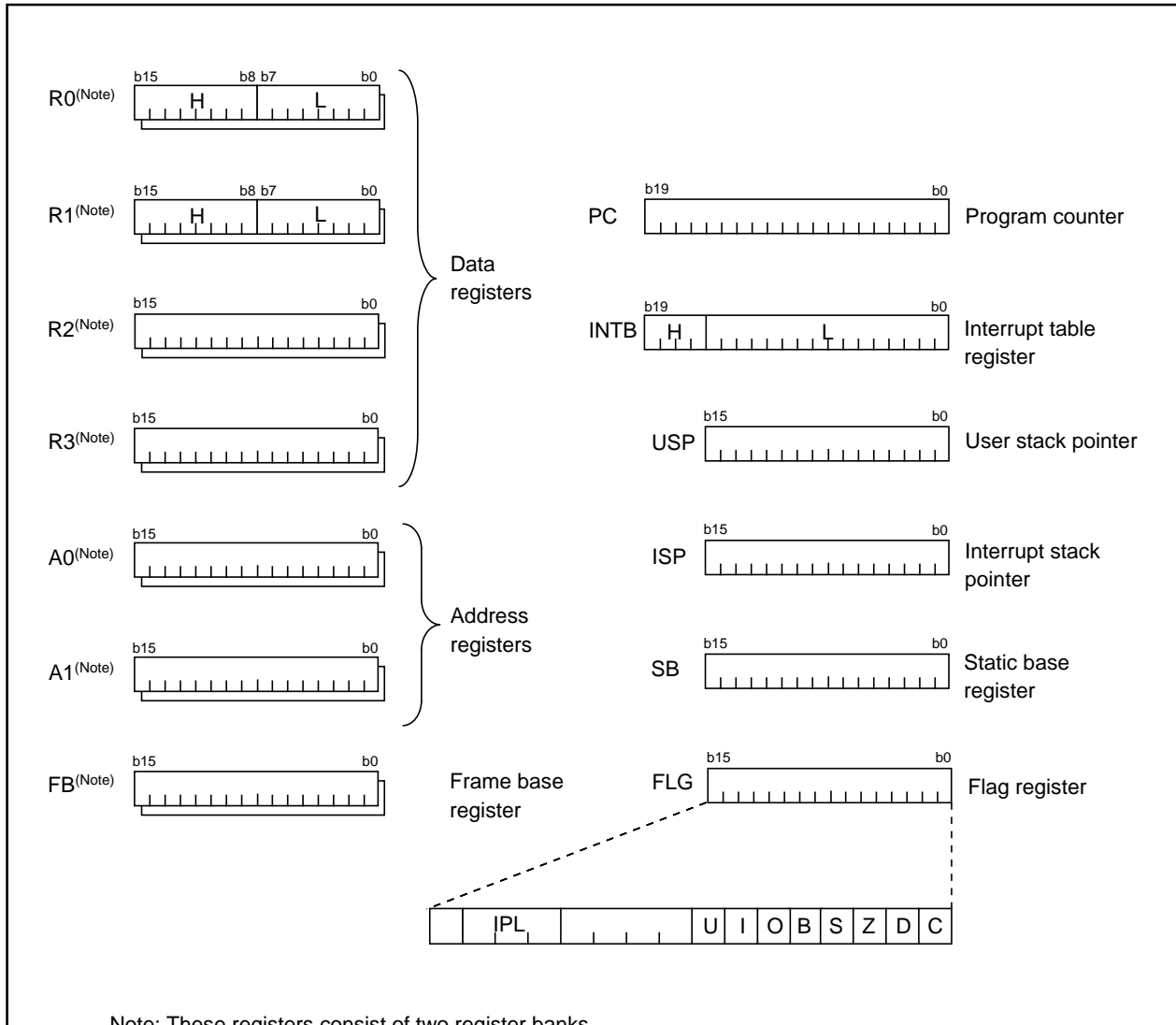

Fig.CA-1 Memory map

## Central Processing Unit (CPU)

The CPU has a total of 13 registers shown in Fig.BA-1. Seven of these registers (R0, R1, R2, R3, A0, A1, and FB) come in two sets; therefore, these have two register banks.



**Fig.BA-1 Central processing unit register**

### (1) Data registers (R0, R0H, R0L, R1, R1H, R1L, R2, and R3)

Data registers (R0, R1, R2, and R3) are configured with 16 bits, and are used primarily for transfer and arithmetic/logic operations.

Registers R0 and R1 each can be used as separate 8-bit data registers, high-order bits as (R0H/R1H), and low-order bits as (R0L/R1L). In some instructions, registers R2 and R0, as well as R3 and R1 can use as 32-bit data registers (R2R0/R3R1).

### (2) Address registers (A0 and A1)

Address registers (A0 and A1) are configured with 16 bits, and have functions equivalent to those of data registers. These registers can also be used for address register indirect addressing and address register relative addressing.

In some instructions, registers A1 and A0 can be combined for use as a 32-bit address register (A1A0).

**(3) Frame base register (FB)**

Frame base register (FB) is configured with 16 bits, and is used for FB relative addressing.

**(4) Program counter (PC)**

Program counter (PC) is configured with 20 bits, indicating the address of an instruction to be executed.

**(5) Interrupt table register (INTB)**

Interrupt table register (INTB) is configured with 20 bits, indicating the start address of an interrupt vector table.

**(6) Stack pointer (USP/ISP)**

Stack pointer comes in two types: user stack pointer (USP) and interrupt stack pointer (ISP), each configured with 16 bits.

Your desired type of stack pointer (USP or ISP) can be selected by a stack pointer select flag (U flag). This flag is located at the position of bit 7 in the flag register (FLG).

**(7) Static base register (SB)**

Static base register (SB) is configured with 16 bits, and is used for SB relative addressing.

**(8) Flag register (FLG)**

Flag register (FLG) is configured with 11 bits, each bit is used as a flag. Fig.BA-2 shows the flag register (FLG). The following explains the function of each flag:

- Bit 0: Carry flag (C flag)

This flag retains a carry, borrow, or shift-out bit that has occurred in the arithmetic/logic unit.

- Bit 1: Debug flag (D flag)

This flag enables a single-step interrupt.

When this flag is "1", a single-step interrupt is generated after instruction execution. This flag is cleared to "0" when the interrupt is acknowledged.

- Bit 2: Zero flag (Z flag)

This flag is set to "1" when an arithmetic operation resulted in 0; otherwise, cleared to "0".

- Bit 3: Sign flag (S flag)

This flag is set to "1" when an arithmetic operation resulted in a negative value; otherwise, cleared to "0".

- Bit 4: Register bank select flag (B flag)

This flag chooses a register bank. Register bank 0 is selected when this flag is "0"; register bank 1 is selected when this flag is "1".

- Bit 5: Overflow flag (O flag)

This flag is set to "1" when an arithmetic operation resulted in overflow; otherwise, cleared to "0".

- Bit 6: Interrupt enable flag (I flag)

This flag enables a maskable interrupt.

An interrupt is disabled when this flag is "0", and is enabled when this flag is "1". This flag is cleared to "0" when the interrupt is acknowledged.

- Bit 7: Stack pointer select flag (U flag)

Interrupt stack pointer (ISP) is selected when this flag is “0” ; user stack pointer (USP) is selected when this flag is “1”.

This flag is cleared to “0” when a hardware interrupt is acknowledged or an INT instruction of software interrupt No. 0 to 31 is executed.

- Bits 8 to 11: Reserved area
- Bits 12 to 14: Processor interrupt priority level (IPL)

Processor interrupt priority level (IPL) is configured with the three bits, for specification of up to eight processor interrupt priority levels from level 0 to level 7.

If a requested interrupt has priority greater than the processor interrupt priority level (IPL), the interrupt is enabled.

- Bit 15: Reserved area

The C, Z, S, and O flags are changed when instructions are executed. See the software manual for details.

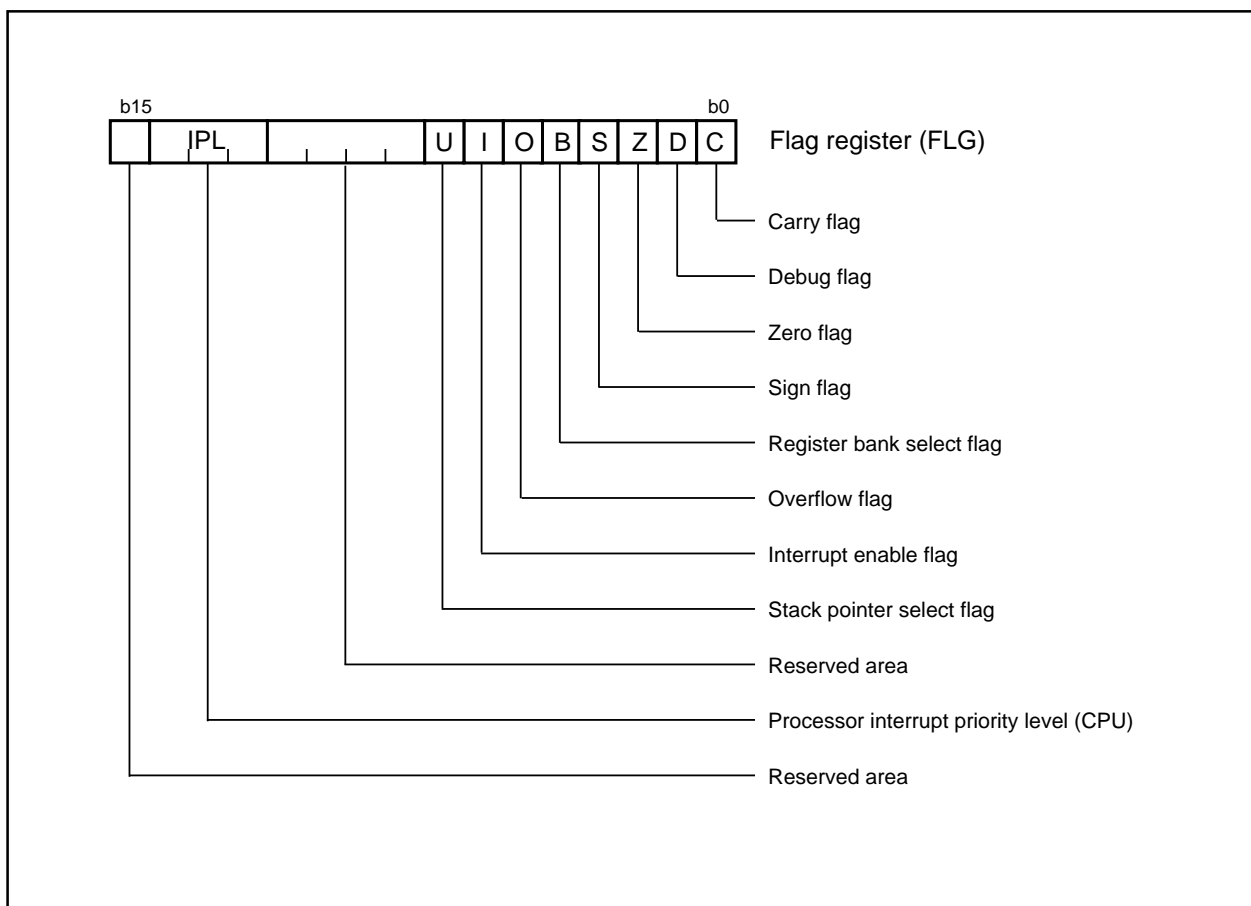

Fig.BA-2 Flag register (FLG)



**Reset**

There are two kinds of resets; hardware and software. In both cases, operation is the same after the reset. (See “Software Reset” for details of software resets.) This section explains the hardware reset.

When the supply voltage is in the range where operation is guaranteed, a reset is effected by holding the reset pin level “L” (0.2V<sub>CC</sub> max.) for at least 20 cycles. When the reset pin level is then returned to the “H” level while main clock is stable, the reset status is cancelled and program execution resumes from the address in the reset vector table.

Fig.VB-1 shows the example reset circuit. Fig.VB-2 shows the reset sequence.

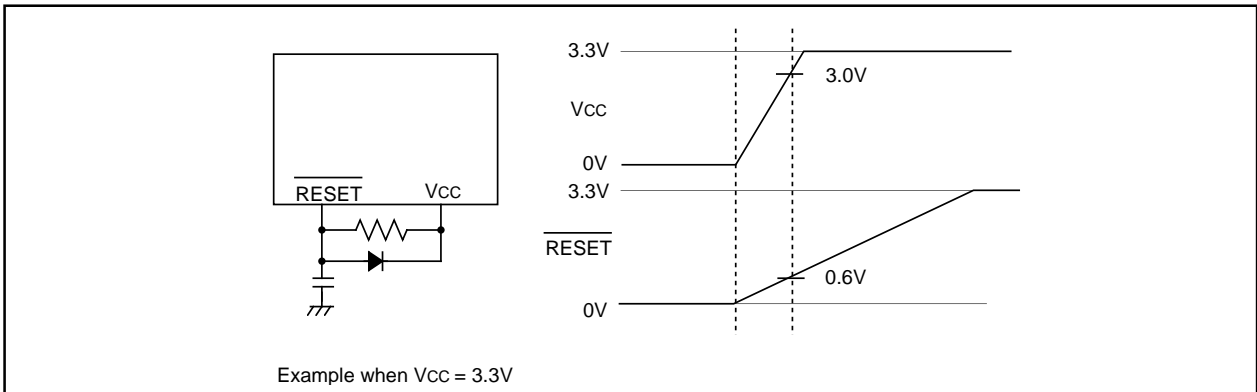

**Fig.VB-1 Example reset circuit**

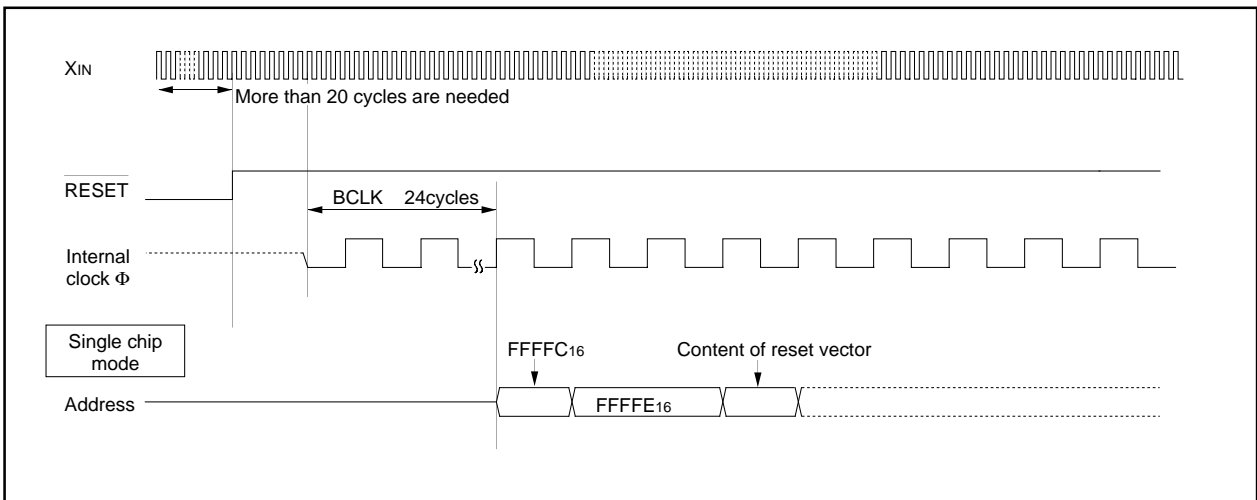

**Fig.VB-2 Reset sequence**

Table VB-1 shows the statuses of the other pins while the  $\overline{\text{RESET}}$  pin level is "L". Fig.VB-3 and VB-4 show the internal status of the microcomputer immediately after the reset is cancelled.

**Table VB-1 Pin status when  $\overline{\text{RESET}}$  pin level is "L"**

Pin name	Status
	CNV <sub>SS</sub> = V <sub>SS</sub> (M <sub>0</sub> )
P0	I/O port (floating)
P1	I/O port (floating)
P2, P3, P40 to P43	I/O port (floating)
P44	I/O port (floating)
P45 to P47	I/O port (floating)
P50	I/O port (floating)
P51	I/O port (floating)
P52	I/O port (floating)
P53	I/O port (floating)
P54	I/O port (floating)
P55	I/O port (floating)
P56	I/O port (floating)
P57	I/O port (floating)
P6, P7, P80 to P84, P86, P87, P9, P10	I/O port (floating)
P11, P12, P13, P14	I/O port (floating)
P15, P16	I/O port (floating)

(1) Processor mode register 0	(000416)...	0016	(24)UART2 receive interrupt control register	(005016)...	XXXXXXXX?000
(2) Processor mode register 1	(000516)...	000000XX0	(25)UART0 transmit interrupt control register	(005116)...	XXXXXXXX?000
(3) System clock control register 0	(000616)...	010010000	(26)UART0 receive interrupt control register	(005216)...	XXXX00?000
(4) System clock control register 1	(000716)...	001000000	(27)UART1 transmit interrupt control register	(005316)...	XXXXXXXX?000
(5) Address match interrupt enable register	(000916)...	XXXXXXXX00	(28)UART1 receive interrupt control register	(005416)...	XXXX00?000
(6) Protect register	(000A16)...	XXXXXXXX00	(29)Timer A0 interrupt control register	(005516)...	XXXX00?000
(7) Watchdog timer control register	(000F16)...	0000???	(30)Timer A1 interrupt control register	(005616)...	XXXX00?000
(8) Address match interrupt register 0	(001016)...	0016	(31)Timer A2 interrupt control register	(005716)...	XXXXXXXX?000
	(001116)...	0016	(32)Timer A3 interrupt control register	(005816)...	XXXXXXXX?000
	(001216)...	XXXXXXXX0000	(33)Timer A4 interrupt control register	(005916)...	XXXXXXXX?000
(9) Address match interrupt register 1	(001416)...	0016	(34)Timer B0 interrupt control register	(005A16)...	XXXX00?000
	(001516)...	0016	(35)Timer B1 interrupt control register	(005B16)...	XXXX00?000
	(001616)...	XXXXXXXX0000	(36)Timer B2 interrupt control register	(005C16)...	XXXXXXXX?000
(10)DMA0 control register	(002C16)...	000000?00	(37)INT0 interrupt control register	(005D16)...	XXXX00?000
(11)DMA1 control register	(003C16)...	000000?00	(38)INT1 interrupt control register	(005E16)...	XXXX00?000
(12)INT3 interrupt control register	(004416)...	XXXX00?000	(39)INT2 interrupt control register	(005F16)...	XXXX00?000
(13)Timer B5 interrupt control register	(004516)...	XXXXXXXX?000	(40)PS20 shift register	(02A016)...	0016
(14)Timer B4 interrupt control register	(004616)...	XXXXXXXX?000	(41)PS20 status register	(02A116)...	0016
(15)Timer B3 interrupt control register	(004716)...	XXXXXXXX?000	(42)PS20 control register	(02A216)...	0016
(16)SI/O4 interrupt control register	(004816)...	XXXX00?000	(43)PS21 shift register	(02A416)...	0016
(17)SI/O3 interrupt control register	(004916)...	XXXX00?000	(44)PS21 status register	(02A516)...	0016
(18)Bus collision detection interrupt control register	(004A16)...	XXXXXXXX?000	(45)PS21 control register	(02A616)...	0016
(19)DMA0 interrupt control register	(004B16)...	XXXX00?000	(46)PS22 shift register	(02A816)...	0016
(20)DMA1 interrupt control register	(004C16)...	XXXX00?000	(47)PS22 status register	(02A916)...	0016
(21)Key input interrupt control register 0	(004D16)...	XXXXXXXX?000	(48)PS22 control register	(02AA16)...	0016
(22)A-D conversion interrupt control register	(004E16)...	XXXXXXXX?000	(49)PS2 mode register	(02AC16)...	0016
(23)UART2 transmit interrupt control register	(004F16)...	XXXXXXXX?000			

x : Nothing is mapped to this bit  
 ? : Undefined  
 The content of other registers and RAM is undefined when the microcomputer is reset. The initial values must therefore be set.

**Fig.VB-3 Device's internal status after a reset is cleared (1)**

(50) Data bus buffer status register 0	(02C1 <sub>16</sub> )... 00 <sub>16</sub>	(76) PWM control register 1	(0309 <sub>16</sub> )... 00 <sub>16</sub>
(51) Data bus buffer status register 1	(02C3 <sub>16</sub> )... 00 <sub>16</sub>	(77) I <sup>2</sup> C0 address register	(0322 <sub>16</sub> )... 00 <sub>16</sub>
(52) Data bus buffer status register 2	(02C5 <sub>16</sub> )... 00 <sub>16</sub>	(78) I <sup>2</sup> C0 control register	(0323 <sub>16</sub> )... 00 <sub>16</sub>
(53) Data bus buffer status register 3	(02C7 <sub>16</sub> )... 00 <sub>16</sub>	(79) I <sup>2</sup> C0 clock control register	(0324 <sub>16</sub> )... 00 <sub>16</sub>
(54) ISA bus control register 0	(02C8 <sub>16</sub> )... 00 <sub>16</sub>	(80) I <sup>2</sup> C0 start/stop condition control register	(0325 <sub>16</sub> )... 1A <sub>16</sub>
(55) ISA bus control register 1	(02C9 <sub>16</sub> )... 00 <sub>16</sub>	(81) I <sup>2</sup> C0 control register 1	(0326 <sub>16</sub> )... 30 <sub>16</sub>
(56) GateA20 control register	(02CA <sub>16</sub> )... 00 <sub>16</sub>	(82) I <sup>2</sup> C0 control register 2	(0327 <sub>16</sub> )... 00 <sub>16</sub>
(57) Port P11 direction register	(02E2 <sub>16</sub> )... 00 <sub>16</sub>	(83) I <sup>2</sup> C0 status register	(0328 <sub>16</sub> )... 00100000
(58) Port P12 direction register	(02E3 <sub>16</sub> )... 00 <sub>16</sub>	(84) I <sup>2</sup> C1 address register	(0332 <sub>16</sub> )... 00 <sub>16</sub>
(59) Port P13 direction register	(02E6 <sub>16</sub> )... 00 <sub>16</sub>	(85) I <sup>2</sup> C1 control register	(0333 <sub>16</sub> )... 00 <sub>16</sub>
(60) Port P14 direction register	(02E7 <sub>16</sub> )... 00 <sub>16</sub>	(86) I <sup>2</sup> C1 clock control register	(0334 <sub>16</sub> )... 00 <sub>16</sub>
(61) Port P15 direction register	(02EA <sub>16</sub> )... 00 <sub>16</sub>	(87) I <sup>2</sup> C1 start/stop condition control register	(0335 <sub>16</sub> )... 1A <sub>16</sub>
(62) Port P16 direction register	(02EB <sub>16</sub> )... XXXXXXXX00	(88) I <sup>2</sup> C1 control register 1	(0336 <sub>16</sub> )... 30 <sub>16</sub>
(63) Port function selection register 0	(02F8 <sub>16</sub> )... 00 <sub>16</sub>	(89) I <sup>2</sup> C1 control register 2	(0337 <sub>16</sub> )... 00 <sub>16</sub>
(64) Port function selection register 1	(02F9 <sub>16</sub> )... 00 <sub>16</sub>	(90) I <sup>2</sup> C1 status register	(0338 <sub>16</sub> )... 00100000
(65) Port P4 input register	(02FA <sub>16</sub> )... 0XXXXXXXXX	(91) TimerB3,4,5 count start flag	(0340 <sub>16</sub> )... 000XXXXXXXXX
(66) Port P7 input register	(02FB <sub>16</sub> )... 00XXXXXXXXX	(92) Interrupt factor selection register 1	(0356 <sub>16</sub> )... 00 <sub>16</sub>
(67) Pull-up control register 3	(02FC <sub>16</sub> )... 00 <sub>16</sub>	(93) Interrupt factor selection register 2	(0357 <sub>16</sub> )... 00 <sub>16</sub>
(68) Pull-up control register 4	(02FD <sub>16</sub> )... 00 <sub>16</sub>	(94) Interrupt factor selection register 3	(0358 <sub>16</sub> )... 00 <sub>16</sub>
(69) Port control register 1	(02FE <sub>16</sub> )... 00 <sub>16</sub>	(95) Interrupt factor selection register 4	(0359 <sub>16</sub> )... 00 <sub>16</sub>
(70) Port control register 2	(02FF <sub>16</sub> )... 00 <sub>16</sub>	(96) TimerB3 mode register	(035B <sub>16</sub> )... 00?XXXX000
(71) PWM0L register	(0301 <sub>16</sub> )... XXXXXXXXXX	(97) TimerB4 mode register	(035C <sub>16</sub> )... 00?XXXX000
(72) PWM1L register	(0303 <sub>16</sub> )... XXXXXXXXXX	(98) TimerB5 mode register	(035D <sub>16</sub> )... 00?XXXX000
(73) PWM2L register	(0305 <sub>16</sub> )... XXXXXXXXXX	(99) Interrupt factor selection register 0	(035F <sub>16</sub> )... 00 <sub>16</sub>
(74) PWM3L register	(0307 <sub>16</sub> )... XXXXXXXXXX	(100) SI/O3 control register	(0362 <sub>16</sub> )... 40 <sub>16</sub>
(75) PWM control register 0	(0308 <sub>16</sub> )... 00 <sub>16</sub>	(101) SI/O4 control register	(0366 <sub>16</sub> )... 40 <sub>16</sub>

x : Nothing is mapped to this bit  
? : Undefined

The content of other registers and RAM is undefined when the microcomputer is reset. The initial values must therefore be set.

Fig.VB-4 Device's internal status after a reset is cleared (2)

(102) UART2 special mode register	(0377 <sub>16</sub> )...	00 <sub>16</sub>	(130) A-D control register 0	(03D6 <sub>16</sub> )...	0 0 0 0 0 ? ? ?
(103) UART2 transmit/receive mode register	(0378 <sub>16</sub> )...	00 <sub>16</sub>	(131) A-D control register 1	(03D7 <sub>16</sub> )...	00 <sub>16</sub>
(104) UART2 transmit/receive control register 0	(037C <sub>16</sub> )...	0 0 0 0 1 0 0 0	(132) D-A control register	(03DC <sub>16</sub> )...	00 <sub>16</sub>
(105) UART2 transmit/receive control register 1	(037D <sub>16</sub> )...	0 0 0 0 0 0 1 0	(133) Comparator control register	(03DE <sub>16</sub> )...	00 <sub>16</sub>
(106) Count start flag	(0380 <sub>16</sub> )...	00 <sub>16</sub>	(134) Port P0 direction register	(03E2 <sub>16</sub> )...	00 <sub>16</sub>
(107) Clock prescaler reset flag	(0381 <sub>16</sub> )...	0 x x x x x x x	(135) Port P1 direction register	(03E3 <sub>16</sub> )...	00 <sub>16</sub>
(108) One-shot start flag	(0382 <sub>16</sub> )...	0 0 x 0 0 0 0 0	(136) Port P2 direction register	(03E6 <sub>16</sub> )...	00 <sub>16</sub>
(109) Trigger select flag	(0383 <sub>16</sub> )...	00 <sub>16</sub>	(137) Port P3 direction register	(03E7 <sub>16</sub> )...	00 <sub>16</sub>
(110) Up-down flag	(0384 <sub>16</sub> )...	00 <sub>16</sub>	(138) Port P4 direction register	(03EA <sub>16</sub> )...	00 <sub>16</sub>
(111) Timer A0 mode register	(0396 <sub>16</sub> )...	00 <sub>16</sub>	(139) Port P5 direction register	(03EB <sub>16</sub> )...	00 <sub>16</sub>
(112) Timer A1 mode register	(0397 <sub>16</sub> )...	00 <sub>16</sub>	(140) Port P6 direction register	(03EE <sub>16</sub> )...	00 <sub>16</sub>
(113) Timer A2 mode register	(0398 <sub>16</sub> )...	00 <sub>16</sub>	(141) Port P7 direction register	(03EF <sub>16</sub> )...	00 <sub>16</sub>
(114) Timer A3 mode register	(0399 <sub>16</sub> )...	00 <sub>16</sub>	(142) Port P8 direction register	(03F2 <sub>16</sub> )...	0 0 x 0 0 0 0 0
(115) Timer A4 mode register	(039A <sub>16</sub> )...	00 <sub>16</sub>	(143) Port P9 direction register	(03F3 <sub>16</sub> )...	00 <sub>16</sub>
(116) Timer B0 mode register	(039B <sub>16</sub> )...	0 0 ? x 0 0 0 0	(144) Port P10 direction register	(03F6 <sub>16</sub> )...	00 <sub>16</sub>
(117) Timer B1 mode register	(039C <sub>16</sub> )...	0 0 ? x 0 0 0 0	(145) Pull-up control register 0	(03FC <sub>16</sub> )...	00 <sub>16</sub>
(118) Timer B2 mode register	(039D <sub>16</sub> )...	0 0 ? x 0 0 0 0	(146) Pull-up control register 1	(03FD <sub>16</sub> )...	00 <sub>16</sub>
(119) UART0 transmit/receive mode register	(03A0 <sub>16</sub> )...	00 <sub>16</sub>	(147) Pull-up control register 2	(03FE <sub>16</sub> )...	00 <sub>16</sub>
(120) UART0 transmit/receive control register 0	(03A4 <sub>16</sub> )...	0 0 0 0 1 0 0 0	(148) Port control register 0	(03FF <sub>16</sub> )...	00 <sub>16</sub>
(121) UART0 transmit/receive control register 1	(03A5 <sub>16</sub> )...	0 0 0 0 0 0 1 0	(149) Data registers (R0/R1/R2/R3)		0000 <sub>16</sub>
(122) UART1 transmit/receive mode register	(03A8 <sub>16</sub> )...	00 <sub>16</sub>	(150) Address registers (A0/A1)		0000 <sub>16</sub>
(123) UART1 transmit/receive control register 0	(03AC <sub>16</sub> )...	0 0 0 0 1 0 0 0	(151) Frame base register (FB)		0000 <sub>16</sub>
(124) UART1 transmit/receive control register 1	(03AD <sub>16</sub> )...	0 0 0 0 0 0 1 0	(152) Interrupt table register (INTB)		00000 <sub>16</sub>
(125) UART transmit/receive control register 2	(03B0 <sub>16</sub> )...	x 0 0 0 0 0 0 0	(153) User stack pointer (USP)		0000 <sub>16</sub>
(126) Flash memory recognition register	(03B4 <sub>16</sub> )...	0 0 0 0 0 0 0 0	(154) Interrupt stack pointer (ISP)		0000 <sub>16</sub>
(127) Flash memory control register	(03B7 <sub>16</sub> )...	x x x x 0 0 0 1	(155) Static base register (SB)		0000 <sub>16</sub>
(128) DMA0 cause select register	(03B8 <sub>16</sub> )...	00 <sub>16</sub>	(156) Flag register (FLG)		0000 <sub>16</sub>
(129) DMA1 cause select register	(03BA <sub>16</sub> )...	00 <sub>16</sub>			

x : Nothing is mapped to this bit  
? : Undefined

The content of other registers and RAM is undefined when the microcomputer is reset. The initial values must therefore be set.

Fig.VB-5 Device's internal status after a reset is cleared (3)

(157) Serial interrupt control register 0	(02B0 <sub>16</sub> )...	00 <sub>16</sub>
(158) Serial interrupt control register 1	(02B1 <sub>16</sub> )...	00 <sub>16</sub>
(159) IRQ request register 0	(02B2 <sub>16</sub> )...	00 <sub>16</sub>
(160) IRQ request register 1	(02B3 <sub>16</sub> )...	00 <sub>16</sub>
(161) IRQ request register 2	(02B4 <sub>16</sub> )...	00 <sub>16</sub>
(162) IRQ request register 3	(02B5 <sub>16</sub> )...	00 <sub>16</sub>
(163) IRQ request register 4	(02B6 <sub>16</sub> )...	00 <sub>16</sub>
(164) LPC1 address register L	(02D0 <sub>16</sub> )...	00 <sub>16</sub>
(165) LPC1 address register H	(02D1 <sub>16</sub> )...	00 <sub>16</sub>
(166) LPC2 address register L	(02D2 <sub>16</sub> )...	00 <sub>16</sub>
(167) LPC2 address register H	(02D3 <sub>16</sub> )...	00 <sub>16</sub>
(168) LPC3 address register L	(02D4 <sub>16</sub> )...	00 <sub>16</sub>
(169) LPC3 address register H	(02D5 <sub>16</sub> )...	00 <sub>16</sub>
(170) LPC control register	(02D6 <sub>16</sub> )...	00 <sub>16</sub>

The content of other registers and RAM is undefined when the microcomputer is reset. The initial values must therefore be set.

Fig.VB-6 Device's internal status after a reset is cleared (2)



0280 <sub>16</sub>		02C0 <sub>16</sub>	Data bus buffer register0 (DBB0)
0281 <sub>16</sub>		02C1 <sub>16</sub>	Data bus buffer status register0 (DBBSTS0)
0282 <sub>16</sub>		02C2 <sub>16</sub>	Data bus buffer register1 (DBB1)
0283 <sub>16</sub>		02C3 <sub>16</sub>	Data bus buffer status register1 (DBBSTS1)
0284 <sub>16</sub>		02C4 <sub>16</sub>	Data bus buffer register2 (DBB2)
0285 <sub>16</sub>		02C5 <sub>16</sub>	Data bus buffer status register2 (DBBSTS2)
0286 <sub>16</sub>		02C6 <sub>16</sub>	Data bus buffer register3 (DBB3)
0287 <sub>16</sub>		02C7 <sub>16</sub>	Data bus buffer status register3 (DBBSTS3)
0288 <sub>16</sub>		02C8 <sub>16</sub>	ISA control register0 (DBBCON0)
0289 <sub>16</sub>		02C9 <sub>16</sub>	ISA control register1 (DBBCON1)
028A <sub>16</sub>		02CA <sub>16</sub>	Gate A20 control register (GA20CON)
028B <sub>16</sub>		02CB <sub>16</sub>	
028C <sub>16</sub>		02CC <sub>16</sub>	
028D <sub>16</sub>		02CD <sub>16</sub>	
028E <sub>16</sub>		02CE <sub>16</sub>	
028F <sub>16</sub>		02CF <sub>16</sub>	
0290 <sub>16</sub>		02D0 <sub>16</sub>	LPC1 address registerL (LPC1ADL)
0291 <sub>16</sub>		02D1 <sub>16</sub>	LPC1 address registerH (LPC1ADH)
0292 <sub>16</sub>		02D2 <sub>16</sub>	LPC2 address registerL (LPC2ADL)
0293 <sub>16</sub>		02D3 <sub>16</sub>	LPC2 address registerH (LPC2ADH)
0294 <sub>16</sub>		02D4 <sub>16</sub>	LPC3 address registerL (LPC3ADL)
0295 <sub>16</sub>		02D5 <sub>16</sub>	LPC3 address registerH (LPC3ADH)
0296 <sub>16</sub>		02D6 <sub>16</sub>	LPC control register (LPCCON)
0297 <sub>16</sub>		02D7 <sub>16</sub>	
0298 <sub>16</sub>		02D8 <sub>16</sub>	
0299 <sub>16</sub>		02D9 <sub>16</sub>	
029A <sub>16</sub>		02DA <sub>16</sub>	
029B <sub>16</sub>		02DB <sub>16</sub>	
029C <sub>16</sub>		02DC <sub>16</sub>	
029D <sub>16</sub>		02DD <sub>16</sub>	
029E <sub>16</sub>		02DE <sub>16</sub>	
029F <sub>16</sub>		02DF <sub>16</sub>	
02A0 <sub>16</sub>	PS20 shift register (PS20SR)	02E0 <sub>16</sub>	Port P11 (P11)
02A1 <sub>16</sub>	PS20 status register (PS20STS)	02E1 <sub>16</sub>	Port P12 (P12)
02A2 <sub>16</sub>	PS20 control register (PS20CON)	02E2 <sub>16</sub>	Port P11 direction register (PD11)
02A3 <sub>16</sub>		02E3 <sub>16</sub>	Port P12 direction register (PD12)
02A4 <sub>16</sub>	PS21 shift register (PS21SR)	02E4 <sub>16</sub>	Port P13 (P13)
02A5 <sub>16</sub>	PS21 status register (PS21STS)	02E5 <sub>16</sub>	Port P14 (P14)
02A6 <sub>16</sub>	PS21 control register (PS21CON)	02E6 <sub>16</sub>	Port P13 direction register (PD13)
02A7 <sub>16</sub>		02E7 <sub>16</sub>	Port P14 direction register (PD14)
02A8 <sub>16</sub>	PS22 shift register (PS22SR)	02E8 <sub>16</sub>	Port P15 (P15)
02A9 <sub>16</sub>	PS22 status register (PS22STS)	02E9 <sub>16</sub>	Port P16 (P16)
02AA <sub>16</sub>	PS22 control register (PS22CON)	02EA <sub>16</sub>	Port P15 direction register (PD15)
02AB <sub>16</sub>		02EB <sub>16</sub>	Port P16 direction register (PD16)
02AC <sub>16</sub>	PS2 mode register (PS2MOD)	02EC <sub>16</sub>	
02AD <sub>16</sub>		02ED <sub>16</sub>	
02AE <sub>16</sub>		02EE <sub>16</sub>	
02AF <sub>16</sub>		02EF <sub>16</sub>	
02B0 <sub>16</sub>	Serial Interrupt control register 0 (SERCON0)	02F0 <sub>16</sub>	
02B1 <sub>16</sub>	Serial Interrupt control register 1 (SERCON1)	02F1 <sub>16</sub>	
02B2 <sub>16</sub>	IRQ request register 0 (IRQ0)	02F2 <sub>16</sub>	
02B3 <sub>16</sub>	IRQ request register 1 (IRQ1)	02F3 <sub>16</sub>	
02B4 <sub>16</sub>	IRQ request register 2 (IRQ2)	02F4 <sub>16</sub>	
02B5 <sub>16</sub>	IRQ request register 3 (IRQ3)	02F5 <sub>16</sub>	
02B6 <sub>16</sub>	IRQ request register 4 (IRQ4)	02F6 <sub>16</sub>	P14 event register (P14EV)
02B7 <sub>16</sub>		02F7 <sub>16</sub>	Port control register3 (PCR3)
02B8 <sub>16</sub>		02F8 <sub>16</sub>	Port function selection register0 (PSL0)
02B9 <sub>16</sub>		02F9 <sub>16</sub>	Port function selection register1 (PSL1)
02BA <sub>16</sub>		02FA <sub>16</sub>	Port P4 input register (P4PIN)
02BB <sub>16</sub>		02FB <sub>16</sub>	Port P7 input register (P7PIN)
02BC <sub>16</sub>		02FC <sub>16</sub>	Pull-up control register3 (PUR3)
02BD <sub>16</sub>		02FD <sub>16</sub>	Pull-up control register4 (PUR4)
02BE <sub>16</sub>		02FE <sub>16</sub>	Port control register1 (PCR1)
02BF <sub>16</sub>		02FF <sub>16</sub>	Port control register2 (PCR2)

Note 1: The areas that nothing are allocated in SFR are reserved. Read and Write to the areas are inhibited.

Fig.CA-3 Location of peripheral unit control registers (2)



0300 <sub>16</sub>	PWM0H register (PWM0H)	0340 <sub>16</sub>	TimerB3,4,5 count start flag (TBSR)
0301 <sub>16</sub>	PWM0L register (PWM0L)	0341 <sub>16</sub>	
0302 <sub>16</sub>	PWM1H register (PWM1H)	0342 <sub>16</sub>	
0303 <sub>16</sub>	PWM1L register (PWM1L)	0343 <sub>16</sub>	
0304 <sub>16</sub>	PWM2H register (PWM2H)	0344 <sub>16</sub>	
0305 <sub>16</sub>	PWM2L register (PWM2L)	0345 <sub>16</sub>	
0306 <sub>16</sub>	PWM3H register (PWM3H)	0346 <sub>16</sub>	
0307 <sub>16</sub>	PWM3L register (PWM3L)	0347 <sub>16</sub>	
0308 <sub>16</sub>	PWM control register0 (PWMCON0)	0348 <sub>16</sub>	
0309 <sub>16</sub>	PWM control register1 (PWMCON1)	0349 <sub>16</sub>	
030A <sub>16</sub>		034A <sub>16</sub>	
030B <sub>16</sub>		034B <sub>16</sub>	
030C <sub>16</sub>		034C <sub>16</sub>	
030D <sub>16</sub>		034D <sub>16</sub>	
030E <sub>16</sub>		034E <sub>16</sub>	
030F <sub>16</sub>		034F <sub>16</sub>	
0310 <sub>16</sub>		0350 <sub>16</sub>	TimerB3 register (TB3)
0311 <sub>16</sub>		0351 <sub>16</sub>	
0312 <sub>16</sub>		0352 <sub>16</sub>	TimerB4 register (TB4)
0313 <sub>16</sub>		0353 <sub>16</sub>	
0314 <sub>16</sub>		0354 <sub>16</sub>	TimerB5 register (TB5)
0315 <sub>16</sub>		0355 <sub>16</sub>	
0316 <sub>16</sub>		0356 <sub>16</sub>	Interrupt event select register1 (IFSR1)
0317 <sub>16</sub>		0357 <sub>16</sub>	Interrupt event select register2 (IFSR2)
0318 <sub>16</sub>		0358 <sub>16</sub>	Interrupt event select register3 (IFSR3)
0319 <sub>16</sub>		0359 <sub>16</sub>	Interrupt event select register4 (IFSR4)
031A <sub>16</sub>		035A <sub>16</sub>	
031B <sub>16</sub>		035B <sub>16</sub>	TimerB3 mode register (TB3MR)
031C <sub>16</sub>		035C <sub>16</sub>	TimerB4 mode register (TB4MR)
031D <sub>16</sub>		035D <sub>16</sub>	TimerB5 mode register (TB5MR)
031E <sub>16</sub>		035E <sub>16</sub>	
031F <sub>16</sub>		035F <sub>16</sub>	Interrupt event select register0 (IFSR0)
0320 <sub>16</sub>	I <sup>2</sup> C0 data shift register (S00)	0360 <sub>16</sub>	SI/O3 transmit/receive register (S3TRR)
0321 <sub>16</sub>		0361 <sub>16</sub>	
0322 <sub>16</sub>	I <sup>2</sup> C0 address register (S0D0)	0362 <sub>16</sub>	SI/O3 control register (S3C)
0323 <sub>16</sub>	I <sup>2</sup> C0 control register0 (S1D0)	0363 <sub>16</sub>	SI/O3 communication speed register (S3BRG)
0324 <sub>16</sub>	I <sup>2</sup> C0 clock control register (S20)	0364 <sub>16</sub>	SI/O4 transmit/receive register (S4TRR)
0325 <sub>16</sub>	I <sup>2</sup> C0 start/stop condition control register (S2D0)	0365 <sub>16</sub>	
0326 <sub>16</sub>	I <sup>2</sup> C0 control register1 (S3D0)	0366 <sub>16</sub>	SI/O4 control register (S4C)
0327 <sub>16</sub>	I <sup>2</sup> C0 control register2 (S4D0)	0367 <sub>16</sub>	SI/O4 communication speed register (S4BRG)
0328 <sub>16</sub>	I <sup>2</sup> C0 status register (S10)	0368 <sub>16</sub>	
0329 <sub>16</sub>		0369 <sub>16</sub>	
032A <sub>16</sub>		036A <sub>16</sub>	
032B <sub>16</sub>		036B <sub>16</sub>	
032C <sub>16</sub>		036C <sub>16</sub>	
032D <sub>16</sub>		036D <sub>16</sub>	
032E <sub>16</sub>		036E <sub>16</sub>	
032F <sub>16</sub>		036F <sub>16</sub>	
0330 <sub>16</sub>	I <sup>2</sup> C1 data shift register (S01)	0370 <sub>16</sub>	
0331 <sub>16</sub>		0371 <sub>16</sub>	
0332 <sub>16</sub>	I <sup>2</sup> C1 address register (S0D1)	0372 <sub>16</sub>	
0333 <sub>16</sub>	I <sup>2</sup> C1 control register0 (S1D1)	0373 <sub>16</sub>	
0334 <sub>16</sub>	I <sup>2</sup> C1 clock control register (S21)	0374 <sub>16</sub>	
0335 <sub>16</sub>	I <sup>2</sup> C1 start/stop condition control register (S2D1)	0375 <sub>16</sub>	
0336 <sub>16</sub>	I <sup>2</sup> C1 control register1 (S3D1)	0376 <sub>16</sub>	
0337 <sub>16</sub>	I <sup>2</sup> C1 control register2 (S4D1)	0377 <sub>16</sub>	UART2 special mode register (U2SMR)
0338 <sub>16</sub>	I <sup>2</sup> C1 status register (S11)	0378 <sub>16</sub>	UART2 transmit/receive mode register (U2MR)
0339 <sub>16</sub>		0379 <sub>16</sub>	UART2 communication speed register (U2BRG)
033A <sub>16</sub>		037A <sub>16</sub>	UART2 transmit buffer register (U2TB)
033B <sub>16</sub>		037B <sub>16</sub>	
033C <sub>16</sub>		037C <sub>16</sub>	UART2 transmit/receive control register0 (U2C0)
033D <sub>16</sub>		037D <sub>16</sub>	UART2 transmit/receive control register1 (U2C1)
033E <sub>16</sub>		037E <sub>16</sub>	
033F <sub>16</sub>		037F <sub>16</sub>	UART2 receive buffer register (U2RB)

Note 1: The areas that nothing are allocated in SFR are reserved. Read and Write to the areas are inhibited.

Fig.CA-4 Location of peripheral unit control registers (3)

0380 <sup>16</sup>	Count start flag (TABSR)	03C0 <sup>16</sup>	A-D register0 (AD0)
0381 <sup>16</sup>	Clock prescaler reset flag (CPSRF)	03C1 <sup>16</sup>	
0382 <sup>16</sup>	One-shot start flag (ONSF)	03C2 <sup>16</sup>	A-D register1 (AD1)
0383 <sup>16</sup>	Trigger select register (TRGSR)	03C3 <sup>16</sup>	
0384 <sup>16</sup>	Up-down flag (UDF)	03C4 <sup>16</sup>	A-D register2 (AD2)
0385 <sup>16</sup>		03C5 <sup>16</sup>	
0386 <sup>16</sup>	TimerA0 (TA0)	03C6 <sup>16</sup>	A-D register3 (AD3)
0387 <sup>16</sup>		03C7 <sup>16</sup>	
0388 <sup>16</sup>	TimerA1 (TA1)	03C8 <sup>16</sup>	A-D register4 (AD4)
0389 <sup>16</sup>		03C9 <sup>16</sup>	
038A <sup>16</sup>	TimerA2 (TA2)	03CA <sup>16</sup>	A-D register5 (AD5)
038B <sup>16</sup>		03CB <sup>16</sup>	
038C <sup>16</sup>	TimerA3 (TA3)	03CC <sup>16</sup>	A-D register6 (AD6)
038D <sup>16</sup>		03CD <sup>16</sup>	
038E <sup>16</sup>	TimerA4 (TA4)	03CE <sup>16</sup>	A-D register7 (AD7)
038F <sup>16</sup>		03CF <sup>16</sup>	
0390 <sup>16</sup>	TimerB0 (TB0)	03D0 <sup>16</sup>	
0391 <sup>16</sup>		03D1 <sup>16</sup>	
0392 <sup>16</sup>	TimerB1 (TB1)	03D2 <sup>16</sup>	
0393 <sup>16</sup>		03D3 <sup>16</sup>	
0394 <sup>16</sup>	TimerB2 (TB2)	03D4 <sup>16</sup>	
0395 <sup>16</sup>		03D5 <sup>16</sup>	
0396 <sup>16</sup>	TimerA0 mode register (TA0MR)	03D6 <sup>16</sup>	A-D control register0 (ADCON0)
0397 <sup>16</sup>	TimerA1 mode register (TA1MR)	03D7 <sup>16</sup>	A-D control register1 (ADCON1)
0398 <sup>16</sup>	TimerA2 mode register (TA2MR)	03D8 <sup>16</sup>	D-A register0 (DA0)
0399 <sup>16</sup>	TimerA3 mode register (TA3MR)	03D9 <sup>16</sup>	
039A <sup>16</sup>	TimerA4 mode register (TA4MR)	03DA <sup>16</sup>	D-A register1 (DA1)
039B <sup>16</sup>	TimerB0 mode register (TB0MR)	03DB <sup>16</sup>	
039C <sup>16</sup>	TimerB1 mode register (TB1MR)	03DC <sup>16</sup>	D-A control register (DACON)
039D <sup>16</sup>	TimerB2 mode register (TB2MR)	03DD <sup>16</sup>	
039E <sup>16</sup>		03DE <sup>16</sup>	Comparator control register (CMPCON)
039F <sup>16</sup>		03DF <sup>16</sup>	Comparator data register (CMPD)
03A0 <sup>16</sup>	UART0 transmit/receive mode register (U0MR)	03E0 <sup>16</sup>	Port P0 (P0)
03A1 <sup>16</sup>	UART0 communication speed register (U0BRG)	03E1 <sup>16</sup>	Port P1 (P1)
03A2 <sup>16</sup>	UART0 transmit buffer register (U0TB)	03E2 <sup>16</sup>	Port P0 direction register (P0D)
03A3 <sup>16</sup>		03E3 <sup>16</sup>	Port P1 direction register (P1D)
03A4 <sup>16</sup>	UART0 transmit/receive control register0 (U0C0)	03E4 <sup>16</sup>	Port P2 (P2)
03A5 <sup>16</sup>	UART0 transmit/receive control register1 (U0C1)	03E5 <sup>16</sup>	Port P3 (P3)
03A6 <sup>16</sup>	UART0 receive buffer register (U0RB)	03E6 <sup>16</sup>	Port P2 direction register (P2D)
03A7 <sup>16</sup>		03E7 <sup>16</sup>	Port P3 direction register (P3D)
03A8 <sup>16</sup>	UART1 transmit/receive mode register (U1MR)	03E8 <sup>16</sup>	Port P4 (P4)
03A9 <sup>16</sup>	UART1 communication speed register (U1BRG)	03E9 <sup>16</sup>	Port P5 (P5)
03AA <sup>16</sup>	UART1 transmit buffer register (U1TB)	03EA <sup>16</sup>	Port P4 direction register (P4D)
03AB <sup>16</sup>		03EB <sup>16</sup>	Port P5 direction register (P5D)
03AC <sup>16</sup>	UART1 transmit/receive control register0 (U1C0)	03EC <sup>16</sup>	Port P6 (P6)
03AD <sup>16</sup>	UART1 transmit/receive control register1 (U1C1)	03ED <sup>16</sup>	Port P7 (P7)
03AE <sup>16</sup>	UART1 receive buffer register (U1RB)	03EE <sup>16</sup>	Port P6 direction register (P6D)
03AF <sup>16</sup>		03EF <sup>16</sup>	Port P7 direction register (P7D)
03B0 <sup>16</sup>	UART transmit/receive control register2 (U0CON)	03F0 <sup>16</sup>	Port P8 (P8)
03B1 <sup>16</sup>		03F1 <sup>16</sup>	Port P9 (P9)
03B2 <sup>16</sup>		03F2 <sup>16</sup>	Port P8 direction register (P8D)
03B3 <sup>16</sup>		03F3 <sup>16</sup>	Port P9 direction register (P9D)
03B4 <sup>16</sup>	Flash memory recognition register (FMRR)	03F4 <sup>16</sup>	Port P10 (P10)
03B5 <sup>16</sup>		03F5 <sup>16</sup>	
03B6 <sup>16</sup>		03F6 <sup>16</sup>	Port P10 direction register (P10D)
03B7 <sup>16</sup>	Flash memory control register (FMCR)	03F7 <sup>16</sup>	
03B8 <sup>16</sup>	DMA0 request cacse select register (DM0SL)	03F8 <sup>16</sup>	
03B9 <sup>16</sup>		03F9 <sup>16</sup>	
03BA <sup>16</sup>	DMA1 request cacse select register (DM1SL)	03FA <sup>16</sup>	
03BB <sup>16</sup>		03FB <sup>16</sup>	
03BC <sup>16</sup>		03FC <sup>16</sup>	Pull-up control register0 (PUR0)
03BD <sup>16</sup>		03FD <sup>16</sup>	Pull-up control register1 (PUR1)
03BE <sup>16</sup>		03FE <sup>16</sup>	Pull-up control register2 (PUR2)
03BF <sup>16</sup>		03FF <sup>16</sup>	Port control register0 (PCR0)

Note 1: The areas that nothing are allocated in SFR are reserved. Read and Write to the areas are inhibited.

Fig.CA-5 Location of peripheral unit control registers (4)

## Software Reset

Writing "1" to bit 3 of the processor mode register 0 (address 0004<sub>16</sub>) applies a (software) reset to the microcomputer. A software reset has almost the same effect as a hardware reset. The contents of internal RAM are retained.

## Processor Mode

### (1) Types of Processor Mode

The single-chip mode is supported in processor mode.

- Single-chip mode

In single-chip mode, only internal memory space (SFR, internal RAM, and internal ROM) can be accessed. Ports P0 to P16 can be used as programmable I/O ports or as I/O ports for the internal peripheral functions. Fig. BG-1 shows the structure of processor mode register 0 and processor mode register 1.

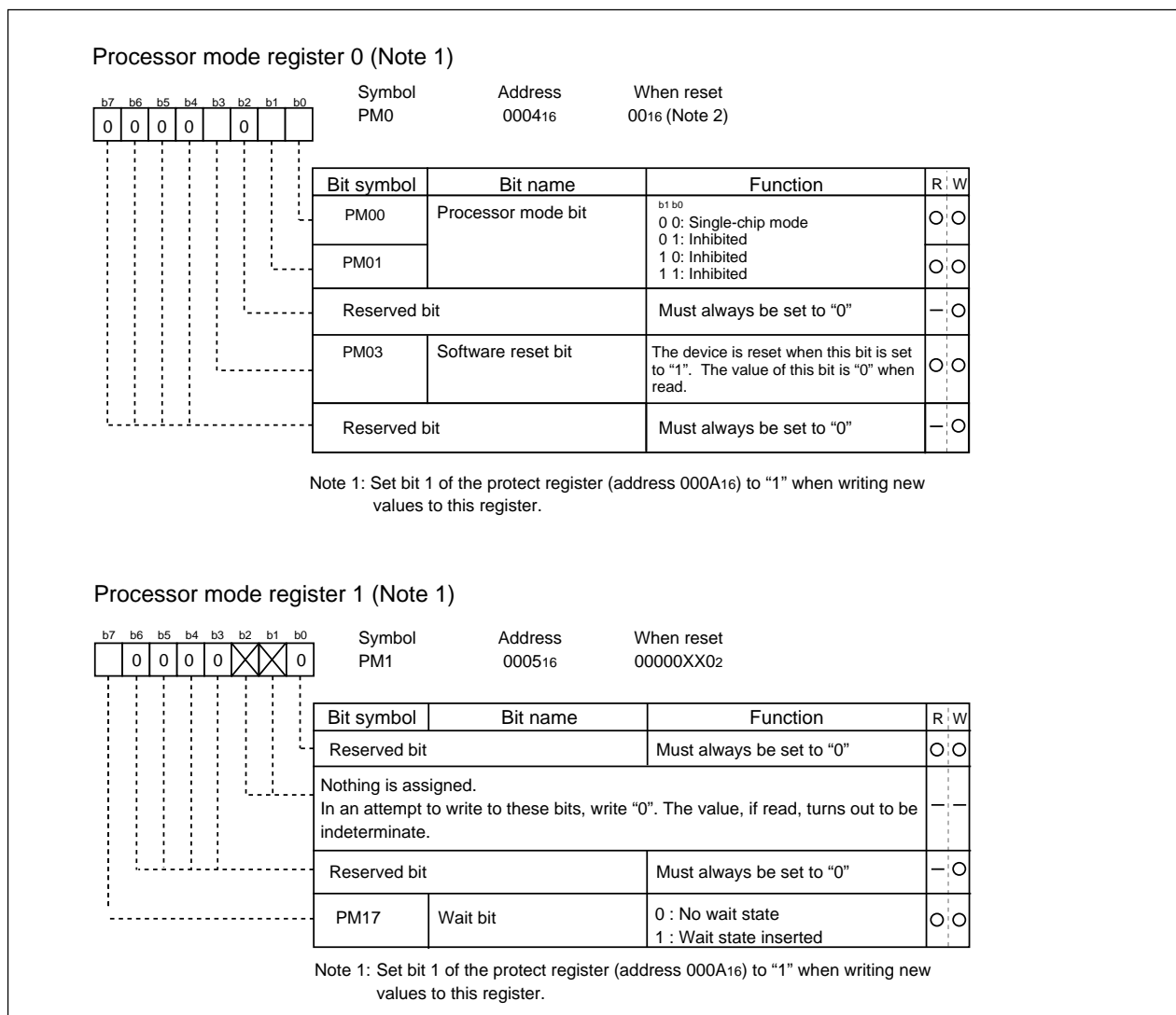

Fig.BG-1 Processor mode register 0 and 1

## Bus control

### (1) Software wait

A software wait can be inserted by setting the wait bit (bit 7) of the processor mode register 1 (address 0005<sub>16</sub>) (Note) .

A software wait is inserted in the internal ROM/RAM area by setting the wait bit of the processor mode register 1. When set to "0", each bus cycle is executed in one BCLK cycle. When set to "1", each bus cycle is executed in 2 BCLK cycles. After the microcomputer has been reset, this bit defaults to "0".

Set this bit after referring to the recommended operating conditions (main clock input oscillation frequency) of the electric characteristics.

The SFR area is always accessed in two BCLK cycles regardless of the setting of these control bits.

Table.EF-1 shows the software wait and bus cycles. Fig.EF-1 shows example bus timing when using software waits.

Note: Before attempting to change the contents of the processor mode register 1, set bit 1 of the protect register (address 000A<sub>16</sub>) to "1".

**Table.EF-1 Software waits and bus cycles**

Area	Wait bit	Bus cycle
SFR	Invalid	2 BCLK cycles
Internal ROM/RAM	0	1 BCLK cycle
	1	2 BCLK cycles

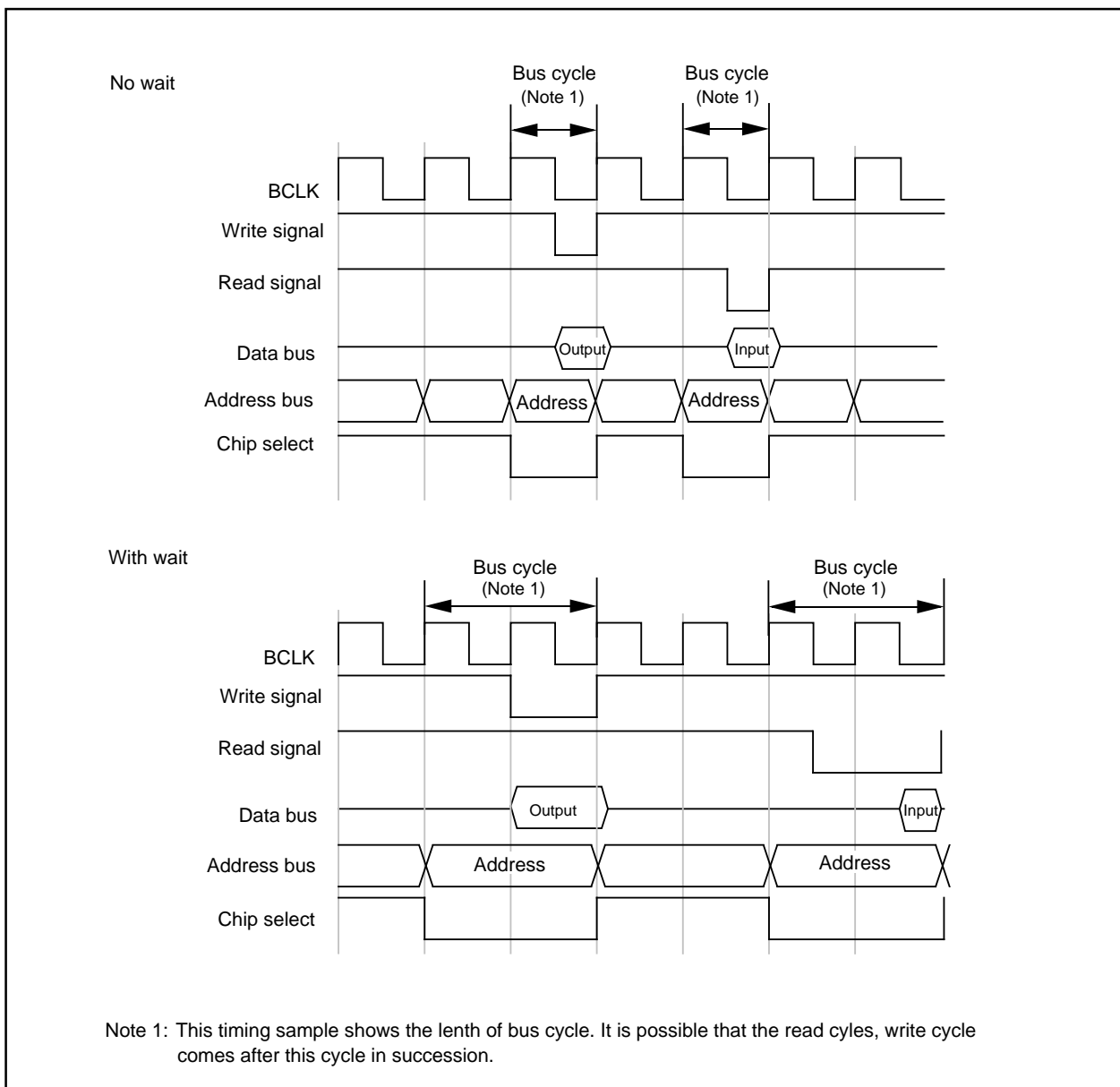

**Fig.EF-1 Typical bus timings using software wait**

### Clock Generating Circuit

The clock generating circuit contains two oscillator circuits that supply the operating clock sources to the CPU and internal peripheral units.

**Table.WA-1 Main clock and sub clock generating circuits**

	Main clock generating circuit	Sub clock generating circuit
Use of clock	<ul style="list-style-type: none"> <li>• CPU's operating clock source</li> <li>• Internal peripheral units' operating clock source</li> </ul>	<ul style="list-style-type: none"> <li>• CPU's operating clock source</li> <li>• Timer A/B's count clock source</li> </ul>
Usable oscillator	Ceramic or crystal oscillator	Crystal oscillator
Pins to connect oscillator	XIN, XOUT	XCIN, XCOU
Oscillation stop/restart function	Available	Available
Oscillator status immediately after reset	Oscillating	Stopped
Other	Externally derived clock can be input	

### Example of oscillator circuit

Fig.WA-1 shows some examples of the main clock circuit, one using an oscillator connected to the circuit, and the other one using an externally derived clock for input. Figure WA-2 shows some examples of sub clock circuits, one using an oscillator connected to the circuit, and the other one using an externally derived clock for input. Circuit constants in Fig.WA-1 and WA-2 vary with each oscillator used. Use the values recommended by the manufacturer of your oscillator.

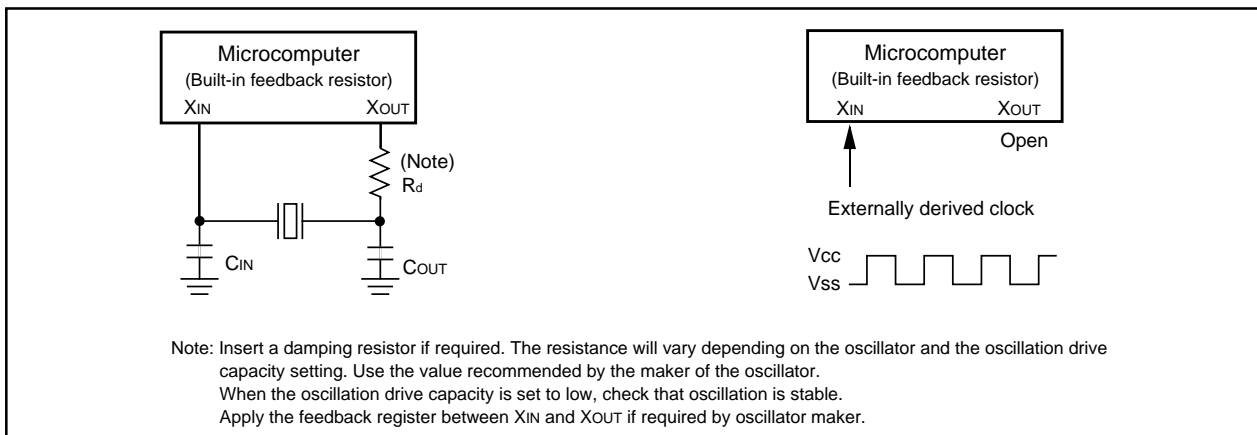

**Fig.WA-1 Examples of main clock**

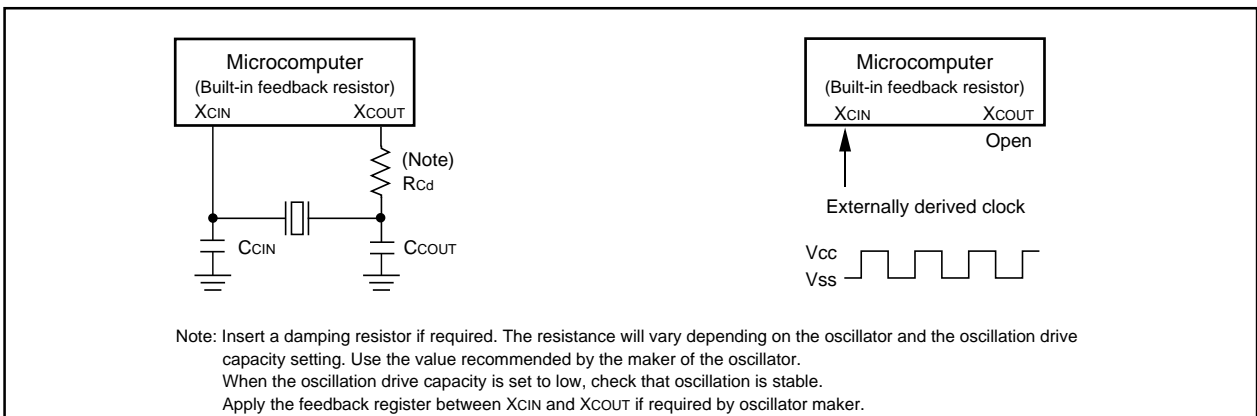

**Fig.WA-2 Examples of sub clock**

**Clock Control**

Fig.WA-3 shows the block diagram of the clock generating circuit.

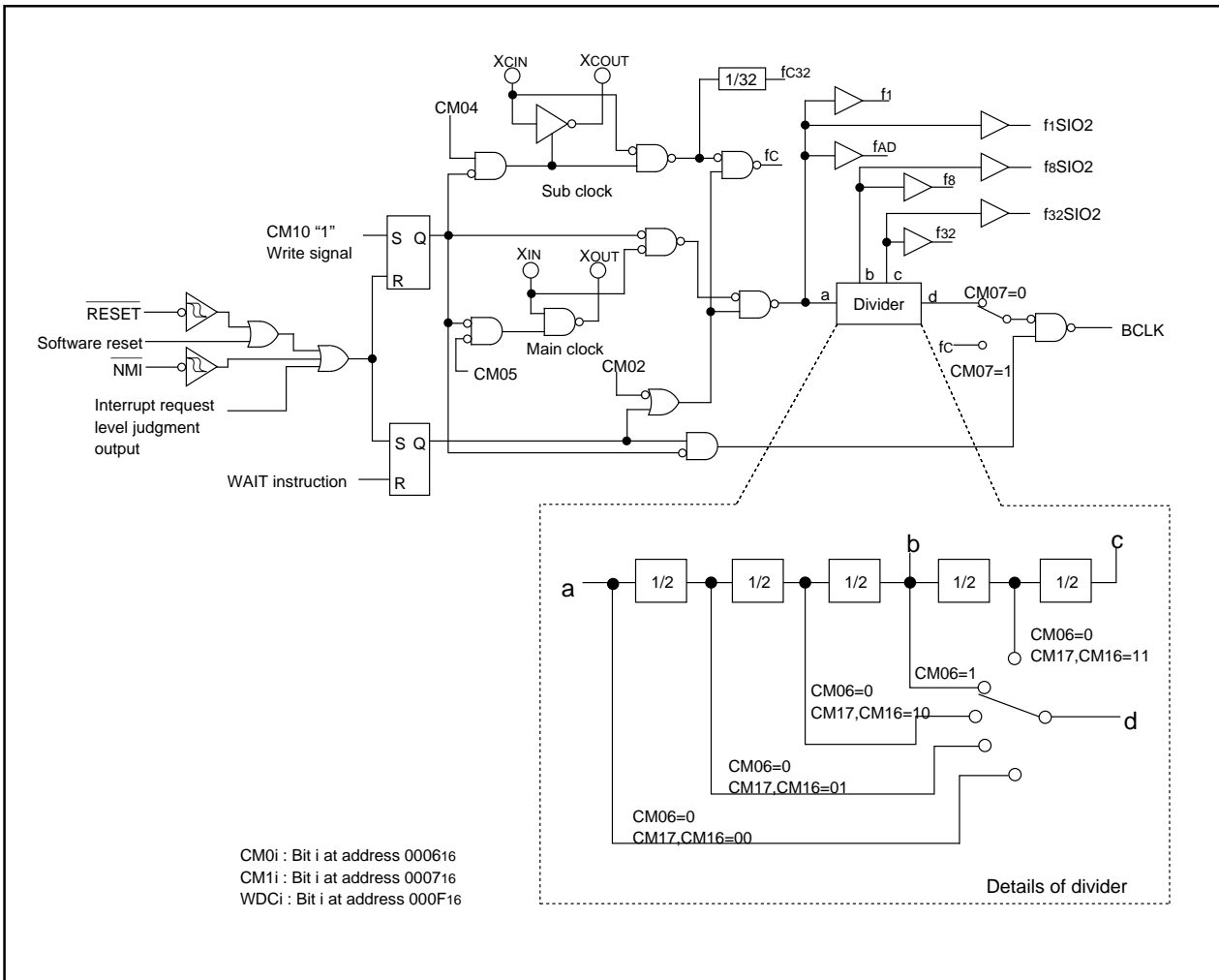

**Fig.WA-3 Clock generating circuit**

The following paragraphs describes the clocks generated by the clock generating circuit.

### (1) Main clock

The main clock is generated by the main clock oscillation circuit. After a reset, the clock is divided by 8 to the BCLK. The clock can be stopped using the main clock stop bit (bit 5 at address 0006<sub>16</sub>). After switching the CPU operation clock to sub clock stopping the clock reduces the power dissipation.

After the oscillation of the main clock oscillation circuit has stabilized, the drive capacity of the main clock oscillation circuit can be reduced using the XIN-XOUT drive capacity select bit (bit 5 at address 0007<sub>16</sub>). Reducing the drive capacity of the main clock oscillation circuit reduces the power dissipation. This bit defaults to "1" when shifting from high speed mode or mid-speed mode to stop mode and after a reset.

### (2) Sub clock

The sub clock is generated by the sub clock oscillation circuit. No sub clock is generated after a reset. After oscillation is started using the port Xc select bit (bit 4 at address 0006<sub>16</sub>), the sub clock can be selected as the BCLK by using the system clock select bit (bit 7 at address 0006<sub>16</sub>). However, be sure that the sub clock oscillation has fully stabilized before switching.

After the oscillation of the sub clock oscillation circuit has stabilized, the drive capacity of the sub clock oscillation circuit can be reduced using the XCIN-XCOUT drive capacity select bit (bit 3 at address 0006<sub>16</sub>). Reducing the drive capacity of the sub clock oscillation circuit reduces the power dissipation. This bit changes to "1" when shifting to stop mode and at a reset.

### (3) BCLK

The BCLK is the clock that drives the CPU, and is either the main clock or fc or is derived by dividing the main clock by 2, 4, 8, or 16. The BCLK is derived by dividing the main clock by 8 after a reset.

When shifting from high speed mode or mid-speed mode to stop mode, the main clock division select bit (bit 6 at 0006<sub>16</sub>) is set to "1". The bit maintains in low speed mode and low power save mode.

### (4) Peripheral function clock

f1, f8, f32, f1SIO2, f8SIO2, f32SIO2, fAD

The clock for the peripheral devices is derived from the main clock or by dividing it by 8 or 32. The peripheral function clock is stopped by stopping the main clock or by setting the WAIT peripheral function clock stop bit (bit 2 at 0006<sub>16</sub>) to "1" and then executing a WAIT instruction.

### (5) fc32

This clock is derived by dividing the sub clock by 32. It is used for the timer A and timer B counts.

### (6) fc

This clock has the same frequency as the sub clock. It is used for the BCLK and for the watchdog timer.



Fig.WA-4 shows the system clock control registers 0 and 1.

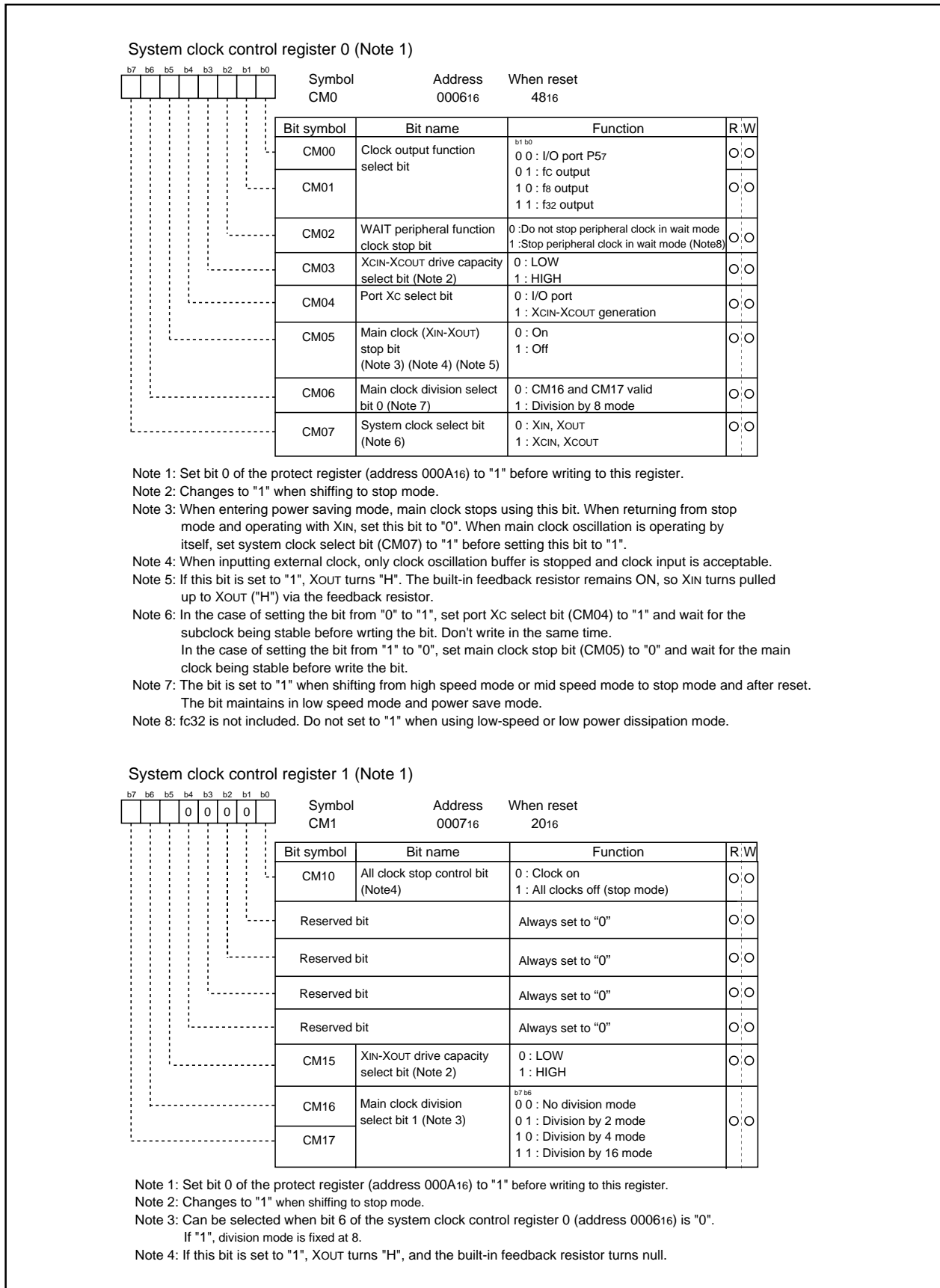

Fig.WA-4 System clock control registers 0 and 1

## Clock Output

In single-chip mode, the clock output function select bits (bits 0 and 1 at address 0006<sub>16</sub>) enable f<sub>8</sub>, f<sub>32</sub>, or f<sub>c</sub> to be output from the P57/CLKOUT pin. When the WAIT peripheral function clock stop bit (bit 2 at address 0006<sub>16</sub>) is set to "1", the output of f<sub>8</sub> and f<sub>32</sub> stops when a WAIT instruction is executed.

## Stop Mode

Writing "1" to the all-clock stop control bit (bit 0 at address 0007<sub>16</sub>) stops all oscillation and the microcomputer enters stop mode. In stop mode, the content of the internal RAM is retained provided that VCC remains above 2V.

The oscillation, BCLK, f<sub>1</sub> to f<sub>32</sub>, f<sub>1</sub>SIO<sub>2</sub> to f<sub>32</sub>SIO<sub>2</sub>, f<sub>c</sub>, f<sub>c</sub>32, and f<sub>AD</sub> stop in stop mode, peripheral functions such as the A-D converter and watchdog timer do not function. However, timer A and timer B operate provided that the event counter mode is set to an external pulse, and UART<sub>i</sub> (i = 0 to 2), SIO<sub>3,4</sub> functions provided an external clock is selected. Table.WA-2 shows the status of the ports in stop mode.

Stop mode is cancelled by a hardware reset or interrupt. If an interrupt is to be used to cancel stop mode, that interrupt must first have been enabled. After the restoration by interrupt, the corresponding interrupt routine will be processed. When shifting from high speed mode or mid-speed mode to stop mode, the main clock division select bit 0 (bit 6 at 0006<sub>16</sub>) is set to "1".

**Table.WA-2 Port status during stop mode**

Pin		Single-chip mode
Port		Retains status before stop mode
CLKOUT	When f <sub>c</sub> selected	"H"
	When f <sub>8</sub> , f <sub>32</sub> selected	Retains status before stop mode

## Wait Mode

When a WAIT instruction is executed, the BCLK stops and the microcomputer enters the wait mode. In this mode, oscillation continues but the BCLK and watchdog timer stop. Writing "1" to the WAIT peripheral function clock stop bit and executing a WAIT instruction stops the clock being supplied to the internal peripheral functions, allowing power dissipation to be reduced. However, because the peripheral function clock (fc32) that is generated by sub clock does not stop, there is no reducing of power dissipation. Do not set the bit to "1" then enter wait mode in low speed mode and low power dissipation mode. Table.WA-3 shows the status of the ports in wait mode.

Wait mode is cancelled by a hardware reset or interrupt. If an interrupt is used to cancel wait mode, the microcomputer restarts from interrupt routine using as BCLK, the clock that had been selected when the WAIT instruction was executed.

**Table.WA-3 Port status during wait mode**

Pin		Single-chip mode
CLKOUT	When fc selected	Does not stop
	When f8, f32 selected	Does not stop when the WAIT peripheral function clock stop bit is "0". When the WAIT peripheral function clock stop bit is "1", the status immediately prior to entering wait mode is maintained.
Port		maintained the status immediately prior to enterig wait mode

## Status Transition Of BCLK

Power dissipation can be reduced and low-voltage operation achieved by changing the count source for BCLK. Table.WA-4 shows the operating modes corresponding to the settings of system clock control registers 0 and 1.

After a reset, operation defaults to division by 8 mode. When shifting from high speed mode or mid-speed mode to stop mode, and after a reset main clock division select bit 0 (bit 6 at address 000616) is set to "1". It is maintained in low speed mode and low power dissipation mode.

### (1) Division by 2 mode

The main clock is divided by 2 to obtain the BCLK.

### (2) Division by 4 mode

The main clock is divided by 4 to obtain the BCLK.

### (3) Division by 8 mode

The main clock is divided by 8 to obtain the BCLK. After reset, it works in this mode. Note that oscillation of the main clock must have stabilized before transferring from this mode to No-division, Division by 2 and Division by 4 mode. Oscillation of the sub clock must have stabilized before transferring this mode to Low-speed mode and Low power dissipation mode.

### (4) Division by 16 mode

The main clock is divided by 16 to obtain the BCLK.

### (5) No-division mode

The main clock is used as the BCLK.

### (6) Low-speed mode

fc is used as the BCLK. Note that oscillation of both the main and sub clocks must have stabilized before transferring from this mode to another or vice versa. At least 2 to 3 seconds are required after the sub clock starts. Therefore, the program must be written to wait until this clock has stabilized immediately after powering up and after stop mode is cancelled.

### (7) Low power dissipation mode

fc is the BCLK and the main clock is stopped.

## Precaution

In the case of switching the BCLK count source from XIN to XCIN, or from XCIN to XIN, it is necessary that the destination clock count source be stable. The transition should be waited by software after the oscillation being stable.

**Table.WA-4 Operating modes dictated by settings of system clock control registers 0 and 1**

CM17	CM16	CM07	CM06	CM05	CM04	Operating mode of BCLK
0	1	0	0	0	Invalid	Division by 2 mode
1	0	0	0	0	Invalid	Division by 4 mode
Invalid	Invalid	0	1	0	Invalid	Division by 8 mode
1	1	0	0	0	Invalid	Division by 16 mode
0	0	0	0	0	Invalid	No-division mode
Invalid	Invalid	1	Invalid	0	1	Low-speed mode
Invalid	Invalid	1	Invalid	1	1	Low power dissipation mode

## Power control

The following is a description of the power control modes:

### Modes

Power control is available in three modes.

#### (1) Normal operation mode

- High-speed mode

Divide-by-1 frequency of the main clock becomes the BCLK. The CPU operates with the internal clock selected. Each peripheral function operates according to its assigned clock.

- Medium-speed mode

Divide-by-2, divide-by-4, divide-by-8, or divide-by-16 frequency of the main clock becomes the BCLK. The CPU operates according to the internal clock selected. Each peripheral function operates according to its assigned clock.

- Low-speed mode

fc becomes the BCLK. The CPU operates according to the fc clock. The fc clock is supplied by the sub clock. Each peripheral function operates according to its assigned clock.

- Low power consumption mode

The main clock operating in low-speed mode is stopped. The CPU operates according to the fc clock. The fc clock is supplied by the sub clock. The only peripheral functions that operate are those with the sub-clock selected as the count source.

#### (2) Wait mode

The CPU operation is stopped. The oscillators do not stop.

#### (3) Stop mode

All oscillators stop. The CPU and all built-in peripheral functions stop. This mode, among the three modes listed here, is the most effective in decreasing power consumption.

Fig.WA-5 is the state transition diagram of (1) to (3).

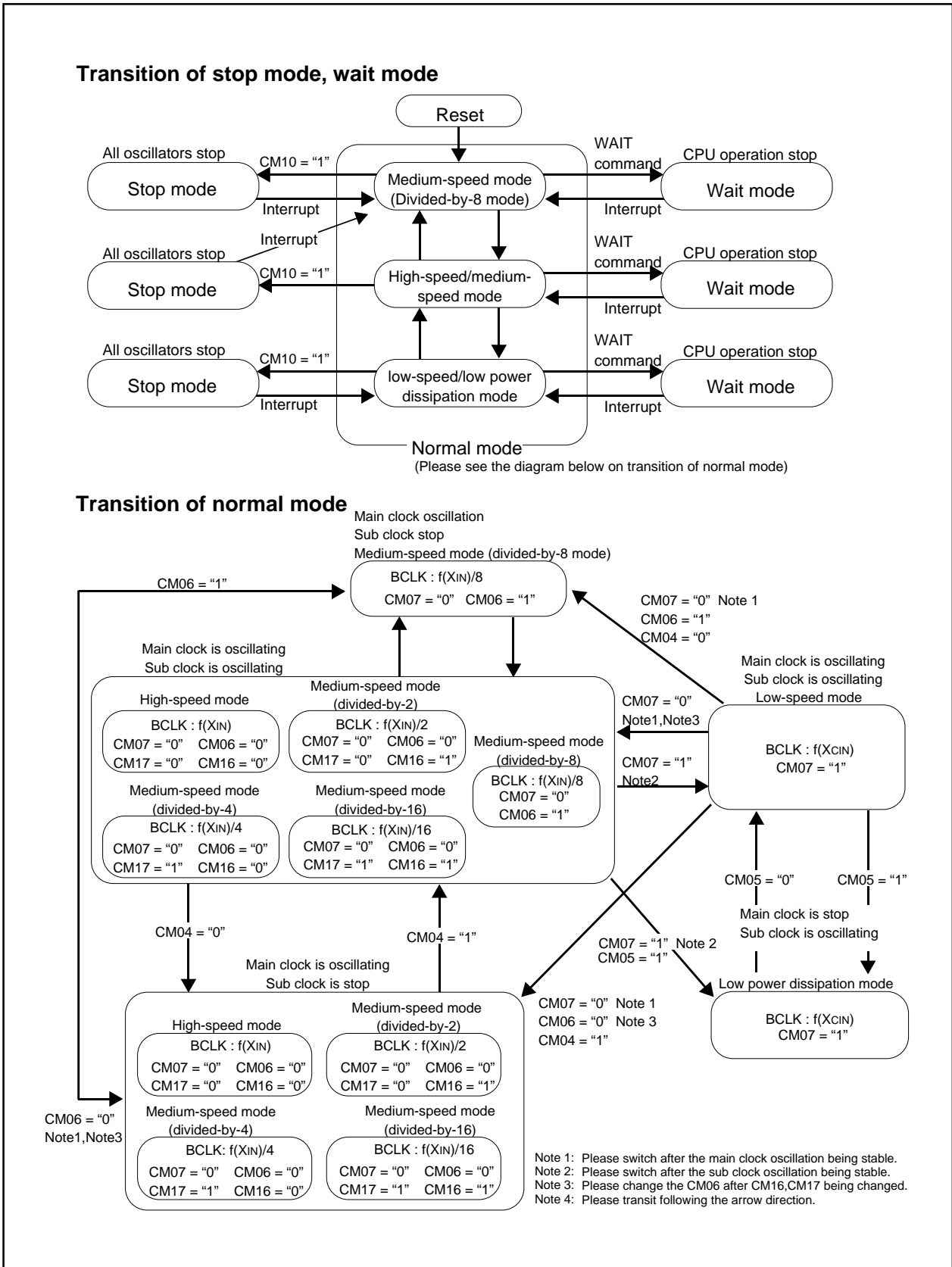

Fig.WA-5 State transition diagram of Power control mode

## Protection

The protection function is provided so that the values in important registers cannot be changed in the event that the program runs out of control. Fig.WA-6 shows the protect register. The values in the processor mode register 0 (address 0004<sub>16</sub>), processor mode register 1 (address 0005<sub>16</sub>), system clock control register 0 (address 0006<sub>16</sub>), system clock control register 1 (address 0007<sub>16</sub>), port P9 direction register (address 03F3<sub>16</sub>), SI/O3 control register (address 0362<sub>16</sub>) and SI/O4 control register (address 0366<sub>16</sub>) can only be changed when the respective bit in the protect register is set to "1". Therefore, important outputs can be allocated to port P9.

If, after "1" (write-enabled) has been written to the port P9 direction register and SI/O<sub>i</sub> control register (i=3,4) write-enable bit (bit 2 at address 000A<sub>16</sub>), a value is written to any address, the bit automatically reverts to "0" (write-inhibited). However, the system clock control registers 0 and 1 write-enable bit (bit 0 at 000A<sub>16</sub>) and processor mode register 0 and 1 write-enable bit (bit 1 at 000A<sub>16</sub>) do not automatically return to "0" after a value has been written to an address. The program must therefore be written to return these bits to "0".

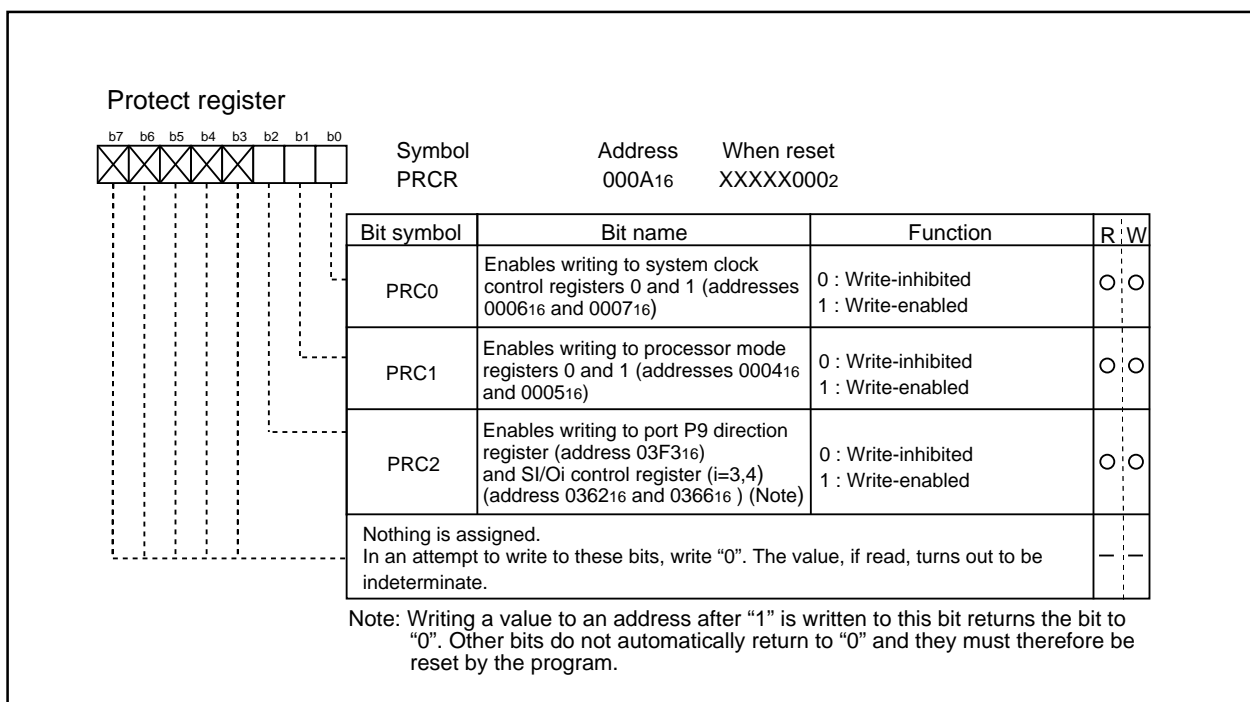

Fig.WA-6 Protect register

## Overview of Interrupt

### Type of Interrupts

Fig.DD-1 lists the types of interrupts.

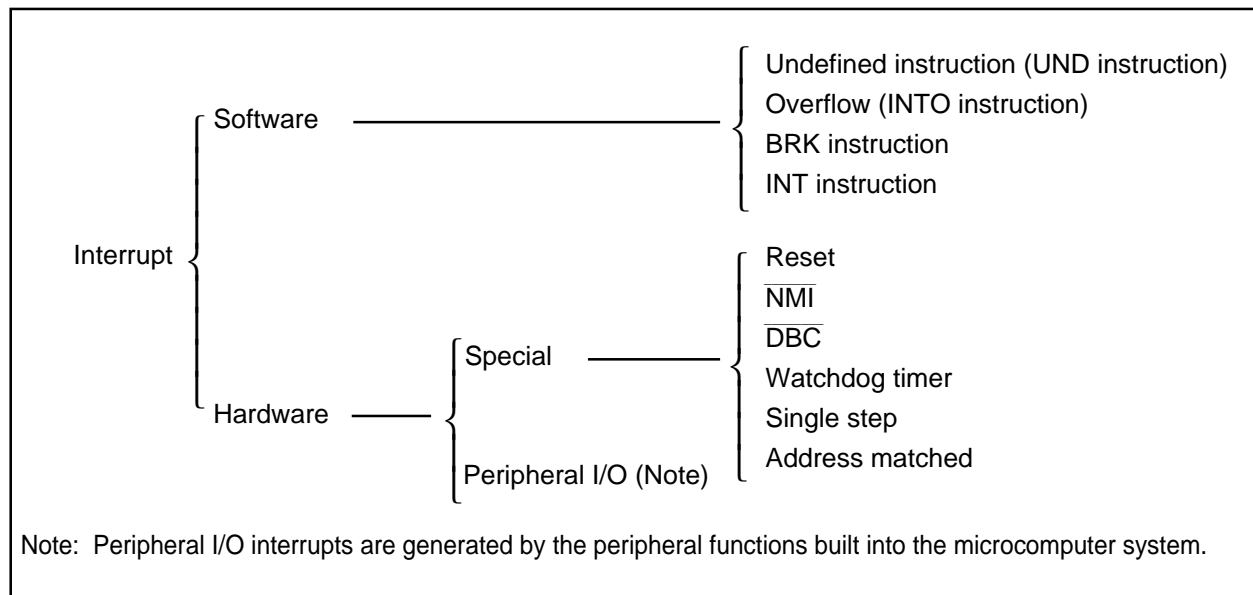

Fig.DD-1 Classification of interrupts

- Maskable interrupt : An interrupt which can be enabled (disabled) by the interrupt enable flag (I flag) or whose interrupt priority **can be changed** by priority level.
- Non-maskable interrupt : An interrupt which cannot be enabled (disabled) by the interrupt enable flag (I flag) or whose interrupt priority **cannot be changed** by priority level.



## Software Interrupts

A software interrupt occurs when executing certain instructions. Software interrupts are non-maskable interrupts.

- Undefined instruction interrupt

An undefined instruction interrupt occurs when executing the UND instruction.

- Overflow interrupt

An overflow interrupt occurs when executing the INTO instruction with the overflow flag (O flag) set to "1".

The following are instructions whose O flag changes by arithmetic:

ABS, ADC, ADCF, ADD, CMP, DIV, DIVU, DIVX, NEG, RMPA, SBB, SHA, SUB

- BRK interrupt

A BRK interrupt occurs when executing the BRK instruction.

- INT interrupt

An INT interrupt occurs when assigning one of software interrupt numbers 0 through 63 and executing the INT instruction. Software interrupt numbers 0 through 31 are assigned to peripheral I/O interrupts, so executing the INT instruction allows executing the same interrupt routine that a peripheral I/O interrupt does. The stack pointer (SP) used for the INT interrupt is dependent on which software interrupt number is involved.

So far as software interrupt numbers 0 through 31 are concerned, the microcomputer saves the stack pointer assignment flag (U flag) when it accepts an interrupt request. If change the U flag to "0" and select the interrupt stack pointer (ISP), and then execute an interrupt sequence. When returning from the interrupt routine, the U flag is returned to the state it was before the acceptance of interrupt request. So far as software numbers 32 through 63 are concerned, the stack pointer does not make a shift.

## Hardware Interrupts

Hardware interrupts are classified into two types — special interrupts and peripheral I/O interrupts.

### (1) Special interrupts

Special interrupts are non-maskable interrupts.

- Reset

Reset occurs if an “L” is input to the  $\overline{\text{RESET}}$  pin.

- $\overline{\text{NMI}}$  interrupt

An  $\overline{\text{NMI}}$  interrupt occurs if an “L” is input to the  $\overline{\text{NMI}}$  pin.

- $\overline{\text{DBC}}$  interrupt

This interrupt is exclusively for the debugger, do not use it in other circumstances.

- Watchdog timer interrupt

Generated by the watchdog timer.

- Single-step interrupt

This interrupt is exclusively for the debugger, do not use it in other circumstances. With the debug flag (D flag) set to “1”, a single-step interrupt occurs after one instruction is executed.

- Address match interrupt

An address match interrupt occurs immediately before the instruction held in the address indicated by the address match interrupt register is executed with the address match interrupt enable bit set to “1”.

If an address other than the first address of the instruction in the address match interrupt register is set, no address match interrupt occurs.

### (2) Peripheral I/O interrupts

A peripheral I/O interrupt is generated by one of built-in peripheral functions. Built-in peripheral functions are dependent on classes of products, so the interrupt factors are also dependent on classes of products. The interrupt vector table is the same as the one for software interrupt numbers 0 through 31 the INT instruction uses. Peripheral I/O interrupts are maskable interrupts.

#### 1) Bus collision detection interrupt

This is an interrupt that the serial I/O bus collision detection generates.

#### 2) DMA0 interrupt, DMA1 interrupt

These are interrupts that DMA generates.

#### 3) Key-input interrupt 0 / Key-input interrupt 1

A key-input interrupt occurs if an “L” is input to the  $\overline{\text{KI}}$  pin.

#### 4) A-D conversion interrupt

This is an interrupt that the A-D converter generates.

#### 5) UART0, UART1, UART2/NACK, SI/O3 and SI/O4 transmission interrupt

These are interrupts that the serial I/O transmission generates.

#### 6) UART0, UART1, UART2/ACK, SI/O3 and SI/O4 reception interrupt

These are interrupts that the serial I/O reception generates.

#### 7) Timer A0 interrupt through timer A4 interrupt

These are interrupts that timer A generates

#### 8) Timer B0 interrupt through timer B5 interrupt

These are interrupts that timer B generates.

#### 9) $\overline{\text{INT0}}$ interrupt through $\overline{\text{INT11}}$ interrupt

An  $\overline{\text{INT}}$  interrupt occurs if either a rising edge or a falling edge or both edges are input to the  $\overline{\text{INT}}$  pin.

10)IBF0 to IBF3 interrupt

These are interrupts that host bus interface generates.

11)I<sup>2</sup>C0,I<sup>2</sup>C1,SCL0,SDA0,SCL1,SDA1 interrupt

These are interrupts that I<sup>2</sup>C bus interface generates.

12)PS20 to PS22 interrupt

These are interrupt that PS2 interface generates.

## Interrupts and Interrupt Vector Tables

If an interrupt request is accepted, a program branches to the interrupt routine set in the interrupt vector table. Set the first address of the interrupt routine in each vector table. Fig.DD-2 shows the format for specifying the address.

Two types of interrupt vector tables are available — fixed vector table in which addresses are fixed and variable vector table in which addresses can be varied by the setting.

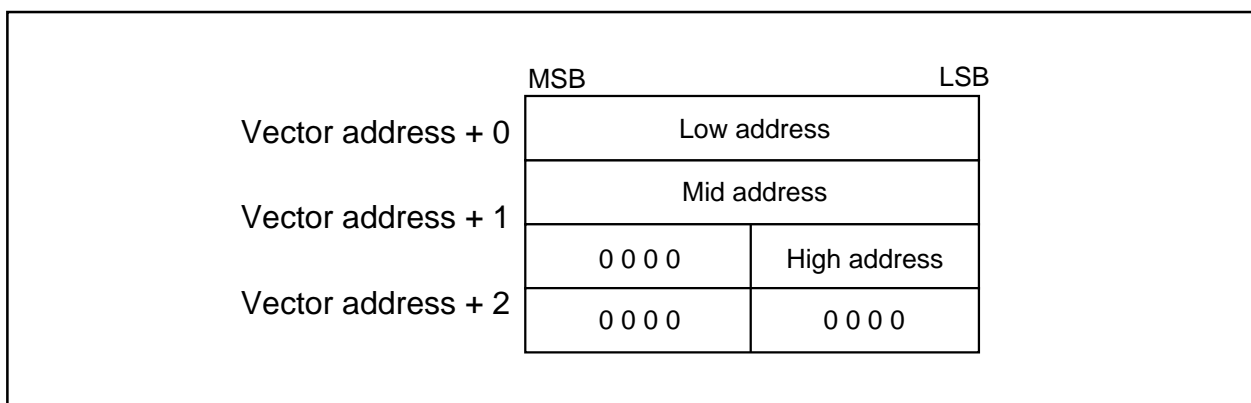

**Fig.DD-2 Format for specifying interrupt vector addresses**

- Fixed vector tables

The fixed vector table is a table in which addresses are fixed. The vector tables are located in an area extending from FFFDC<sub>16</sub> to FFFFF<sub>16</sub>. One vector table comprises four bytes. Set the first address of interrupt routine in each vector table. Table.DD-1 shows the interrupts assigned to the fixed vector tables and addresses of vector tables.

**Table.DD-1 Interrupts assigned to the fixed vector tables and addresses of vector tables**

Interrupt source	Vector table addresses Address (L) to address (H)	Remarks
Undefined instruction	FFFD <sub>16</sub> to FFFD <sub>16</sub>	Interrupt on UND instruction
Overflow	FFFE <sub>0</sub> <sub>16</sub> to FFFE <sub>3</sub> <sub>16</sub>	Interrupt on INTO instruction
BRK instruction	FFFE <sub>4</sub> <sub>16</sub> to FFFE <sub>7</sub> <sub>16</sub>	If the vector contains FF <sub>16</sub> , program execution starts from the address shown by the vector in the variable vector table
Address match	FFFE <sub>8</sub> <sub>16</sub> to FFFE <sub>B</sub> <sub>16</sub>	There is an address-matching interrupt enable bit
Single step (Note)	FFFE <sub>C</sub> <sub>16</sub> to FFFE <sub>F</sub> <sub>16</sub>	Do not use
Watchdog timer	FFFF <sub>0</sub> <sub>16</sub> to FFFF <sub>3</sub> <sub>16</sub>	
DBC (Note)	FFFF <sub>4</sub> <sub>16</sub> to FFFF <sub>7</sub> <sub>16</sub>	Do not use
NMI	FFFF <sub>8</sub> <sub>16</sub> to FFFF <sub>B</sub> <sub>16</sub>	External interrupt by input to NMI pin
Reset	FFFF <sub>C</sub> <sub>16</sub> to FFFF <sub>F</sub> <sub>16</sub>	

Note: Interrupts used for debugging purposes only.

- Variable vector tables

The addresses in the variable vector table can be modified, according to the user's settings. The start address of vector table is set to the interrupt table register (INTB). The 256-byte area subsequent that the start address is indicated by the INTB becomes the area for the variable vector tables. One vector table comprises 4 bytes. Set the first address of the interrupt routine in each vector table. Table.DD-2 shows the interrupts assigned to the variable vector tables and addresses of vector tables.

Table.DD-2 Interrupts assigned to the variable vector tables and addresses of vector tables

Software interrupt number	Vector table address Address (L) to address (H)	Interrupt source	Remarks
Software interrupt number 0	+0 to +3 (Note 1)	BRK instruction	Cannot be masked by I flag
Software interrupt number 4	+16 to +19 (Note 1)	$\overline{\text{INT3}}$	
Software interrupt number 5	+20 to +23 (Note 1)	Timer B5/ $\overline{\text{INT9}}$ (Note 2)	
Software interrupt number 6	+24 to +27 (Note 1)	Timer B4	
Software interrupt number 7	+28 to +31 (Note 1)	Timer B3	
Software interrupt number 8	+32 to +35 (Note 1)	SI/O4/ $\overline{\text{INT6}}$ (Note 2)	
Software interrupt number 9	+36 to +39 (Note 1)	SI/O3/ $\overline{\text{INT5}}$ (Note 2)	
Software interrupt number 10	+40 to +43 (Note 1)	Bus collision detection/ $\overline{\text{INT4}}$ (Note 2)	
Software interrupt number 11	+44 to +47 (Note 1)	DMA0/ $\overline{\text{INT8}}$ (Note 3)	
Software interrupt number 12	+48 to +51 (Note 1)	DMA1/ $\overline{\text{INT7}}$ (Note 3)	
Software interrupt number 13	+52 to +55 (Note 1)	Key input interrupt 0	
Software interrupt number 14	+56 to +59 (Note 1)	A-D	
Software interrupt number 15	+60 to +63 (Note 1)	UART2 transmit/IBF0 (Note 2)	
Software interrupt number 16	+64 to +67 (Note 1)	UART2 receive/IBF1 (Note 2)	
Software interrupt number 17	+68 to +71 (Note 1)	UART0 transmit/I <sup>2</sup> C0 (Note 2)	
Software interrupt number 18	+72 to +75 (Note 1)	UART0 receive/SCL0,SDA0/ $\overline{\text{INT11}}$ (Note 3)	
Software interrupt number 19	+76 to +79 (Note 1)	UART1 transmit/I <sup>2</sup> C1 (Note 2)	
Software interrupt number 20	+80 to +83 (Note 1)	UART1 receive/SCL1,SDA1/ $\overline{\text{INT10}}$ (Note 3)	
Software interrupt number 21	+84 to +87 (Note 1)	Timer A0/ $\overline{\text{INT8}}$ (Note 3)	
Software interrupt number 22	+88 to +91 (Note 1)	Timer A1/ $\overline{\text{INT7}}$ (Note 3)	
Software interrupt number 23	+92 to +95 (Note 1)	Timer A2	
Software interrupt number 24	+96 to +99 (Note 1)	Timer A3/IBF2	
Software interrupt number 25	+100 to +103 (Note 1)	Timer A4/IBF3	
Software interrupt number 26	+104 to +107 (Note 1)	Timer B0/ $\overline{\text{INT11}}$ /SCL0,SDA0 (Note 3)	
Software interrupt number 27	+108 to +111 (Note 1)	Timer B1/ $\overline{\text{INT10}}$ /SCL1,SDA1 (Note 3)	
Software interrupt number 28	+112 to +115 (Note 1)	Timer B2/Key input interrupt 1 (Note 2)	
Software interrupt number 29	+116 to +119 (Note 1)	$\overline{\text{INT0}}$ /PS20 (Note 2)	
Software interrupt number 30	+120 to +123 (Note 1)	$\overline{\text{INT1}}$ /PS21 (Note 2)	
Software interrupt number 31	+124 to +127 (Note 1)	$\overline{\text{INT2}}$ /PS22 (Note 2)	
Software interrupt number 32 to Software interrupt number 63	+128 to +131 (Note 1) to +252 to +255 (Note 1)	Software interrupt	Cannot be masked by I flag

Note 1: Address relative to address in interrupt table register (INTB).

Note 2: It is selected by interrupt request cause bit.

Note 3: Depend on interrupt event selection bit setting. Please do not set same interrupt event at the same time.

### Interrupt Control

Descriptions are given here regarding how to enable or disable maskable interrupts and how to set the priority to be accepted. What is described here does not apply to non-maskable interrupts.

Enable or disable a maskable interrupt using the interrupt enable flag (I flag), interrupt priority level selection bits and processor interrupt priority level (IPL). Whether an interrupt request is present or absent is indicated by the interrupt request bit. The interrupt request bit and the interrupt priority level selection bits are located in the interrupt control register of each interrupt. The interrupt enable flag (I flag) and the IPL are located in the flag register (FLG).

Fig.DD-3 and DD-4 shows the memory map of the interrupt control registers.

The interrupt factors in the same vector share the same interrupt control register. Which factor to be used depends on interrupt factor selection bit of interrupt event selection register i(address:035F<sub>16</sub>,0356<sub>16</sub>, to 0358<sub>16</sub>, i = 0 to 3) setting. After setting the interrupt factor, the corresponding interrupt request bit must be set to "0" before changing the interrupt.

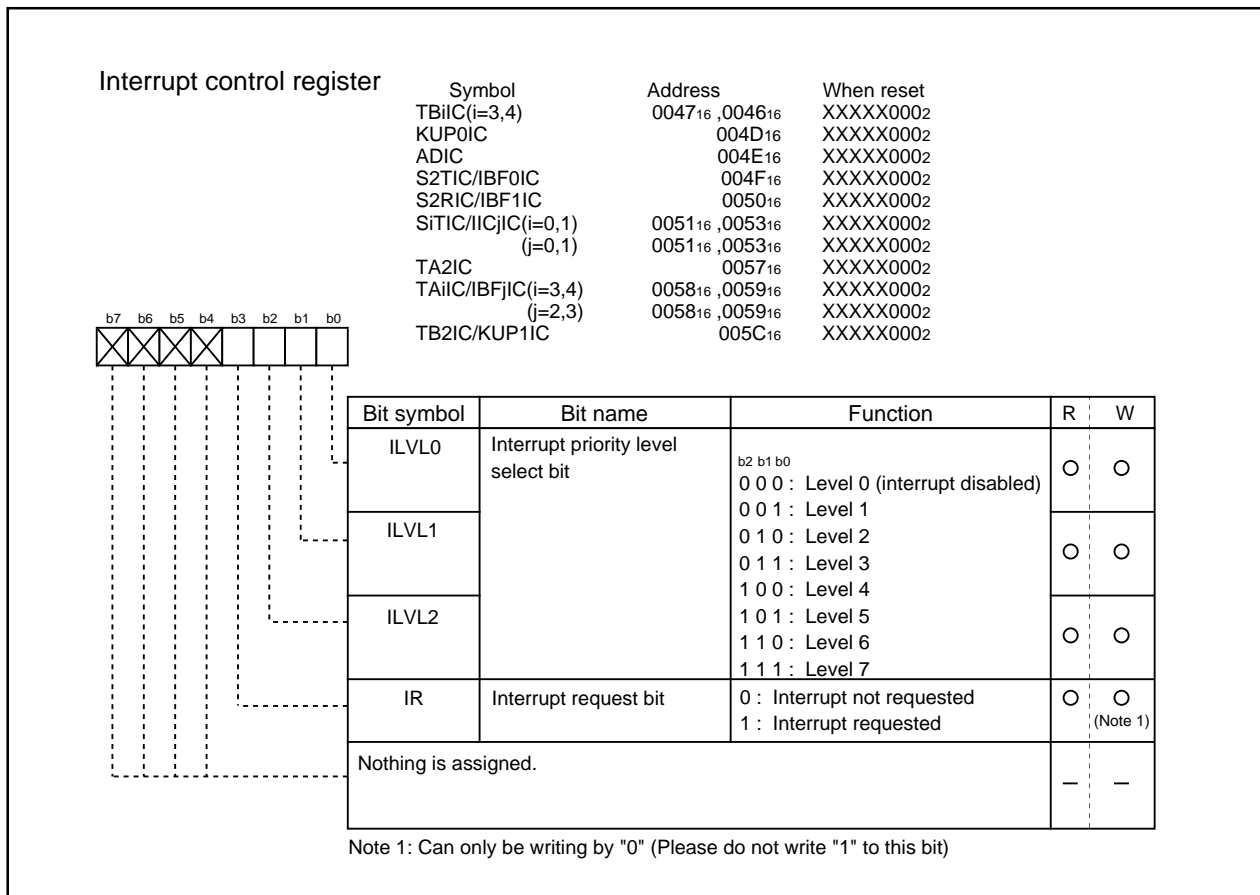
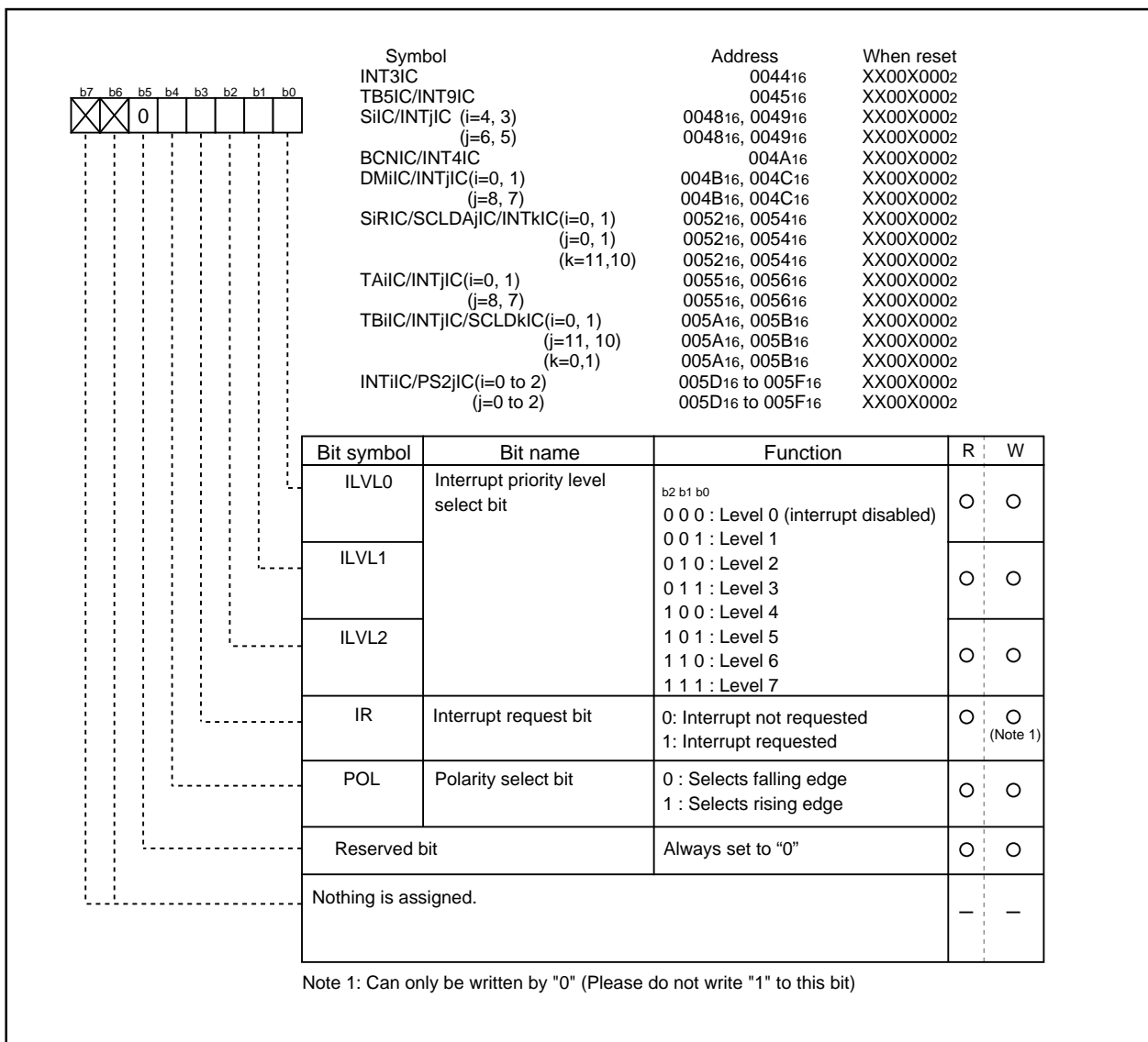

Fig.DD-3 Interrupt control registers(1)



**Fig.DD-4 Interrupt control registers (2)**



### Interrupt Enable Flag (I flag)

The interrupt enable flag (I flag) controls the enabling and disabling of maskable interrupts. Setting this flag to "1" enables all maskable interrupts; setting it to "0" disables all maskable interrupts. This flag is set to "0" after reset.

### Interrupt Request Bit

The interrupt request bit is set to "1" by hardware when an interrupt is requested. After the interrupt is accepted and jumps to the corresponding interrupt vector, the request bit is set to "0" by hardware. The interrupt request bit can also be set to "0" by software. (Do not set this bit to "1").

### Interrupt Priority Level Select Bits and Processor Interrupt Priority Level (IPL)

Set the interrupt priority level using the interrupt priority level select bits in the interrupt control register. When an interrupt request occurs, the interrupt priority level is compared with the IPL. The interrupt is enabled only when the priority level of the interrupt is higher than the IPL. Therefore, setting the interrupt priority level to "0" disables the interrupt.

Table.DD-3 shows the settings of interrupt priority levels and Table.DD-4 shows the interrupt levels enabled, according to the consist of the IPL.

The following are conditions under which an interrupt is accepted:

- interrupt enable flag (I flag) = 1
- interrupt request bit = 1
- interrupt priority level > processor interrupt priority level (IPL)

The interrupt enable flag (I flag), the interrupt request bit, the interrupt priority select bits, and the IPL are independent, and they are not affected each other.

**Table.DD-3 Settings of interrupt priority levels**

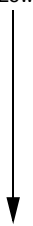
Interrupt priority level select bit	Interrupt priority level	Priority order
b2 b1 b0 0 0 0	Level 0 (interrupt disabled)	———
0 0 1	Level 1	Low  High
0 1 0	Level 2	
0 1 1	Level 3	
1 0 0	Level 4	
1 0 1	Level 5	
1 1 0	Level 6	
1 1 1	Level 7	

**Table.DD-4 Interrupt levels enabled according to the contents of the IPL**

IPL	Enabled interrupt priority levels
IPL <sub>2</sub> IPL <sub>1</sub> IPL <sub>0</sub> 0 0 0	Interrupt levels 1 and above are enabled
0 0 1	Interrupt levels 2 and above are enabled
0 1 0	Interrupt levels 3 and above are enabled
0 1 1	Interrupt levels 4 and above are enabled
1 0 0	Interrupt levels 5 and above are enabled
1 0 1	Interrupt levels 6 and above are enabled
1 1 0	Interrupt levels 7 and above are enabled
1 1 1	All maskable interrupts are disabled

## Rewrite the interrupt control register

To rewrite the interrupt control register, do so at a point that does not generate the interrupt request for that register. If there is possibility of the interrupt request occurrence, rewrite the interrupt control register after the interrupt is disabled. The program examples are described as follow:

### Example 1:

```
INT_SWITCH1:
  FCLR  I          ; Disable interrupts.
  AND.B #00h, 0055h ; Clear TA0IC int. priority level and int. request bit.
  NOP                               ; Four NOP instructions are required when using HOLD function.
  NOP
  FSET  I          ; Enable interrupts.
```

### Example 2:

```
INT_SWITCH2:
  FCLR  I          ; Disable interrupts.
  AND.B #00h, 0055h ; Clear TA0IC int. priority level and int. request bit.
  MOV.W MEM, R0    ; Dummy read.
  FSET  I          ; Enable interrupts.
```

### Example 3:

```
INT_SWITCH3:
  PUSHC FLG       ; Push Flag register onto stack
  FCLR  I          ; Disable interrupts.
  AND.B #00h, 0055h ; Clear TA0IC int. priority level and int. request bit.
  POPC  FLG       ; Enable interrupts.
```

The reason why two NOP instructions (four when using the HOLD function) or dummy read are inserted before FSET I in Examples 1 and 2 is to prevent the interrupt enable flag I from being set before the interrupt control register is rewritten due to effects of the instruction queue.

When a instruction to rewrite the interrupt control register is executed but the interrupt is disabled, the interrupt request bit is not set sometimes even if the interrupt request for that register has been generated. This will depend on the instruction. If this creates problems, use the below instructions to change the register.

Instructions : AND, OR, BCLR, BSET

## Interrupt Sequence

An interrupt sequence — what are performed over a period from the instant an interrupt is accepted to the instant the interrupt routine is executed — is described here.

If an interrupt occurs during execution of an instruction, the processor determines its priority when the execution of the instruction is completed, and transfers control to the interrupt sequence from the next cycle. If an interrupt occurs during execution of either the SMOVB, SMOVF, SSTR or RMPA instruction, the processor temporarily suspends the instruction being executed, and transfers control to the interrupt sequence.

In the interrupt sequence, the processor carries out the following in sequence given:

- (1) CPU gets the interrupt information (the interrupt number and interrupt request level) by reading address 00000<sub>16</sub>.
- (2) Saves the content of the flag register (FLG) as it was immediately before the start of interrupt sequence in the temporary register (Note) within the CPU.
- (3) Sets the interrupt enable flag (I flag), the debug flag (D flag), and the stack pointer select flag (U flag) to "0" (the U flag, however does not change if the INT instruction, in software interrupt numbers 32 through 63, is executed)
- (4) Saves the content of the temporary register (Note) within the CPU in the stack area.
- (5) Saves the content of the program counter (PC) in the stack area.
- (6) Sets the interrupt priority level of the accepted instruction in the IPL.

After the procession of interrupt sequence the processor executes instructions from the first address of the interrupt routine.

Note: This register cannot be utilized by the user.

## Interrupt Response Time

'Interrupt response time' is the period between the instant an interrupt occurs and the instant the first instruction within the interrupt routine has been executed. This time comprises the period from the occurrence of an interrupt to the completion of the instruction under execution at that moment (a) and the time required for executing the interrupt sequence (b). Fig.DD-5 shows the interrupt response time.

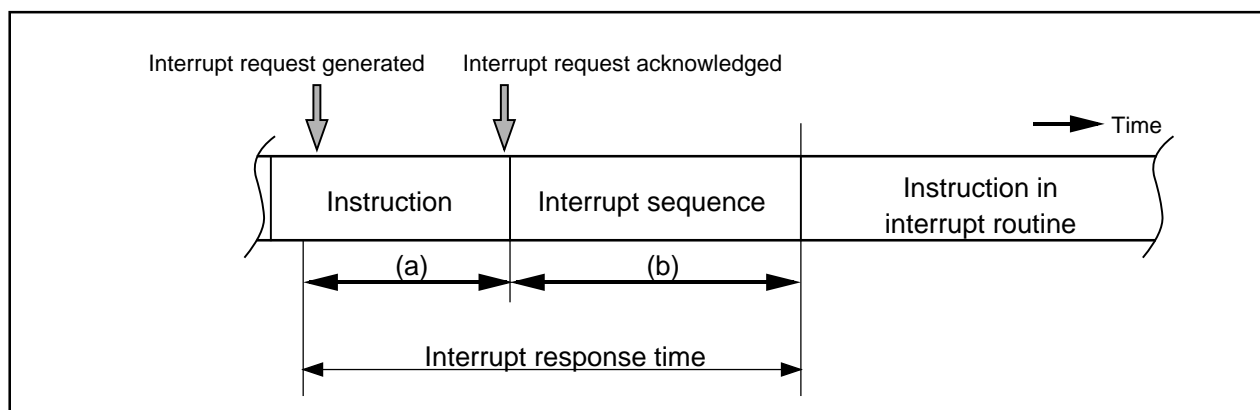

Fig.DD-5 Interrupt response time

Time (a) is dependent on the instruction under execution. 30 cycles is the maximum required for the DIVX instruction (without wait).

Time (b) is as shown in Table.DD-5

**Table.DD-5 Time required for executing the interrupt sequence**

Interrupt vector address	Stack pointer (SP) value	16-Bit bus, without wait	8-Bit bus, without wait
Even	Even	18 cycles (Note 1)	20 cycles (Note 1)
Even	Odd	19 cycles (Note 1)	20 cycles (Note 1)
Odd (Note 2)	Even	19 cycles (Note 1)	20 cycles (Note 1)
Odd (Note 2)	Odd	20 cycles (Note 1)	20 cycles (Note 1)

Note 1: Add 2 cycles in the case of a DBC interrupt; add 1 cycle in the case either of an address coincidence interrupt or of a single-step interrupt.

Note 2: Locate an interrupt vector address in an even address, if possible.

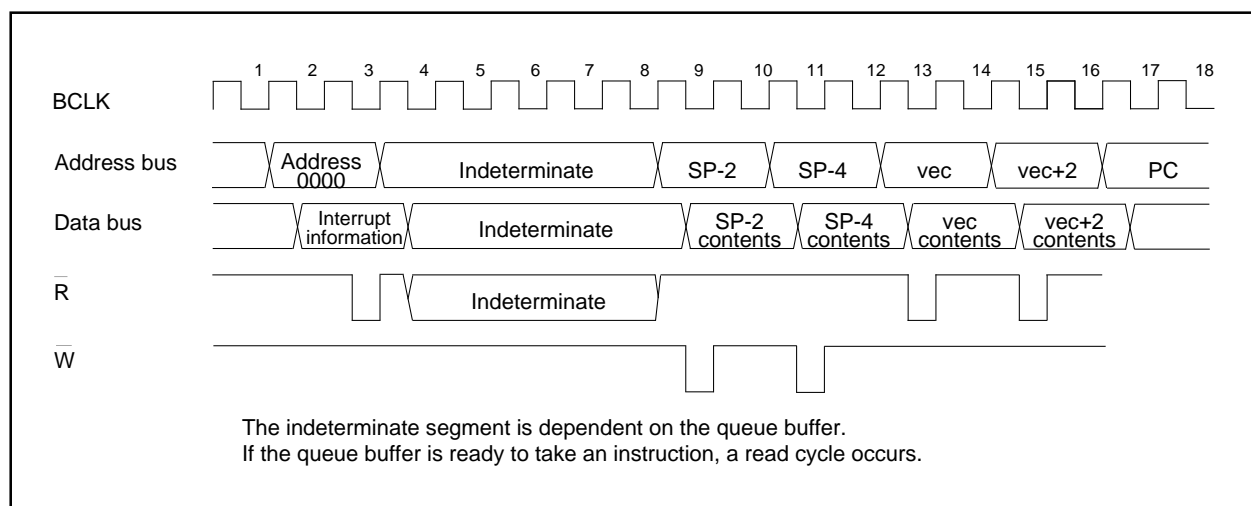

**Fig.DD-6 Time required for executing the interrupt sequence**

### Variation of IPL when Interrupt Request is Accepted

If an interrupt request is accepted, the interrupt priority level of the accepted interrupt is set in the IPL.

If an interrupt request, that does not have an interrupt priority level, is accepted, one of the values shown in Table.DD-6 is set in the IPL.

**Table.DD-6 Relationship between interrupts without interrupt priority levels and IPL**

Interrupt sources without priority levels	Value set in the IPL
Watchdog timer, NMI	7
Reset	0
Other	Not changed

### Saving Registers

In the interrupt sequence, only the contents of the flag register (FLG) and that of the program counter (PC) are saved in the stack area.

First, the processor saves the four higher-order bits of the program counter, and 4 upper-order bits and 8 lower-order bits of the FLG register, 16 bits in total, in the stack area, then saves 16 lower-order bits of the program counter. Fig.DD-7 shows the state of the stack as it was before the acceptance of the interrupt request, and the state the stack after the acceptance of the interrupt request.

Save other necessary registers at the beginning of the interrupt routine using software. Using the PUSHM instruction alone can save all the registers except the stack pointer (SP).

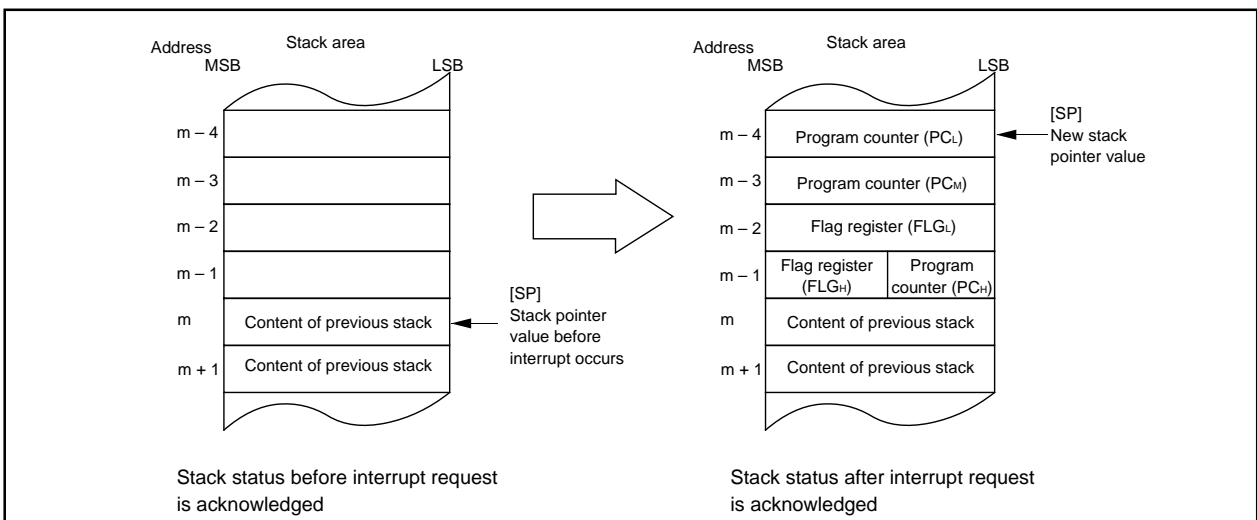

**Fig.DD-7 State of stack before and after acceptance of interrupt request**

The operation of saving registers carried out in the interrupt sequence is dependent on whether the content of the stack pointer, at the time of acceptance of an interrupt request, is even or odd. If the content of the stack pointer (Note) is even, the content of the flag register (FLG) and the content of the program counter (PC) are saved, 16 bits at a time. If odd, their contents are saved in two steps, 8 bits at a time. Fig.DD-8 shows the operation of the saving registers.

Note: Stack pointer is indicated by U flag when software number 32 - 63 INT command is executed, otherwise is indicated by ISP.

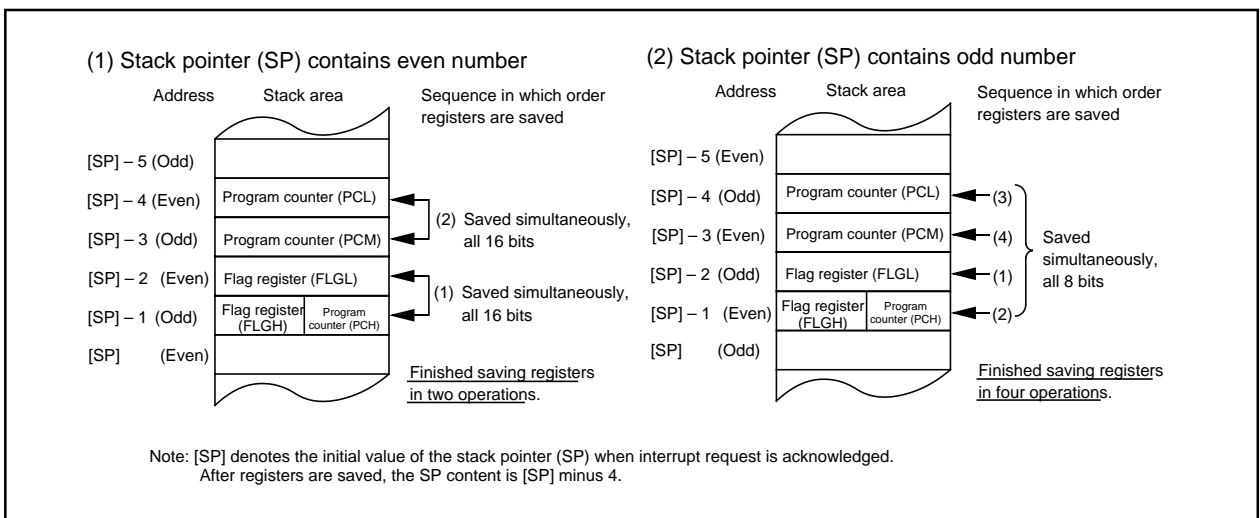

Note: [SP] denotes the initial value of the stack pointer (SP) when interrupt request is acknowledged. After registers are saved, the SP content is [SP] minus 4.

**Fig.DD-8 Operation of saving registers**

### Returning from an Interrupt Routine

Executing the REIT instruction at the end of an interrupt routine returns the contents of the flag register (FLG) as it was immediately before the start of interrupt sequence and the contents of the program counter (PC), both of which have been saved in the stack area. Then control returns to the program that was being executed before the acceptance of the interrupt request, so that the suspended process resumes.

Return the other registers saved by software within the interrupt routine using the POPM or similar instruction before executing the REIT instruction.

### Interrupt Priority

If there are two or more interrupt requests occurring at a point in time within a single sampling (checking whether interrupt requests are made), the interrupt assigned a higher priority is accepted.

Assign an arbitrary priority to maskable interrupts (peripheral I/O interrupts) using the interrupt priority level select bits. If the same interrupt priority level is assigned, however, the interrupt with higher hardware priority is accepted.

Priorities of the special interrupts, such as Reset (dealt with as an interrupt assigned the highest priority), watchdog timer interrupt, etc. are regulated by hardware.

Fig.DD-9 shows the priorities of hardware interrupts.

Software interrupts are not affected by the interrupt priority. If an instruction is executed, control branches invariably to the interrupt routine

### Interrupt priority level judgement circuit

When two or more interrupts are generated simultaneously, this circuit selects the interrupt with the highest priority level. Fig.DD-10 shows the circuit that judges the interrupt priority level..

Reset >  $\overline{\text{NMI}}$  >  $\overline{\text{DBC}}$  > Watchdog timer > Peripheral I/O > Single step > Address match

**Fig.DD-9 Hardware interrupts priorities**

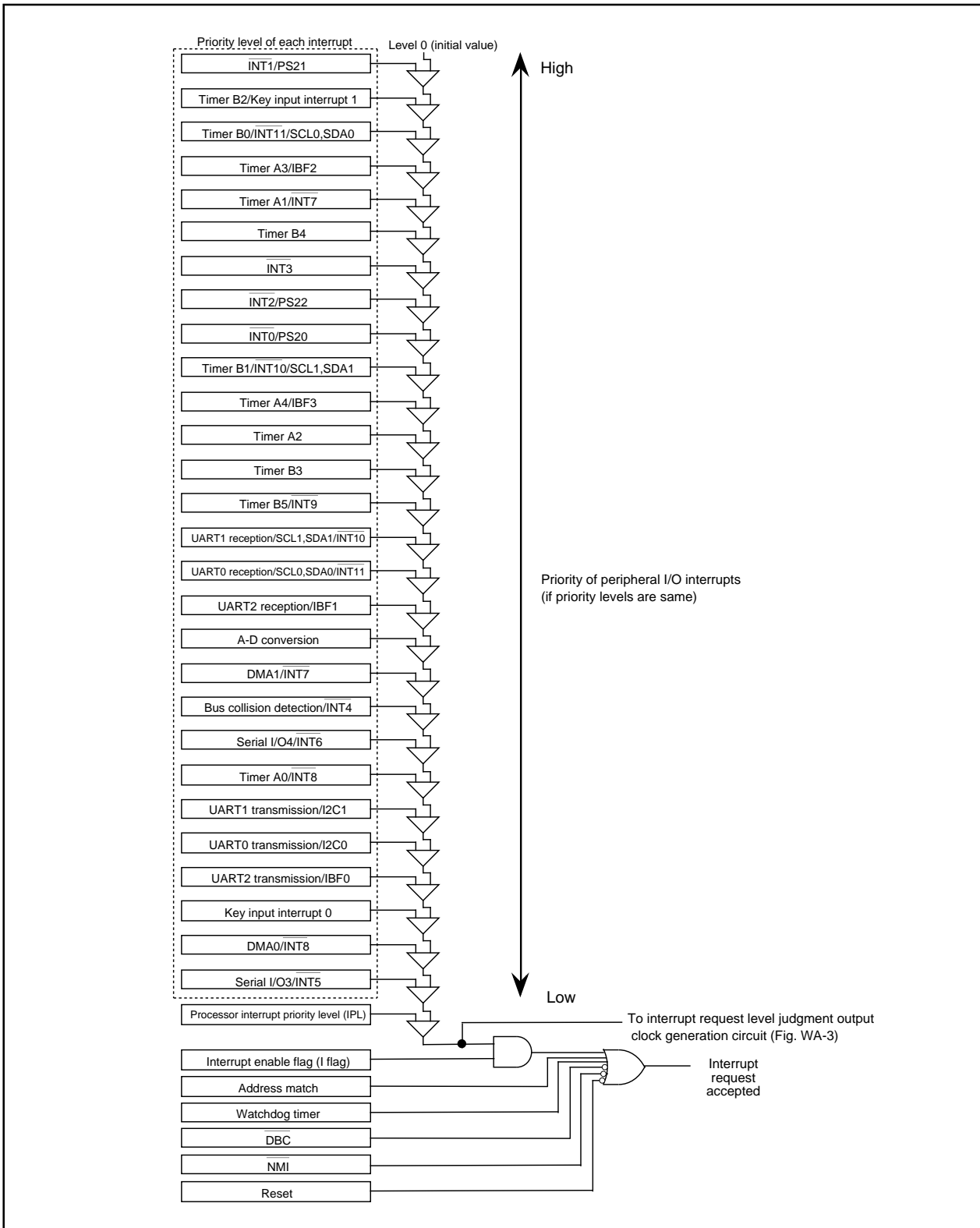

**Fig.DD-10 Interrupt priority judgement circuit**

**INT Interrupt****Factor selection**

Numbers of interrupt factors share the same interrupt registers in the addresses of 0045<sub>16</sub>, 0048<sub>16</sub> - 004C<sub>16</sub>, 004F<sub>16</sub> - 0056<sub>16</sub>, 0058<sub>16</sub> - 005F<sub>16</sub>. The setting of interrupt factor selection bits of interrupt factor selection registers 0 - 3 (addresses of 035F<sub>16</sub>, 0356<sub>16</sub> - 0358<sub>16</sub>) select the interrupt factor. After the selection of interrupt factor, the corresponding interrupt request bit must be "0" before enabling the interrupt.

Fig.DD-11 - Fig.DD-13 show the structure of interrupt factor selection register 0 - 3.

**INT Interrupt**

INT<sub>0</sub> to INT<sub>11</sub> are triggered by the edges of external inputs. The edge polarity can be selected using the polarity select bit.

INT<sub>0</sub> to INT<sub>2</sub> and INT<sub>4</sub> to INT<sub>11</sub> have polarity switching bit in the interrupt event select register. The polarity switching bit has to set to "0" when INT interrupt event is not selected.

As for external interrupt input, an interrupt can be generated both at the rising edge and at the falling edge by setting "1" in the INT<sub>i</sub> interrupt polarity switching bit of the interrupt factor selection register 0,4 (035F<sub>16</sub>, 0359<sub>16</sub>). To select both edges, set the polarity switching bit of the corresponding interrupt control register to 'falling edge' ("0").

Fig.DD-11, Fig.DD-13 show the Interrupt factor selection register 0, 4.

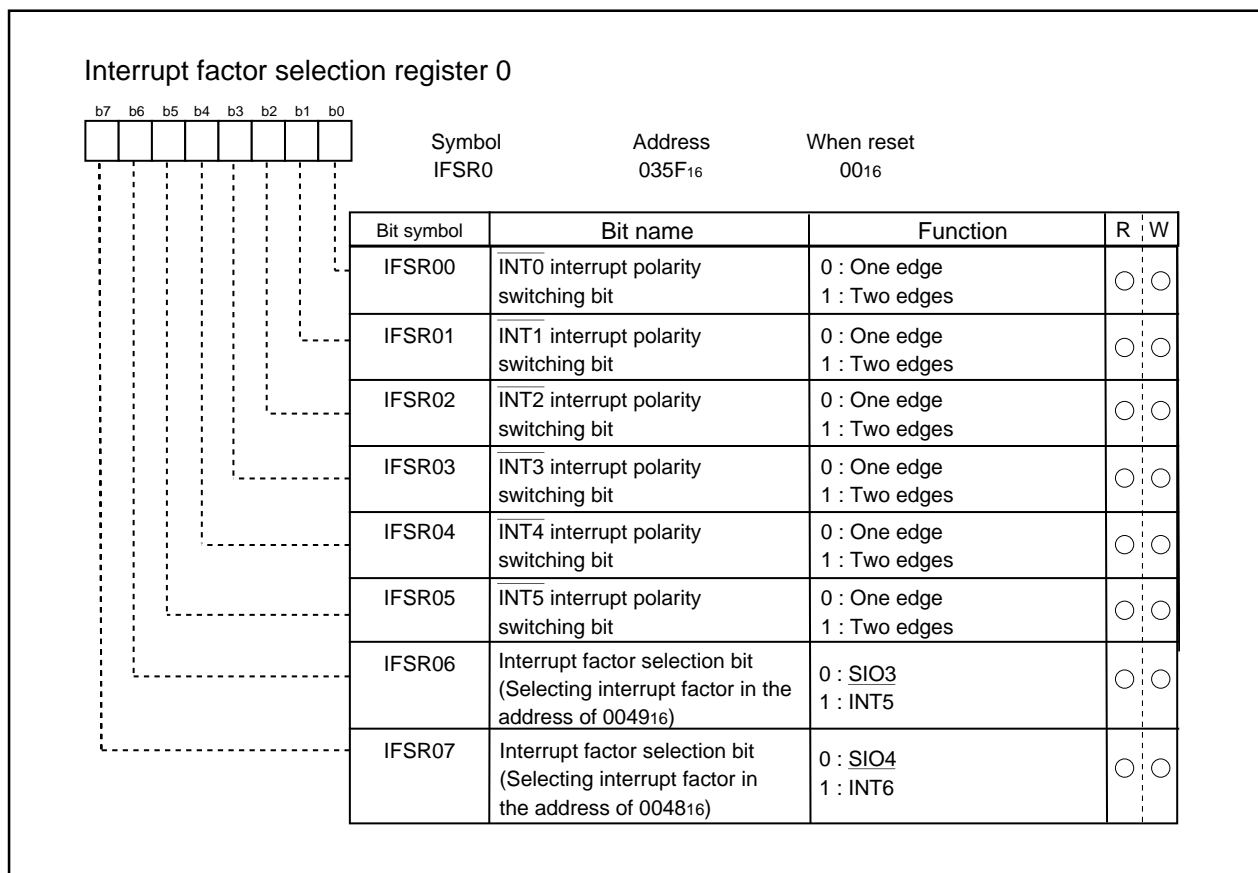

Fig.DD-11 Interrupt factor selection register(1)



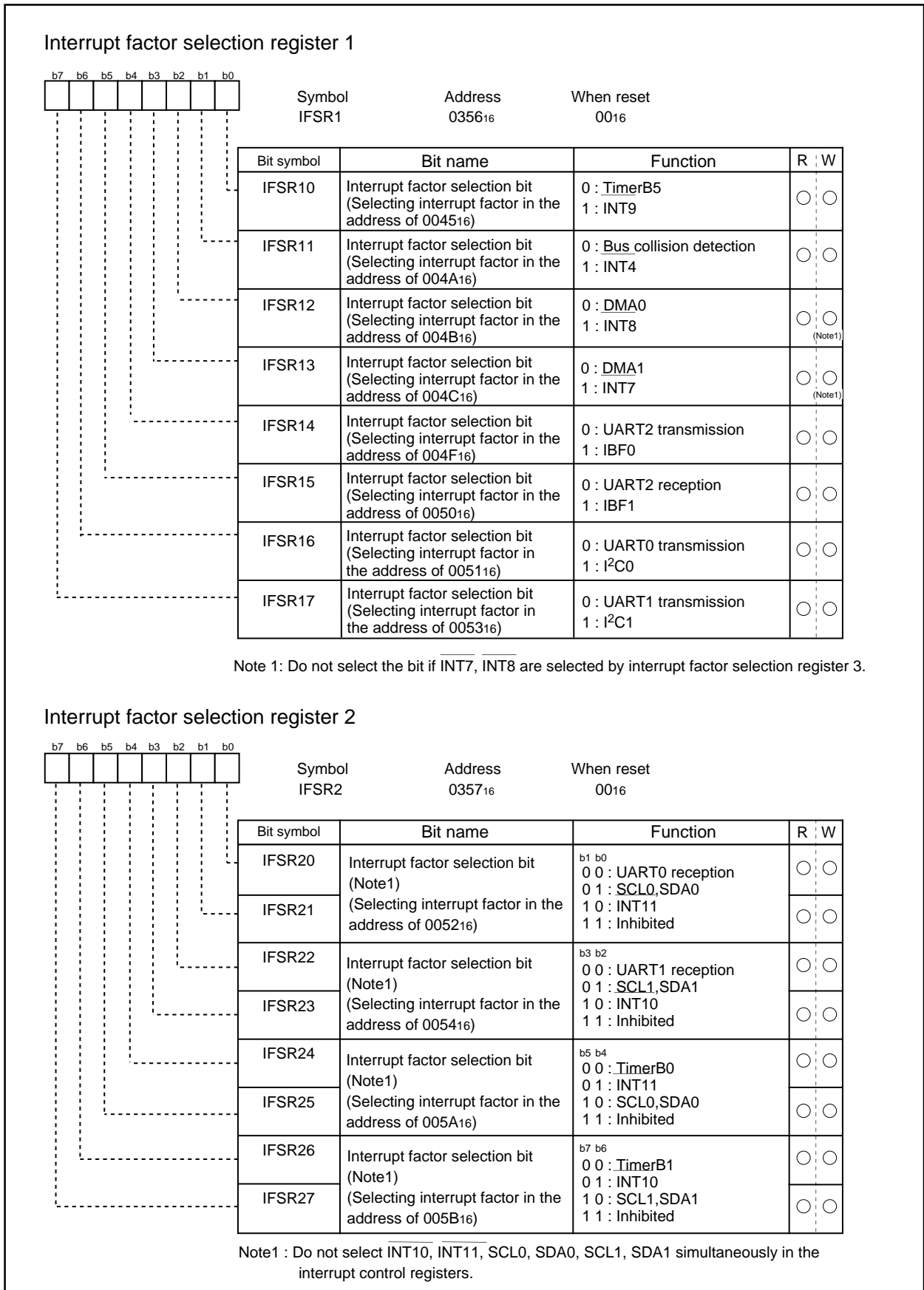

Fig.DD-12 Interrupt factor selection register(2)

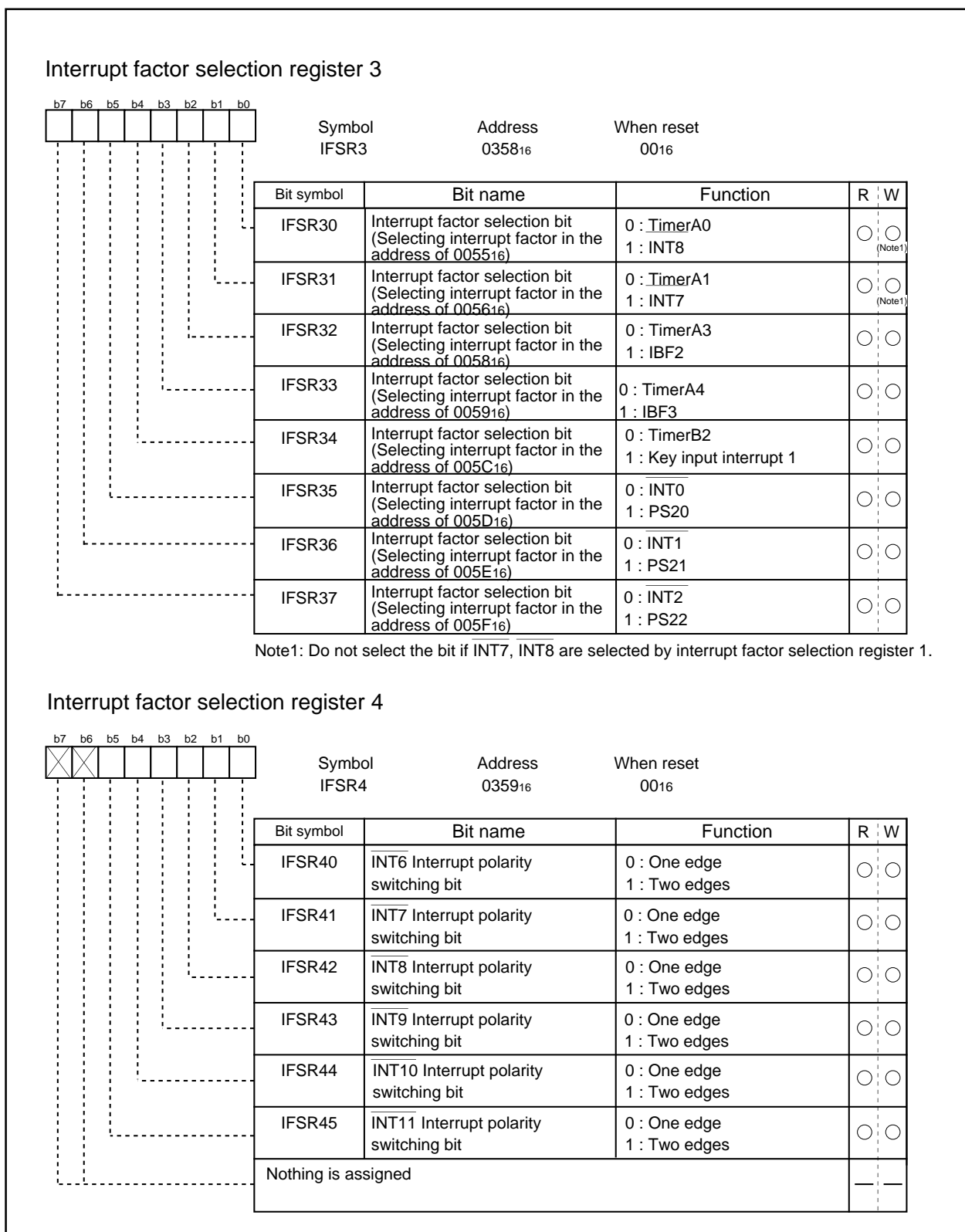

Fig.DD-13 Interrupt factor selection register(3)

## NMI Interrupt

An  $\overline{\text{NMI}}$  interrupt is generated when the input to the P85/ $\overline{\text{NMI}}$  pin changes from "H" to "L". The  $\overline{\text{NMI}}$  interrupt is a non-maskable external interrupt. The pin level can be checked in the port P85 register (bit 5 at address 03F0<sub>16</sub>).

This pin cannot be used as a normal port input.

## Key Input Interrupt 0

If the direction register of any of P50 to P57 is set for input and a falling edge is input to that port, a key input interrupt 0 is generated. A key input interrupt 0 can also be used as a key-on wakeup function for cancelling the wait mode or stop mode. Fig.DD-14 shows the block diagram of the key input interrupt 0. Note that if an "L" level is input to any pin that has not been disabled for input, inputs to the other pins are not detected as an interrupt.

## Key Input Interrupt 1

If the direction register of any of P140 to P147 is set for input and a falling edge is input to that port, a key input interrupt 1 is generated. The key input interrupt 1's function is equity to key input interrupt 0 except for the valid falling edge input will be latched. When there is a valid falling edge input in P140 to P147 the corresponding bit of P14 event register (Address : 02F6<sub>16</sub>) will be set to "1". After interrupt request is generated, the interrupt generated by "L" input can be conformed by reading the the register even the pin has been returned to "H". A dummy write to the P14 event register clears the register to "0".

The block diagram of key input interrupt 1 is shown on Fig.DD-15 and the timing diagram of key input interrupt 1 is shown on Fig.DD-16.

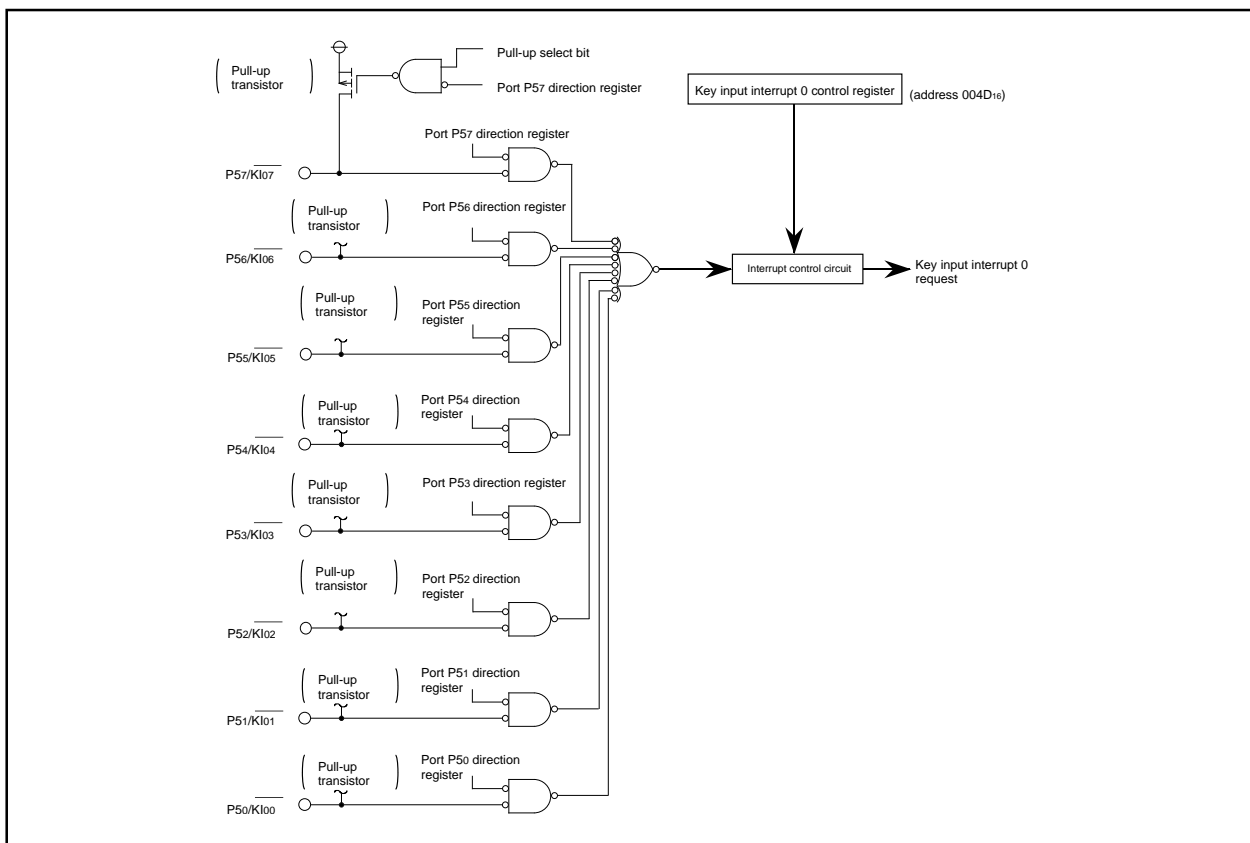
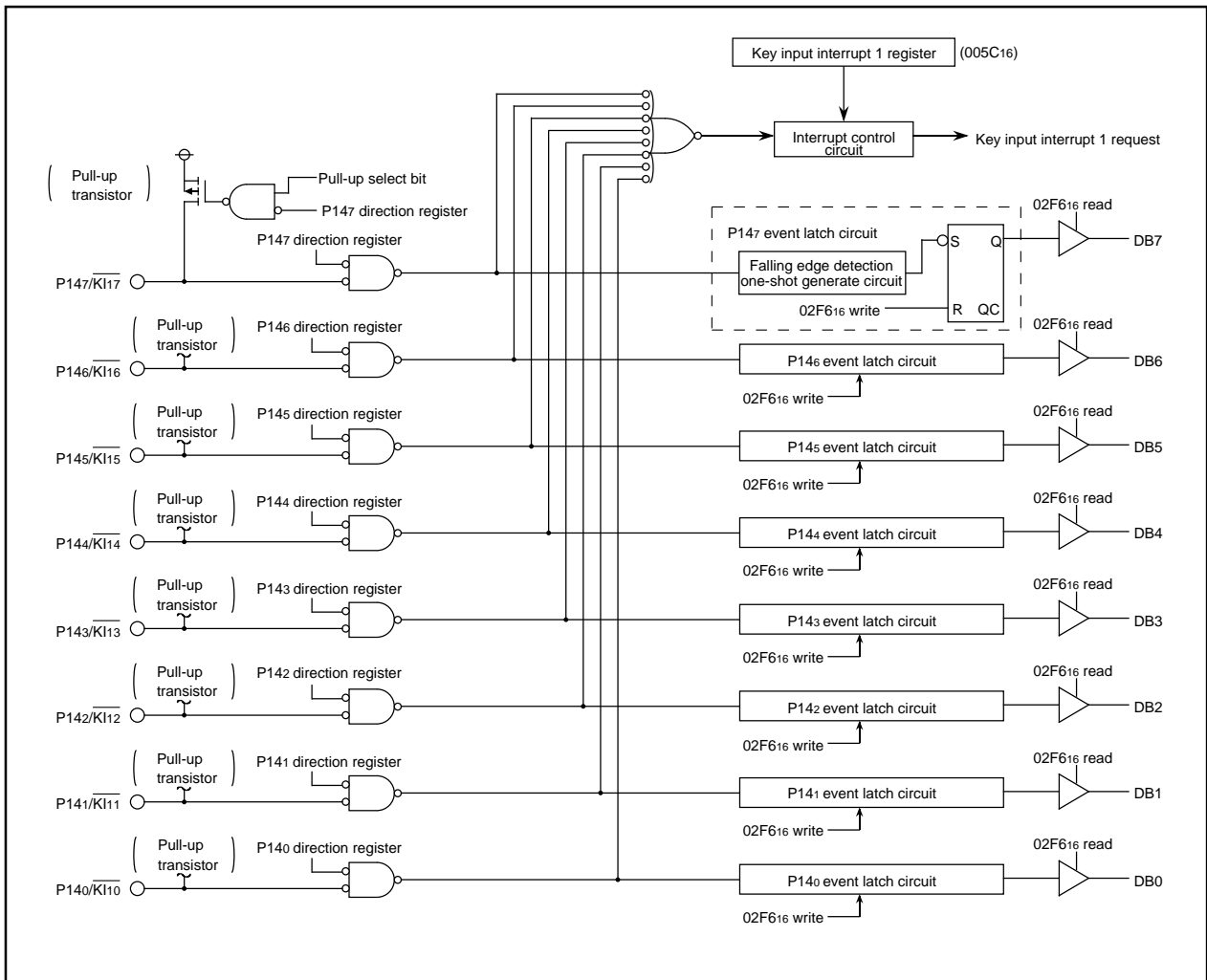
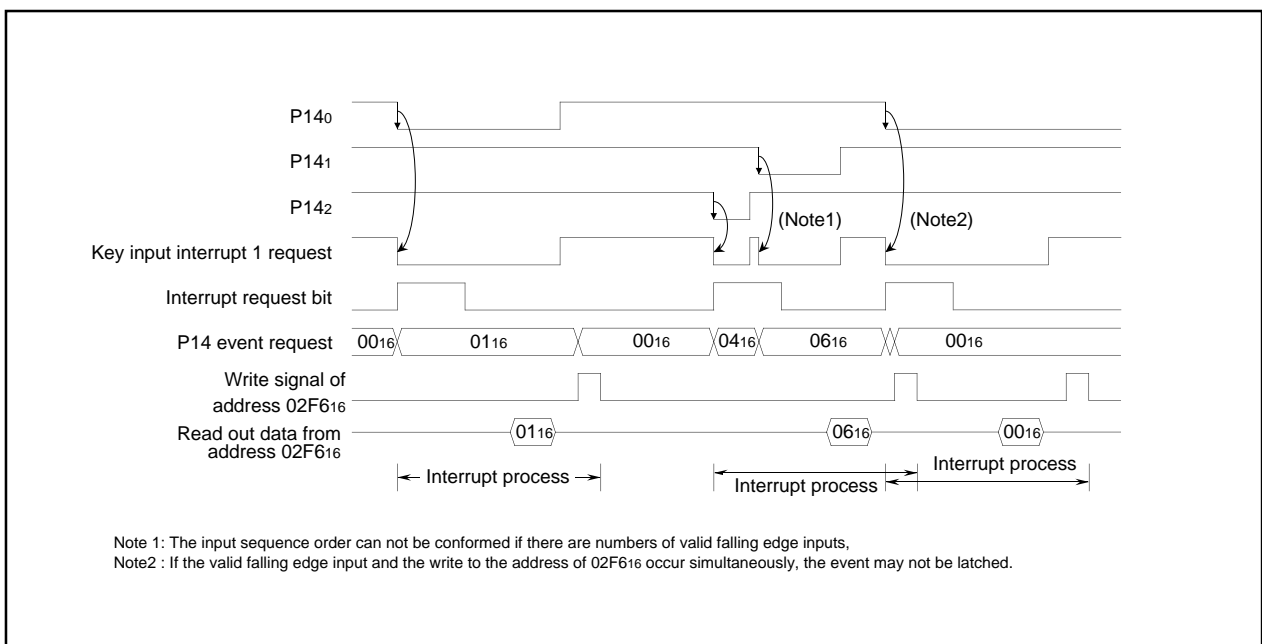

Fig.DD-14 Block diagram of key input interrupt 0



**Fig.DD-15 Block diagram of key input interrupt 1**



**Fig.DD-16 Block diagram of key input interrupt 1**

### Address Match Interrupt

An address match interrupt is generated when the address match interrupt address register contents match the program counter value. Two address match interrupts can be set, each of which can be enabled and disabled by an address match interrupt enable bit. Address match interrupts are not affected by the interrupt enable flag (I flag) and processor interrupt priority level (IPL). The stacked value of the program counter (PC) for an address match interrupt varies depending on the instruction being executed.

Fig.DD-17 shows the address match interrupt-related registers.

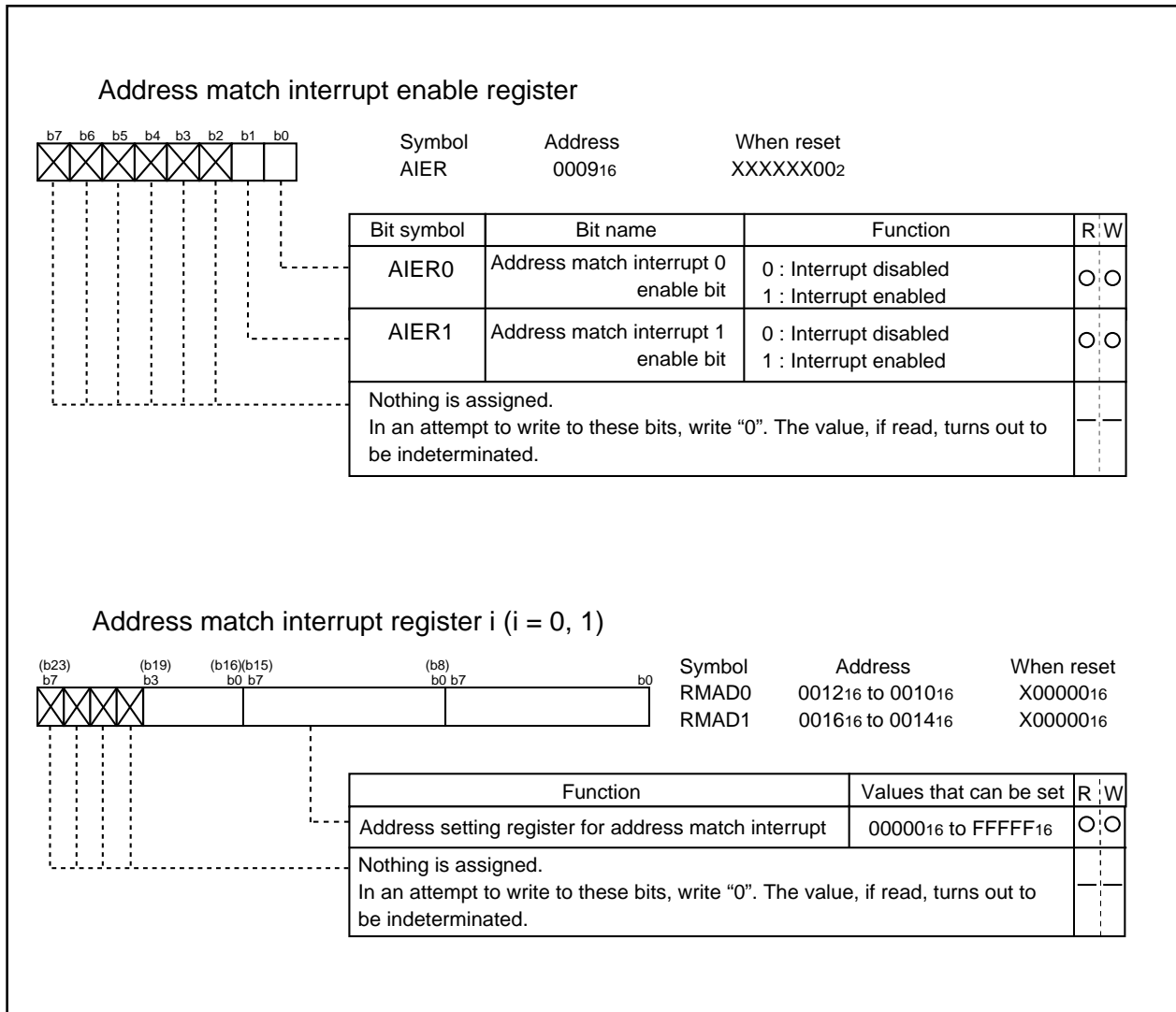

Fig.DD-17 Address match interrupt-related registers

## Precautions for Interrupts

### (1) Reading address 00000<sub>16</sub>

- When maskable interrupt is occurred, CPU read the interrupt information (the interrupt number and interrupt request level) in the interrupt sequence.

The interrupt request bit of the certain interrupt written in address 00000<sub>16</sub> will then be set to "0".

Reading address 00000<sub>16</sub> by software sets the request bit, which the interrupt source is enabled with the highest priority, to "0".

Though the interrupt is generated, the interrupt routine may not be executed.

Hence do not read address 00000<sub>16</sub> by software.

### (2) Setting the stack pointer

- The value of the stack pointer is initialized to 0000<sub>16</sub> right after the reset. Accepting an interrupt before setting a value in the stack pointer may become a factor of runaway. Be sure to set a value in the stack pointer before accepting an interrupt. When using the  $\overline{\text{NMI}}$  interrupt, initialize the stack point at the beginning of a program. Concerning the first instruction immediately after reset, generating any interrupts including the  $\overline{\text{NMI}}$  interrupt is prohibited.

### (3) The $\overline{\text{NMI}}$ interrupt

- As for the  $\overline{\text{NMI}}$  interrupt pin, an interrupt cannot be disabled. Connect it to the Vcc pin via a resistor (pull-up) if unused. Be sure to work on it.
- The  $\overline{\text{NMI}}$  pin also serves as P85, which is exclusively input. Reading the contents of the P8 register allows reading the pin value. Use the reading of this pin only for establishing the pin level at the time when the  $\overline{\text{NMI}}$  interrupt is input.
- Do not reset the CPU with the input to the  $\overline{\text{NMI}}$  pin being in the "L" state.
- Do not attempt to go into stop mode with the input to the  $\overline{\text{NMI}}$  pin being in the "L" state. With the input to the  $\overline{\text{NMI}}$  being in the "L" state, the CM10 is fixed to "0", so attempting to go into stop mode is turned down.
- Do not attempt to go into wait mode with the input to the  $\overline{\text{NMI}}$  pin being in the "L" state. With the input to the  $\overline{\text{NMI}}$  pin being in the "L" state, the CPU stops but the oscillation does not stop, so no power is saved. In this instance, the CPU is returned to the normal state by a later interrupt.
- Signals input to the  $\overline{\text{NMI}}$  pin require an "L" level of 1 clock or more, from the operation clock of the CPU.

### (4) External interrupt

- Either an "L" level or an "H" level of at least 380 ns width is necessary for the signal input to pins  $\overline{\text{INT}}_0$  through  $\overline{\text{INT}}_{11}$  regardless of the CPU operation clock.
- When the polarity of the  $\overline{\text{INT}}_0$  to  $\overline{\text{INT}}_{11}$  pins is changed, the interrupt request bit is sometimes set to "1". After changing the polarity, set the interrupt request bit to "0". Fig.DD-18 shows the procedure for changing the  $\overline{\text{INT}}$  interrupt generate factor.

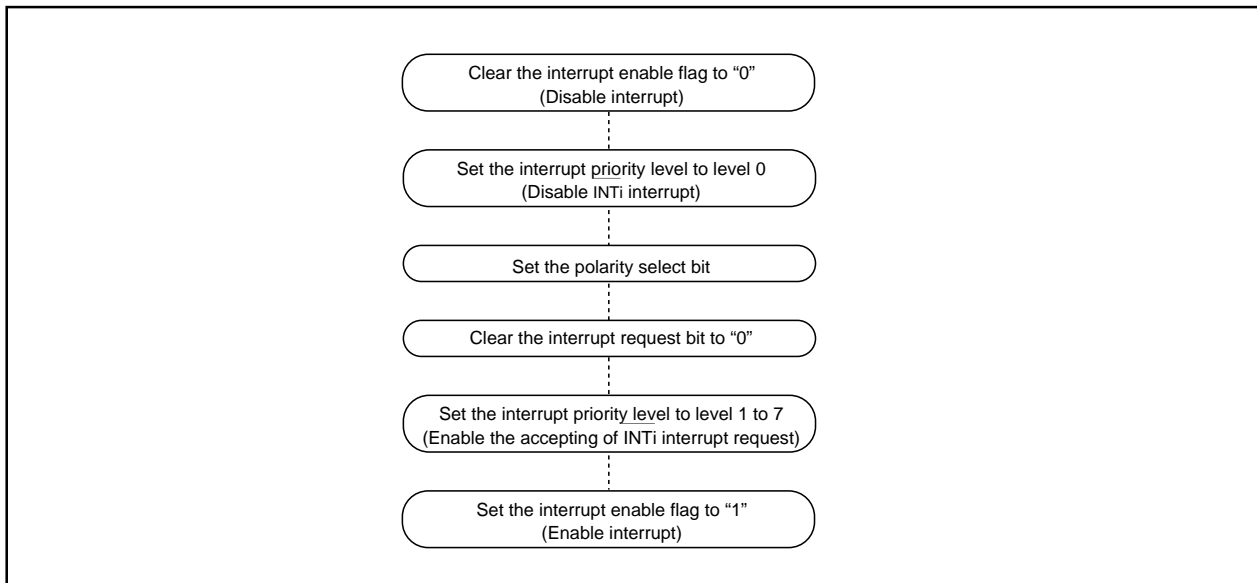

Fig.DD-18 Switching condition of INT interrupt request

(5) Rewrite the interrupt control register

- To rewrite the interrupt control register, do so at a point that does not generate the interrupt request for that register. If there is possibility of the interrupt request occurs, rewrite the interrupt control register after the interrupt is disabled. The program examples are described as follow:

- When a instruction to rewrite the interrupt control register is executed when the interrupt is disabled, the

**Example 1:**

```

INT_SWITCH1:
  FCLR  I           ; Disable interrupts.
  AND.B #00h, 0055h ; Clear TA0IC int. priority level and int. request bit.
  NOP                               ; Four NOP instructions are required when using HOLD function.
  NOP
  FSET  I           ; Enable interrupts.
  
```

**Example 2:**

```

INT_SWITCH2:
  FCLR  I           ; Disable interrupts.
  AND.B #00h, 0055h ; Clear TA0IC int. priority level and int. request bit.
  MOV.W MEM, R0     ; Dummy read.
  FSET  I           ; Enable interrupts.
  
```

**Example 3:**

```

INT_SWITCH3:
  PUSHC FLG        ; Push Flag register onto stack
  FCLR  I           ; Disable interrupts.
  AND.B #00h, 0055h ; Clear TA0IC int. priority level and int. request bit.
  POPC  FLG        ; Enable interrupts.
  
```

The reason why two NOP instructions (four when using the HOLD function) or dummy read are inserted before FSET I in Examples 1 and 2 is to prevent the interrupt enable flag I from being set before the interrupt control register is rewritten due to effects of the instruction queue.

interrupt request bit is not set sometimes even if the interrupt request for that register has been generated. This will depend on the instruction. If this creates problems, use the below instructions to change the register.

Instructions : AND, OR, BCLR, BSET

## Watchdog Timer

The watchdog timer has the function of detecting when the program is out of control. The watchdog timer is a 15-bit counter which down-counts the clock derived by dividing the BCLK using the prescaler. A watchdog timer interrupt is generated when an underflow occurs in the watchdog timer. When XIN is selected for the BCLK, bit 7 of the watchdog timer control register (address 000F16) selects the prescaler division ratio (by 16 or by 128). When XCIN is selected as the BCLK, the prescaler is set for division by 2 regardless of bit 7 of the watchdog timer control register (address 000F16). Thus the watchdog timer's period can be calculated as given below. The watchdog timer's period is, however, subject to an error due to the pre-scaler.

### With XIN chosen for BCLK

$$\text{Watchdog timer period} = \frac{\text{pre-scaler dividing ratio (16 or 128)} \times \text{watchdog timer count (32768)}}{\text{BCLK}}$$

### With XCIN chosen for BCLK

$$\text{Watchdog timer period} = \frac{\text{pre-scaler dividing ratio (2)} \times \text{watchdog timer count (32768)}}{\text{BCLK}}$$

For example, suppose that BCLK runs at 10 MHz and that 16 has been chosen for the dividing ratio of the pre-scaler, then the watchdog timer's period becomes approximately 52.4 ms.

The watchdog timer is initialized by writing to the watchdog timer start register (address 000E16) and when a watchdog timer interrupt request is generated. The prescaler is initialized only when the microcomputer is reset. After a reset is cancelled, the watchdog timer and prescaler are both stopped. The count is started by writing to the watchdog timer start register (address 000E16).

Fig.DG-1 shows the block diagram of the watchdog timer. Fig.DG-2 shows the watchdog timer-related registers.

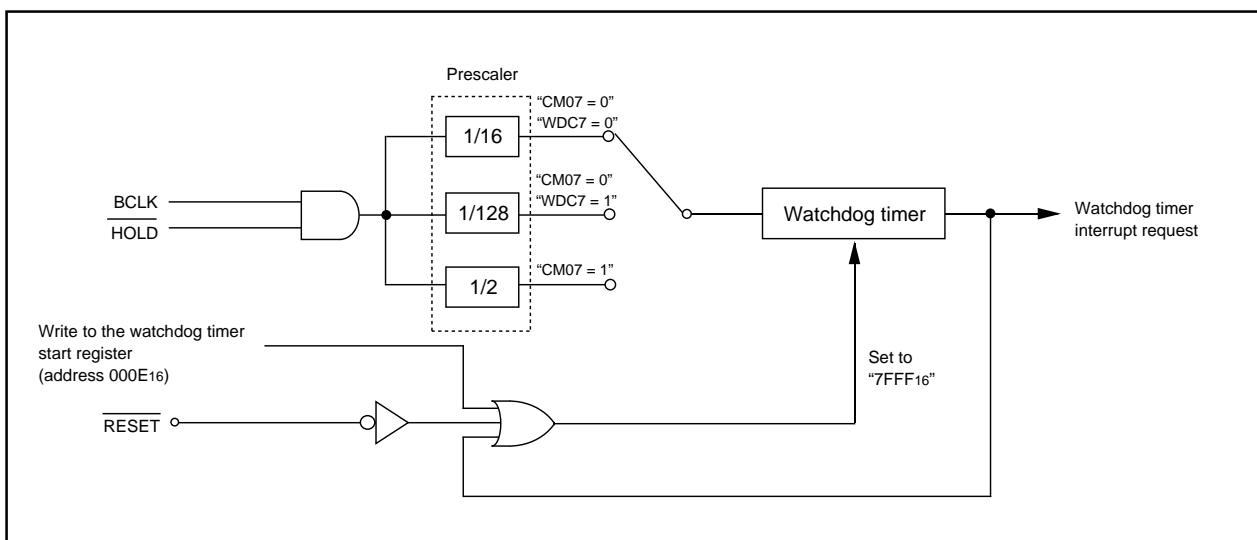

Fig.DG-1 Block diagram of watchdog timer



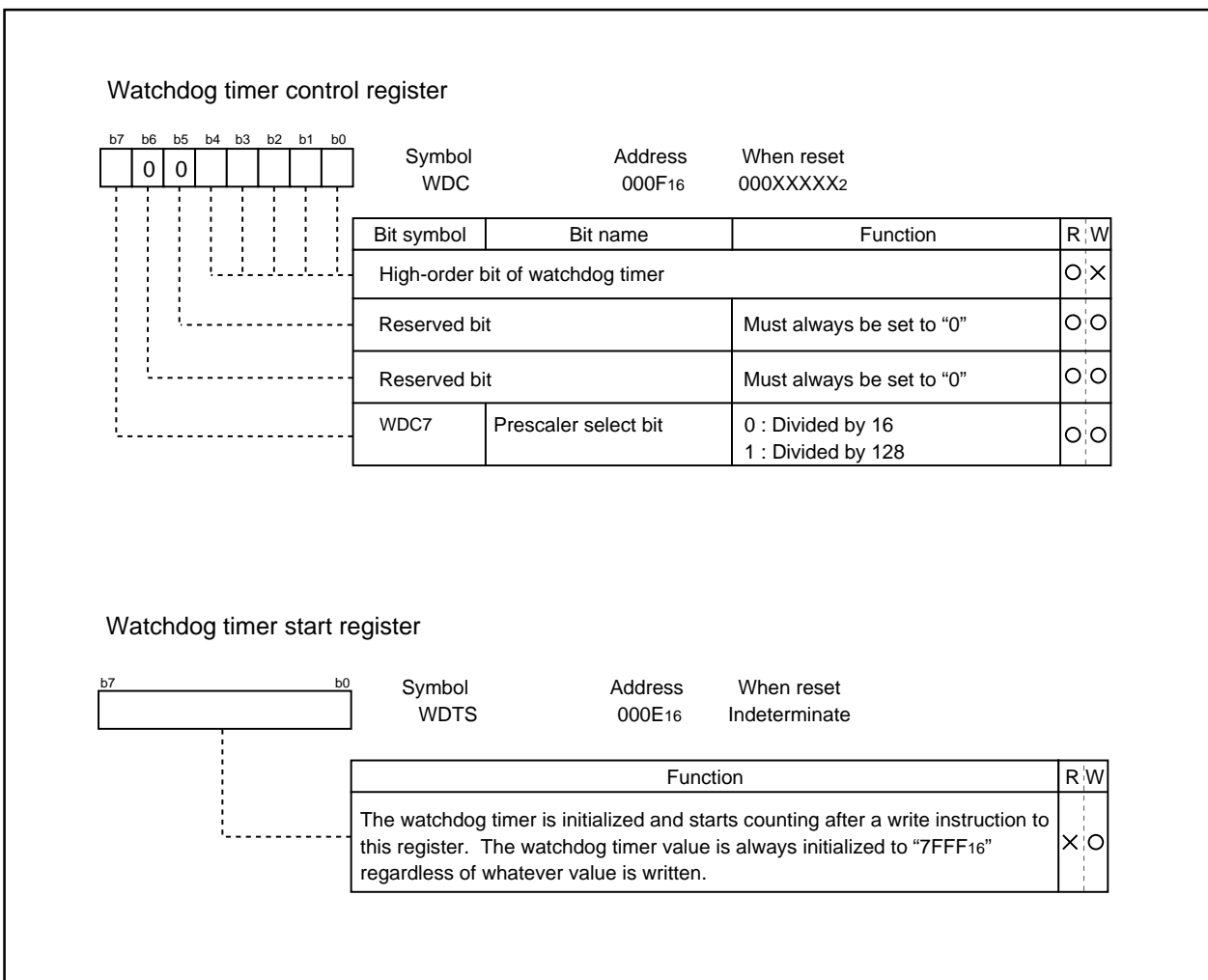

Fig.DG-2 Watchdog timer control and start registers

## DMAC

This microcomputer has two DMAC (direct memory access controller) channels that allow data to be sent to memory without using the CPU. DMAC shares the same data bus with the CPU. The DMAC is given a higher right of using the bus than the CPU, which leads to working the cycle stealing method. On this account, the operation from the occurrence of DMA transfer request signal to the completion of 1-word (16-bit) or 1-byte (8-bit) data transfer can be performed at high speed. Fig.EC-1 shows the block diagram of the DMAC. Table.EC-1 shows the DMAC specifications. Fig.EC-2 to EC-4 show the registers used by the DMAC.

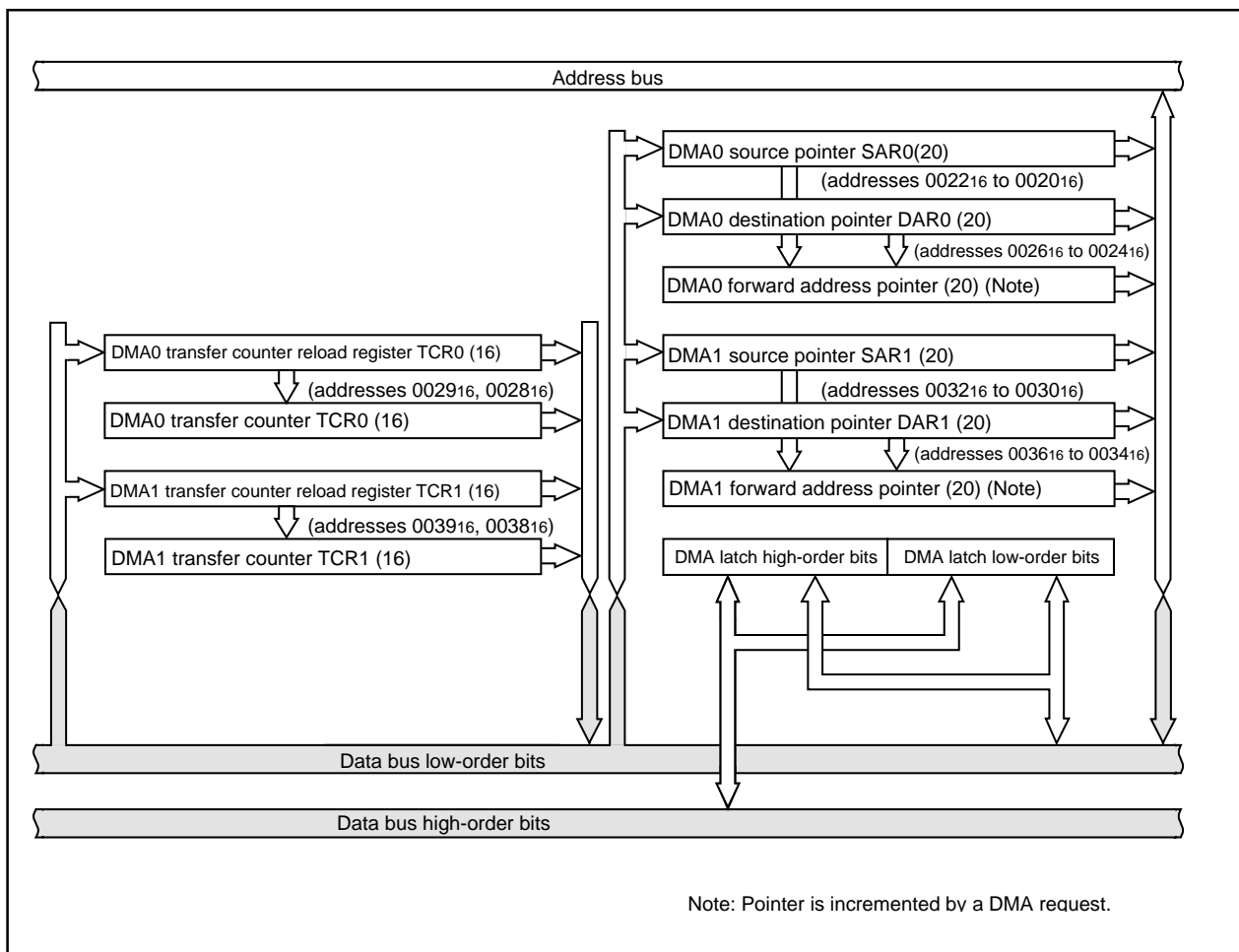

Fig.EC-1 Block diagram of DMAC

Either a write signal to the software DMA request bit or an interrupt request signal is used as a DMA transfer request signal. But the DMA transfer is affected neither by the interrupt enable flag (I flag) nor by the interrupt priority level. The DMA transfer doesn't affect any interrupts neither.

If the DMAC is active (the DMA enable bit is set to 1), data transfer starts every time a DMA transfer request signal occurs. If the cycle of the occurrences of DMA transfer request signals is higher than the DMA transfer cycle, there can be instances in which the number of transfer requests doesn't agree with the number of transfers. For details, see the description of the DMA request bit.

Table.EC-1 DMAC specifications

Item	Specification
No. of channels	2 (cycle steal method)
Transfer memory space	<ul style="list-style-type: none"> <li>From any address in the 1M bytes space to a fixed address</li> <li>From a fixed address to any address in the 1M bytes space</li> <li>From a fixed address to a fixed address</li> </ul> (Note that DMA-related registers [0020 <sub>16</sub> to 003F <sub>16</sub> ] cannot be accessed)
Maximum No. of bytes transferred	128K bytes (with 16-bit transfers) or 64K bytes (with 8-bit transfers)
DMA request factors (Note)	Falling edge of INT <sub>0</sub> or INT <sub>1</sub> or both edge Timer A0 to timer A4 interrupt requests Timer B0 to timer B5 interrupt requests UART0 transfer and reception interrupt requests UART1 transfer and reception interrupt requests UART2 transfer and reception interrupt requests Serial I/O3, 4 interrupt requests A-D conversion interrupt requests IBF0 to IBF3 interrupt requests Software triggers
Channel priority	DMA0 takes precedence if DMA0 and DMA1 requests are generated simultaneously
Transfer unit	8 bits or 16 bits
Transfer address direction	forward/fixed (forward direction cannot be specified for both source and destination simultaneously)
Transfer mode	<ul style="list-style-type: none"> <li>Single transfer mode After the transfer counter underflows, the DMA enable bit turns to "0", and the DMAC turns inactive</li> <li>Repeat transfer mode After the transfer counter underflows, the value of the transfer counter reload register is reloaded to the transfer counter. The DMAC remains active unless a "0" is written to the DMA enable bit.</li> </ul>
DMA interrupt request generation timing	When an underflow occurs in the transfer counter
Active	When the DMA enable bit is set to "1", the DMAC is active. When the DMAC is active, data transfer starts every time a DMA transfer request signal occurs.
Inactive	<ul style="list-style-type: none"> <li>When the DMA enable bit is set to "0", the DMAC is inactive.</li> <li>After the transfer counter underflows in single transfer mode</li> </ul>
Forward address pointer and reload timing for transfer counter	At the time of starting data transfer immediately after turning the DMAC active, the value of one of source pointer and destination pointer - the one specified for the forward direction - is reloaded to the forward direction address pointer, and the value of the transfer counter reload register is reloaded to the transfer counter.
Writing to register	Registers specified for forward direction transfer are always write enabled. Registers specified for fixed address transfer are write-enabled when the DMA enable bit is "0".
Reading the register	Can be read at any time. However, when the DMA enable bit is "1", reading the register set up as the forward register is the same as reading the value of the forward address pointer.

Note: DMA transfer is not effective to any interrupt. DMA transfer is affected neither by the interrupt enable flag (I flag) nor by the interrupt priority level.

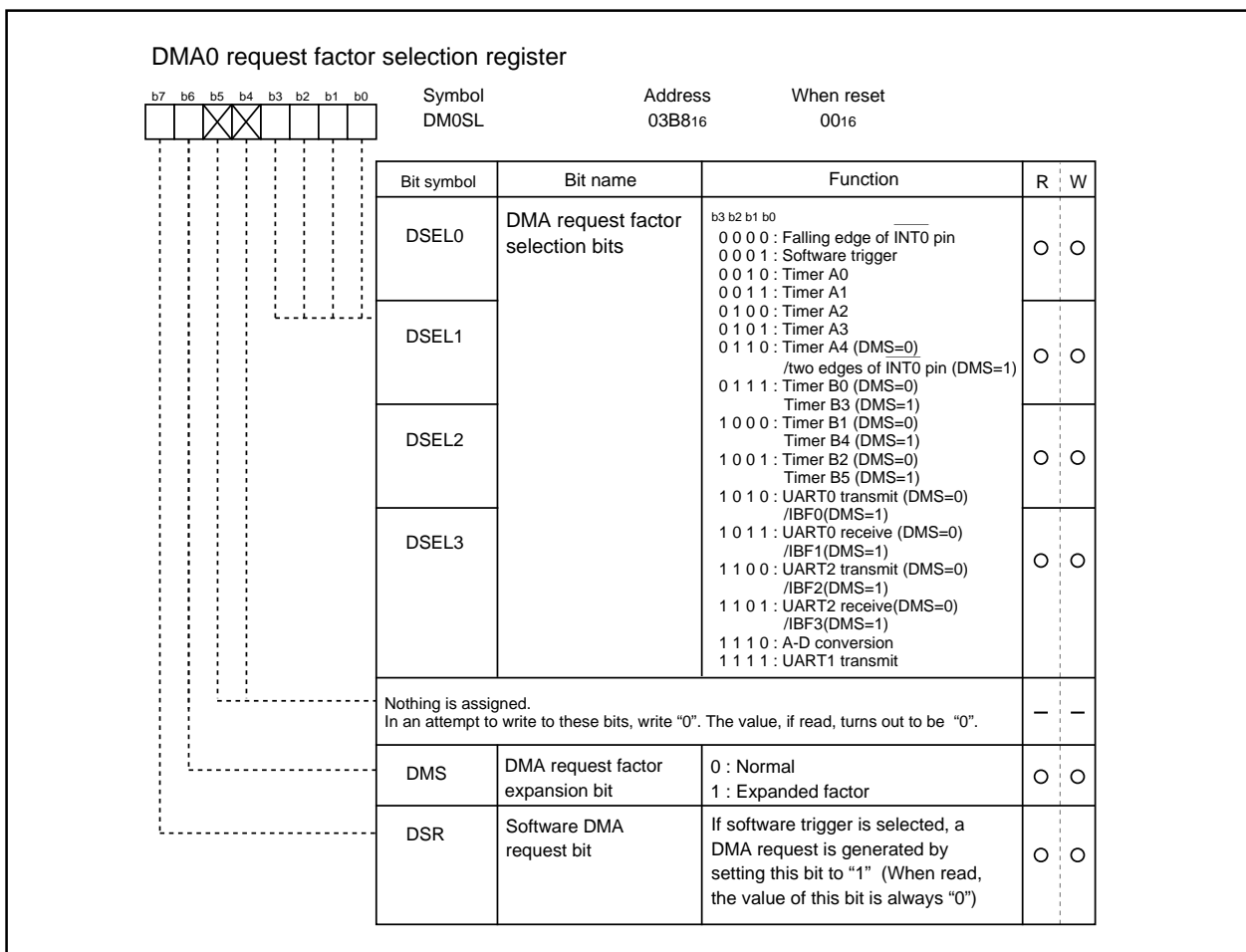

**Fig.EC-2 DMAC register (1)**

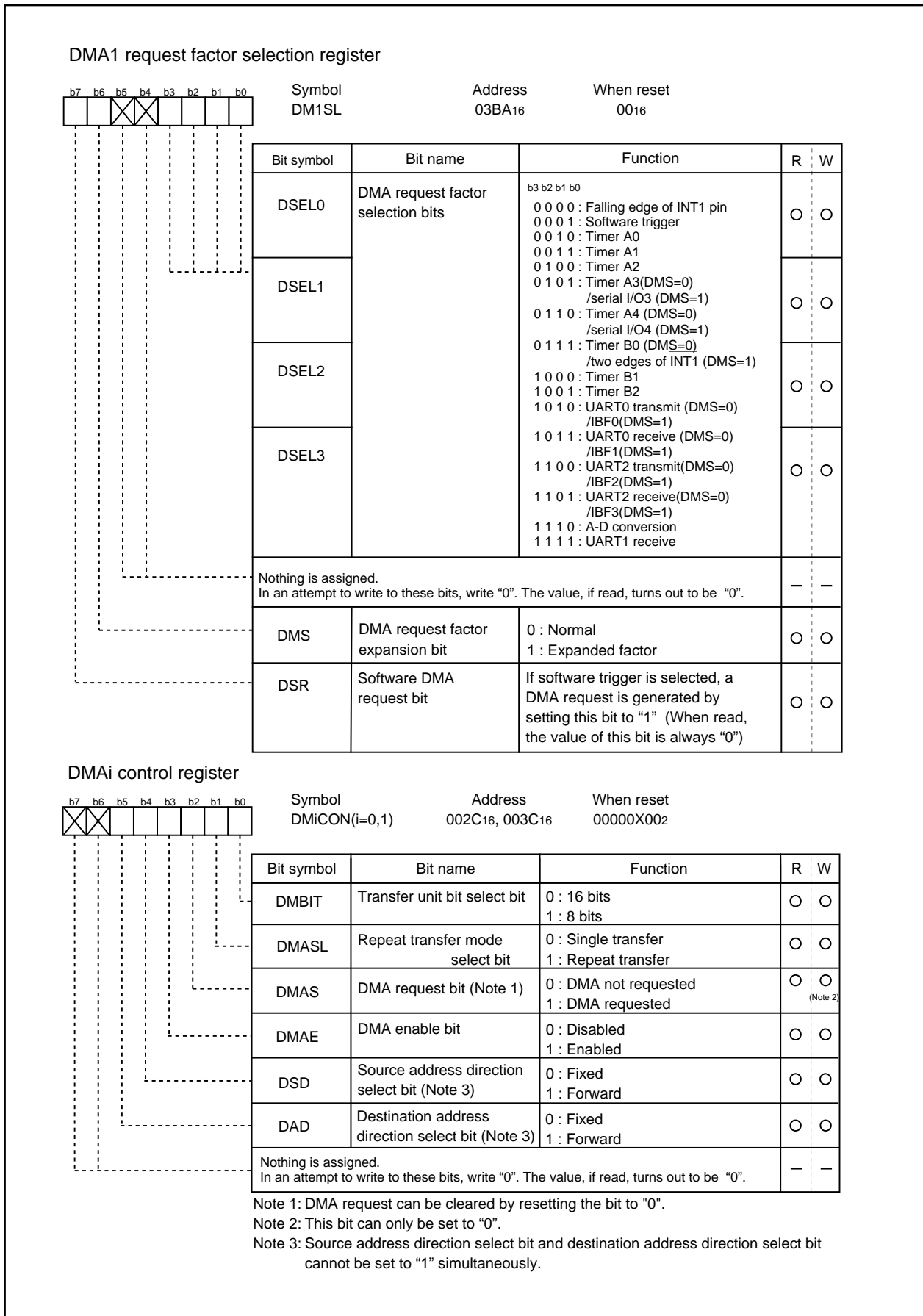

Fig.EC-3 DMAC register (2)

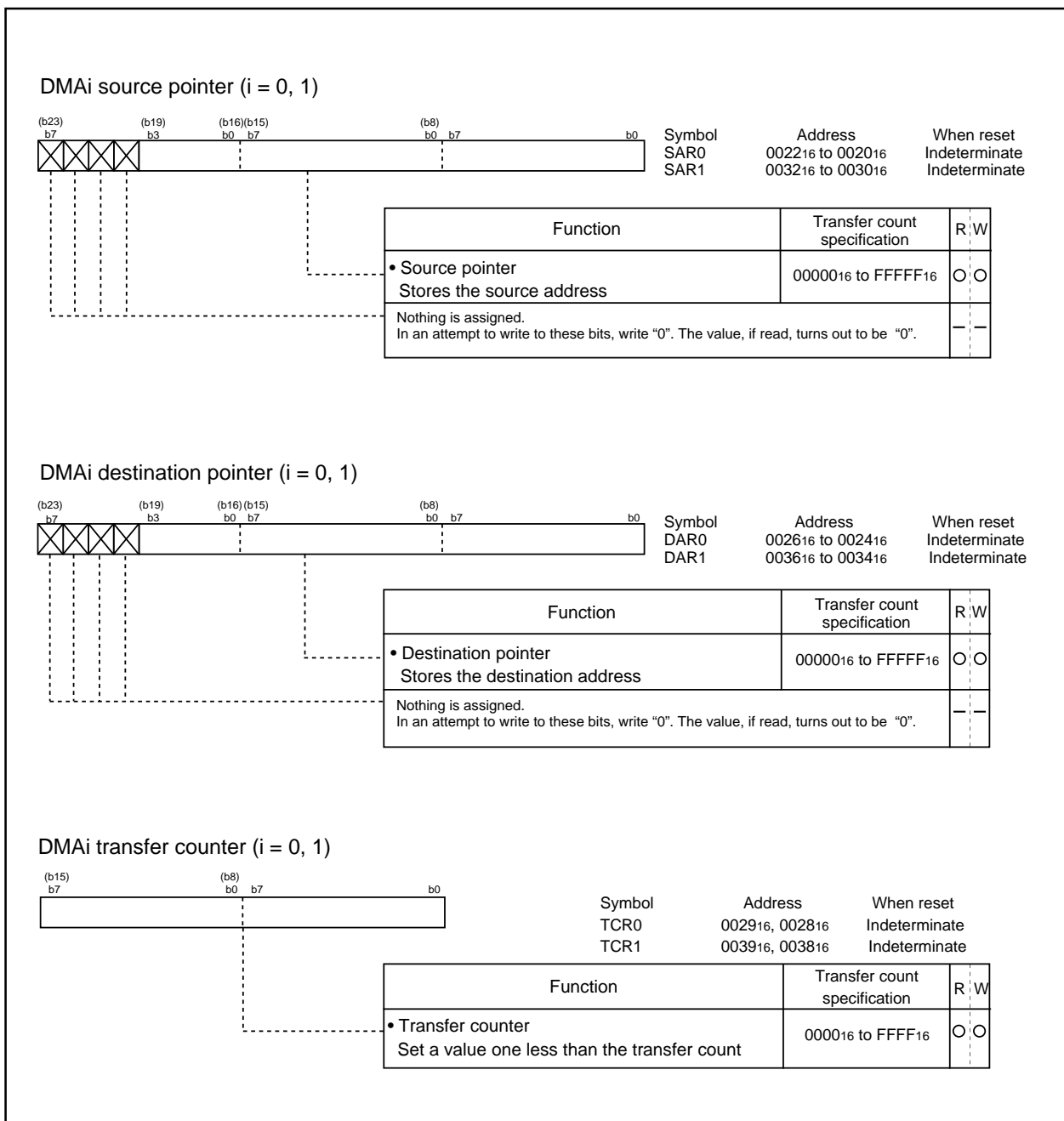

Fig.EC-4 DMAC register (3)

## (1) Transfer cycle

The transfer cycle consists of the bus cycle in which data is read from memory or from the SFR area (source read) and the bus cycle in which the data is written to memory or to the SFR area (destination write). The number of read and write bus cycles depends on the source and destination addresses.

\* Effect of source and destination addresses

When 16-bit data is transferred on a 16-bit data bus, and the source and destination both start at odd addresses, there are one more source read cycle and destination write cycle than when the source and destination both start at even addresses.

Fig.EC-5 shows the example of the transfer cycles for a source read. For convenience, the destination write cycle is shown as one cycle and the source read cycles for the different conditions are shown. In reality, the destination write cycle is subject to the same conditions as the source read cycle, with the transfer cycle changing accordingly. When calculating the transfer cycle, remember to apply the respective conditions to both the destination write cycle and the source read cycle. For example (2) in Fig.EC-5, if data are being transferred in 16-bit units on an 8-bit bus, two bus cycles are required for both the source read cycle and the destination write cycle.

## (2) DMAC transfer cycles

Any combination of even or odd transfer read and write addresses is possible. Table.EC-2 shows the number of DMAC transfer cycles.

The number of DMAC transfer cycles can be calculated as follows:

$$\text{No. of transfer cycles per transfer unit} = \text{No. of read cycles} \times j + \text{No. of write cycles} \times k$$

**Table.EC-2 No. of DMAC transfer cycles**

Transfer unit	Bus width	Access address	Single-chip mode		Memory expansion mode Microprocessor mode	
			No. of read cycles	No. of write cycles	No. of read cycles	No. of write cycles
8-bit transfers (DMBIT= "1")	16-bit (BYTE= "L")	Even	1	1	1	1
		Odd	1	1	1	1
	8-bit (BYTE = "H")	Even	—	—	1	1
		Odd	—	—	1	1
16-bit transfers (DMBIT= "0")	16-bit (BYTE = "L")	Even	1	1	1	1
		Odd	2	2	2	2
	8-bit (BYTE = "H")	Even	—	—	2	2
		Odd	—	—	2	2

### Coefficient j, k

Internal memory			External memory		
Internal ROM/RAM No wait	Internal ROM/RAM With wait	SFR area	Separate bus No wait	Separate bus With wait	Multiplex bus
1	2	2	1	2	3

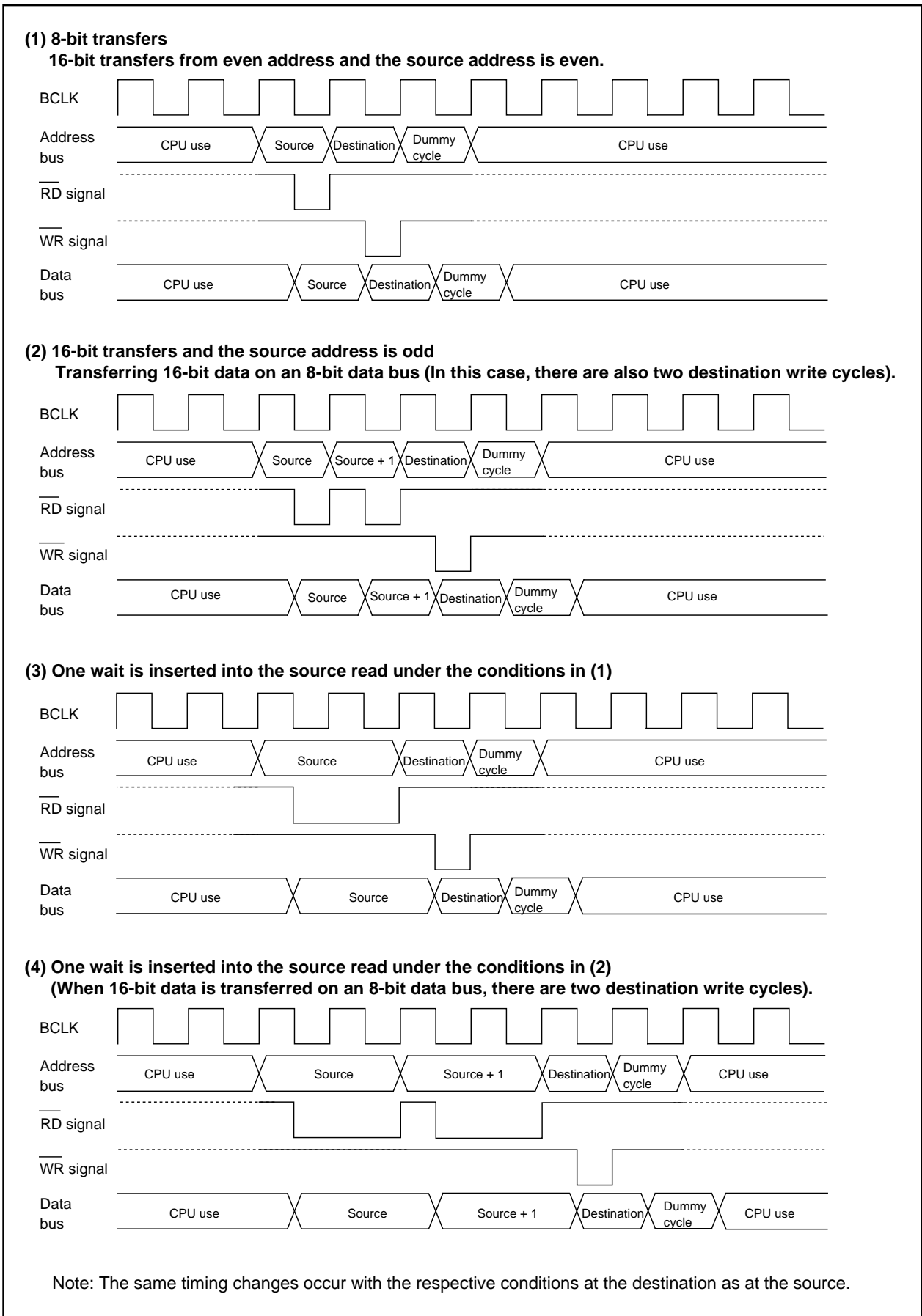

Fig.EC-5 Example of the transfer cycles for a source read



**DMA enable bit**

Setting the DMA enable bit to "1" makes the DMAC active. The DMAC carries out the following operations at the time data transfer starts immediately after DMAC is turned active.

(1) Reloads the value of one of the source pointer and the destination pointer - the one specified for the forward direction - to the forward direction address pointer.

(2) Reloads the value of the transfer counter reload register to the transfer counter.

Thus overwriting "1" to the DMA enable bit with the DMAC being active carries out the operations given above, so the DMAC operates again from the initial state at the instant "1" is overwritten to the DMA enable bit.

**DMA request bit**

The DMAC can generate a DMA transfer request signal triggered by a factor chosen in advance out of DMA request factors for each channel.

DMA request factors include the following.

\* Factors effected by using the interrupt request signals from the built-in peripheral functions and software DMA factors (internal factors) effected by a program.

\* External factors effected by utilizing the input from external interrupt signals.

For the selection of DMA request factors, see the descriptions of the DMAi factor selection register.

The DMA request bit turns to "1" if the DMA transfer request signal occurs regardless of the DMAC's state (regardless of whether the DMA enable bit is set "1" or to "0"). It turns to "0" immediately before data transfer starts.

In addition, it can be set to "0" by use of a program, but cannot be set to "1".

There can be instances in which a change in DMA request factor selection bit causes the DMA request bit to turn to "1". So be sure to set the DMA request bit to "0" after the DMA request factor selection bit is changed.

The DMA request bit turns to "1" if a DMA transfer request signal occurs, and turns to "0" immediately just before data transfer starts. If the DMAC is active, data transfer starts immediately, so the value of the DMA request bit, if read by use of a program, turns out to be "0" in most cases. To examine whether the DMAC is active, read the DMA enable bit.

Here follows the timing of changes in the DMA request bit.

**(1) Internal factors**

Except the DMA request factors triggered by software, the timing for the DMA request bit to turn to "1" due to an internal factor is the same as the timing for the interrupt request bit of the interrupt control register to turn to "1" due to several factors.

Turning the DMA request bit to "0" due to an internal factor is timed to be effected immediately just before the transfer starts.

**(2) External factors**

An external factor is a factor caused to occur by the edge of input from the INTi pin (i depends on which DMAC channel is used).

Selecting the INTi pins as external factors using the DMA request factor selection bit causes input from these pins to become the DMA transfer request signals.

The timing for the DMA request bit to turn to "1" when an external factor is selected synchronizes with the signal's edge applicable to the function specified by the DMA request factor selection bit (synchronizes with the falling edge of the input signal to each INTi pin, for example).

With an external factor selected, the DMA request bit is timed to turn to "0" immediately just before data transfer starts similarly to the state in which an internal factor is selected.

**(3) The priorities of channels and DMA transfer timing**

If a DMA transfer request signal falls on the same sampling cycle (a sampling cycle means one period from the rising edge to the falling edge of BCLK), the DMA request bits of applicable channels concurrently turn to "1". If the channels are active at that moment, DMA0 is given a high priority to start data transfer. When DMA0 finishes data transfer, it gives the bus right to the CPU. When the CPU finishes single bus access, then DMA1 starts data transfer and gives the bus right to the CPU.

An example in which DMA transfer is carried out in minimum cycles at the time when DMA transfer request signals due to external factors concurrently occur.

Fig.EC-6 An example of DMA transfer effected by external factors.

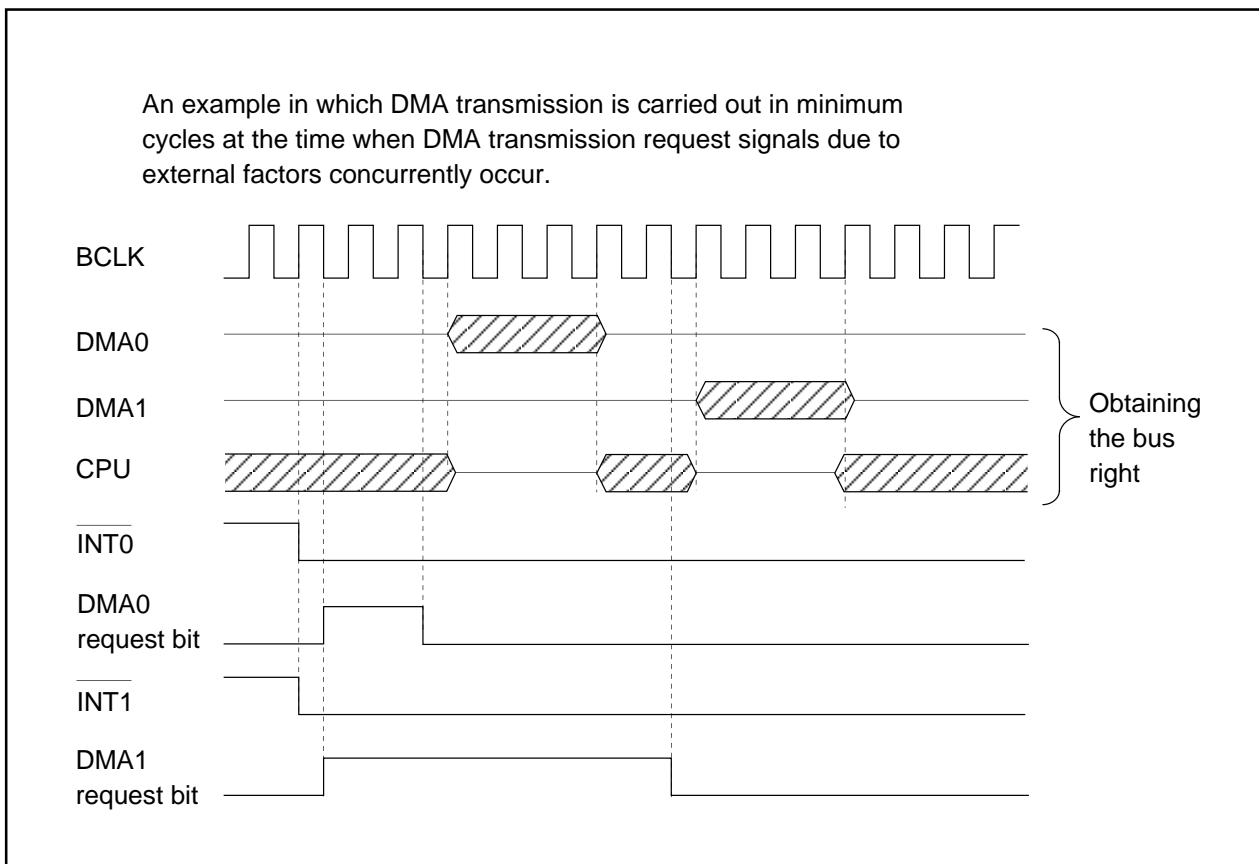

Fig.EC-6 An example of DMA transfer effected by external factors

### Timer

There are eleven 16-bit timers. These timers can be classified by function into timers A (five) and timers B (six). All these timers function independently. Fig.FB-1 and FB-2 show the block diagram of timers.

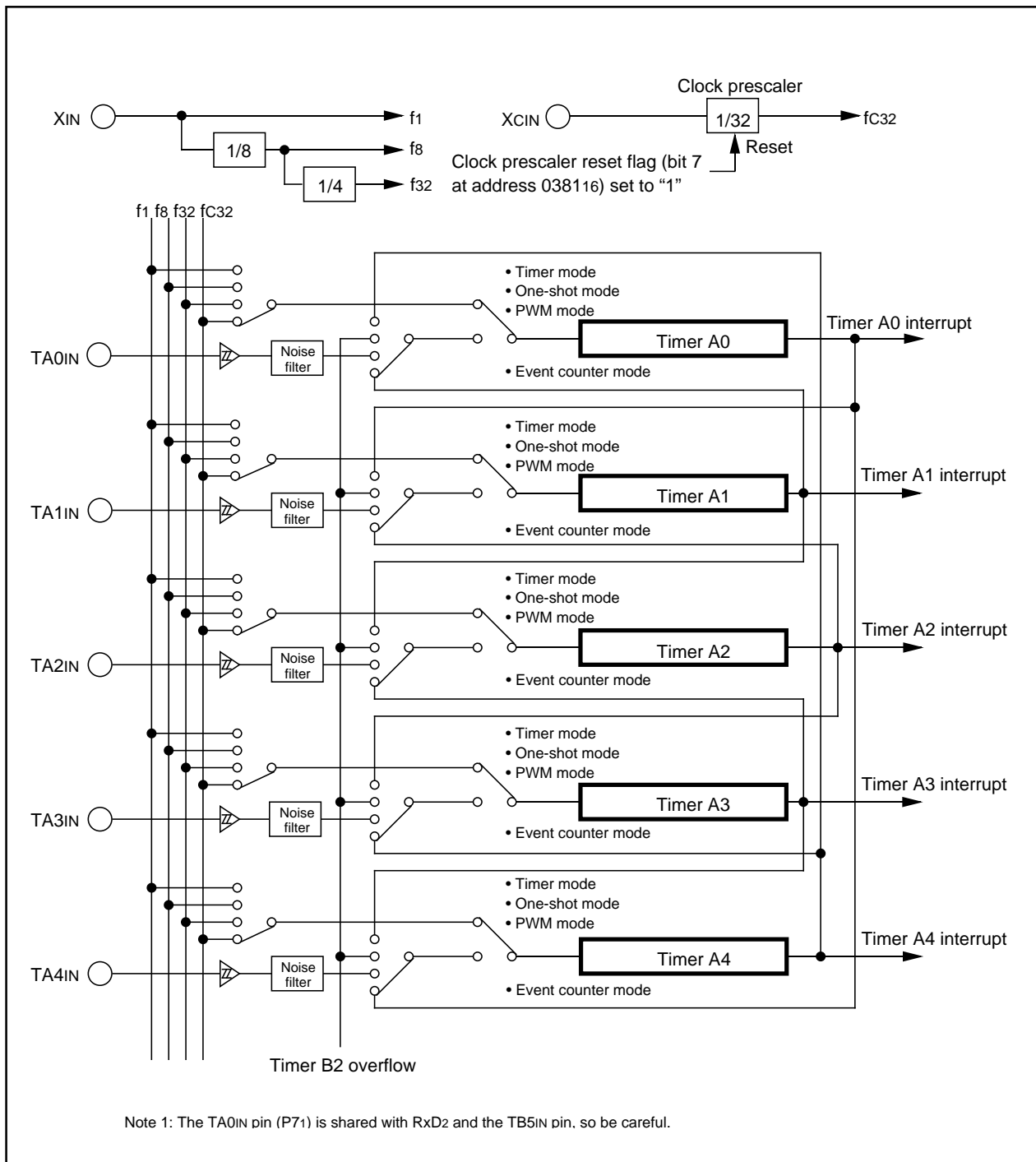
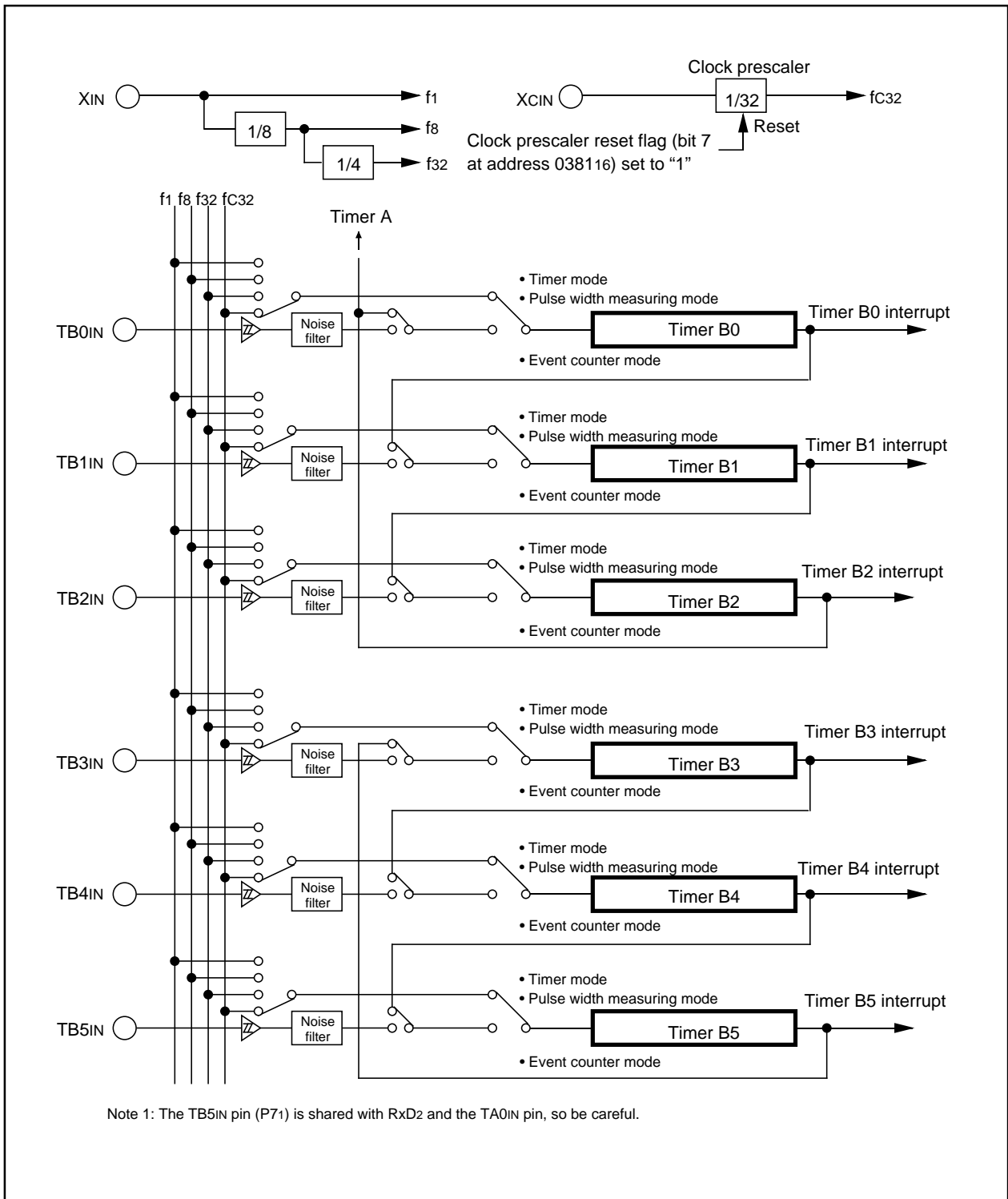

Fig.FB-1 Timer A block diagram



**Fig.FB-2 Timer B block diagram**

### Timer A

Fig.FB-3 shows the block diagram of timer A. Fig.FB-4 to FB-6 show the timer A-related registers.

Except in event counter mode, timers A0 through A4 all have the same function. Use the timer Ai mode register (i = 0 to 4) bits 0 and 1 to choose the desired mode.

Timer A has the four operation modes listed as follows:

- Timer mode: The timer counts an internal count source.
- Event counter mode: The timer counts pulses from an external source or a timer overflow.
- One-shot timer mode: The timer stops counting when the count reaches "0000<sub>16</sub>".
- Pulse width modulation (PWM) mode: The timer continually outputs pulse with arbitrary width.

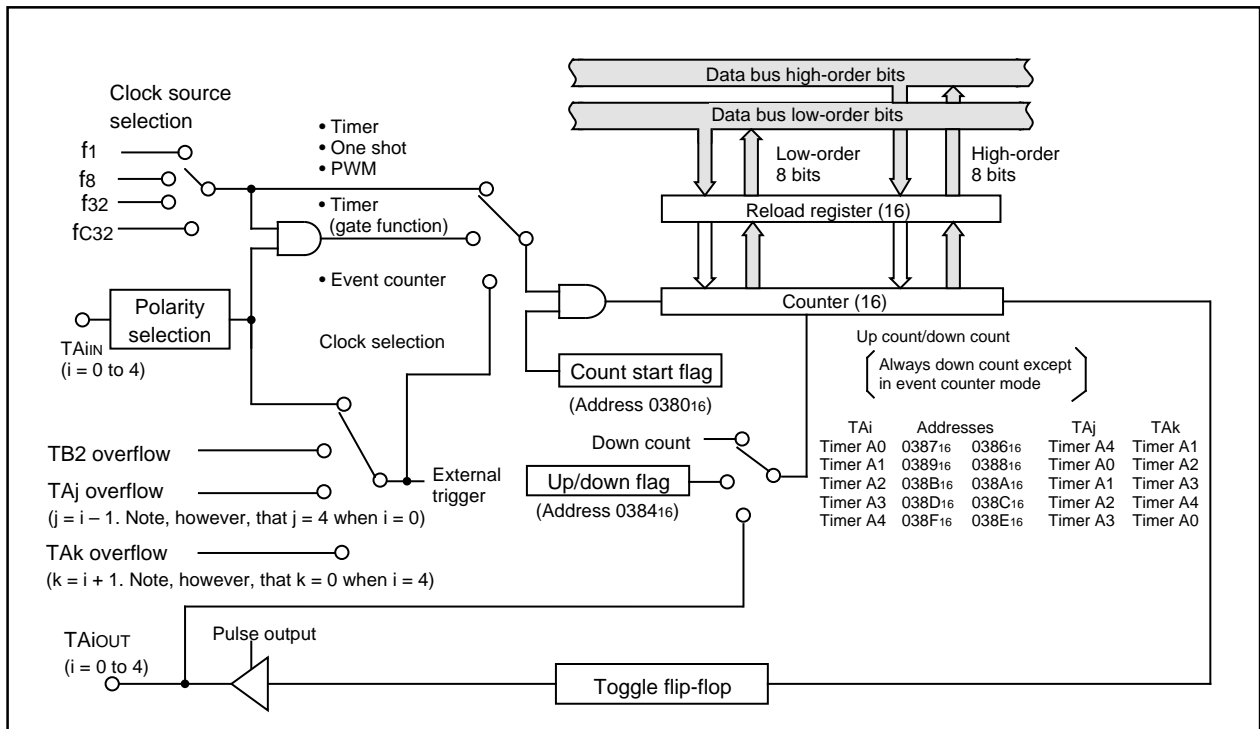

Fig.FB-3 Block diagram of timer A

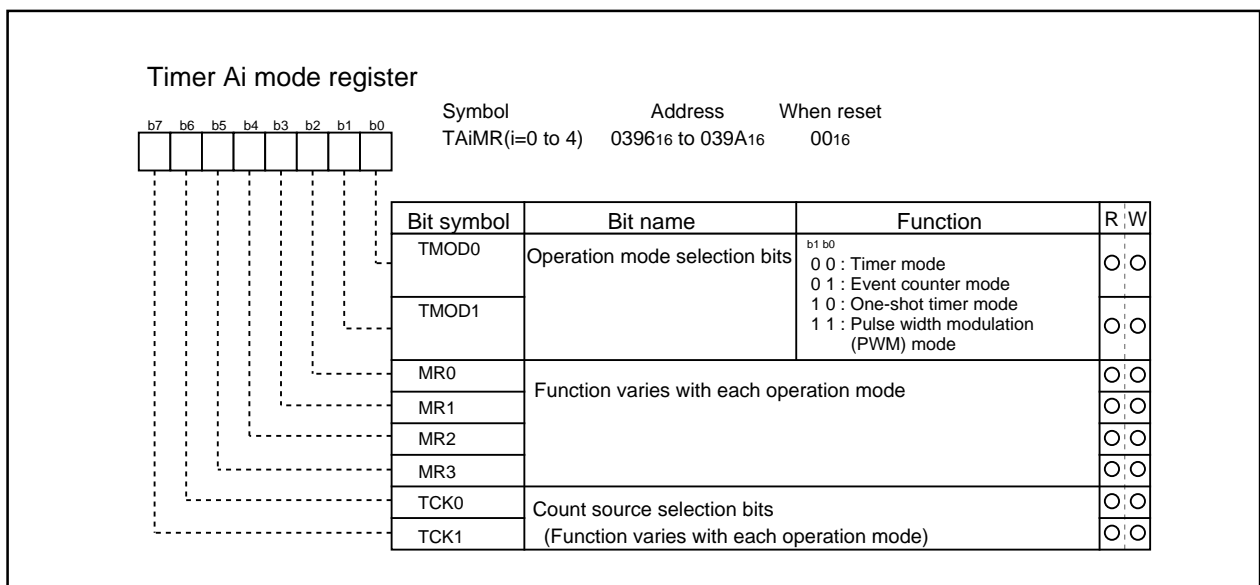

Fig.FB-4 Timer A-related registers (1)

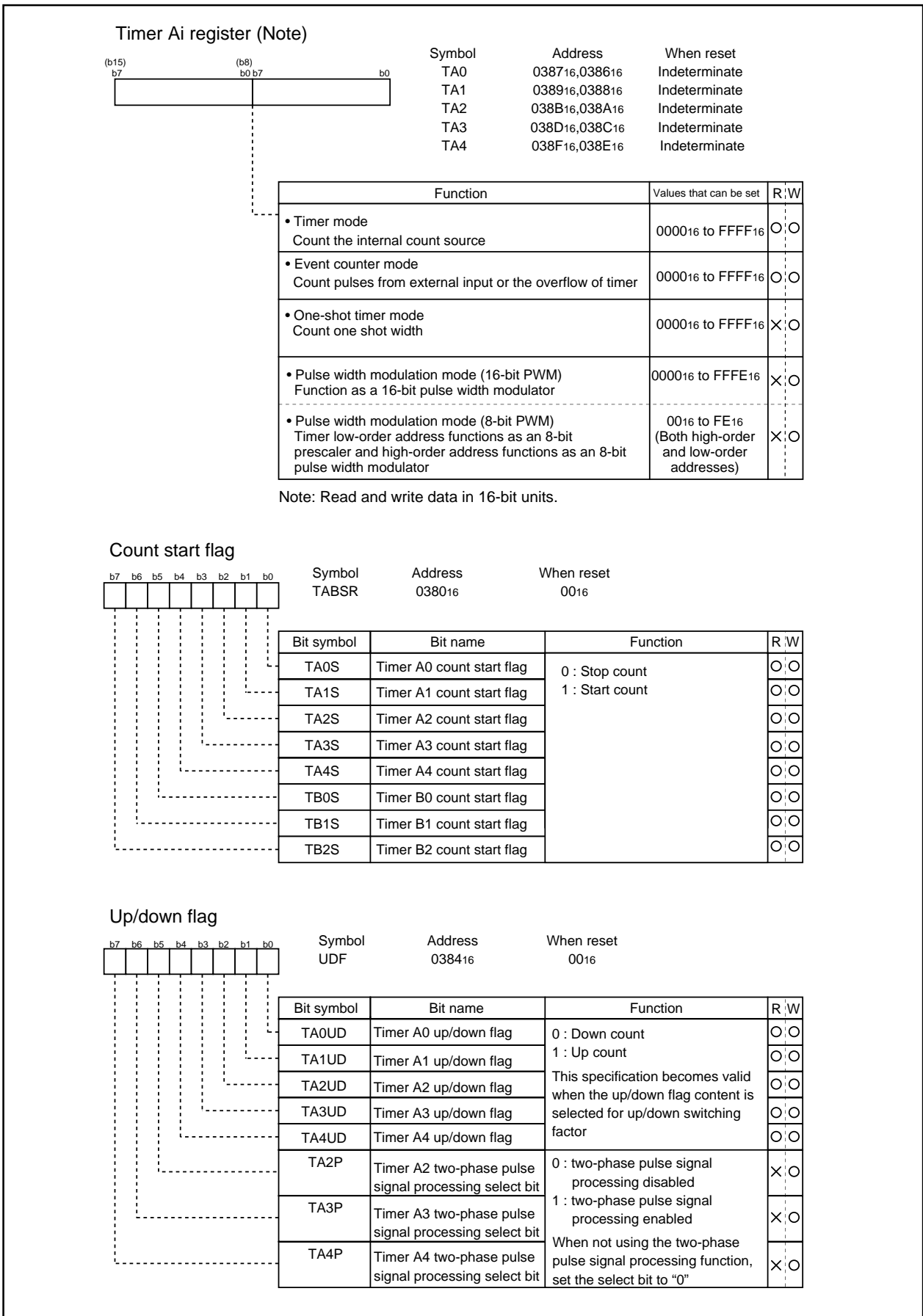

Fig.FB-5 Timer A-related registers (2)

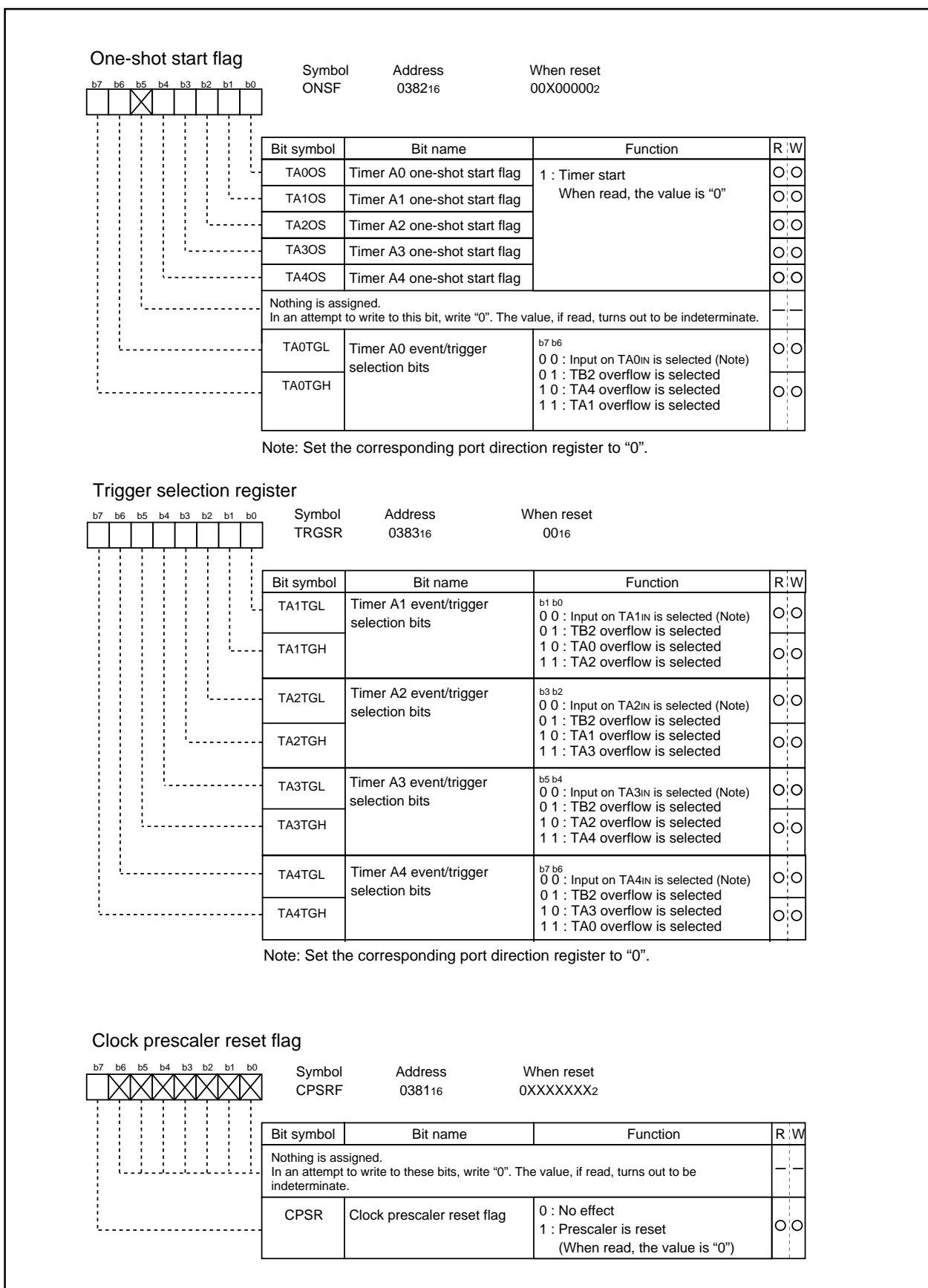

Fig.FB-6 Timer A-related registers (3)

## (1) Timer mode

In this mode, the timer counts an internally generated count source. (See Table.FB-1) Fig.FB-7 shows the timer Ai mode register in timer mode.

**Table.FB-1 Specifications of timer mode**

Item	Specification
Count source	f1, f8, f32, fC32
Count operation	<ul style="list-style-type: none"> <li>• Down count</li> <li>• When the timer underflows, it reloads the reload register contents and then continuing counting</li> </ul>
Divide ratio	1/(n+1) n : Set value
Count start condition	Count start flag is set (= 1)
Count stop condition	Count start flag is reset (= 0)
Interrupt request generation timing	When the timer underflows
TAiIN pin function	Programmable I/O port or gate input
TAiOUT pin function	Programmable I/O port or pulse output
Read from timer	Count value can be read out by reading timer Ai register
Write to timer	<ul style="list-style-type: none"> <li>• When counting stopped When a value is written to timer Ai register, it is written to both reload register and counter</li> <li>• When counting in progress When a value is written to timer Ai register, it is written to only reload register (Transferred to counter at next reload time)</li> </ul>
Select function	<ul style="list-style-type: none"> <li>• Gate function Counting can be started and stopped by the TAiIN pin's input signal</li> <li>• Pulse output function Each time the timer underflows, the TAiOUT pin's polarity is reversed</li> </ul>

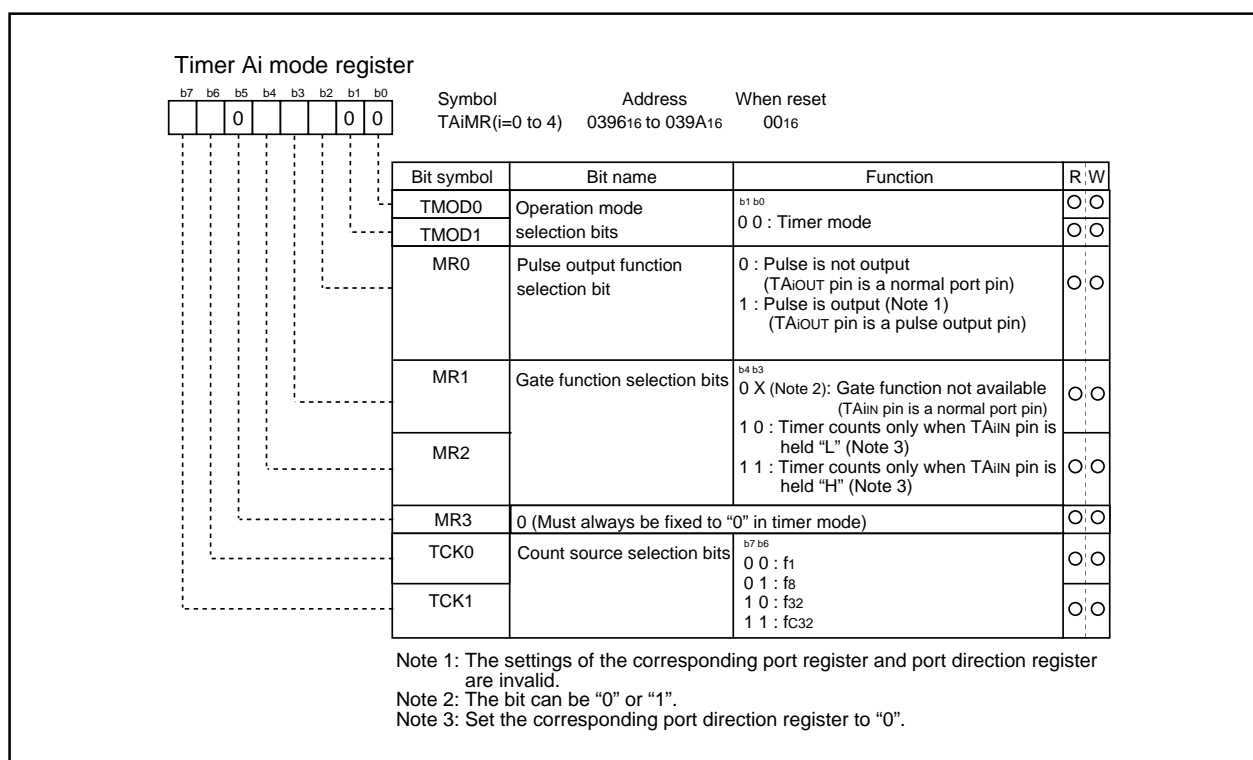
**Fig.FB-7 Timer Ai mode register in timer mode**



## (2) Event counter mode

In this mode, the timer counts an external signal or an internal timer's overflow. Timers A0 and A1 can count a single-phase external signal. Timers A2, A3, and A4 can count a single-phase and a two-phase external signals. Table.FB-2 lists timer specifications and Fig. FB-8 shows the timer Ai mode register in event count mode when counting a single-phase external signal.

Table.FB-3 lists timer specifications and Fig. FB-8 shows the timer Ai mode register in event count mode when counting a two-phase external signals.

**Table.FB-2 Timer specifications in event counter mode (when not processing two-phase pulse signal)**

Item	Specification
Count source	<ul style="list-style-type: none"> <li>External signal input to TAIIN pin (effective edge can be selected by software)</li> <li>TB2 overflow, TAJ overflow</li> </ul>
Count operation	<ul style="list-style-type: none"> <li>Up count or down count can be selected by external signal or software</li> <li>When the timer overflows or underflows, it reloads the reload register contents and then continuing counting (Note)</li> </ul>
Divide ratio	$1 / (FFFF_{16} - n + 1)$ for up count $1 / (n + 1)$ for down count                      n : Set value
Count start condition	Count start flag is set (= 1)
Count stop condition	Count start flag is reset (= 0)
Interrupt request generation timing	The timer overflows or underflows
TAiIN pin function	Programmable I/O port or count source input
TAiOUT pin function	Programmable I/O port, pulse output, or up/down count select input
Read from timer	Count value can be read out by reading timer Ai register
Write to timer	<ul style="list-style-type: none"> <li>When counting stopped When a value is written to timer Ai register, it is written to both reload register and counter</li> <li>When counting in progress When a value is written to timer Ai register, it is written to only reload register (Transferred to counter at next reload time)</li> </ul>
Select function	<ul style="list-style-type: none"> <li>Free-run count function Even when the timer overflows or underflows, the reload register content is not reloaded to it</li> <li>Pulse output function Each time the timer overflows or underflows, the TAIOUT pin's polarity is reversed</li> </ul>

Note: This does not apply when the free-run function is selected.

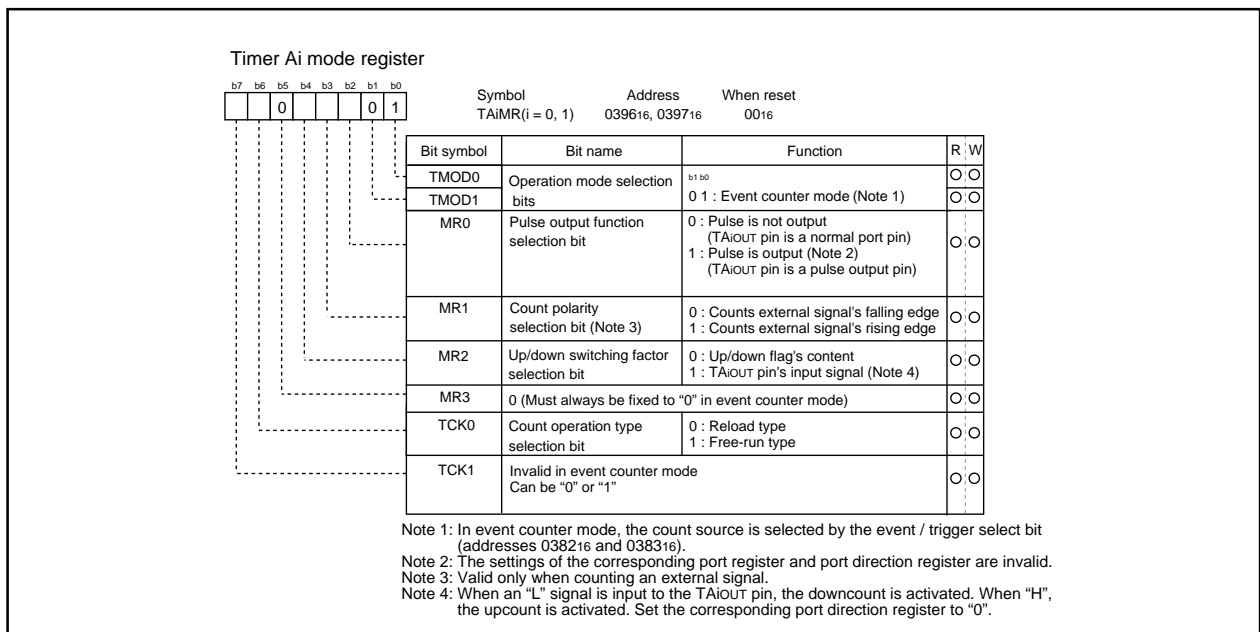
**Fig.FB-8 Timer Ai mode register in event counter mode**

**Table.FB-3** Timer specifications in event counter mode (when processing two-phase pulse signals with timers A2, A3, and A4)

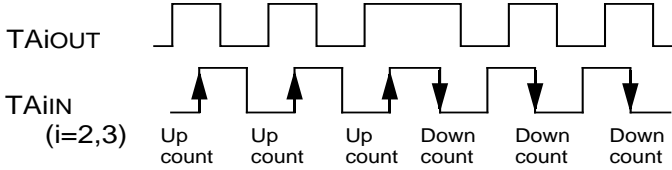
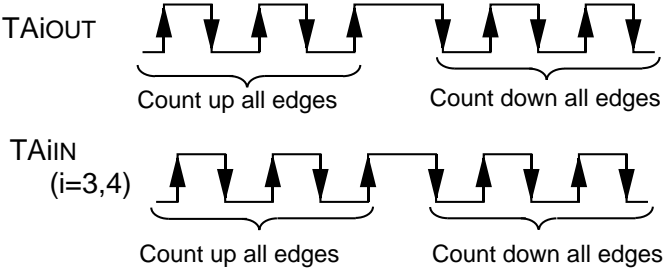
Item	Specification
Count source	<ul style="list-style-type: none"> <li>Two-phase pulse signals input to TAIiN and TAIiOUT pin</li> </ul>
Count operation	<ul style="list-style-type: none"> <li>Up count or down count can be selected by two-phase pulse signals</li> <li>When the timer overflows or underflows, the reload register content is reloaded and the timer starts over again (Note)</li> </ul>
Divide ratio	$1 / (FFFF_{16} - n + 1)$ for up count $1 / (n + 1)$ for down count      n : Set value
Count start condition	Count start flag is set (= 1)
Count stop condition	Count start flag is reset (= 0)
Interrupt request generation timing	Timer overflows or underflows
TAiIN pin function	Two-phase pulse input
TAiOUT pin function	Two-phase pulse input
Read from timer	Count value can be read out by reading timer A2, A3, or A4 register
Write to timer	<ul style="list-style-type: none"> <li>When counting stopped When a value is written to timer A2, A3, or A4 register, it is written to both reload register and counter</li> <li>When counting in progress When a value is written to timer A2, A3, or A4 register, it is written to only reload register. (Transferred to counter at next reload time.)</li> </ul>
Select function	<ul style="list-style-type: none"> <li>Normal processing operation The timer up-counts by the rising edge of TAIiN pin and down-counts by the falling edge fo TAIiN pin during the "H" level period of input signal in TAIiOUT pin.   </li> <li>Multiply-by-4 processing operation If the phase relationship is such that the TAIiN pin goes "H" when the input signal on the TAIiOUT pin is "H", the timer counts up rising and falling edges on the TAIiOUT and TAIiN pins. If the phase relationship is such that the TAIiN pin goes "L" when the input signal on the TAIiOUT pin is "H", the timer counts down rising and falling edges on the TAIiOUT and TAIiN pins.   </li> </ul>

Note: This does not apply when the free-run function is selected.

### Timer Ai mode register (When not using two-phase pulse signals' processing)

Symbol	Address	When reset
TAiMR(i = 2 to 4)	0398 <sub>16</sub> to 039A <sub>16</sub>	00 <sub>16</sub>

Bit symbol	Bit name	Function	R	W
TMOD0	Operation mode selection bits	b <sub>1</sub> b <sub>0</sub> 0 1 : Event counter mode	○	○
			○	○
MR0	Pulse output function selection bit	0 : Pulse is not output (TAiOUT pin is a normal port pin) 1 : Pulse is output (Note 1) (TAiOUT pin is a pulse output pin)	○	○
MR1	Count polarity selection bit (Note 2)	0 : Counts external signal's falling edges 1 : Counts external signal's rising edges	○	○
MR2	Up/down switching factor selection bit	0 : Up/down flag's content 1 : TAiOUT pin's input signal (Note 3)	○	○
MR3	0 : (Must always be "0" in event counter mode)		○	○
TCK0	Count operation type selection bit	0 : Reload type 1 : Free-run type	○	○
TCK1	Two-phase pulse signals' processing operation selection bit (Note 4)(Note 5)	0 : Normal processing operation 1 : Multiply-by-4 processing operation	○	○

Note 1: The settings of the corresponding port register and port direction register are invalid.

Note 2: This bit is valid when only counting an external signal.

Note 3: Set the corresponding port direction register to "0".

Note 4: This bit is valid for the timer A3 mode register.

For timer A2 and A4 mode registers, this bit can be "0" or "1".

Note 5: When performing two-phase signal processing, make sure the two-phase pulse signals' processing operation selection bit (address 0384<sub>16</sub>) is set to "1". Also, always be sure to set the event/trigger selection bit (addresses 0382<sub>16</sub> and 0383<sub>16</sub>) to "00".

### Timer Ai mode register (When using two-phase pulse signals' processing)

Symbol	Address	When reset
TAiMR(i = 2 to 4)	0398 <sub>16</sub> to 039A <sub>16</sub>	00 <sub>16</sub>

Bit symbol	Bit name	Function	R	W
TMOD0	Operation mode selection bits	b <sub>1</sub> b <sub>0</sub> 0 1 : Event counter mode	○	○
			○	○
MR0	0 (Must always be "0" when using two-phase pulse signal processing)		○	○
MR1	0 (Must always be "0" when using two-phase pulse signal processing)		○	○
MR2	1 (Must always be "1" when using two-phase pulse signal processing)		○	○
MR3	0 (Must always be "0" when using two-phase pulse signal processing)		○	○
TCK0	Count operation type selection bit	0 : Reload type 1 : Free-run type	○	○
TCK1	Two-phase pulse processing operation selection bit (Note 1)(Note 2)	0 : Normal processing operation 1 : Multiply-by-4 processing operation	○	○

Note 1: This bit is valid for timer A3 mode register.

For timer A2 and A4 mode registers, this bit can be "0" or "1".

Note 2: When performing two-phase pulse signals' processing, make sure the two-phase pulse signals' processing operation selection bit (address 0384<sub>16</sub>) is set to "1". Also, always be sure to set the event/trigger selection bit (addresses 0382<sub>16</sub> and 0383<sub>16</sub>) to "00".

Fig.FB-9 Timer Ai mode register in event counter mode

(3) One-shot timer mode

In this mode, the timer operates only once. (See Table.FB-4) When a trigger occurs, the timer starts to operate for a given period. Fig.FB-10 shows the timer Ai mode register in one-shot timer mode.

**Table.FB-4** Timer specifications in one-shot timer mode

Item	Specification
Count source	f1, f8, f32, fc32
Count operation	<ul style="list-style-type: none"> <li>The timer counts down</li> <li>When the count reaches 0000<sub>16</sub>, the timer stops counting after reloading a new count</li> <li>If a trigger occurs when counting, the timer reloads a new count and restarts counting</li> </ul>
Divide ratio	1/n    n : Set value
Count start condition	<ul style="list-style-type: none"> <li>An external trigger is input</li> <li>The timer overflows</li> <li>The one-shot start flag is set (= 1)</li> </ul>
Count stop condition	<ul style="list-style-type: none"> <li>A new count is reloaded after the count has reached 0000<sub>16</sub></li> <li>The count start flag is reset (= 0)</li> </ul>
Interrupt request generation timing	The count reaches 0000 <sub>16</sub>
TAiIN pin function	Programmable I/O port or trigger input
TAiOUT pin function	Programmable I/O port or pulse output
Read from timer	When timer Ai register is read, it indicates an indeterminate value
Write to timer	<ul style="list-style-type: none"> <li>When counting stopped When a value is written to timer Ai register, it is written to both reload register and counter</li> <li>When counting in progress When a value is written to timer Ai register, it is written to only reload register (Transferred to counter at next reload time)</li> </ul>

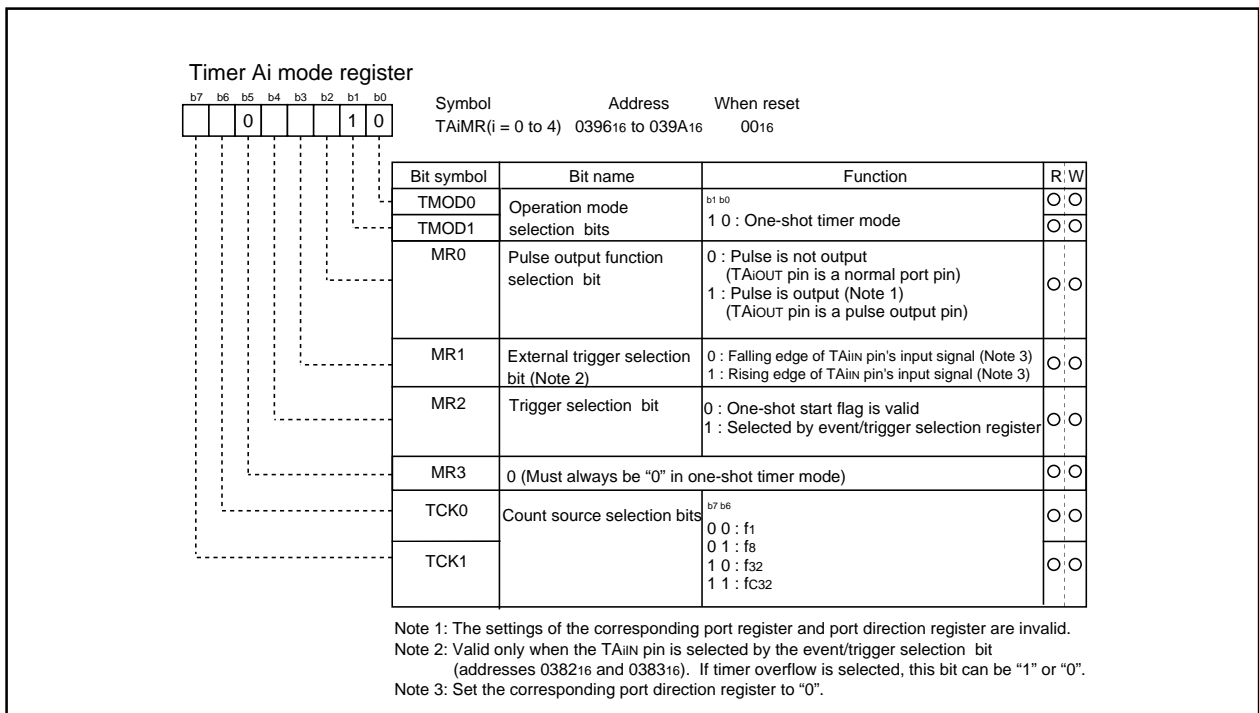

**Fig.FB-10** Timer Ai mode register in one-shot timer mode

## (4) Pulse width modulation (PWM) mode

In this mode, the timer outputs pulses of a given width in succession. (See Table.FB-5) In this mode, the counter functions as either a 16-bit pulse width modulator or an 8-bit pulse width modulator. Fig.FB-11 shows the timer Ai mode register in pulse width modulation mode. Fig.FB-12 shows the example of how a 16-bit pulse width modulator operates. Fig.FB-13 shows the example of how an 8-bit pulse width modulator operates.

**Table.FB-5 Timer specifications in pulse width modulation mode**

Item	Specification
Count source	f1, f8, f32, fC32
Count operation	<ul style="list-style-type: none"> <li>The timer counts down (operating as an 8-bit or a 16-bit pulse width modulator)</li> <li>The timer reloads a new count at a rising edge of PWM pulse and continues counting</li> <li>The timer is not affected by a trigger that occurs when counting</li> </ul>
16-bit PWM	<ul style="list-style-type: none"> <li>High level width <math>n / f_i</math> n : Set value</li> <li>Cycle time <math>(2^{16}-1) / f_i</math> fixed</li> </ul>
8-bit PWM	<ul style="list-style-type: none"> <li>High level width <math>n \times (m+1) / f_i</math> n : values set to timer Ai register's high-order address</li> <li>Cycle time <math>(2^8-1) \times (m+1) / f_i</math> m : values set to timer Ai register's low-order address</li> </ul>
Count start condition	<ul style="list-style-type: none"> <li>External trigger is input</li> <li>The timer overflows</li> <li>The count start flag is set (= 1)</li> </ul>
Count stop condition	<ul style="list-style-type: none"> <li>The count start flag is reset (= 0)</li> </ul>
Interrupt request generation timing	The falling edge of PWM pulse
TAiIN pin function	Programmable I/O port or trigger input
TAiOUT pin function	Pulse output
Read from timer	When timer Ai register is read, it indicates an indeterminate value
Write to timer	<ul style="list-style-type: none"> <li>When counting stopped When a value is written to timer Ai register, it is written to both reload register and counter</li> <li>When counting in progress When a value is written to timer Ai register, it is written to only reload register (Transferred to counter at next reload time)</li> </ul>

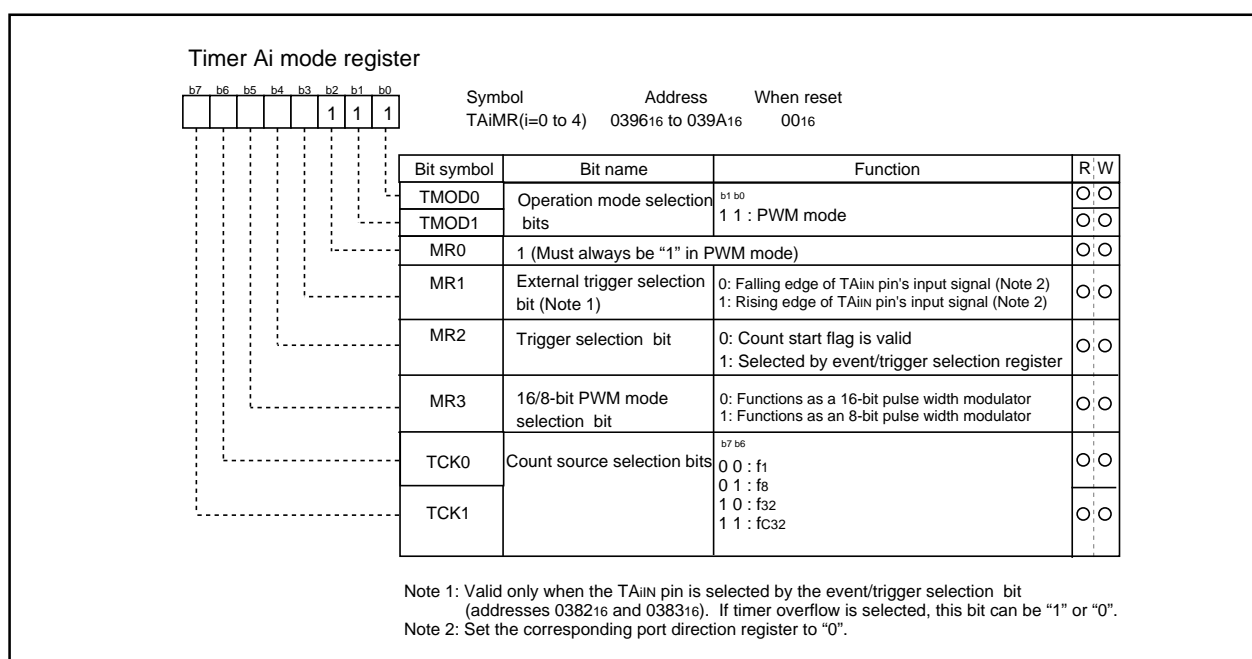
**Fig.FB-11 Timer Ai mode register in pulse width modulation mode**

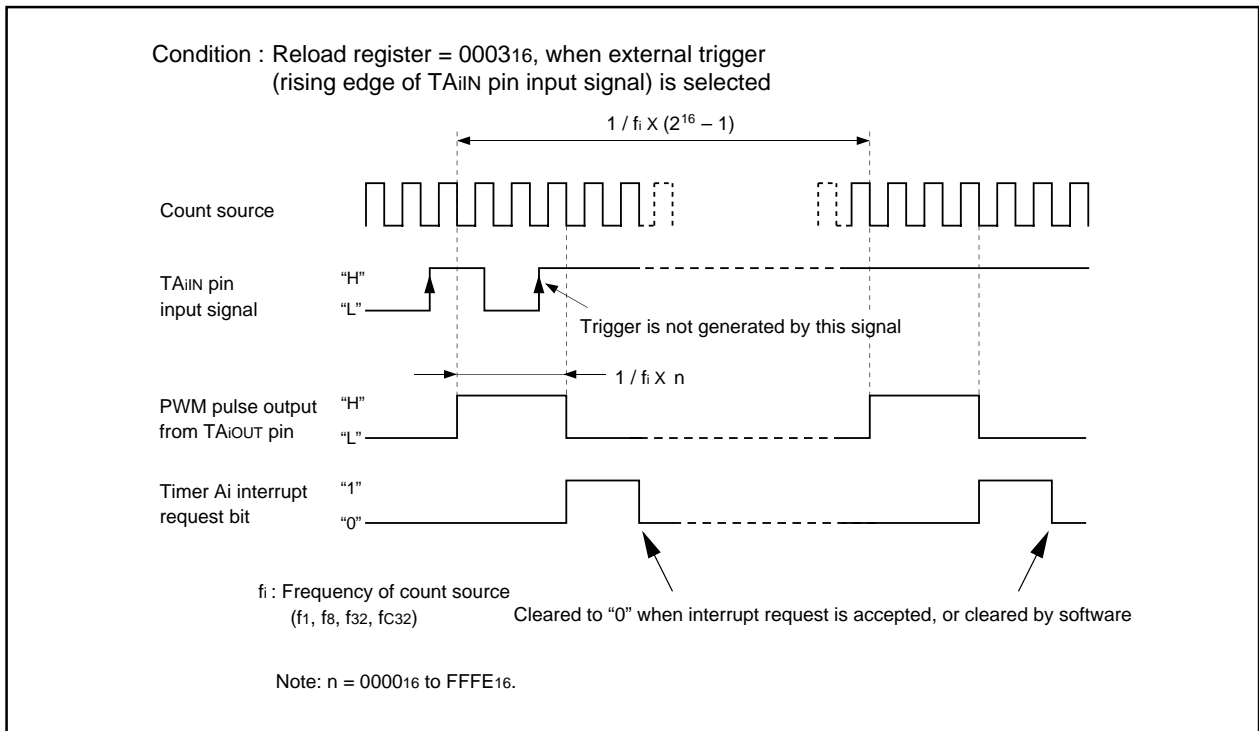

**Fig.FB-12 Example of how a 16-bit pulse width modulator operates**

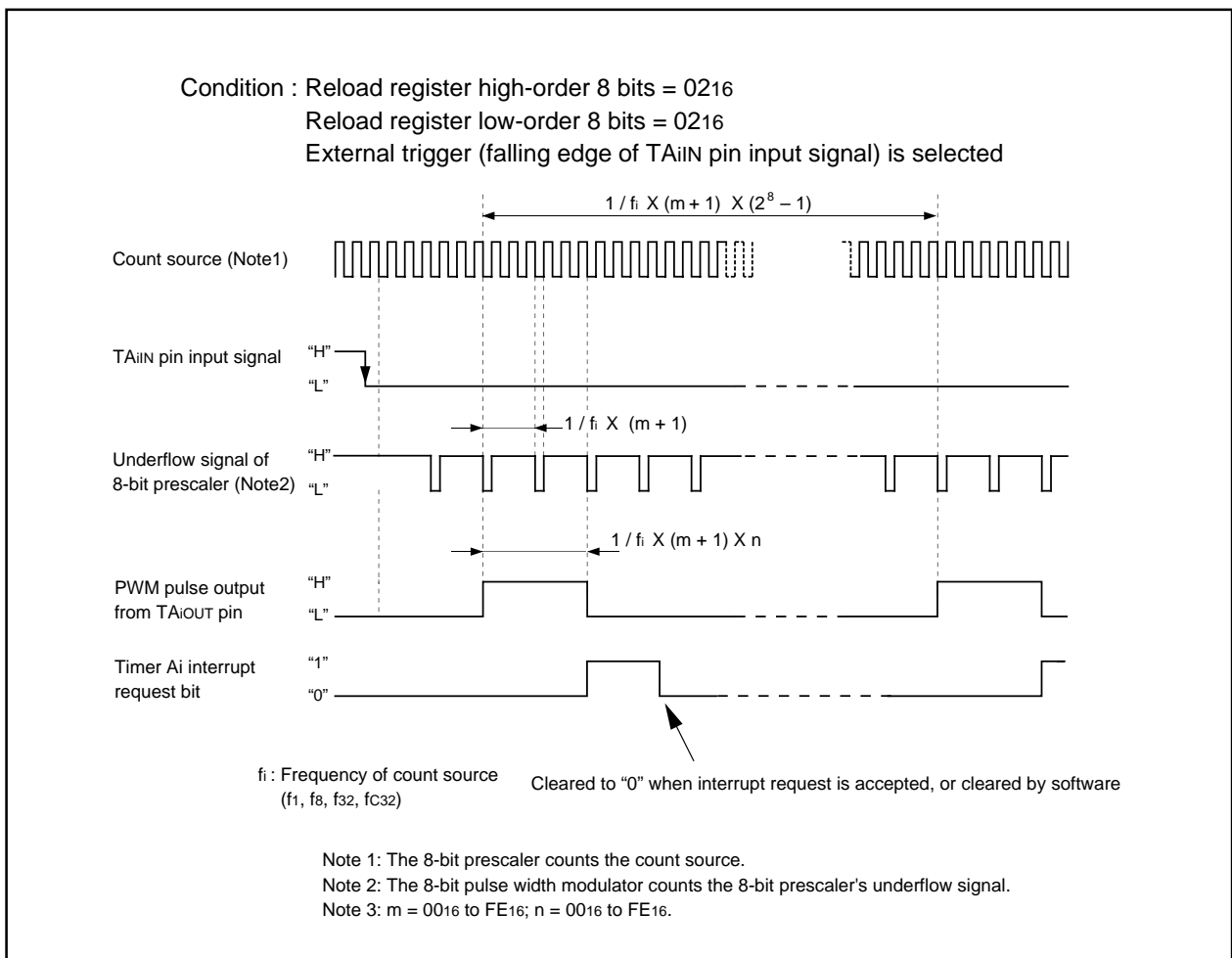

**Fig.FB-13 Example of how an 8-bit pulse width modulator operates**

### Timer B

Fig.FB-14 shows the block diagram of timer B. Fig.FB-15 and FB-16 show the timer B-related registers.

Use the timer Bi mode register (i = 0 to 5) bits 0 and 1 to choose the desired mode.

Timer B has three operation modes listed as follows:

- Timer mode: The timer counts an internal count source.
- Event counter mode: The timer counts pulses from an external source or a timer overflow.
- Pulse period/pulse width measuring mode: The timer measures an external signal's pulse period or pulse width.

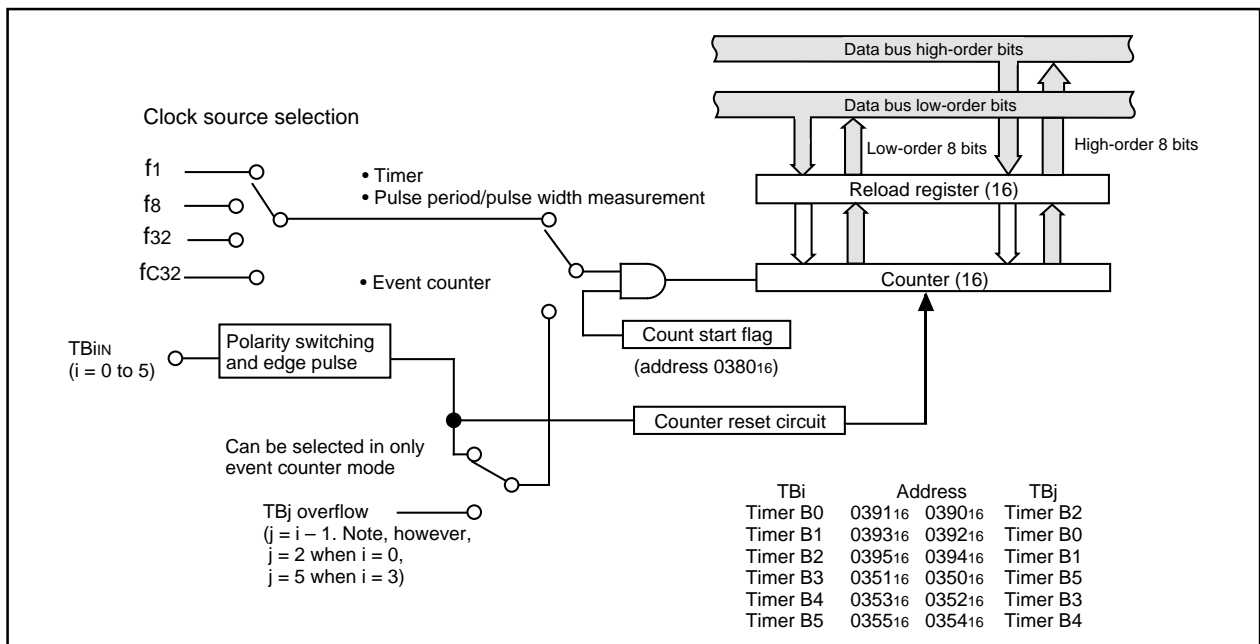

Fig.FB-14 Block diagram of timer B

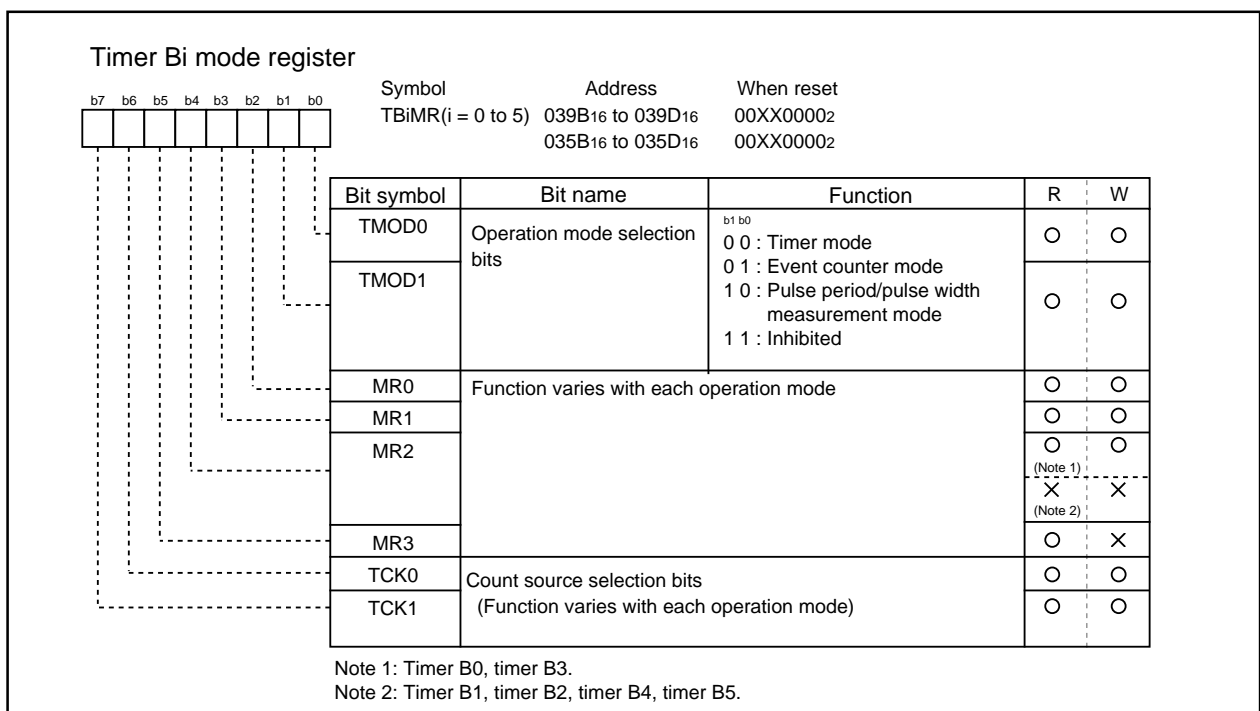

Fig.FB-15 Timer B-related registers (1)

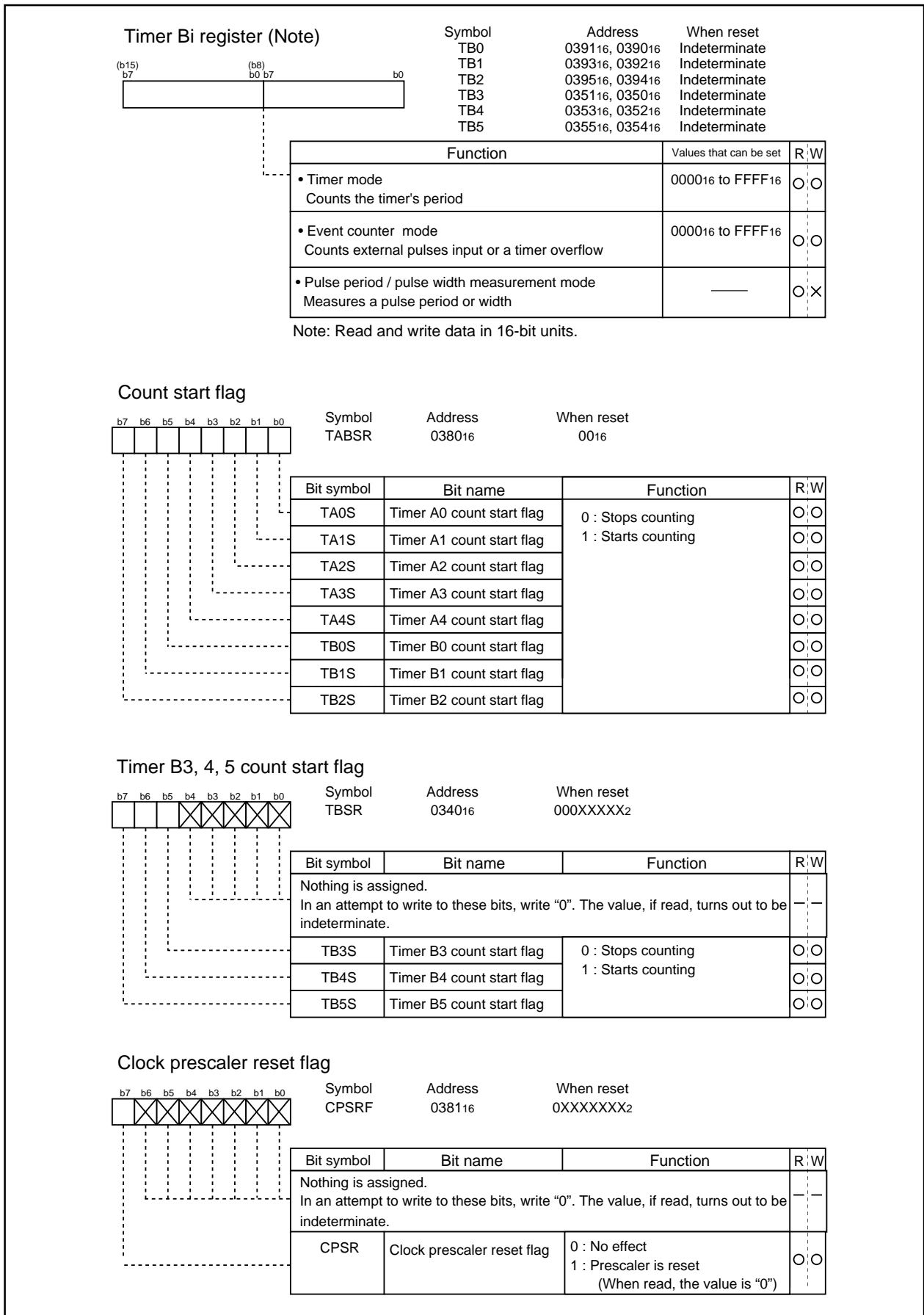

Fig.FB-16 Timer B-related registers (2)



**(1) Timer mode**

In this mode, the timer counts an internally generated count source. (See Table.FB-6.) Fig.FB-17 shows the timer Bi mode register in timer mode.

**Table.FB-6 Timer specifications in timer mode**

Item	Specification
Count source	f1, f8, f32, fC32
Count operation	<ul style="list-style-type: none"> <li>•Counts down</li> <li>•When the timer underflows, it reloads the reload register contents and then continuing counting</li> </ul>
Divide ratio	1/(n+1) n : Set value
Count start condition	Count start flag is set (= 1)
Count stop condition	Count start flag is reset (= 0)
Interrupt request generation timing	The timer underflows
TBiIN pin function	Programmable I/O port
Read from timer	Count value is read out by reading timer Bi register
Write to timer	<ul style="list-style-type: none"> <li>•When counting stopped</li> </ul> When a value is written to timer Bi register, it is written to both reload register and counter <ul style="list-style-type: none"> <li>• When counting in progress</li> </ul> When a value is written to timer Bi register, it is written to only reload register (Transferred to counter at next reload time)

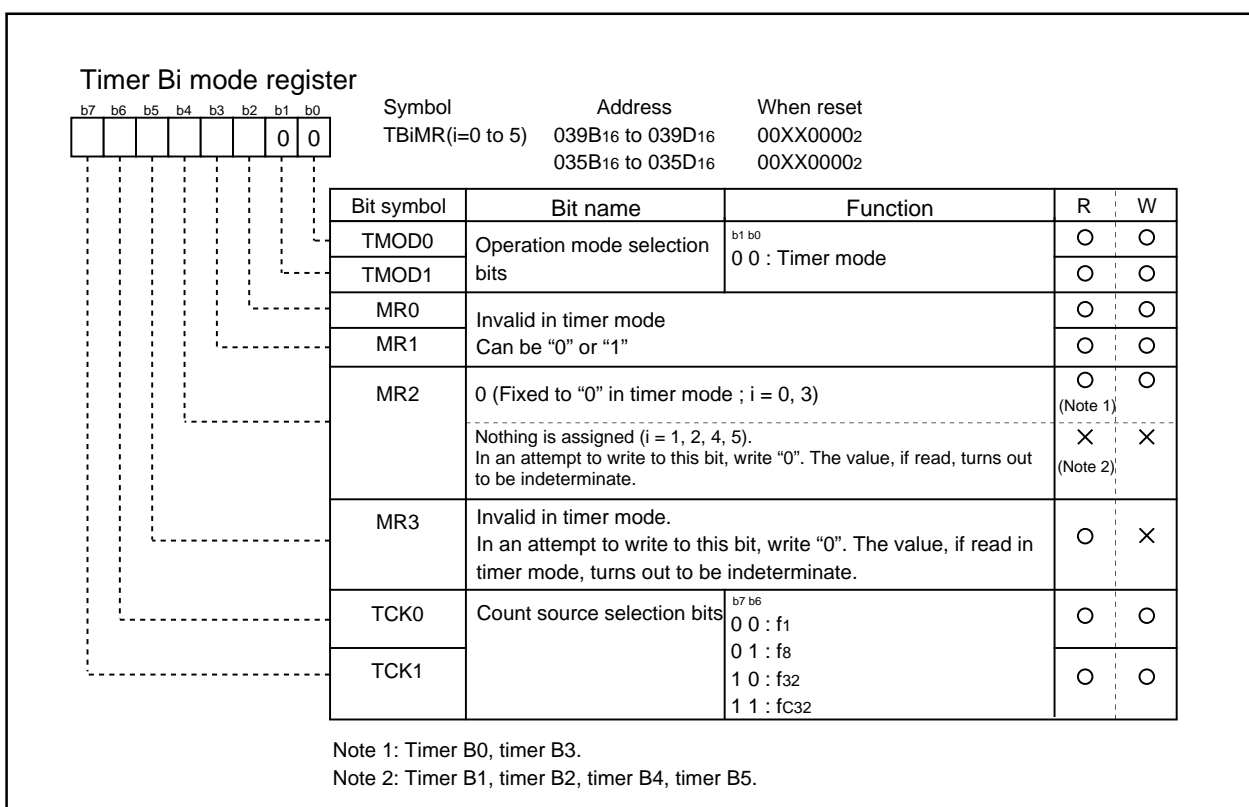
**Fig.FB-17 Timer Bi mode register in timer mode**

## (2) Event counter mode

In this mode, the timer counts an external signal or an internal timer's overflow. (See Table.FB-7) Fig.FB-18 shows the timer Bi mode register in event counter mode.

**Table.FB-7 Timer specifications in event counter mode**

Item	Specification
Count source	<ul style="list-style-type: none"> <li>External signals input to TBiIN pin</li> <li>Effective edge of count source can be a rising edge, a falling edge, or both edges as selected by software</li> </ul>
Count operation	<ul style="list-style-type: none"> <li>Counts down</li> <li>When the timer underflows, it reloads the reload register contents and then continuing counting</li> </ul>
Divide ratio	1/(n+1) n : Set value
Count start condition	Count start flag is set (= 1)
Count stop condition	Count start flag is reset (= 0)
Interrupt request generation timing	The timer underflows
TBiIN pin function	Count source input
Read from timer	Count value can be read out by reading timer Bi register
Write to timer	<ul style="list-style-type: none"> <li>When counting stopped When a value is written to timer Bi register, it is written to both reload register and counter</li> <li>When counting in progress When a value is written to timer Bi register, it is written to only reload register (Transferred to counter at next reload time)</li> </ul>

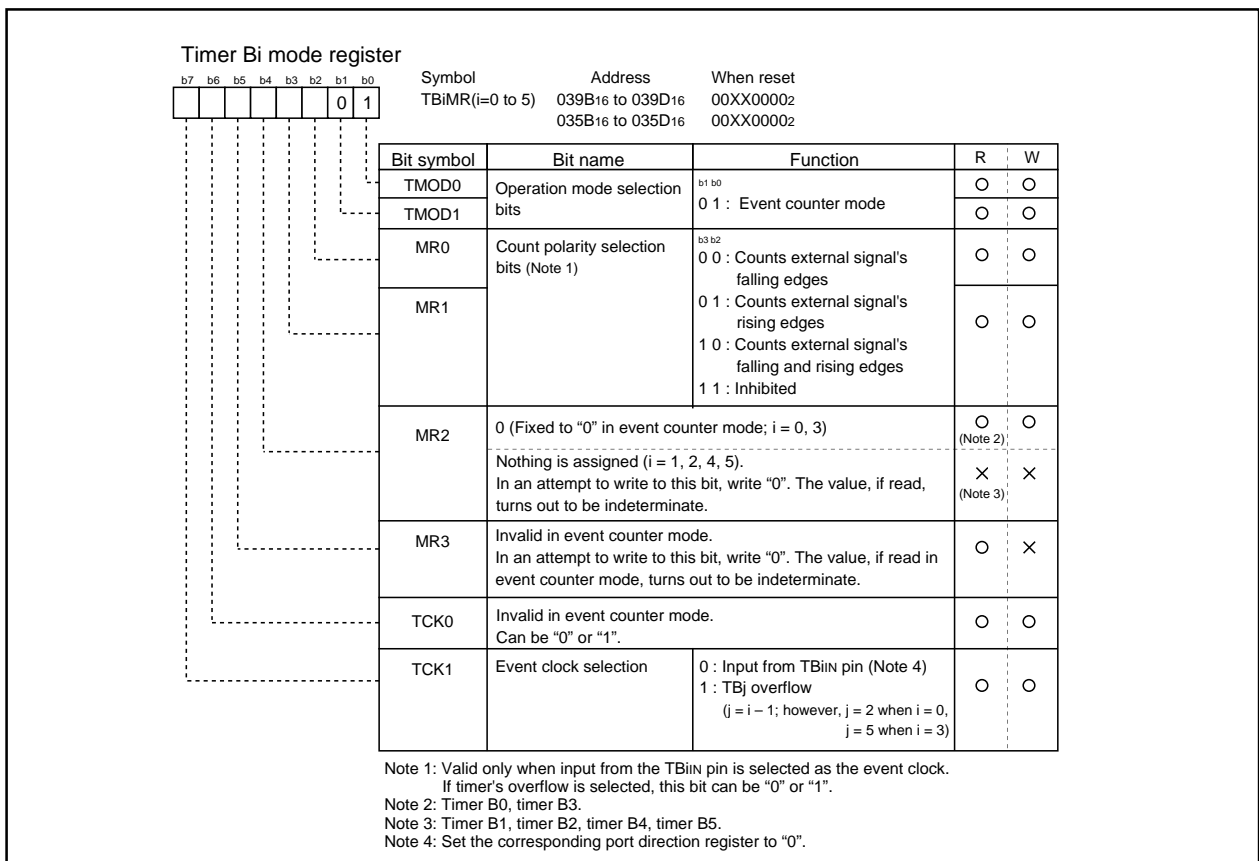
**Fig.FB-18 Timer Bi mode register in event counter mode**

### (3) Pulse period/pulse width measurement mode

In this mode, the timer measures the pulse period or pulse width of an external signal. (See Table.FB-8) Fig.FB-19 shows the timer Bi mode register in pulse period/pulse width measurement mode. Fig.FB-20 shows the operation timing when measuring a pulse period. Fig.FB-21 shows the operation timing when measuring a pulse width.

**Table.FB-8 Timer specifications in pulse period/pulse width measurement mode**

Item	Specification
Count source	f1, f8, f32, fc32
Count operation	<ul style="list-style-type: none"> <li>•Up count</li> <li>•At measurement pulse's effective edge, after the count value is transferred to reload register, it is cleared to "0000<sub>16</sub>" and then continues counting.</li> </ul>
Count start condition	Count start flag is set (= 1)
Count stop condition	Count start flag is reset (= 0)
Interrupt request generation timing	<ul style="list-style-type: none"> <li>•When measurement pulse's effective edge is input (Note 1)</li> <li>•When an overflow occurs. (Simultaneously, the timer Bi overflow flag becomes "1". The timer Bi overflow flag becomes "0" when the count start flag is "1" and a value is written to the timer Bi mode register.)</li> </ul>
TBiIn pin function	Measurement pulse input
Read from timer	When timer Bi register is read, it indicates the reload register's content (measurement result) (Note 2)
Write to timer	Cannot be written to

Note 1: An interrupt request is not generated when the first effective edge is input after the timer has started counting.

Note 2: After count starts, the value read out from the timer Bi register is indeterminate until the second effective edge is input .

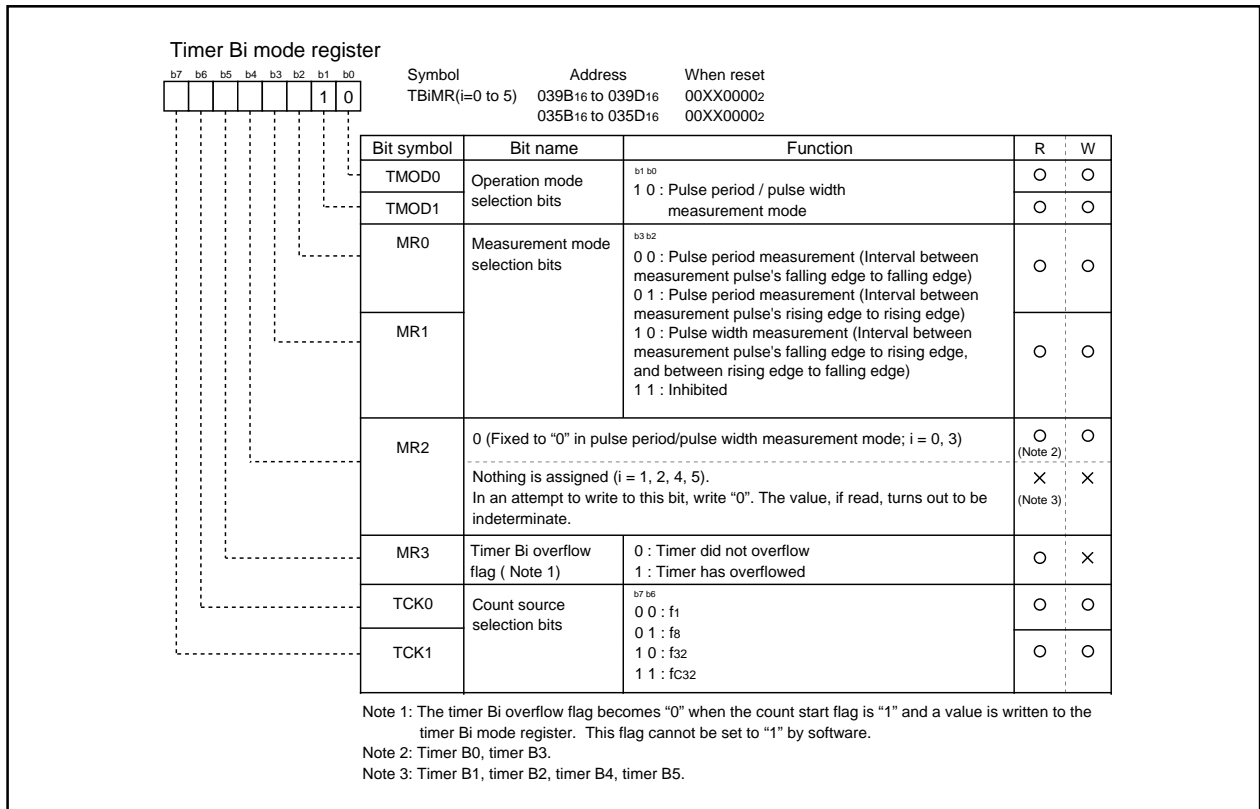

**Fig.FB-19 Timer Bi mode register in pulse period/pulse width measurement mode**

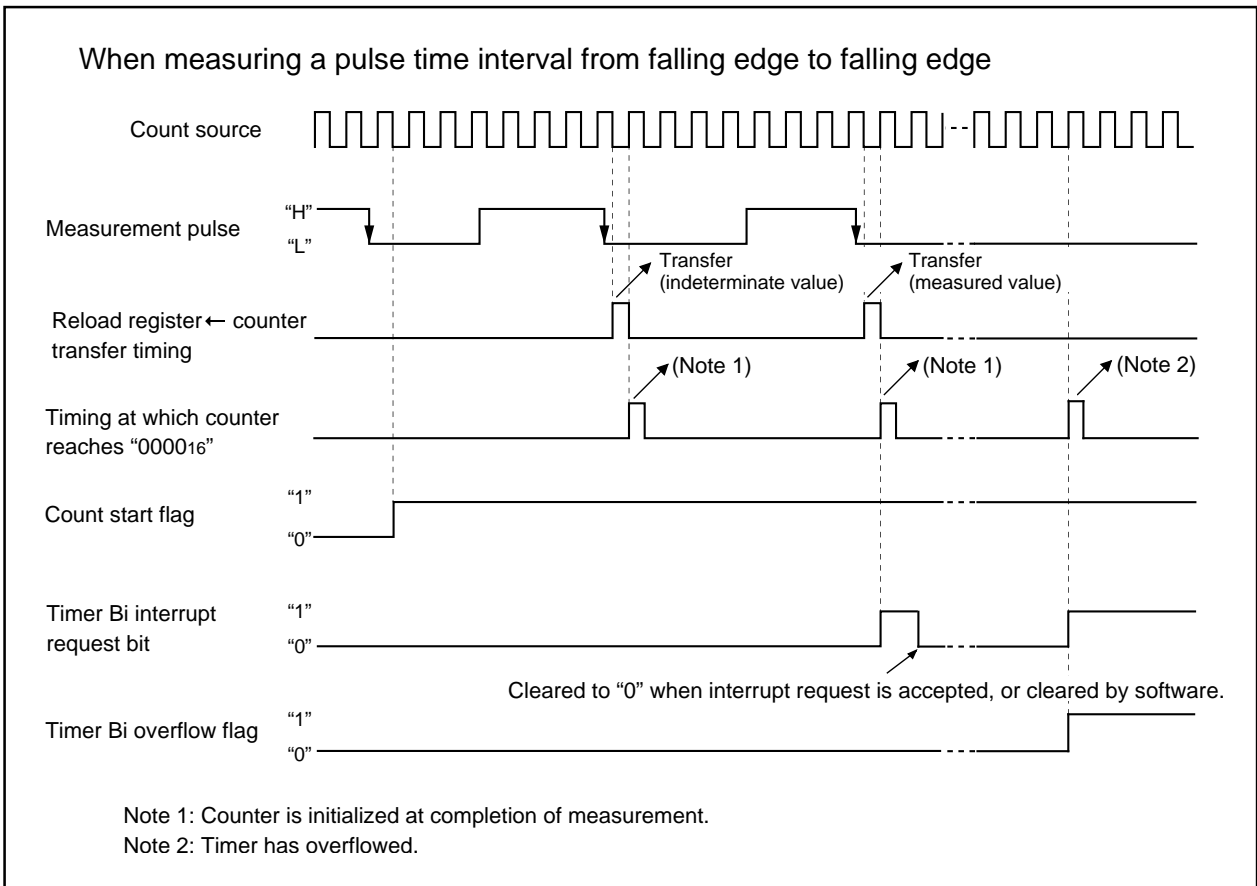

**Fig.FB-20 Operation timing when measuring a pulse period**

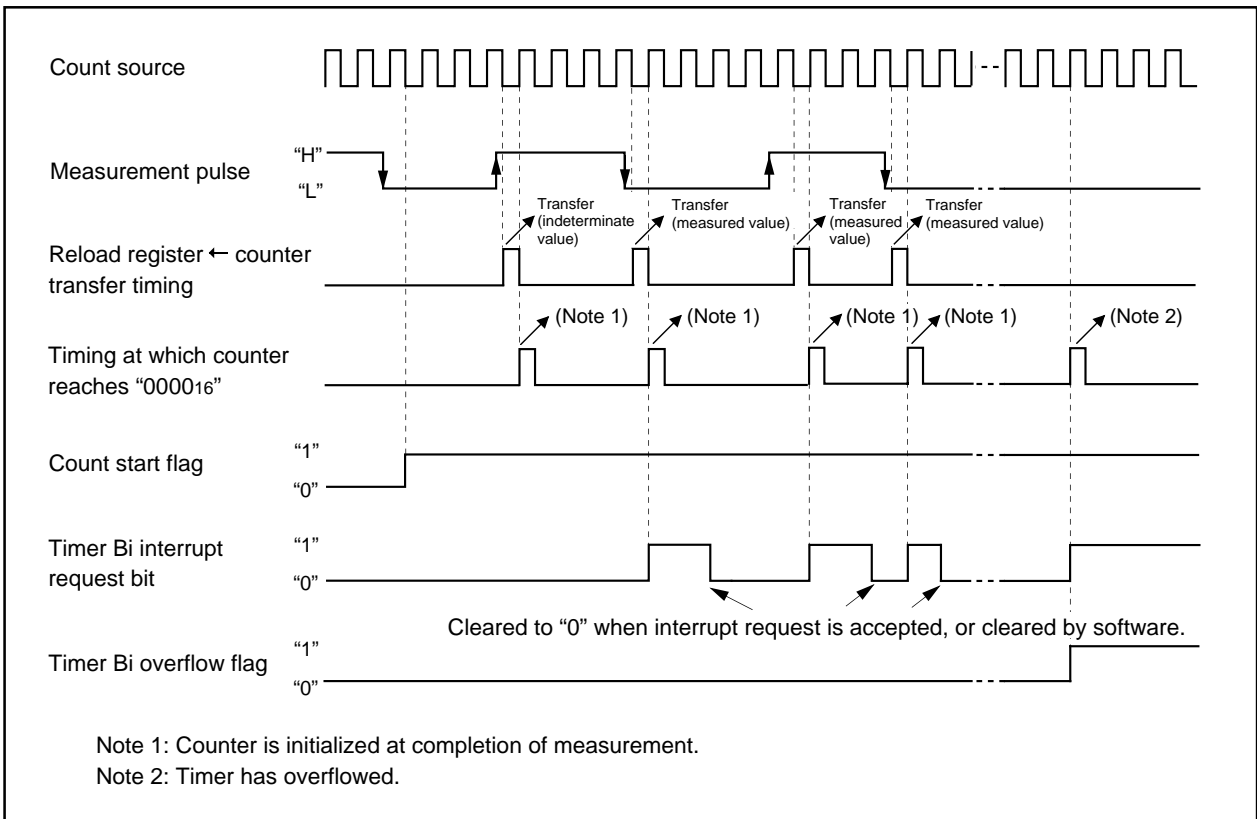

**Fig.FB-21 Operation timing when measuring a pulse width**

## Serial I/O

Serial I/O is configured as five channels: UART0, UART1, UART2, S I/O3 and S I/O4.

### UART0 to 2

Each of UART0 - UART2 has an exclusive timer to generate a transfer clock, operating independently from each other.

Fig.GA-1 shows the block diagram of UART0, UART1 and UART2. Fig.GA-2 and GA-3 show the block diagram of the transmit/receive unit.

UARTi (i = 0 to 2) has two operation modes: a clock synchronous serial I/O mode and a clock asynchronous serial I/O mode (UART mode). The contents of the serial I/O mode selection bits (bits 0 to 2 at addresses 03A0<sub>16</sub>, 03A8<sub>16</sub> and 0378<sub>16</sub>) determine whether UARTi is used as a clock synchronous serial I/O or as a UART. Although a few functions are different, UART0, UART1 and UART2 have almost the same functions. UART0 through UART2 are almost equal in their functions with minor exceptions. UART2, in particular, is compliant with the SIM interface with some extra settings added in clock-asynchronous serial I/O mode (Note). It also has the bus collision detection function that generates an interrupt request if the TxD pin and the RxD pin are different in level.

Table.GA-1 shows the comparison of functions of UART0 through UART2, and Fig.GA-4 to GA-8 show the registers related to UARTi.

Note: SIM : Subscriber Identity Module

**Table.GA-1 Comparison of functions of UART0 through UART2**

Function	UART0	UART1	UART2
CLK polarity selection	Possible (Note 1)	Possible (Note 1)	Possible (Note 1)
LSB first / MSB first selection	Possible (Note 1)	Possible (Note 1)	Possible (Note 2)
Continuous receive mode selection	Possible (Note 1)	Possible (Note 1)	Possible (Note 1)
Transfer clock output from multiple pins selection	Impossible	Possible (Note 1)	Impossible
Separate $\overline{\text{CTS}}$ / $\overline{\text{RTS}}$ pins	Possible	Impossible	Impossible
Serial data logic switch	Impossible	Impossible	Possible (Note 4)
Sleep mode selection	Possible (Note 3)	Possible (Note 3)	Impossible
TxD, RxD I/O polarity switch	Impossible	Impossible	Possible
TxD, RxD port output format	CMOS output	CMOS output	N-channel open-drain output
Parity error signal output	Impossible	Impossible	Possible (Note 4)
Bus collision detection	Impossible	Impossible	Possible

Note 1: Only in clock synchronous serial I/O mode.

Note 2: Only in clock synchronous serial I/O mode and 8-bit UART mode.

Note 3: Only in UART mode.

Note 4: Can be used for SIM interface.

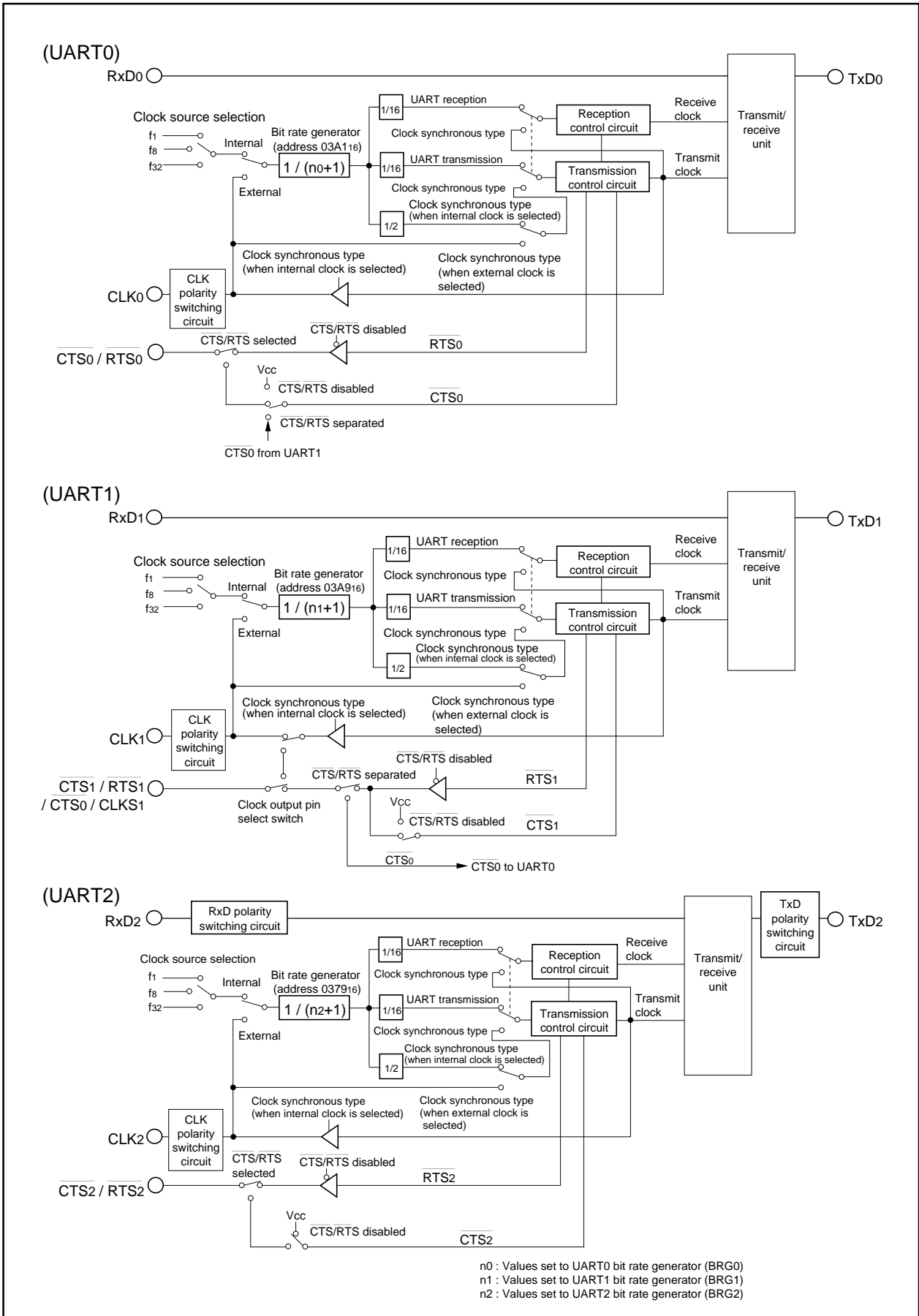

Fig.GA-1 Block diagram of UARTi (i = 0 to 2)

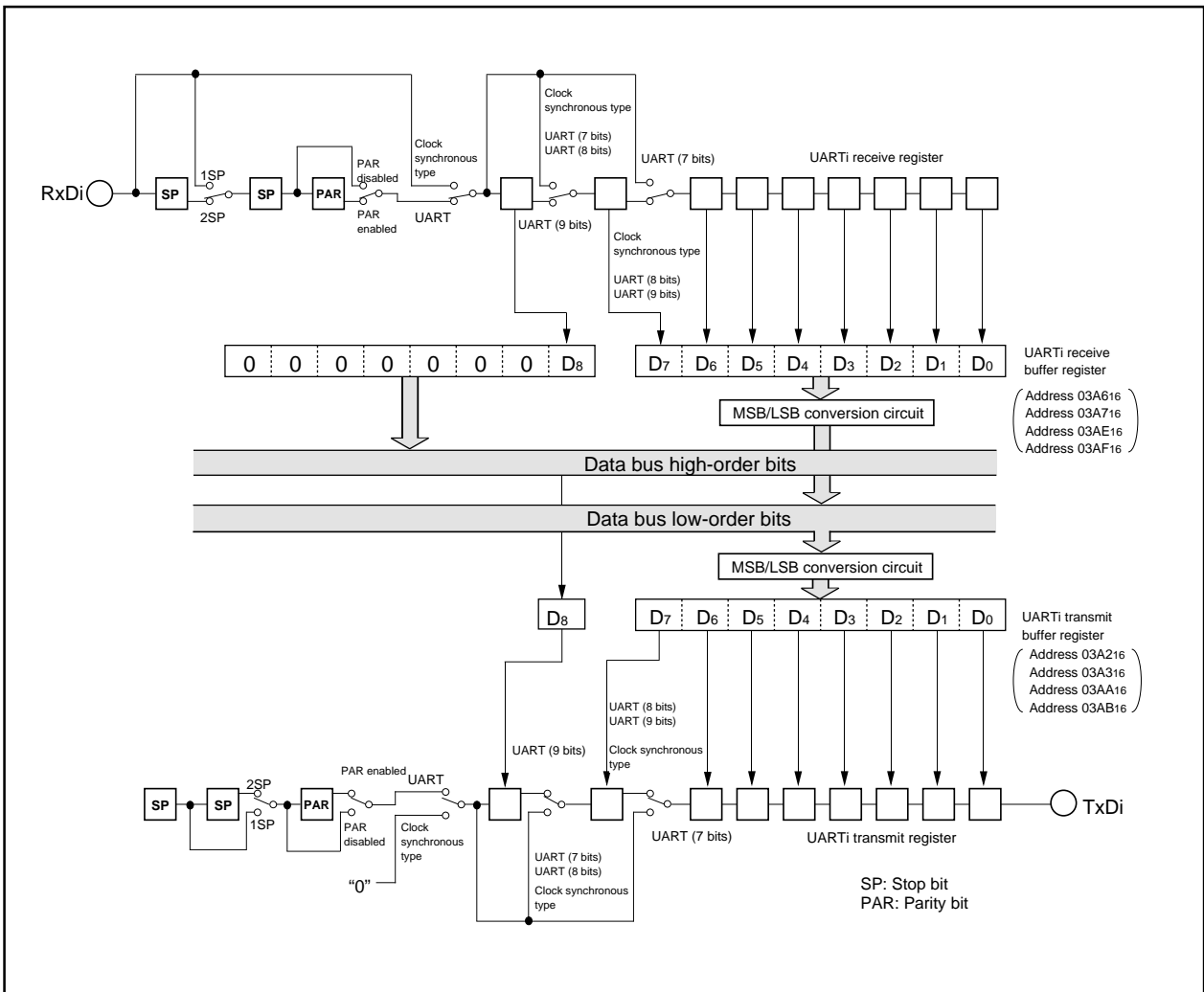

Fig.GA-2 Block diagram of UARTi (i = 0, 1) transmit/receive unit

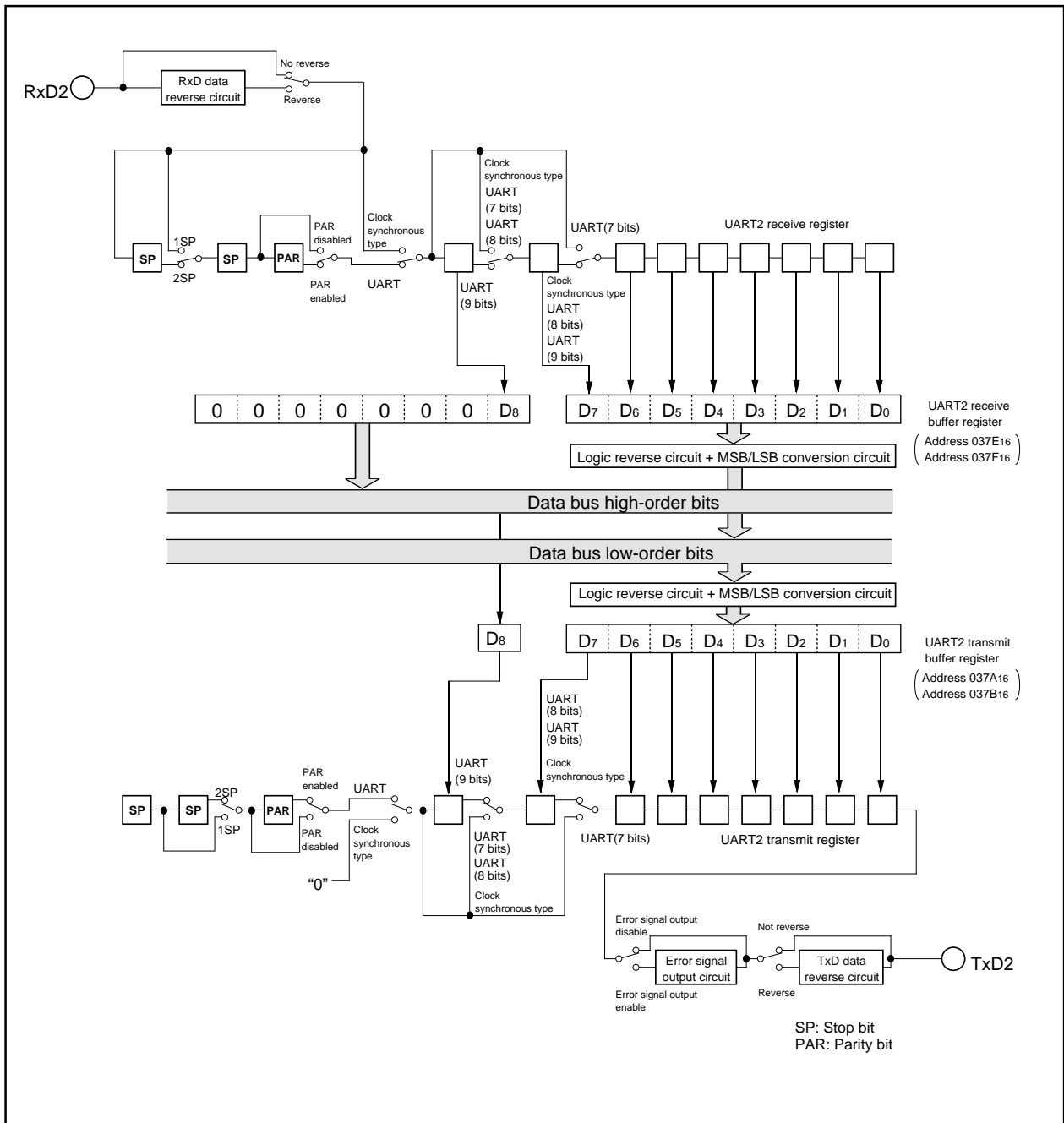

Fig.GA-3 Block diagram of UART2 transmit/receive unit



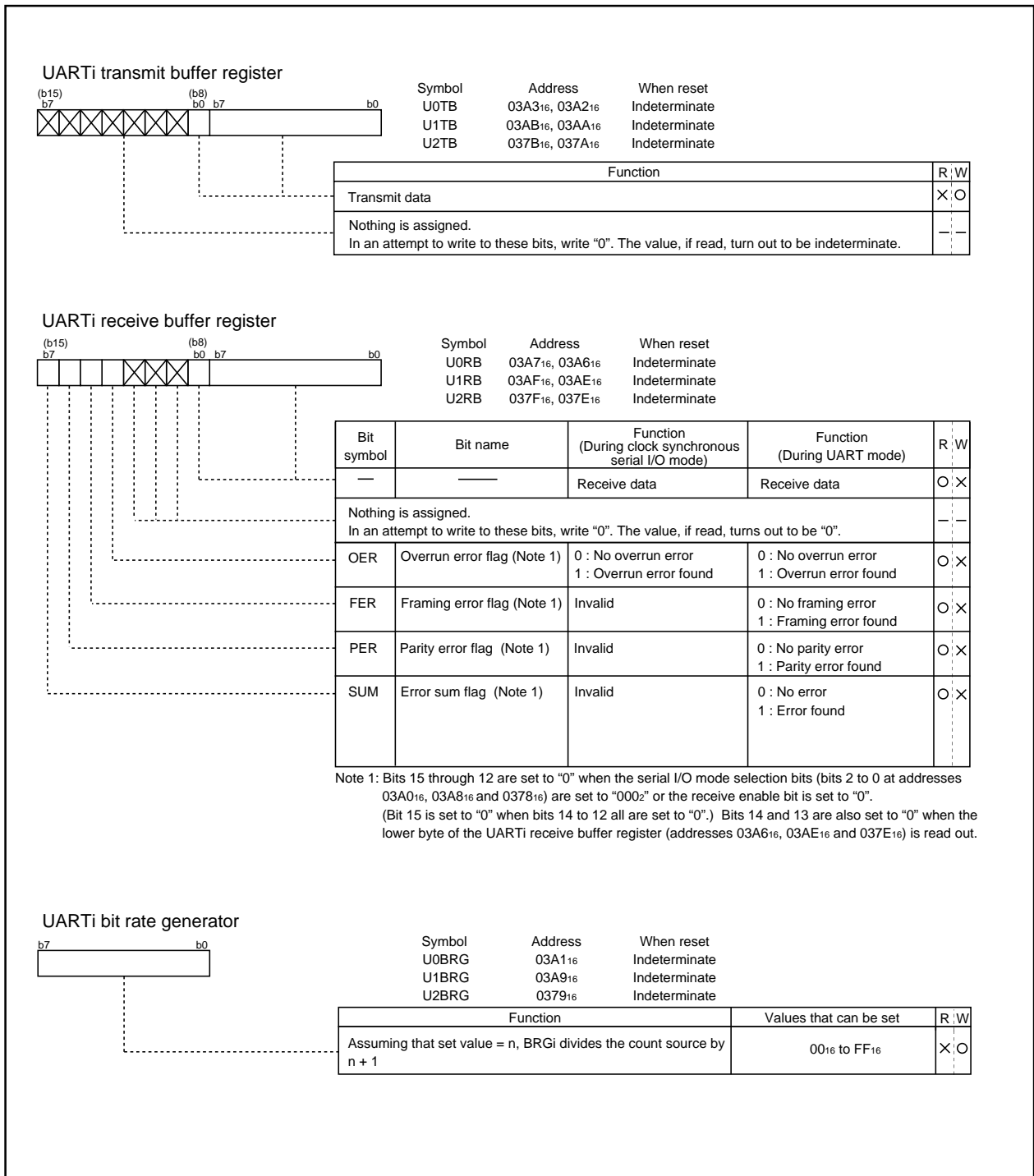

Fig.GA-4 Serial I/O-related registers (1)

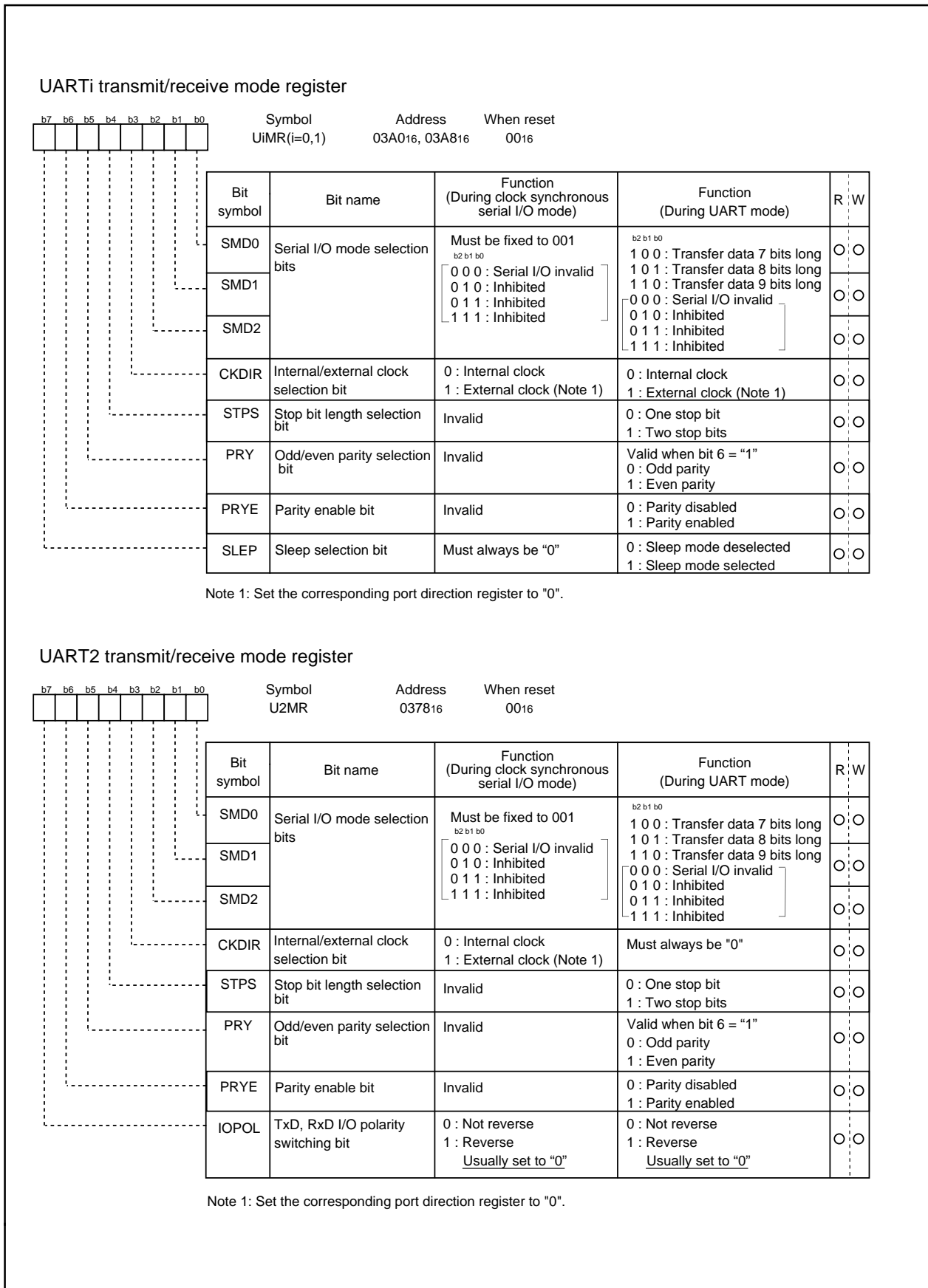

Fig.GA-5 Serial I/O-related registers (2)

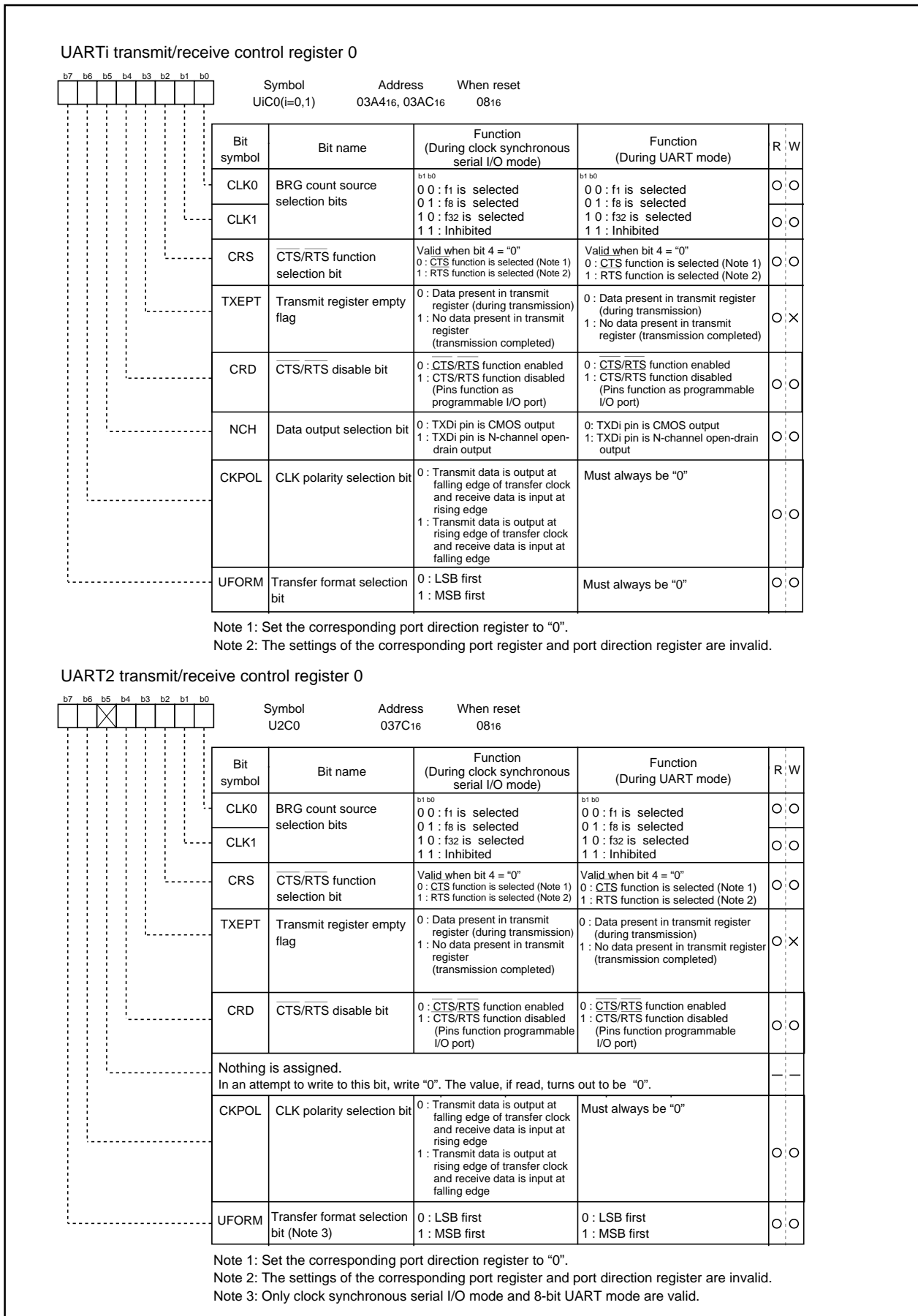

Fig.GA-6 Serial I/O-related registers (3)

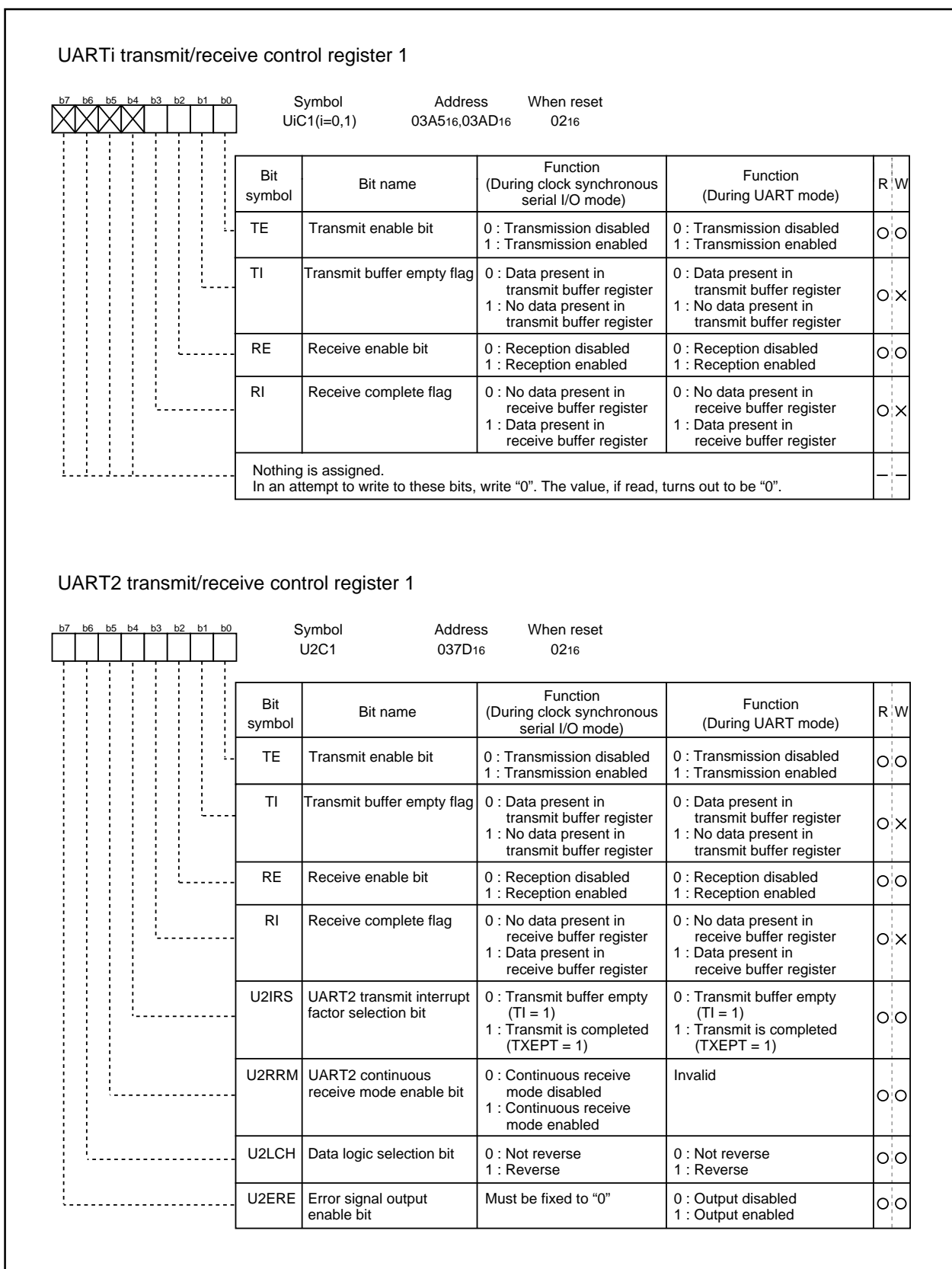

Fig.GA-7 Serial I/O-related registers (4)

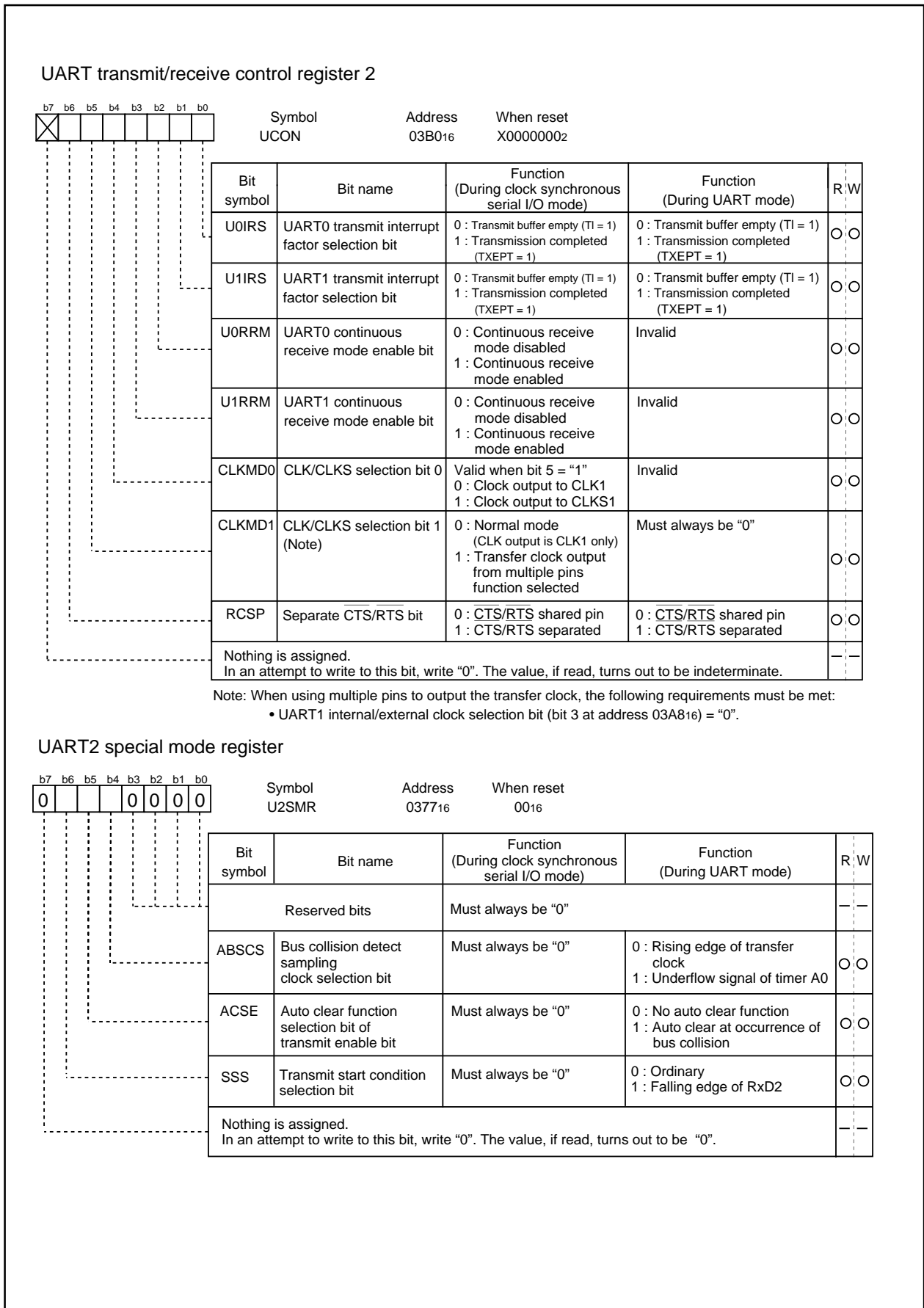

Fig.GA-8 Serial I/O-related registers (5)

**(1) Clock synchronous serial I/O mode**

The clock synchronous serial I/O mode uses a transfer clock to transmit and receive data. Tables.GA-2 and GA-3 list the specifications of the clock synchronous serial I/O mode. Fig.GA-9 shows the UART<sub>i</sub> transmit/receive mode register.

**Table.GA-2 Specifications of clock synchronous serial I/O mode (1)**

Item	Specification
Transfer data format	<ul style="list-style-type: none"> <li>Transfer data length: 8 bits</li> </ul>
Transfer clock	<ul style="list-style-type: none"> <li>When internal clock is selected (bit 3 at addresses 03A0<sub>16</sub>, 03A8<sub>16</sub>, 0378<sub>16</sub> = "0") : <math>f_i / 2(n+1)</math> (Note 1) <math>f_i = f_1, f_8, f_{32}</math></li> <li>When external clock is selected (bit 3 at addresses 03A0<sub>16</sub>, 03A8<sub>16</sub>, 0378<sub>16</sub> = "1") : Input from CLK<sub>i</sub> pin</li> </ul>
Transmission/reception control	<ul style="list-style-type: none"> <li>Selecting from <math>\overline{\text{CTS}}</math> function/RTS function/Disable <math>\overline{\text{CTS}}</math>, RTS function</li> </ul>
Transmission start condition	<ul style="list-style-type: none"> <li>To start transmission, the following requirements must be met: <ul style="list-style-type: none"> <li>Transmit enable bit (bit 0 at addresses 03A5<sub>16</sub>, 03AD<sub>16</sub>, 037D<sub>16</sub>) = "1"</li> <li>Transmit buffer empty flag (bit 1 at addresses 03A5<sub>16</sub>, 03AD<sub>16</sub>, 037D<sub>16</sub>) = "0"</li> <li>When <math>\overline{\text{CTS}}</math> function selected, <math>\overline{\text{CTS}}</math> input level = "L"</li> </ul> </li> <li>Furthermore, if external clock is selected, the following requirements must also be met: <ul style="list-style-type: none"> <li>CLK<sub>i</sub> polarity select bit (bit 6 at addresses 03A4<sub>16</sub>, 03AC<sub>16</sub>, 037C<sub>16</sub>) = "0": CLK<sub>i</sub> input level = "H"</li> <li>CLK<sub>i</sub> polarity select bit (bit 6 at addresses 03A4<sub>16</sub>, 03AC<sub>16</sub>, 037C<sub>16</sub>) = "1": CLK<sub>i</sub> input level = "L"</li> </ul> </li> </ul>
Reception start condition	<ul style="list-style-type: none"> <li>To start reception, the following requirements must be met: <ul style="list-style-type: none"> <li>Receive enable bit (bit 2 at addresses 03A5<sub>16</sub>, 03AD<sub>16</sub>, 037D<sub>16</sub>) = "1"</li> <li>Transmit enable bit (bit 0 at addresses 03A5<sub>16</sub>, 03AD<sub>16</sub>, 037D<sub>16</sub>) = "1"</li> <li>Transmit buffer empty flag (bit 1 at addresses 03A5<sub>16</sub>, 03AD<sub>16</sub>, 037D<sub>16</sub>) = "0"</li> </ul> </li> <li>Furthermore, if external clock is selected, the following requirements must also be met: <ul style="list-style-type: none"> <li>CLK<sub>i</sub> polarity select bit (bit 6 at addresses 03A4<sub>16</sub>, 03AC<sub>16</sub>, 037C<sub>16</sub>) = "0": CLK<sub>i</sub> input level = "H"</li> <li>CLK<sub>i</sub> polarity select bit (bit 6 at addresses 03A4<sub>16</sub>, 03AC<sub>16</sub>, 037C<sub>16</sub>) = "1": CLK<sub>i</sub> input level = "L"</li> </ul> </li> </ul>
Interrupt request generation timing	<ul style="list-style-type: none"> <li>When transmitting <ul style="list-style-type: none"> <li>Transmit interrupt factor selection bits (bits 0, 1 at address 03B0<sub>16</sub>, bit 4 at address 037D<sub>16</sub>) = "0": At the completion of data transmission from UART<sub>i</sub> transfer buffer register to UART<sub>i</sub> transmit register</li> <li>Transmit interrupt factor selection bits (bits 0, 1 at address 03B0<sub>16</sub>, bit 4 at address 037D<sub>16</sub>) = "1": At the completion of data transmission from UART<sub>i</sub> transfer register is completed</li> </ul> </li> <li>When receiving <ul style="list-style-type: none"> <li>At the completion of data transferring from UART<sub>i</sub> receive register to UART<sub>i</sub> receive buffer register</li> </ul> </li> </ul>
Error detection	<ul style="list-style-type: none"> <li>Overrun error (Note 2) This error occurs when the next data is ready before contents of UART<sub>i</sub> receive buffer register are read out</li> </ul>

Note 1: "n" denotes the value 00<sub>16</sub> to FF<sub>16</sub> that is set to the UART bit rate generator.

Note 2: If an overrun error occurs, the UART<sub>i</sub> receive buffer will have the next data written in. Note also that the UART<sub>i</sub> receive interrupt request bit is not set to "1".

**Table.GA-3 Specifications of clock synchronous serial I/O mode (2)**

Item	Specification
Function selection	<ul style="list-style-type: none"> <li>• CLK polarity selection Whether transmit data is output/input at the rising edge or falling edge of the transfer clock can be selected</li> <li>• LSB first/MSB first selection Whether transmission/reception begins with bit 0 or bit 7 can be selected</li> <li>• Continuous receive mode selection Reception is enabled simultaneously by a read from the receive buffer register</li> <li>• Transfer clock output from multiple pins selection (UART1) (Note) UART1 transfer clock can be chosen by software to be output from one of the two pins set</li> <li>• Separate <math>\overline{\text{CTS}}</math>/<math>\overline{\text{RTS}}</math> pins (UART0) (Note) Each of UART0 <math>\overline{\text{CTS}}</math> and <math>\overline{\text{RTS}}</math> pins can be assigned to separate pins</li> <li>• Switching serial data logic (UART2) Whether to reverse data in writing to the transmission buffer register or reading the reception buffer register can be selected.</li> <li>• TxD, RxD I/O polarity switching (UART2) This function is reversing TxD port output and RxD port input. All I/O data level is reversed.</li> </ul>

Note: The transfer clock output from multiple pins and the separate  $\overline{\text{CTS}}$ / $\overline{\text{RTS}}$  pins functions cannot be selected simultaneously.

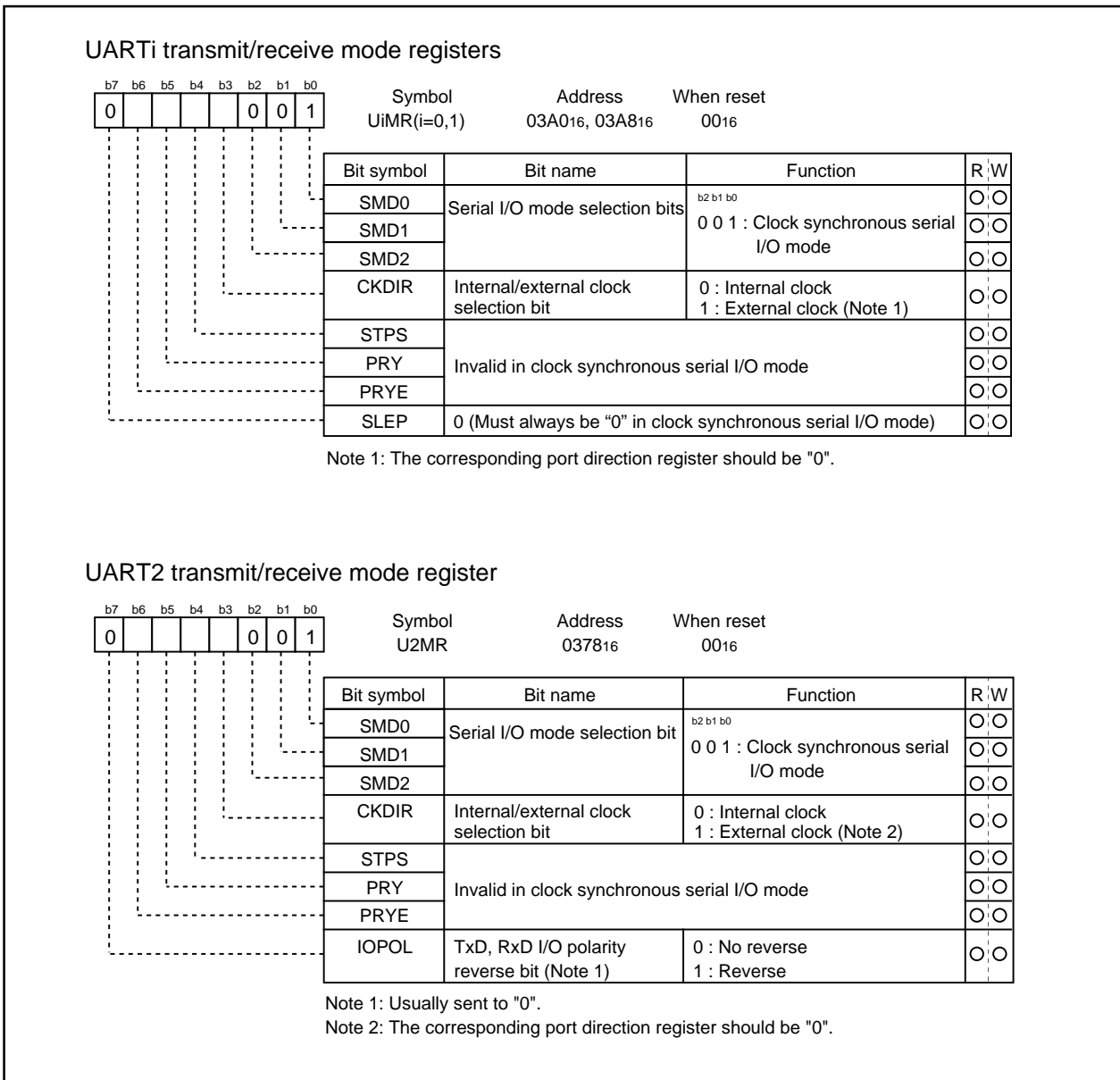

Fig.GA-9 UARTi transmit/receive mode register in clock synchronous serial I/O mode



Table.GA-4 lists the functions of the input/output pins during clock synchronous serial I/O mode. This table shows the pin functions that the transfer clock output from multiple pins and the separation of CTS/RTS pins are not selected. Note that for a period from when the UARTi operation mode is selected to when transfer starts, the TxDi pin outputs a "H". (If the N-channel open-drain is selected, this pin is in floating state.)

**Table.GA-4 Input/output pin functions in clock synchronous serial I/O mode**

(The function that the transfer clock output from multiple pin is not selected. The function that separates CTS/RTS pins is not selected.)

Pin name	Function	Method of selection
TxDi (P63,P67,P70)	Serial data output	(Outputs dummy data when performing reception only)
RxDi (P62,P66,P71)	Serial data input	Port P62, P66 and P71 direction register (bits 2 and 6 at address 03EE16, bit 1 at address 03EF16) = "0" (Can be used as an input port when performing transmission only)
CLKi (P61,P65,P72)	Transfer clock output	Internal/external clock select bit (bit 3 at address 03A016, 03A816, 037816) = "0"
	Transfer clock input	Internal/external clock select bit (bit 3 at address 03A016, 03A816, 037816) = "1" Port P61, P65 and P72 direction register (bits 1 and 5 at address 03EE16, bit 2 at address 03EF16) = "0"
CTS $\bar$ i/RTS $\bar$ i (P60,P64,P73)	CTS $\bar$ input	CTS/RTS disable bit (bit 4 at address 03A416, 03AC16, 037C16) = "0" CTS/RTS function selection bit (bit 2 at address 03A416, 03AC16, 037C16) = "0" The corresponding port direction bit = "0"
	RTS output	CTS/RTS disable bit (bit 4 at address 03A416, 03AC16, 037C16) = "0" CTS/RTS function selection bit (bit 2 at address 03A416, 03AC16, 037C16) = "1"
	Programmable I/O port	CTS/RTS disable bit (bit 4 at address 03A416, 03AC16, 037C16) = "1"

• Example of transmit timing (when internal clock is selected)

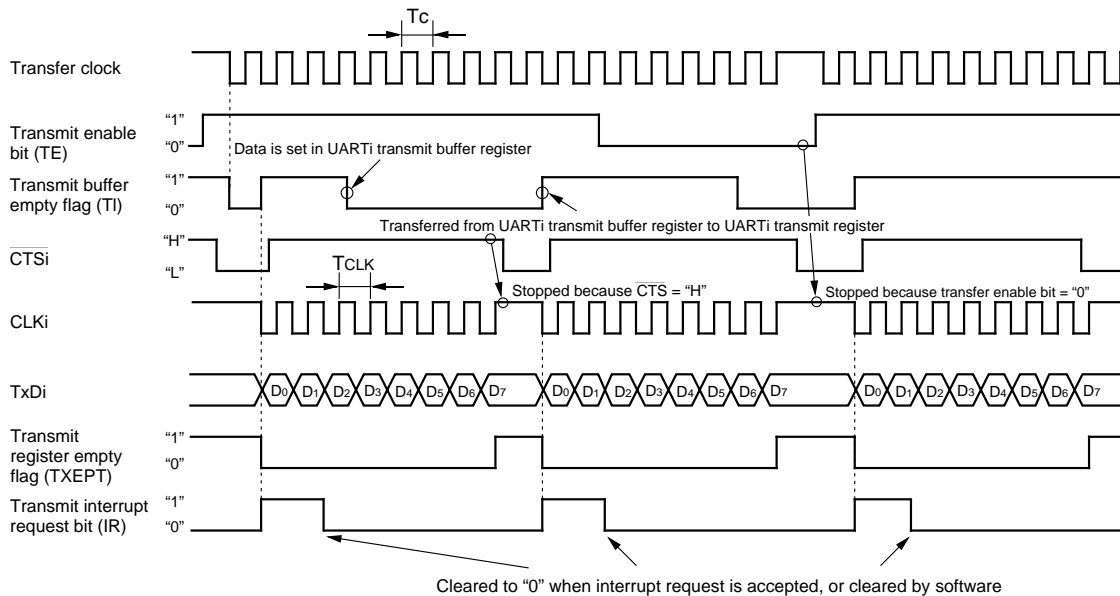

The above timing applies to the following settings:

- Internal clock is selected.
- CTS function is selected.
- CLK polarity selection bit = "0".
- Transmit interrupt factor selection bit = "0".

$$T_c = T_{CLK} = 2(n + 1) / f_i$$

$f_i$ : frequency of BRGi count source ( $f_1, f_8, f_{32}$ )  
 $n$ : value set to BRGi

• Example of receive timing (when external clock is selected)

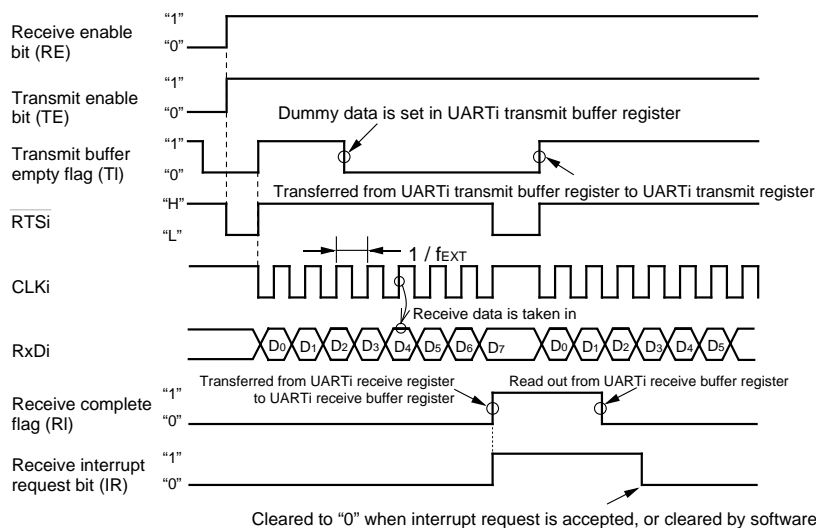

The above timing applies to the following settings:

- External clock is selected.
- RTS function is selected.
- CLK polarity selection bit = "0".

$f_{EXT}$ : frequency of external clock

The following conditions should be matched when the input level of CLKi pin is "H" before the data reception.

- Transmit enable bit → "1"
- Receive enable bit → "1"
- Dummy data write to UARTi transmit buffer register

Fig.GA-10 Typical transmit/receive timings in clock synchronous serial I/O mode

**(a) Polarity selection function**

As shown in Fig.GA-11, the CLK polarity selection bit (bit 6 at addresses 03A4<sub>16</sub>, 03AC<sub>16</sub>, 037C<sub>16</sub>) allows to select the polarity of the transfer clock.

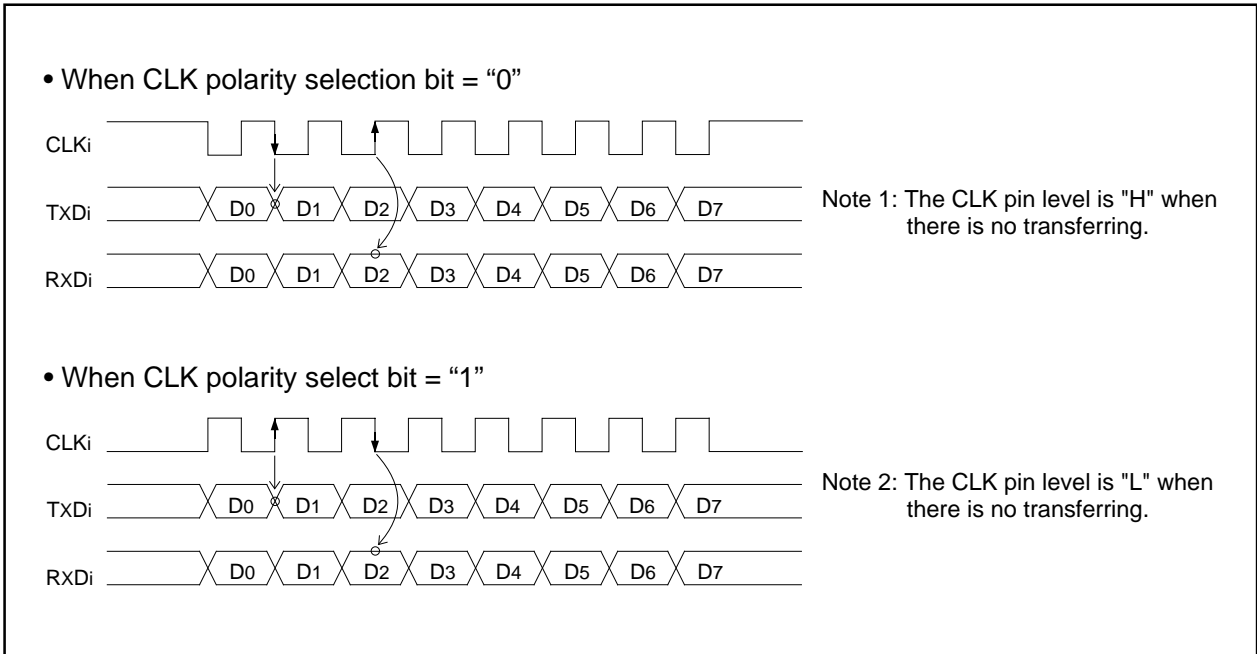

**Fig.GA-11 Polarity of transfer clock**

**(b) LSB first/MSB first selection function**

As shown in Fig.GA-12, when the transfer format selection bit (bit 7 at addresses 03A4<sub>16</sub>, 03AC<sub>16</sub>, 037C<sub>16</sub>) = "0", the transfer format is "LSB first"; when the bit = "1", the transfer format is "MSB first".

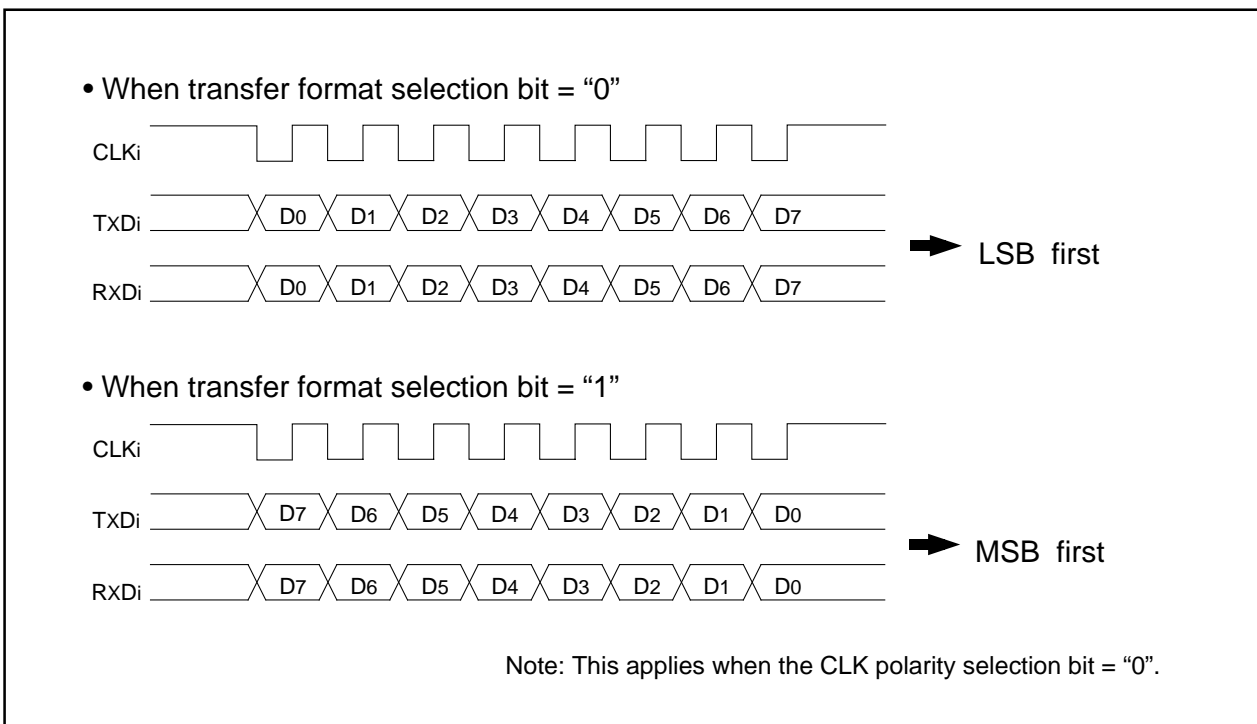
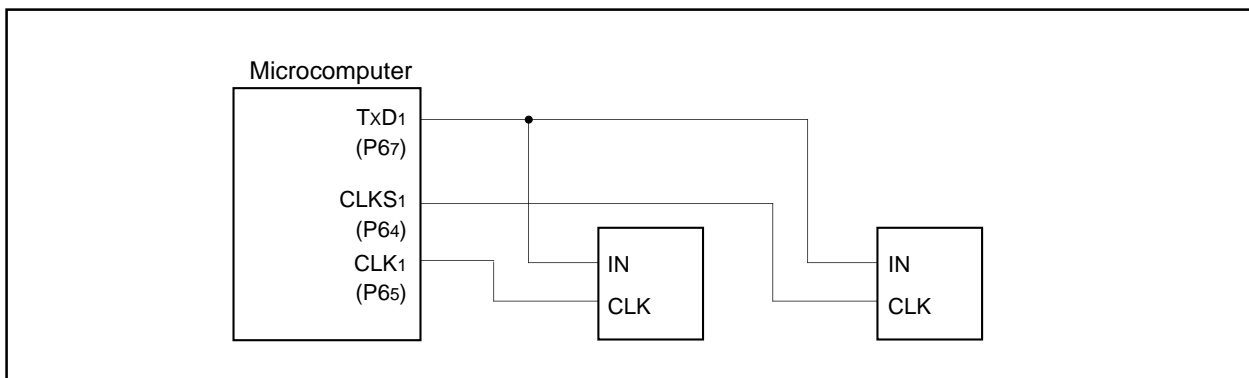

**Fig.GA-12 Transfer format**

## Clock synchronous serial I/O mode

**(c) Transfer clock output from multiple pins function (UART1)**

This function allows to set two transfer clock output pins and chooses one to output a clock by the setting of CLK and CLKS selection bits (bits 4 and 5 at address 03B016). (See Fig.GA-13) The function is valid only when the UART1 internal clock is selected. Note that when this function is selected, UART1  $\overline{\text{CTS}}/\overline{\text{RTS}}$  function cannot be used.



**Fig.GA-13** The sample of transfer clock output from the multiple pins function

**(d) Continuous receive mode**

If the continuous receive mode enable bits (bits 2 and 3 at address 03B016, bit 5 at address 037D16) are set to "1", the unit is placed in continuous receive mode. In this mode, when the receive buffer register is read out, the unit simultaneously goes to a receive enable state without having to set dummy data to the transmit buffer register back again.

**(e) Separate  $\overline{\text{CTS}}/\overline{\text{RTS}}$  pins function (UART0)**

This function works the same way as in the clock asynchronous serial I/O (UART) mode. The method of setting and the input/output pin functions are both the same, so refer to the selection function in the next section, "(2) Clock asynchronous serial I/O (UART) mode." Note that this function is invalid if the transfer clock output from the multiple pins function is selected.

**(f) Serial data logic switch function (UART2)**

When the data logic selection bit (bit6 at address 037D16) = "1", the data writing to transmit buffer register or reading from receive buffer register, are reversed. Fig.GA-14 shows the example of serial data logic switch timing.

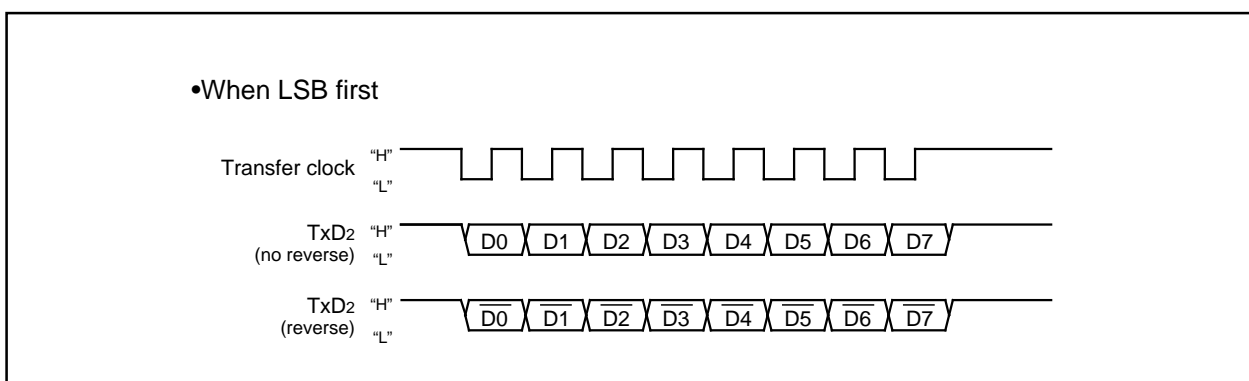

**Fig.GA-14** Serial data logic switch timing

## Clock asynchronous serial I/O (UART) mode

**(2) Clock asynchronous serial I/O (UART) mode**

The UART mode allows transmitting and receiving data after setting the desired transfer rate and transfer data format. Tables.GA-5 and GA-6 list the specifications of the UART mode. Fig.GA-15 shows the UARTi transmit/receive mode register.

**Table.GA-5 Specifications of UART Mode (1)**

Item	Specification
Transfer data format	<ul style="list-style-type: none"> <li>• Character bit (transfer data): 7 bits, 8 bits, or 9 bits as selected</li> <li>• Start bit: 1 bit</li> <li>• Parity bit: Odd, even, or nothing as selected</li> <li>• Stop bit: 1 bit or 2 bits as selected</li> </ul>
Transfer clock	<ul style="list-style-type: none"> <li>• When internal clock is selected (bit 3 at addresses 03A0<sub>16</sub>, 03A8<sub>16</sub>, 0378<sub>16</sub> = "0") : f<sub>i</sub>/16(n+1) (Note 1) f<sub>i</sub> = f<sub>1</sub>, f<sub>8</sub>, f<sub>32</sub></li> <li>• When external clock is selected (bit 3 at addresses 03A0<sub>16</sub>, 03A8<sub>16</sub> = "1") : f<sub>EXT</sub>/16(n+1)(Note 1) (Note 2)</li> <li>• Do not select the external clock in UART2.</li> </ul>
Transmission/reception control	<ul style="list-style-type: none"> <li>• Selecting from <math>\overline{\text{CTS}}</math> function/ <math>\overline{\text{RTS}}</math> function/ Disable <math>\overline{\text{CTS}}</math>, <math>\overline{\text{RTS}}</math> function</li> </ul>
Transmission start condition	<ul style="list-style-type: none"> <li>• To start transmission, the following requirements must be met: <ul style="list-style-type: none"> <li>- Transmit enable bit (bit 0 at addresses 03A5<sub>16</sub>, 03AD<sub>16</sub>, 037D<sub>16</sub>) = "1"</li> <li>- Transmit buffer empty flag (bit 1 at addresses 03A5<sub>16</sub>, 03AD<sub>16</sub>, 037D<sub>16</sub>) = "0"</li> <li>- When <math>\overline{\text{CTS}}</math> function is selected <math>\overline{\text{CTS}}</math> input level = "L"</li> </ul> </li> </ul>
Reception start condition	<ul style="list-style-type: none"> <li>• To start reception, the following requirements must be met: <ul style="list-style-type: none"> <li>- Receive enable bit (bit 2 at addresses 03A5<sub>16</sub>, 03AD<sub>16</sub>, 037D<sub>16</sub>) = "1"</li> <li>- Start bit detection</li> </ul> </li> </ul>
Interrupt request generation timing	<ul style="list-style-type: none"> <li>• When transmitting <ul style="list-style-type: none"> <li>- Transmit interrupt factor selection bits (bits 0,1 at address 03B0<sub>16</sub>, bit4 at address 037D<sub>16</sub>) = "0": At the completion of data transferring from UARTi transfer buffer register to UARTi transmit register</li> <li>- Transmit interrupt factor selection bits (bits 0, 1 at address 03B0<sub>16</sub>, bit4 at address 037D<sub>16</sub>) = "1": At the completion of data transmission from UARTi transfer register</li> </ul> </li> <li>• When receiving <ul style="list-style-type: none"> <li>- At the completion of data transferring from UARTi receive register to UARTi receive buffer register</li> </ul> </li> </ul>
Error detection	<ul style="list-style-type: none"> <li>• Overrun error (Note 3) This error occurs when the next data is ready before contents of UARTi receive buffer register are read out</li> <li>• Framing error This error occurs when the number set for stop bits is not detected</li> <li>• Parity error This error occurs in the case that parity is enabled and the number of "1" in parity bit and character bits does not match the number of "1" in parity odd/even setting.</li> <li>• Error sum flag This flag is set (= 1) when any of the overrun, framing, and parity errors is encountered</li> </ul>

Note 1: 'n' denotes the value 00<sub>16</sub> to FF<sub>16</sub> that is set to the UARTi bit rate register.

Note 2: f<sub>EXT</sub> is input from the CLKi pin.

Note 3: If an overrun error occurs, the UARTi receive buffer will have the next data written in. Also note that the UARTi receive interrupt request bit is not set to "1".

**Table.GA-6 Specifications of UART Mode (2)**

Item	Specification
Function selection	<ul style="list-style-type: none"> <li>• Separate <math>\overline{\text{CTS}}</math>/<math>\overline{\text{RTS}}</math> pins (UART0) Each of UART0 <math>\overline{\text{CTS}}</math> and <math>\overline{\text{RTS}}</math> pins can be assigned to separate pins</li> <li>• Sleep mode selection (UART0, UART1) This mode is used to transfer data to and from one of multiple slave micro-computers</li> <li>• Serial data logic switch (UART2) This function is reversing logic value of transferring data. Start bit, and stop bit are not reversed.</li> <li>• TxD, RxD I/O polarity switch (UART2) This function is reversing TxD port output and RxD port input. All I/O data level are reversed.</li> </ul>

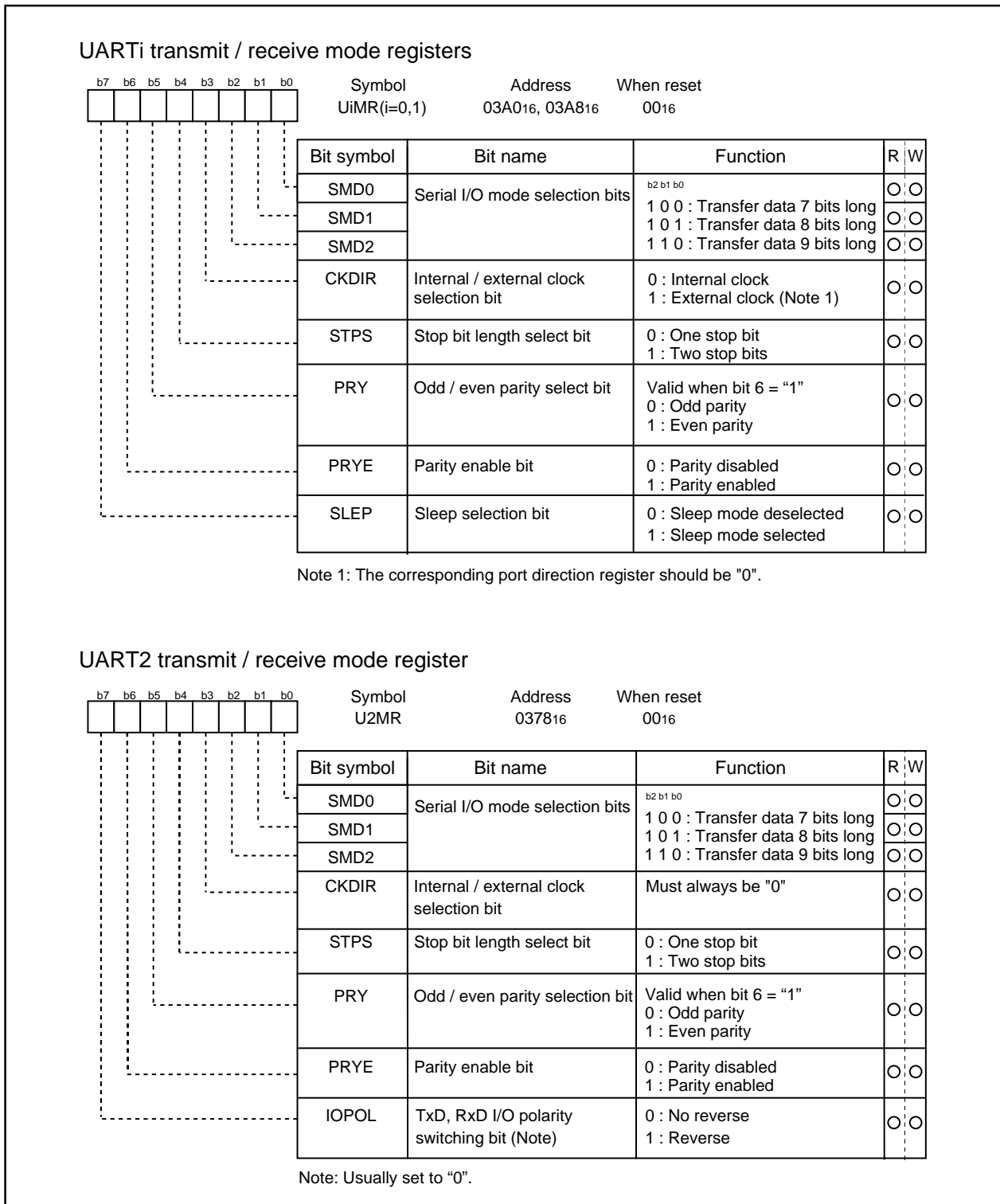

**Fig.GA-15 UARTi transmit/receive mode register in UART mode**

## Clock asynchronous serial I/O (UART) mode

Table.GA-7 lists the functions of the input/output pins during UART mode. This table shows the pin functions when the separate  $\overline{\text{CTS}}/\overline{\text{RTS}}$  pins function is not selected. Note that for a period from when the UARTi operation mode is selected to when transfer starts, the TxDi pin outputs a "H". (If the N-channel open-drain is selected, this pin is in floating state.)

**Table.GA-7 Input/output pin functions in UART mode (when  $\overline{\text{CTS}}/\overline{\text{RTS}}$  separate function is not selected)**

Pin name	Function	Method of selection
TxDi (P63,P67,P70)	Serial data output	
RxDi (P62,P66,P71)	Serial data input	Corresponding port direction register bit = "0".(Can be used as an input port when performing transmission only)
CLKi (P61,P65,P72)	Programmable I/O port	Internal/external clock selection bit (bit 3 at address 03A0 <sub>16</sub> , 03A8 <sub>16</sub> , 0378 <sub>16</sub> ) = "0"
	Transfer clock input	Internal/external clock selection bit (bit 3 at address 03A0 <sub>16</sub> , 03A8 <sub>16</sub> ) = "1" Corresponding port direction register bit = "0" (Don't select the external clock for UART2)
$\overline{\text{CTS}}/\overline{\text{RTS}}\text{i}$ (P60,P64,P73)	$\overline{\text{CTS}}$ input	$\overline{\text{CTS}}/\overline{\text{RTS}}$ disable bit (bit 4 at address 03A4 <sub>16</sub> , 03AC <sub>16</sub> , 037C <sub>16</sub> ) = "0" $\overline{\text{CTS}}/\overline{\text{RTS}}$ function selection bit (bit 2 at address 03A4 <sub>16</sub> , 03AC <sub>16</sub> , 037C <sub>16</sub> ) = "0" Corresponding port direction register bit = "0"
	$\overline{\text{RTS}}$ output	$\overline{\text{CTS}}/\overline{\text{RTS}}$ disable bit (bit 4 at address 03A4 <sub>16</sub> , 03AC <sub>16</sub> , 037C <sub>16</sub> ) = "0" $\overline{\text{CTS}}/\overline{\text{RTS}}$ function selection bit (bit 2 at address 03A4 <sub>16</sub> , 03AC <sub>16</sub> , 037C <sub>16</sub> ) = "1"
	Programmable I/O port	$\overline{\text{CTS}}/\overline{\text{RTS}}$ disable bit (bit 4 at address 03A4 <sub>16</sub> , 03AC <sub>16</sub> , 037C <sub>16</sub> ) = "1"



Clock asynchronous serial I/O (UART) mode

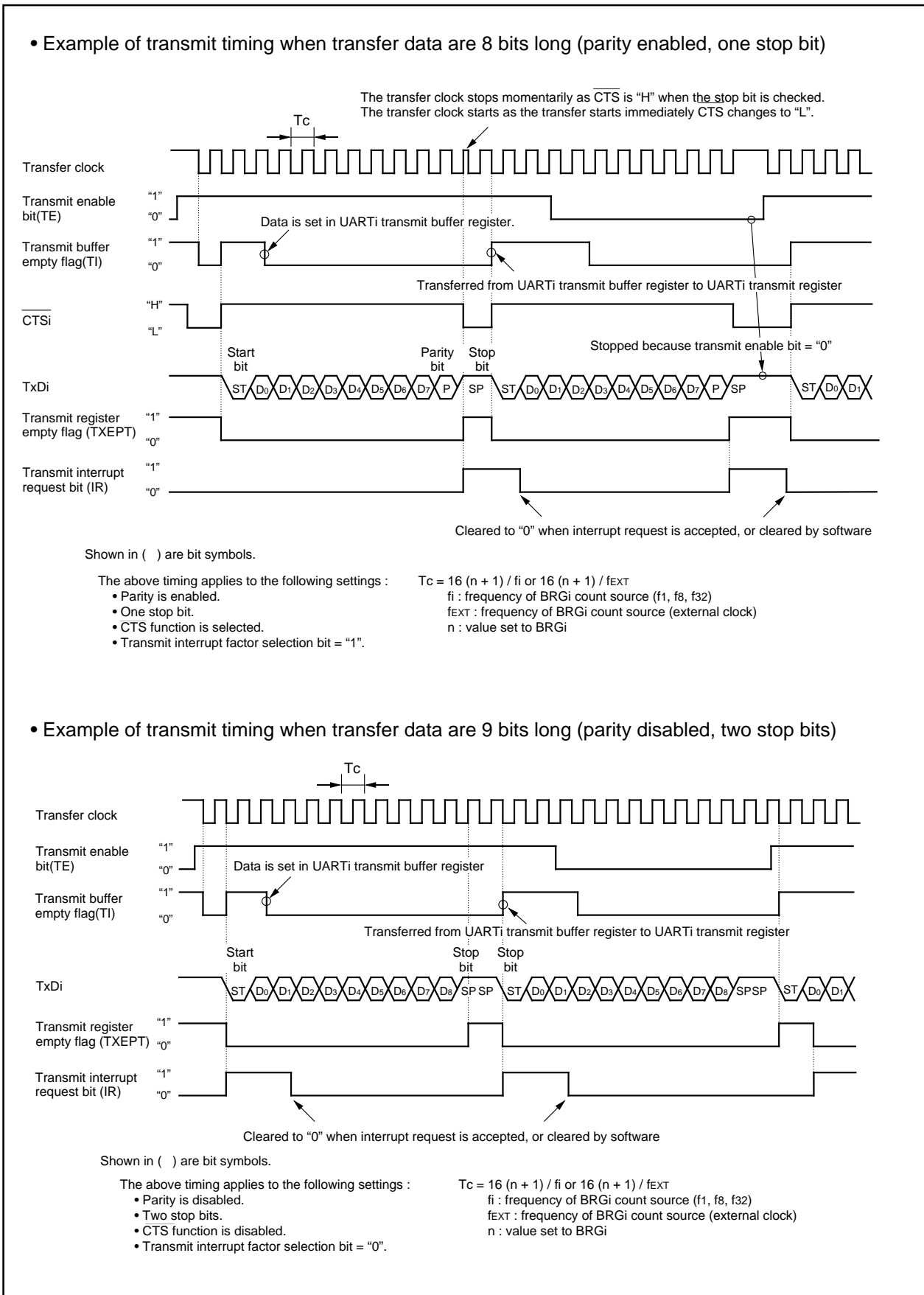

Fig.GA-16 Typical transmit timings in UART mode

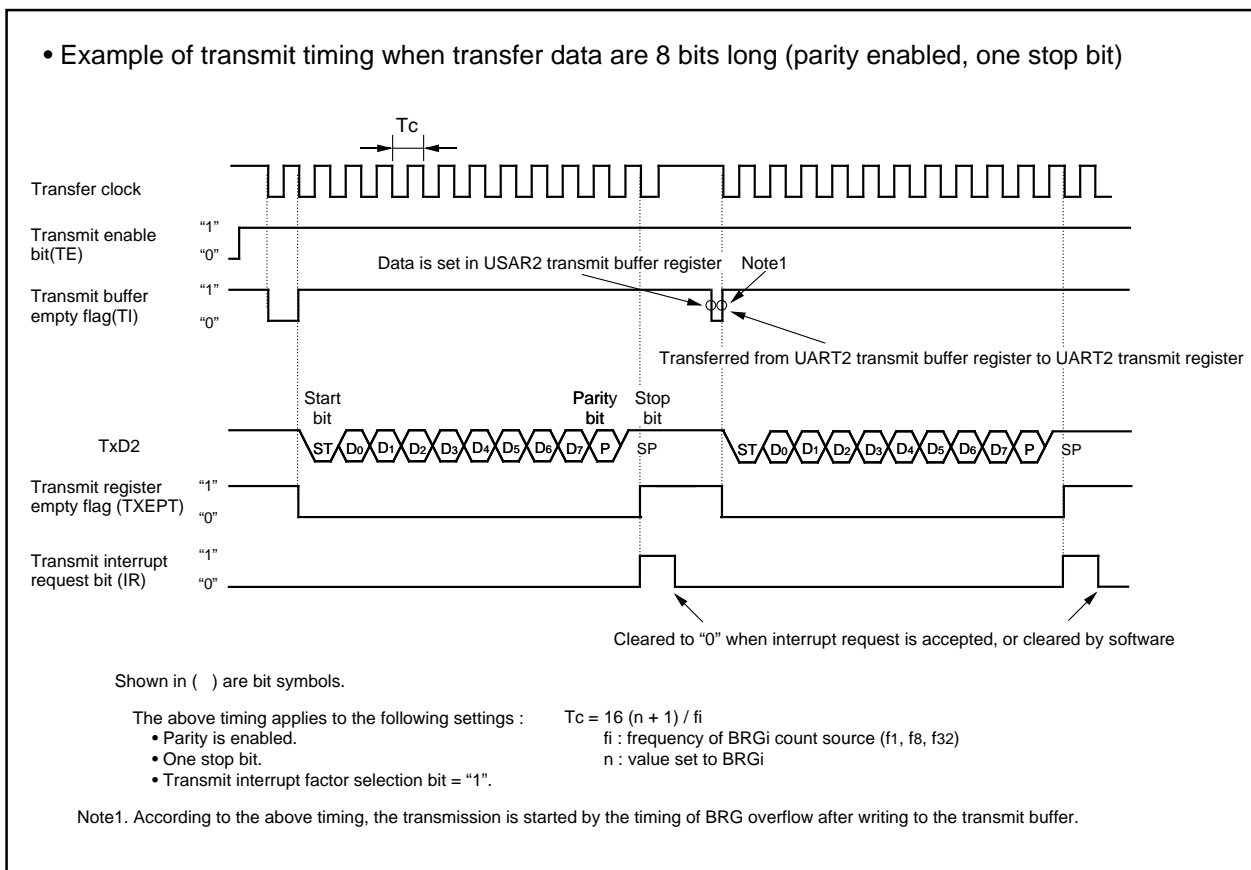

Fig.GA-17 Typical transmit timings in UART mode (UART2)

Clock asynchronous serial I/O (UART) mode

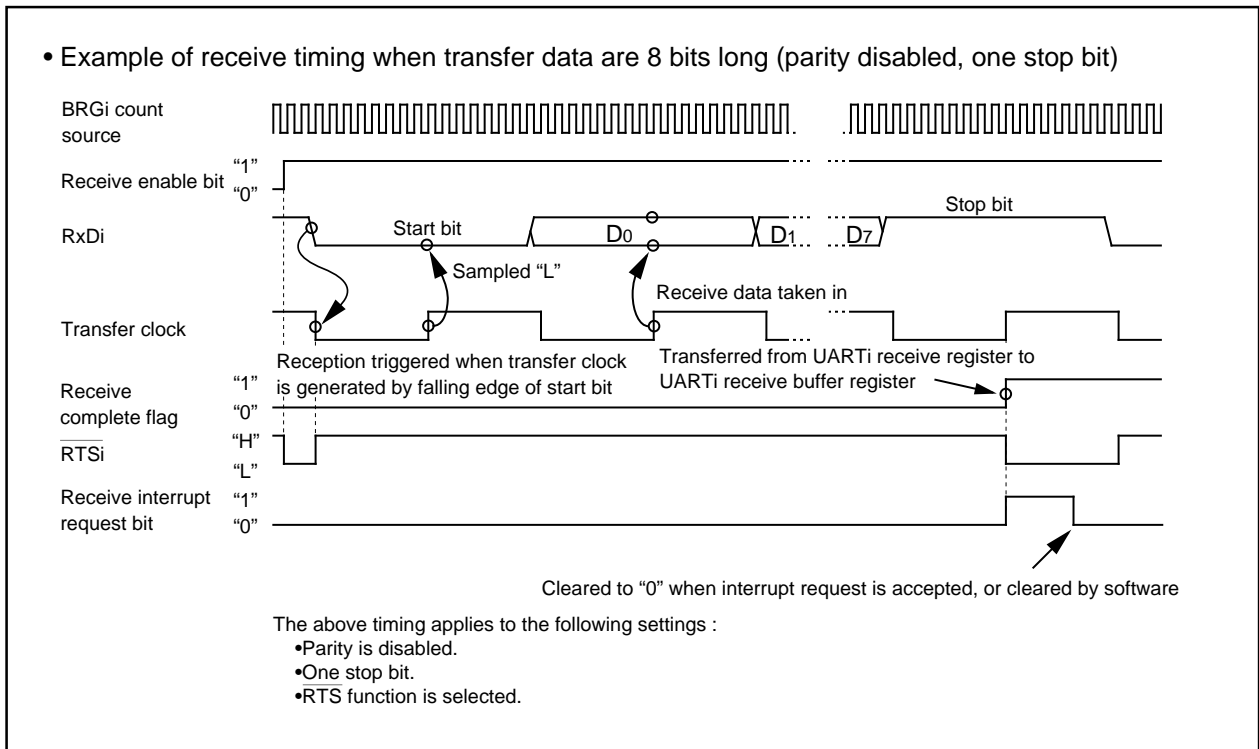

Fig.GA-18 Typical receive timing in UART mode

(a) Separate CTS/RTS pins function (UART0)

Setting the  $\overline{\text{CTS/RTS}}$  separate bit (bit 6 of address 03B016) to "1" separates the  $\overline{\text{RTS}}$  and  $\overline{\text{CTS}}$  signals to different input/out pins.(Fig GA-19). Choosing one from  $\overline{\text{CTS}}$  or  $\overline{\text{RTS}}$ , by using of the  $\overline{\text{CTS/RTS}}$  function selection bit (bit 2 of address 03A416). This function is effective in UART0 only. If the function is used, the user cannot use the  $\overline{\text{CTS/RTS}}$  function of UART1. Set "0" both to the  $\overline{\text{CTS/RTS}}$  function selection bit (bit 2 of address 03AC16) and to the  $\overline{\text{CTS/RTS}}$  disable bit (bit 4 of address 03AC16).

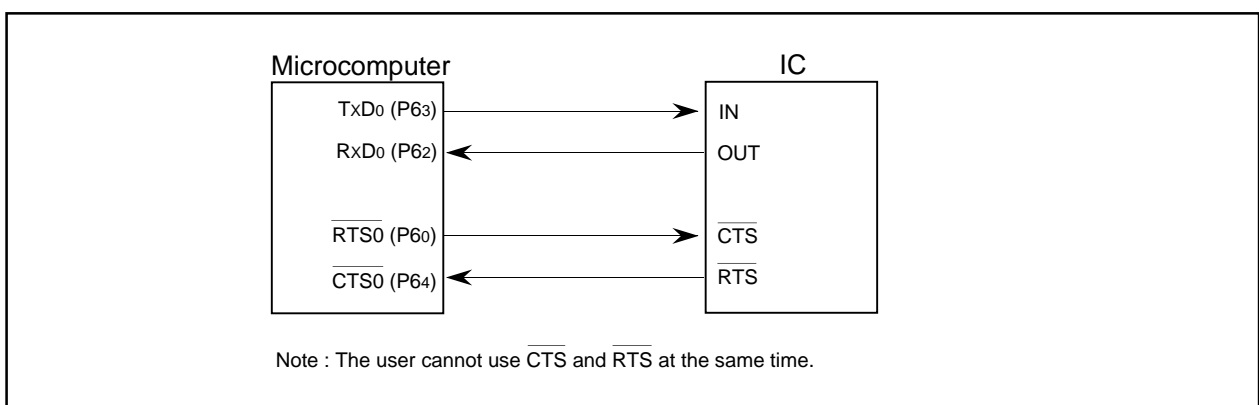

Fig.GA-19 The separate CTS/RTS pins function usage

(b) Sleep mode (UART0, UART1)

This mode is used to transfer data between specific microcomputers among multiple microcomputers connected with UARTi. The sleep mode is selected when the sleep selection bit (bit 7 at addresses 03A016, 03A816) is set to "1" during reception. In this mode, the unit performs receive operation when the MSB of the received data = "1" and does not perform receive operation when the MSB = "0".

**(c) Function for switching serial data logic (UART2)**

When the data logic selection bit (bit 6 of address 037D16) is assigned 1, data is inverted in writing to the transmission buffer register or reading the reception buffer register. Fig.GA-20 shows the example of timing for switching serial data logic.

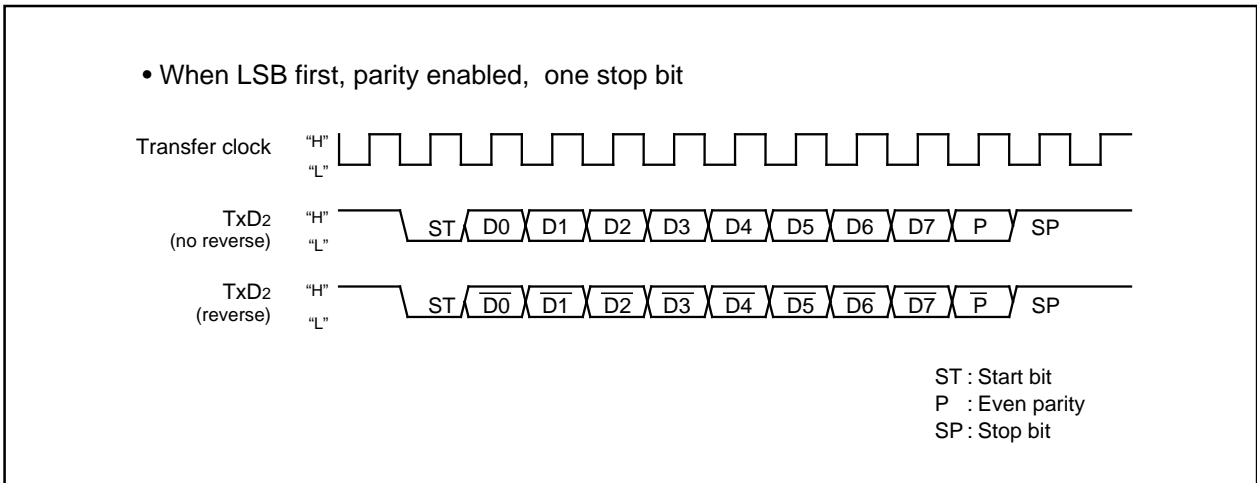

**Fig.GA-20 Timing for switching serial data logic**

**(d) TxD, RxD I/O polarity switching function (UART2)**

This function is to reverse TXD pin output and RXD pin input. The level of any data to be input or output (including the start bit, stop bit(s), and parity bit) is reversed. Set this function to "0" (not to reverse) for usual use.

**(e) Bus collision detection function (UART2)**

This function is to sample the output level of the TXD pin and the input level of the RXD pin at the rising edge of the transfer clock; if their values are different, then an interrupt request occurs. Fig.GA-21 shows the example of detection timing of a bus collision (in UART mode).

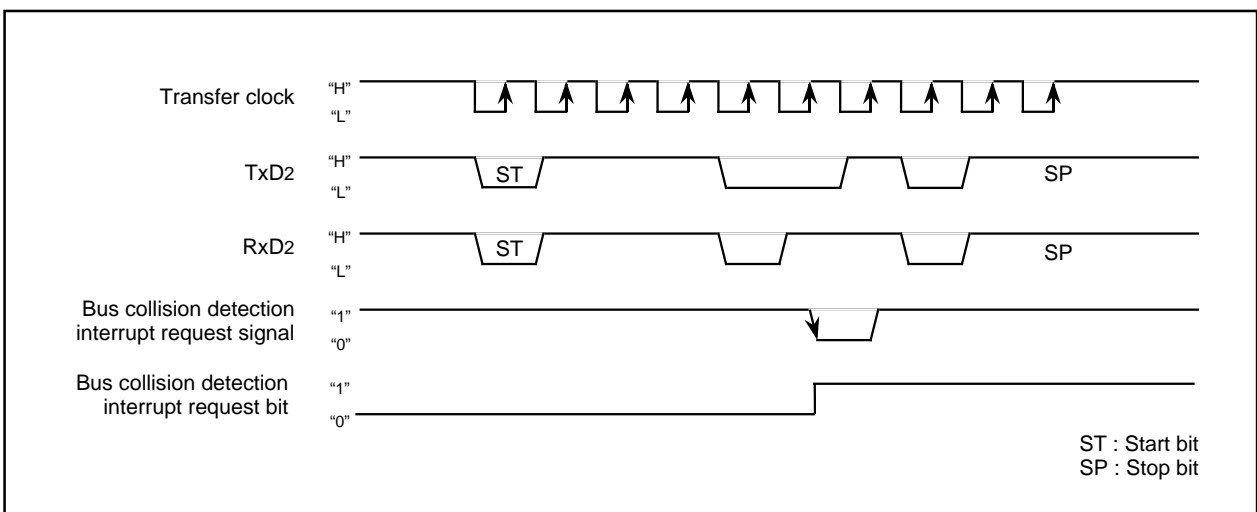

**Fig.GA-21 Detection timing of a bus collision (in UART mode)**

## Clock asynchronous serial I/O (UART) mode

**(3) Clock-asynchronous serial I/O mode (compliant with the SIM interface)**

The SIM interface is used for connecting the microcomputer with a memory card IC or the like; adding some extra settings in UART2 clock-asynchronous serial I/O mode allows the user to effect this function. Table.GA-8 shows the specifications of clock-asynchronous serial I/O mode (compliant with the SIM interface).

**Table.GA-8 Specifications of clock-asynchronous serial I/O mode (compliant with SIM I/F)**

Item	Specification
Transfer data format	<ul style="list-style-type: none"> <li>• Transfer data 8-bit UART mode (bit 2 through bit 0 of address 0378<sub>16</sub> = "1012")</li> <li>• One stop bit (bit 4 of address 0378<sub>16</sub> = "0")</li> <li>• With the direct format chosen           <ul style="list-style-type: none"> <li>Set parity to "even" (bit 5 and bit 6 of address 0378<sub>16</sub> = "1" and "1" respectively)</li> <li>Set data logic to "direct" (bit 6 of address 037D<sub>16</sub> = "0").</li> <li>Set transfer format to LSB (bit 7 of address 037C<sub>16</sub> = "0").</li> </ul> </li> <li>• With the inverse format chosen           <ul style="list-style-type: none"> <li>Set parity to "odd" (bit 5 and bit 6 of address 0378<sub>16</sub> = "0" and "1" respectively)</li> <li>Set data logic to "inverse" (bit 6 of address 037D<sub>16</sub> = "1")</li> <li>Set transfer format to MSB (bit 7 of address 037C<sub>16</sub> = "1")</li> </ul> </li> </ul>
Transfer clock	<ul style="list-style-type: none"> <li>• With the internal clock chosen (bit 3 of address 0378<sub>16</sub> = "0") : <math>f_i / 16 (n + 1)</math> (Note 1) : <math>f_i = f_1, f_8, f_{32}</math></li> <li>• Don't chose external clock.</li> </ul>
Transmission / reception control	<ul style="list-style-type: none"> <li>• Disable the <math>\overline{CTS}</math> and <math>\overline{RTS}</math> function (bit 4 of address 037C<sub>16</sub> = "1")</li> </ul>
Other settings	<ul style="list-style-type: none"> <li>• The sleep mode selection function is not available for UART2</li> <li>• Set transmission interrupt factor to "transmission completed" (bit 4 of address 037D<sub>16</sub> = "1")</li> </ul>
Transmission start condition	<ul style="list-style-type: none"> <li>• To start transmission, the following requirements must be met:           <ul style="list-style-type: none"> <li>- Transmit enable bit (bit 0 of address 037D<sub>16</sub>) = "1"</li> <li>- Transmit buffer empty flag (bit 1 of address 037D<sub>16</sub>) = "0"</li> </ul> </li> </ul>
Reception start condition	<ul style="list-style-type: none"> <li>• To start reception, the following requirements must be met:           <ul style="list-style-type: none"> <li>- Reception enable bit (bit 2 of address 037D<sub>16</sub>) = "1"</li> <li>- Detection of a start bit</li> </ul> </li> </ul>
Interrupt request generation timing	<ul style="list-style-type: none"> <li>• When transmitting           <ul style="list-style-type: none"> <li>When data transmission from the UART2 transfer register is completed (bit 4 of address 037D<sub>16</sub> = "1")</li> </ul> </li> <li>• When receiving           <ul style="list-style-type: none"> <li>When data transfer from the UART2 receive register to the UART2 receive buffer register is completed</li> </ul> </li> </ul>
Error detection	<ul style="list-style-type: none"> <li>• Overrun error (see the specifications of clock-asynchronous serial I/O) (Note 2)</li> <li>• Framing error (see the specifications of clock-asynchronous serial I/O)</li> <li>• Parity error (see the specifications of clock-asynchronous serial I/O)           <ul style="list-style-type: none"> <li>- On the reception side, an "L" level is output from the TxD<sub>2</sub> pin by use of the parity error signal output function (bit 7 of address 037D<sub>16</sub> = "1") when a parity error is detected</li> <li>- On the transmission side, a parity error is detected by the level of input to the RxD<sub>2</sub> pin when a transmission interrupt occurs</li> </ul> </li> <li>• The error sum flag (see the specifications of clock-asynchronous serial I/O)</li> </ul>

Note 1: 'n' denotes the value 00<sub>16</sub> to FF<sub>16</sub> that is set to the UART<sub>i</sub> bit rate generator.

Note 2: If an overrun error occurs, the UART2 receive buffer will have the next data written in. Also Note that the UART<sub>i</sub> receive interrupt request bit is not set to "1".

Clock asynchronous serial I/O (UART) mode

SINGLE-CHIP 16-BIT CMOS MICROCOMPUTER

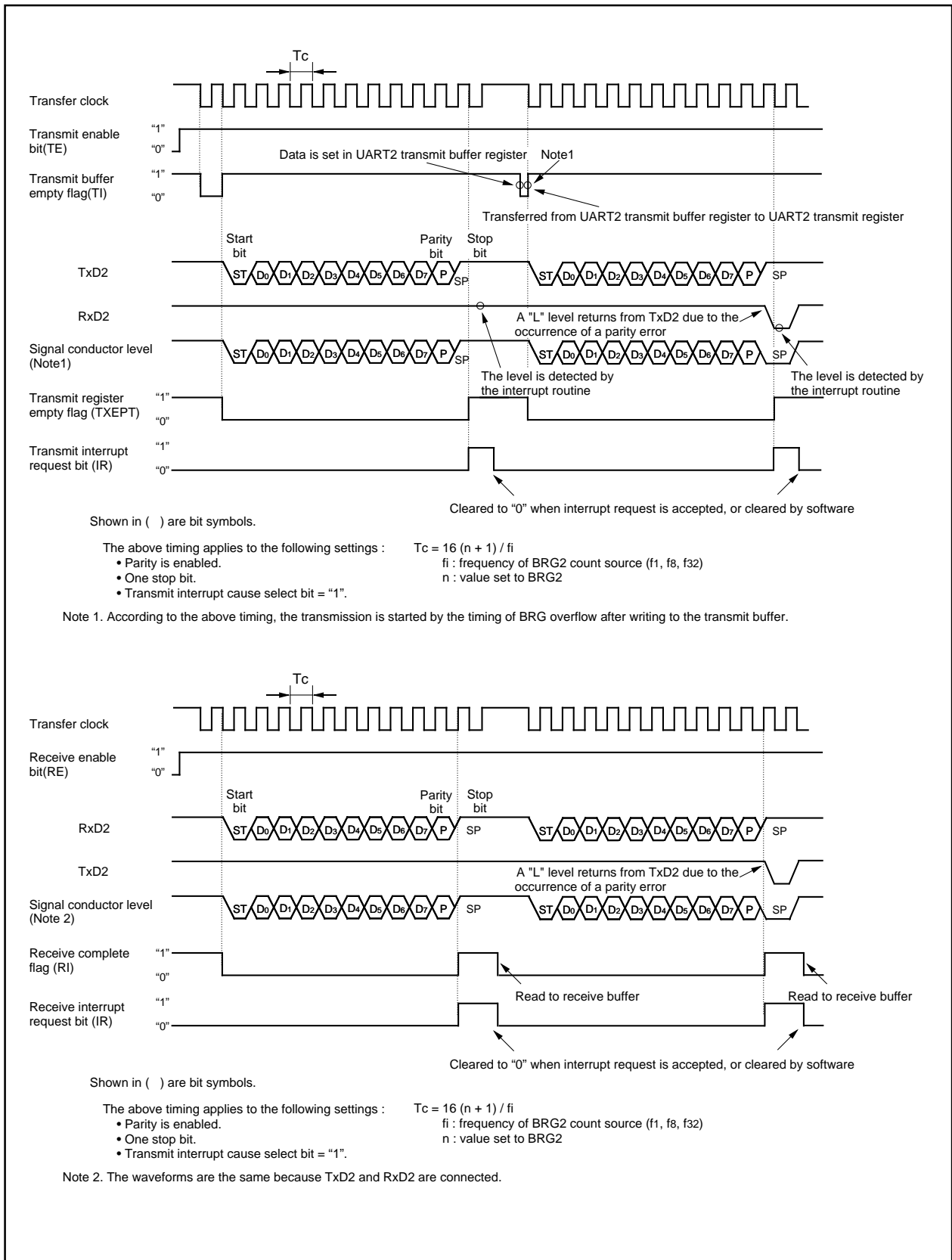
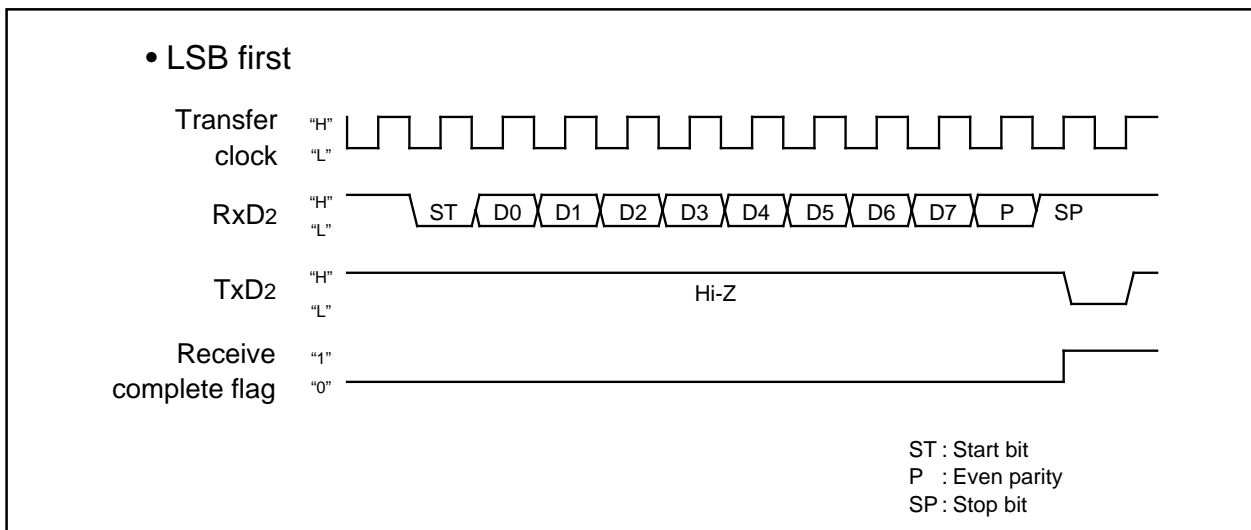

Fig.GA-22 Typical transmit/receive timing in UART mode (compliant with the SIM interface)

Clock asynchronous serial I/O (UART) mode

**(a) Function for outputting a parity error signal**

With the error signal output enable bit (bit 7 of address 037D16) assigned "1", an "L" level from the TxD2 pin will be output when a parity error is detected. Link with this function, the timing to generate a transmission completion interrupt varies according to the timing of a parity error signal detection. Fig.GA-23 shows the timing of the parity error signal output.

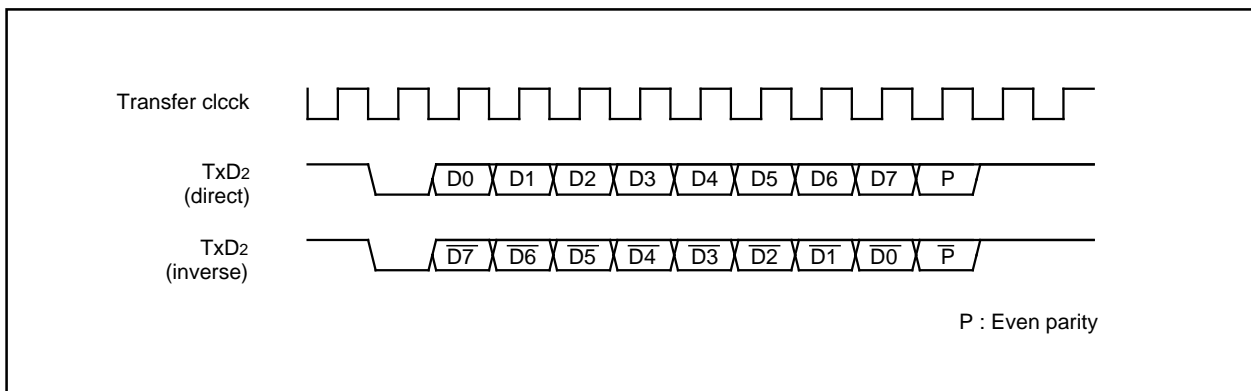

**Fig.GA-23 Timing of the parity error signal output**

**(b) Direct format/inverse format**

Connecting the SIM card allows you to switch between direct format and inverse format. If you choose the direct format, data are output from TxD2 beginning with D0. If you choose the inverse format, data are inverted and output from TxD2 beginning with D7.

Fig.GA-24 shows the SIM interface format.



**Fig.GA-24 SIM interface format**

## Clock asynchronous serial I/O (UART) mode

Fig.GA-25 shows the example of connecting the SIM interface. Connect TxD2 and RxD2 and apply pull-up.

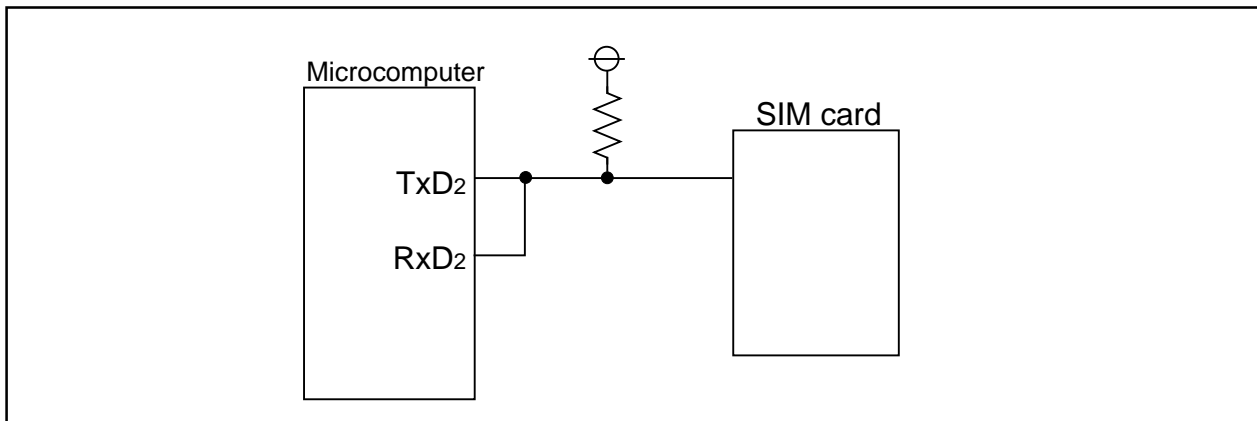

Fig.GA-25 Connecting the SIM interface



## UART2 Special Mode Register

The UART2 special mode register (address 037716) is used to control UART2 in various ways.

Fig.GA-26 shows the UART2 special mode register.

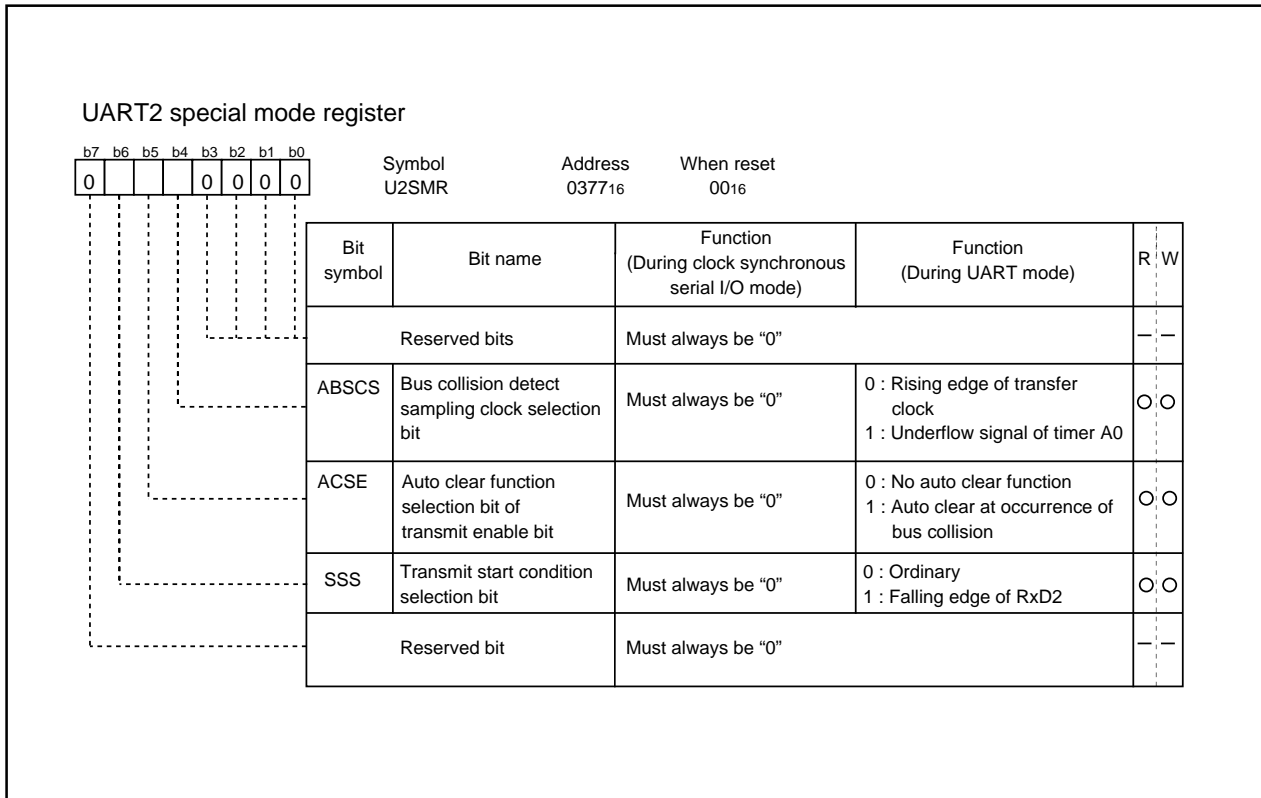

Fig.GA-26 UART2 special mode register

Some other functions added are explained here. Fig.GA-27 shows their workings.

Bit 4 of the UART2 special mode register is used as the bus collision detect sampling clock selection bit. The bus collision detect interrupt occurs when the RxD2 level and TxD2 level do not match, but the nonconformity is detected in synchronization with the rising edge of the transfer clock signal if the bit is set to "0". If this bit is set to "1", the nonconformity is detected at the timing of the overflow of timer A0 rather than at the rising edge of the transfer clock.

Bit 5 of the UART2 special mode register is used as the auto clear function selection bit of transmit enable bit. Setting this bit to "1" automatically resets the transmit enable bit to "0" when "1" is set in the bus collision detect interrupt request bit (nonconformity).

Bit 6 of the UART2 special mode register is used as the transmit start condition selection bit. Setting this bit to "1" starts the TxD transmission in synchronization with the falling edge of the RxD pin.

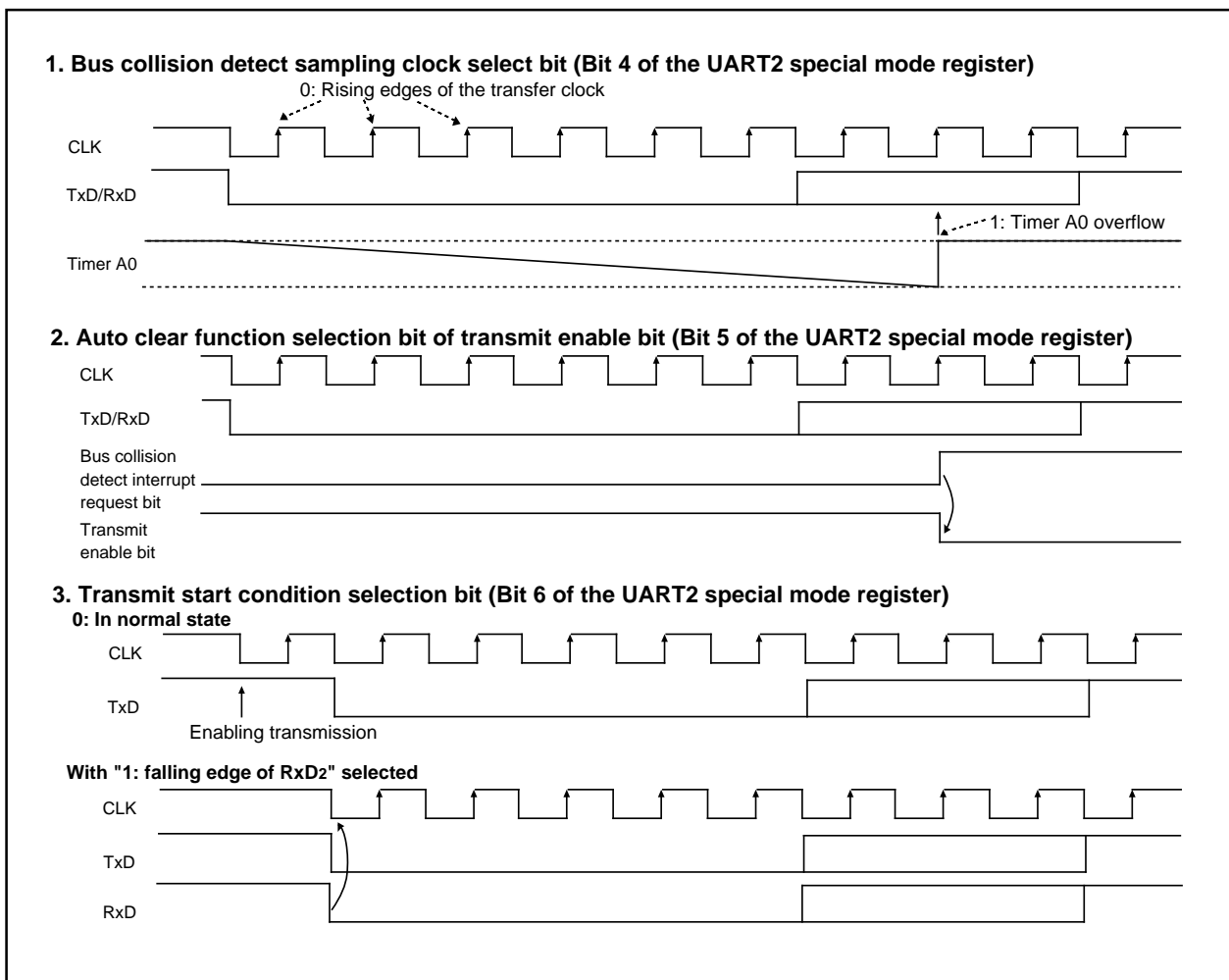

Fig.GA-27 Some other functions added

**S I/O3, 4**

S I/O 3 and S I/O 4 are exclusive clock-synchronous serial I/Os.

Fig.GA-28 shows the S I/O 3, 4 block diagram, and Fig.GA-29 shows the S I/O 3, 4 control register.

Table.GA-9 shows the specifications of S I/O 3, 4.

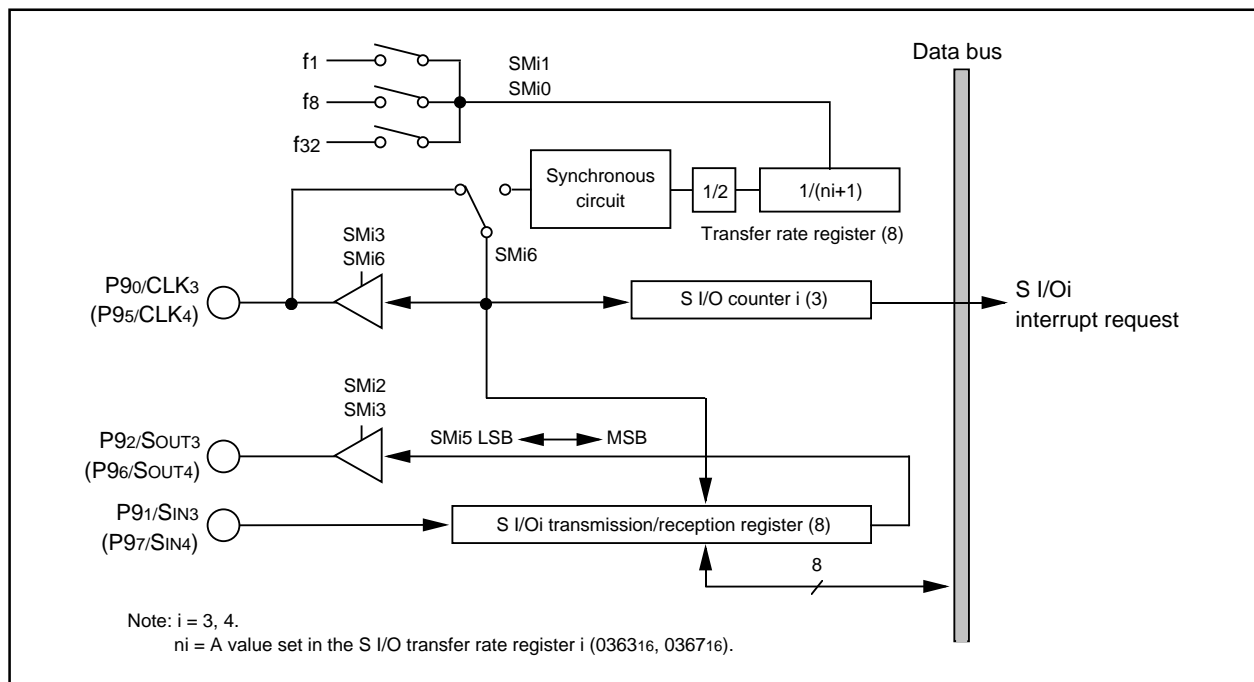

**Fig.GA-28 S I/O3, 4 block diagram**

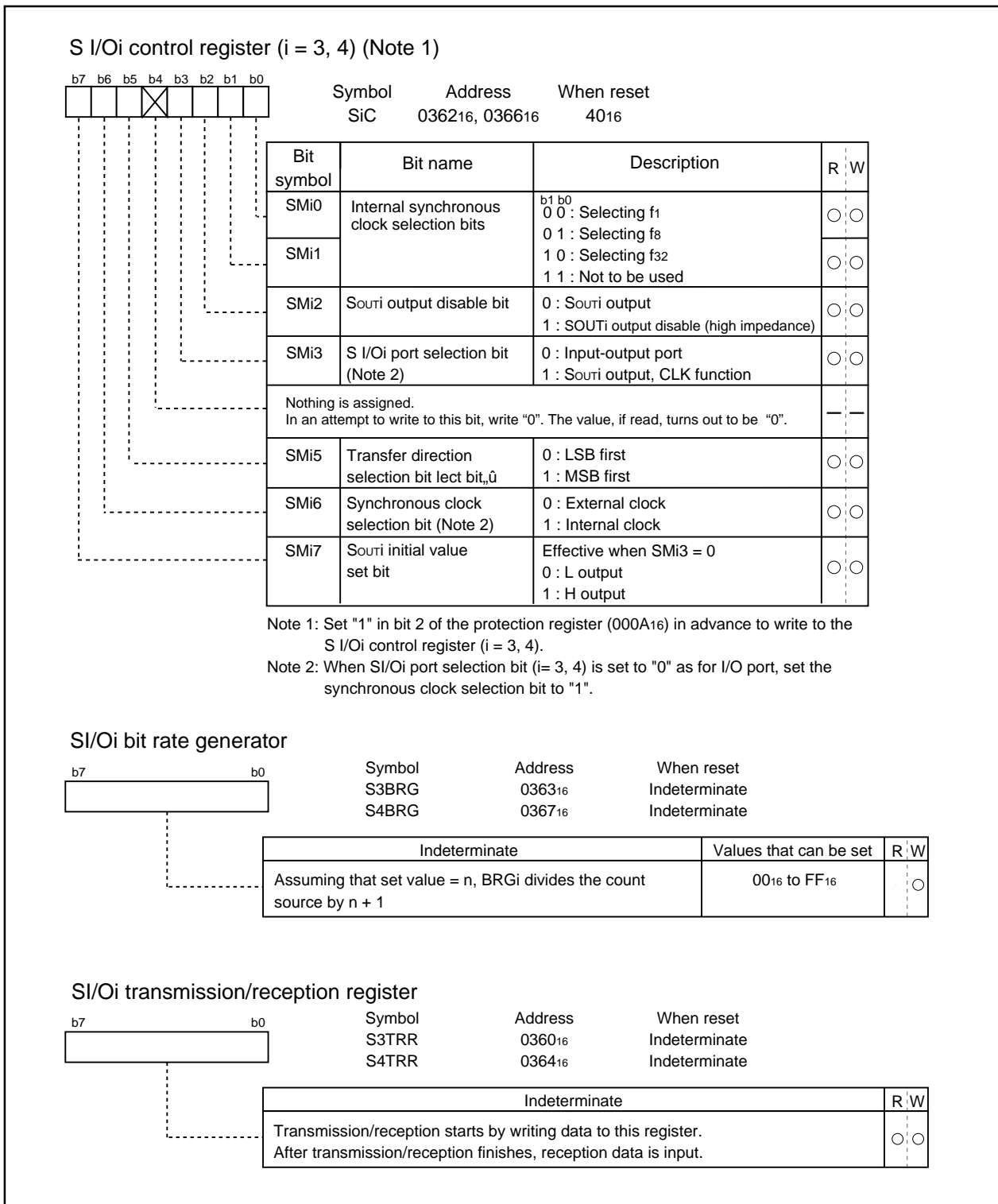

Fig.GA-29 S I/O3, 4 control registers

Table.GA-9 Specifications of S I/O3, 4

Item	Specifications
Transfer data format	<ul style="list-style-type: none"> <li>• Transfer data length: 8 bits</li> </ul>
Transfer clock	<ul style="list-style-type: none"> <li>• With the internal clock selected (bit 6 of 0362<sub>16</sub>, 0366<sub>16</sub> = "1"): <math>f_1/2(ni+1)</math>, <math>f_8/2(ni+1)</math>, <math>f_{32}/2(ni+1)</math> (Note 1)</li> <li>• With the external clock selected (bit 6 of 0362<sub>16</sub>, 0366<sub>16</sub> = 0): Input from the CLK<sub>i</sub> terminal (Note 2)</li> </ul>
Conditions for transmission/reception start	<ul style="list-style-type: none"> <li>• To start transmit/reception, the following requirements must be met: <ul style="list-style-type: none"> <li>- Select the synchronous clock (use bit 6 of 0362<sub>16</sub>, 0366<sub>16</sub>).</li> <li>Select a frequency dividing ratio if the internal clock has been selected (use bits 0 and 1 of 0362<sub>16</sub>, 0366<sub>16</sub>).</li> <li>- SOUT<sub>i</sub> initial value set bit (use bit 7 of 0362<sub>16</sub>, 0366<sub>16</sub>) = 1.</li> <li>- S I/O<sub>i</sub> port select bit (bit 3 of 0362<sub>16</sub>, 0366<sub>16</sub>) = 1.</li> <li>- Select the transfer direction (use bit 5 of 0362<sub>16</sub>, 0366<sub>16</sub>)</li> <li>- Write transfer data to SI/O<sub>i</sub> transmission/reception register(0360<sub>16</sub>, 0364<sub>16</sub>)</li> </ul> </li> <li>• To use S I/O<sub>i</sub> interrupts, the following requirements must be met: <ul style="list-style-type: none"> <li>- S I/O<sub>i</sub> interrupt request bit (bit 3 of 0049<sub>16</sub>, 0048<sub>16</sub>) = 0.</li> </ul> </li> </ul>
Interrupt request generation timing	<ul style="list-style-type: none"> <li>• At the rising edge of the last transfer clock (Note3)</li> </ul>
Select function	<ul style="list-style-type: none"> <li>• LSB first or MSB first selection Whether transmission/reception begins with bit 0 (LSB) or bit 7 (MSB) can be selected.</li> <li>• The SOUT<sub>i</sub> default value setting function If the transfer clock is selected to external clock, the output level of SOUT<sub>i</sub> pin can be selected when it is not in transferring please refer to Fig.GA-30.</li> </ul>
Precaution	<ul style="list-style-type: none"> <li>• The SI/O<sub>i</sub> (i=3,4) is different from UART0 to 2 that the register and buffer can not be separated, so don't write the next transfer data to the transmission/reception register(0360<sub>16</sub>, 0364<sub>16</sub>) during transferring.</li> <li>• If the transfer clock is selected to internal clock, at the end of transferring, the SOUT<sub>i</sub> holds the last data during the last 1/2 transfer clock, and then to high impedance. If the transmission/reception register(0360<sub>16</sub>, 0364<sub>16</sub>) is written during the period, the SOUT<sub>i</sub> becomes the high impedance right the writing, the data hold time will be shortened.</li> </ul>

Note 1: n is a value from 00<sub>16</sub> through FF<sub>16</sub> set in the S I/O<sub>i</sub> transfer rate register (i = 3, 4).

Note 2: With the external clock selected:

- Please write to the SI/O<sub>i</sub> transmission/reception register(0360<sub>16</sub>, 0364<sub>16</sub>) under the status that the CLK<sub>i</sub> pin is input to "H" level. Also please write to the bit 7(SOUT<sub>i</sub> default value setting bit) under the status that the CLK<sub>i</sub> pin is input to "H" level.
- The S I/O<sub>i</sub> circuit keeps on with the shift operation as long as the synchronous clock is entered in it, so stop the synchronous clock at the instant when it counts to eight. The internal clock, if selected, automatically stops.

Note 3: If the internal clock is used for the synchronous clock, the transfer clock signal stops at the "H" state.

**■ Functions for setting an SOUTi initial value**

In carrying out transmission, the output level of the SOUTi pin as it is before transmitting 1-bit data can be set either to "H" or to "L". Fig.GA-30 shows the timing chart for setting an SOUTi initial value and how to set it.

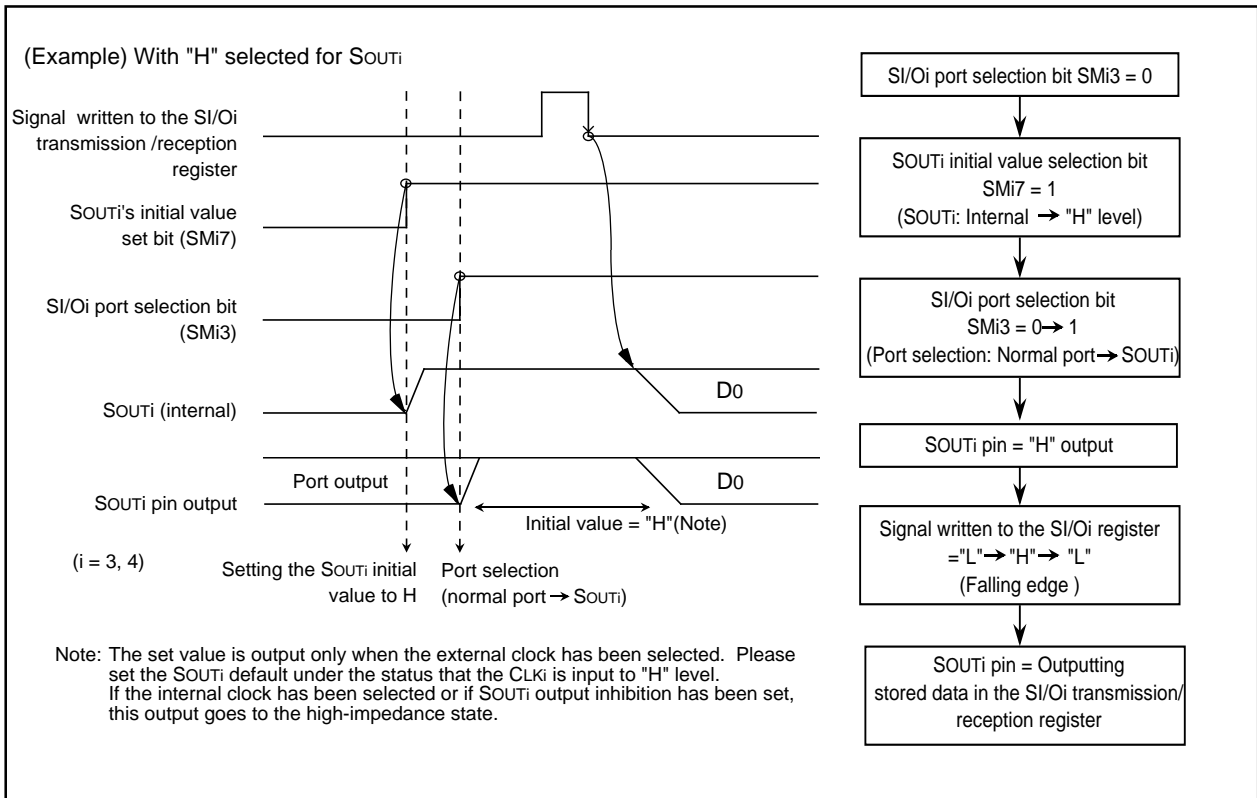

**Fig.GA-30** Timing chart for setting SOUTi's initial value and how to set it

**■ S I/Oi operation timing**

Fig.GA-31 shows the S I/Oi operation timing

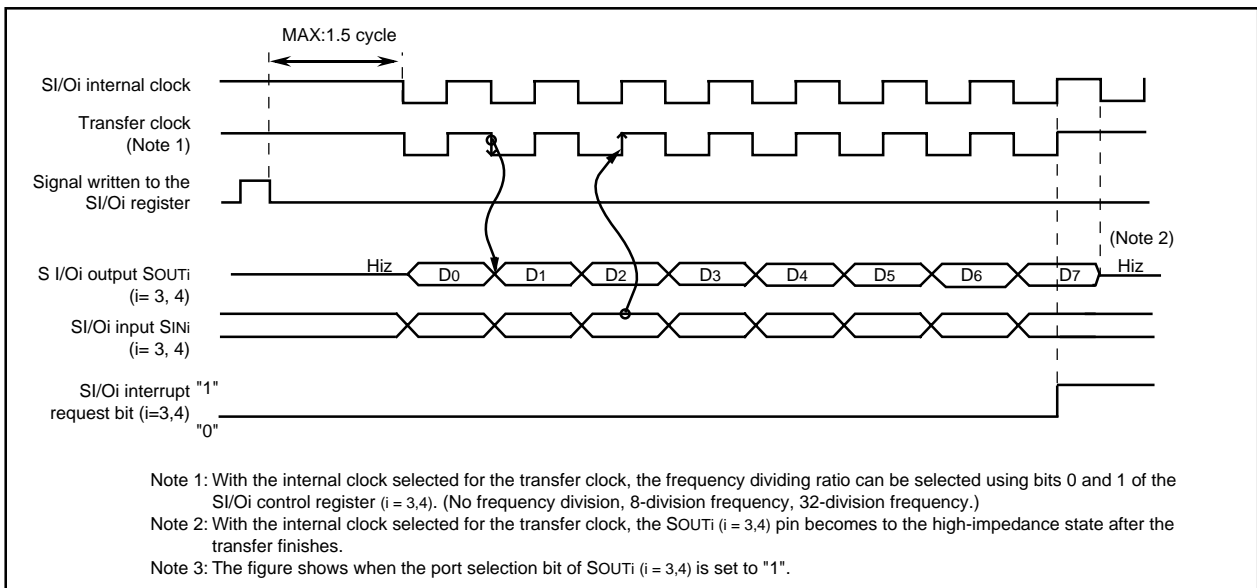

**Fig.GA-31** S I/Oi operation timing chart

## A-D Converter

The A-D converter consists of one 10-bit successive approximation A-D converter circuit with a capacitive coupling amplifier. Pins P10<sub>0</sub> to P10<sub>7</sub>, P9<sub>5</sub>, and P9<sub>6</sub> also function as the analog signal input pins. The direction registers of these pins for A-D conversion must therefore be set to input. The Vref connect bit (bit 5 at address 03D7<sub>16</sub>) can be used to isolate the resistance ladder of the A-D converter from the reference voltage input pin (VREF) when the A-D converter is not used. Doing so stops any current flowing into the resistance ladder from VREF, reducing the power dissipation. When using the A-D converter, start A-D conversion only after setting bit 5 of 03D7<sub>16</sub> to connect VREF.

The result of A-D conversion is stored in the A-D registers of the selected pins. When set to 10-bit precision, the low 8 bits are stored in the even addresses and the high 2 bits in the odd addresses. When set to 8-bit precision, the low 8 bits are stored in the even addresses.

Table.JA-1 shows the performance of the A-D converter. Fig.JA-1 shows the block diagram of the A-D converter, and Fig.JA-2 and JA-3 show the A-D converter-related registers.

**Table.JA-1 Performance of A-D converter**

Item	Performance
Method of A-D conversion	Successive approximation (capacitive coupling amplifier)
Analog input voltage	0V to AVCC (VCC)
Operating clock $\phi_{AD}$ (Note1)	fAD/divide-by-2 of fAD/divide-by-4 of fAD, fAD=f(XIN)
Resolution	8-bit or 10-bit (selectable)
Absolute precision	<ul style="list-style-type: none"> <li>• 8-bit resolution ±2LSB</li> <li>• 10-bit resolution ±6LSB</li> </ul>
Operating modes	One-shot mode, repeat mode, single sweep mode, repeat sweep mode 0, and repeat sweep mode 1
Analog input pins	8pins (AN <sub>0</sub> to AN <sub>7</sub> ) + 2pins (ANEX <sub>0</sub> and ANEX <sub>1</sub> )
A-D conversion start condition	<ul style="list-style-type: none"> <li>• Software trigger A-D conversion starts when the A-D conversion start flag changes to "1"</li> <li>• External trigger (can be retriggered) A-D conversion starts when the A-D conversion start flag is "1" and the <math>\overline{ADTRG}/P97</math> input changes from "H" to "L"</li> </ul>
Conversion speed per pin	<ul style="list-style-type: none"> <li>• Without sample and hold function 8-bit resolution : 49 <math>\phi_{AD}</math> cycles 10-bit resolution : 59 <math>\phi_{AD}</math> cycles</li> <li>• With sample and hold function 8-bit resolution : 28 <math>\phi_{AD}</math> cycles 10-bit resolution : 33 <math>\phi_{AD}</math> cycles</li> </ul>

Note 1: Without sample and hold function, set the  $\phi_{AD}$  frequency to 250kHz min.

With the sample and hold function, set the  $\phi_{AD}$  frequency to 1MHz min.

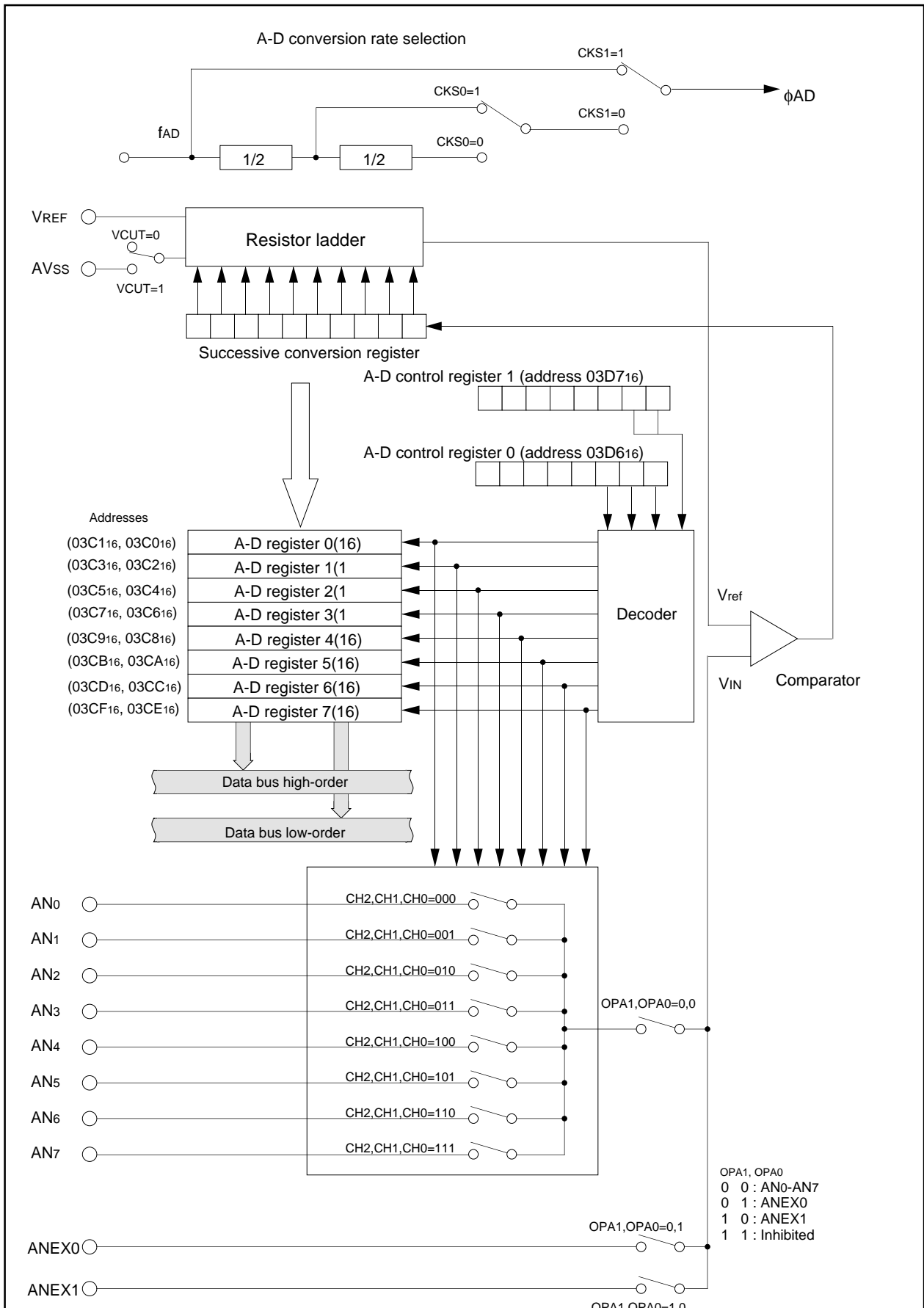

**Fig.JA-1** Block diagram of A-D converter



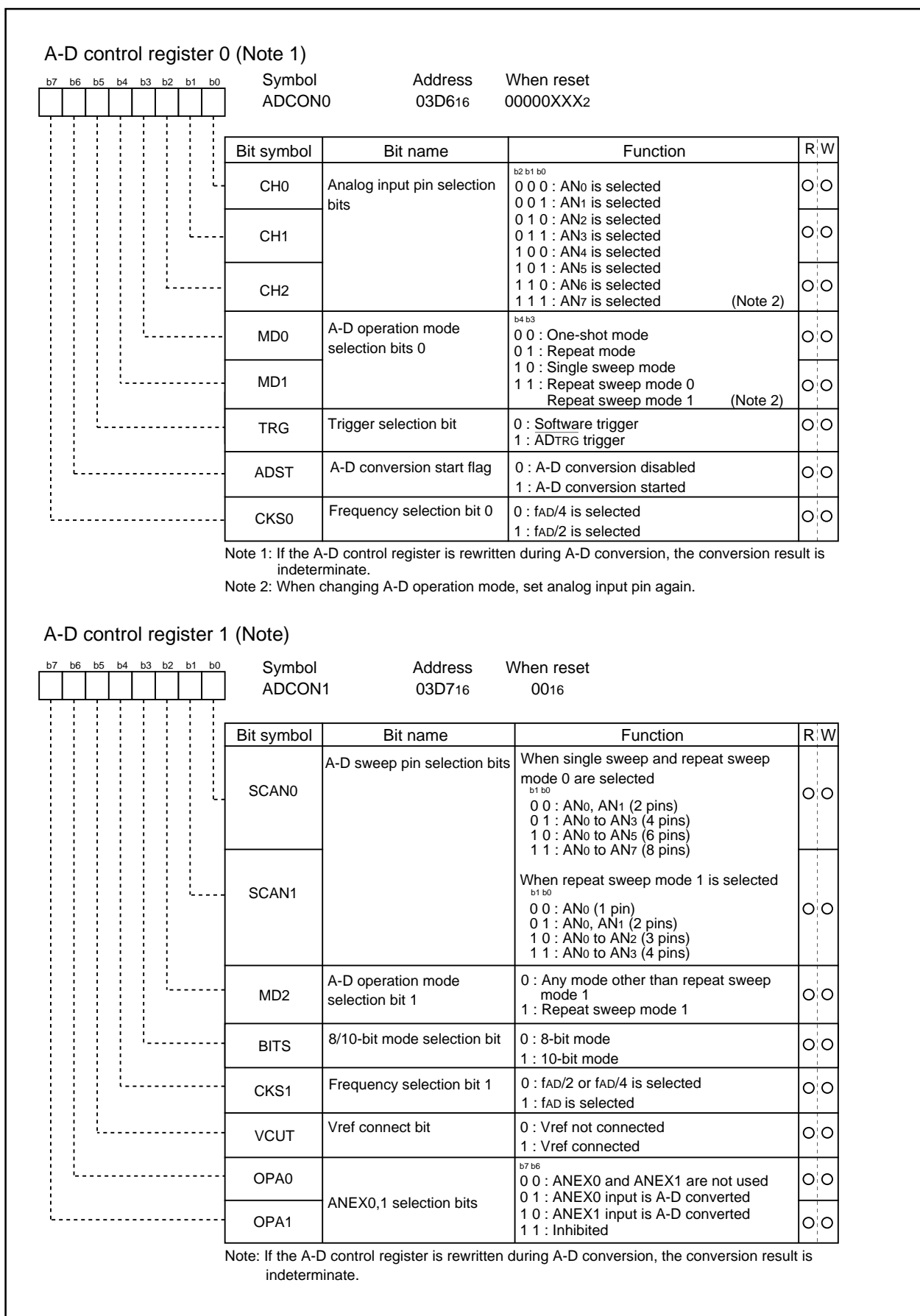

Fig.JA-2 A-D converter-related registers (1)

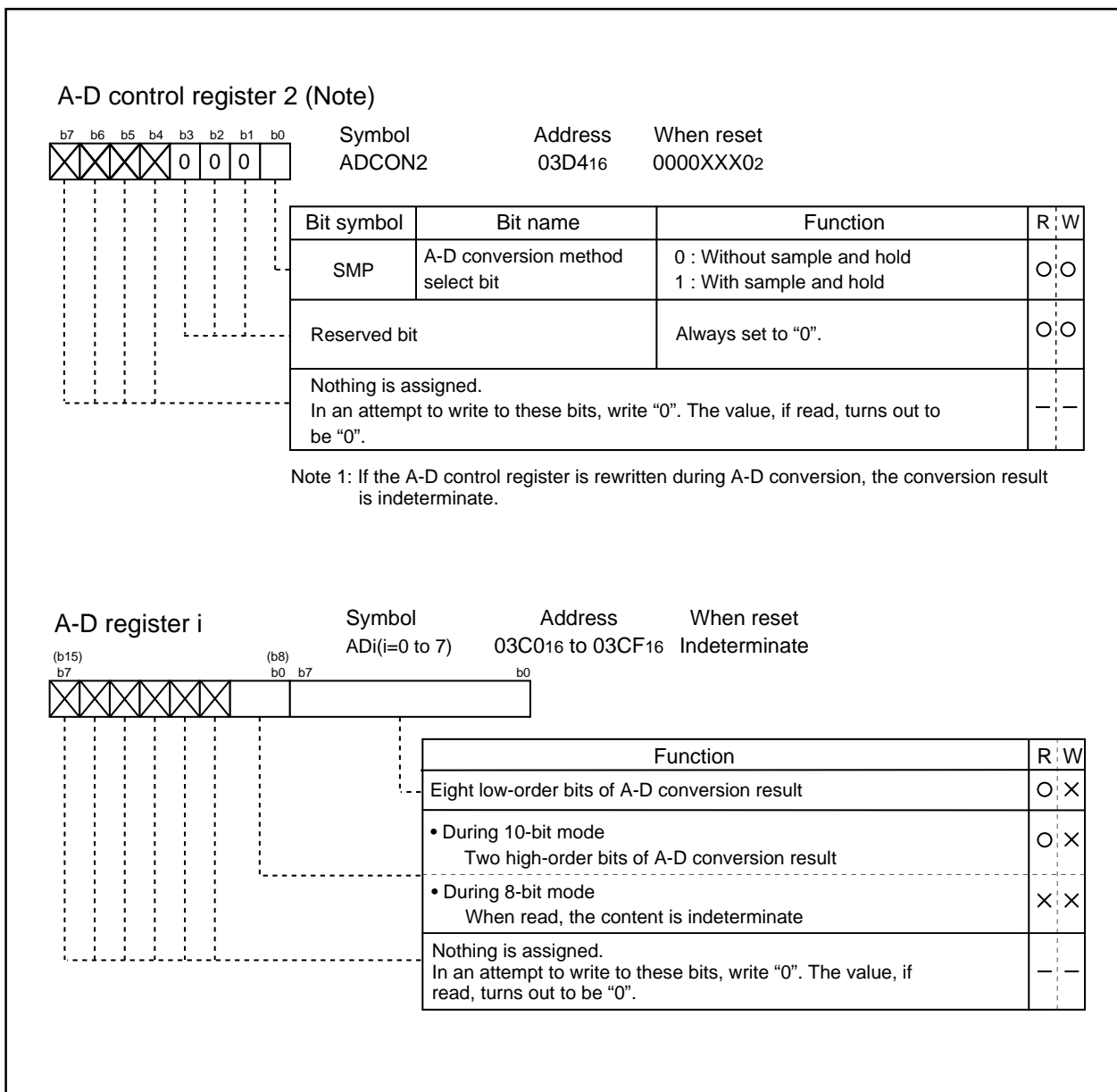

Fig.JA-3 A-D converter-related registers (2)

**(1) One-shot mode**

In one-shot mode, the pin selected using the analog input pin selection bits is used for one-shot A-D conversion. Table.JA-2 shows the specifications of one-shot mode. Fig.JA-4 shows the A-D control register in one-shot mode.

**Table.JA-2 One-shot mode specifications**

Item	Specification
Function	The pin selected by the analog input pin selection bits is used for one A-D conversion
Start condition	Writing "1" to A-D conversion start flag
Stop condition	<ul style="list-style-type: none"> <li>End of A-D conversion (A-D conversion start flag changes to "0", except when external trigger is selected)</li> <li>Writing "0" to A-D conversion start flag</li> </ul>
Interrupt request generation timing	End of A-D conversion
Input pin	One of AN <sub>0</sub> to AN <sub>7</sub> , as selected
Reading of result of A-D converter	Read A-D register corresponding to selected pin

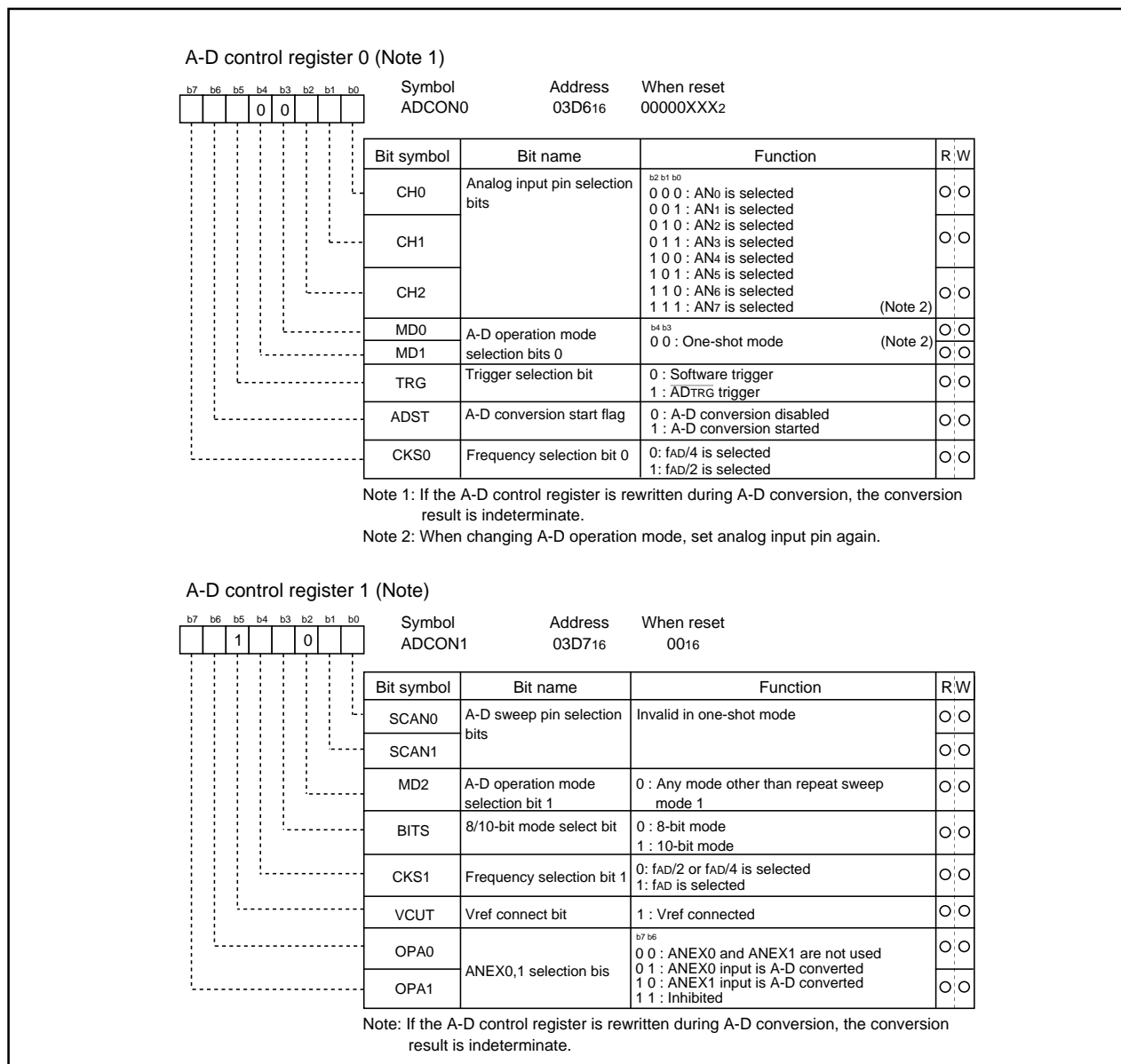
**Fig.JA-4 A-D conversion register in one-shot mode**

**(2) Repeat mode**

In repeat mode, the pin selected using the analog input pin selection bits is used for repeated A-D conversion. Table.JA-3 shows the specifications of repeat mode. Fig.JA-5 shows the A-D control register in repeat mode.

**Table.JA-3 Repeat mode specifications**

Item	Specification
Function	The pin selected by the analog input pin selection bits is used for repeated A-D conversion
Star condition	Writing "1" to A-D conversion start flag
Stop condition	Writing "0" to A-D conversion start flag
Interrupt request generation timing	Not generated
Input pin	One of AN0 to AN7, as selected
Reading of result of A-D converter	Read A-D register corresponding to selected pin

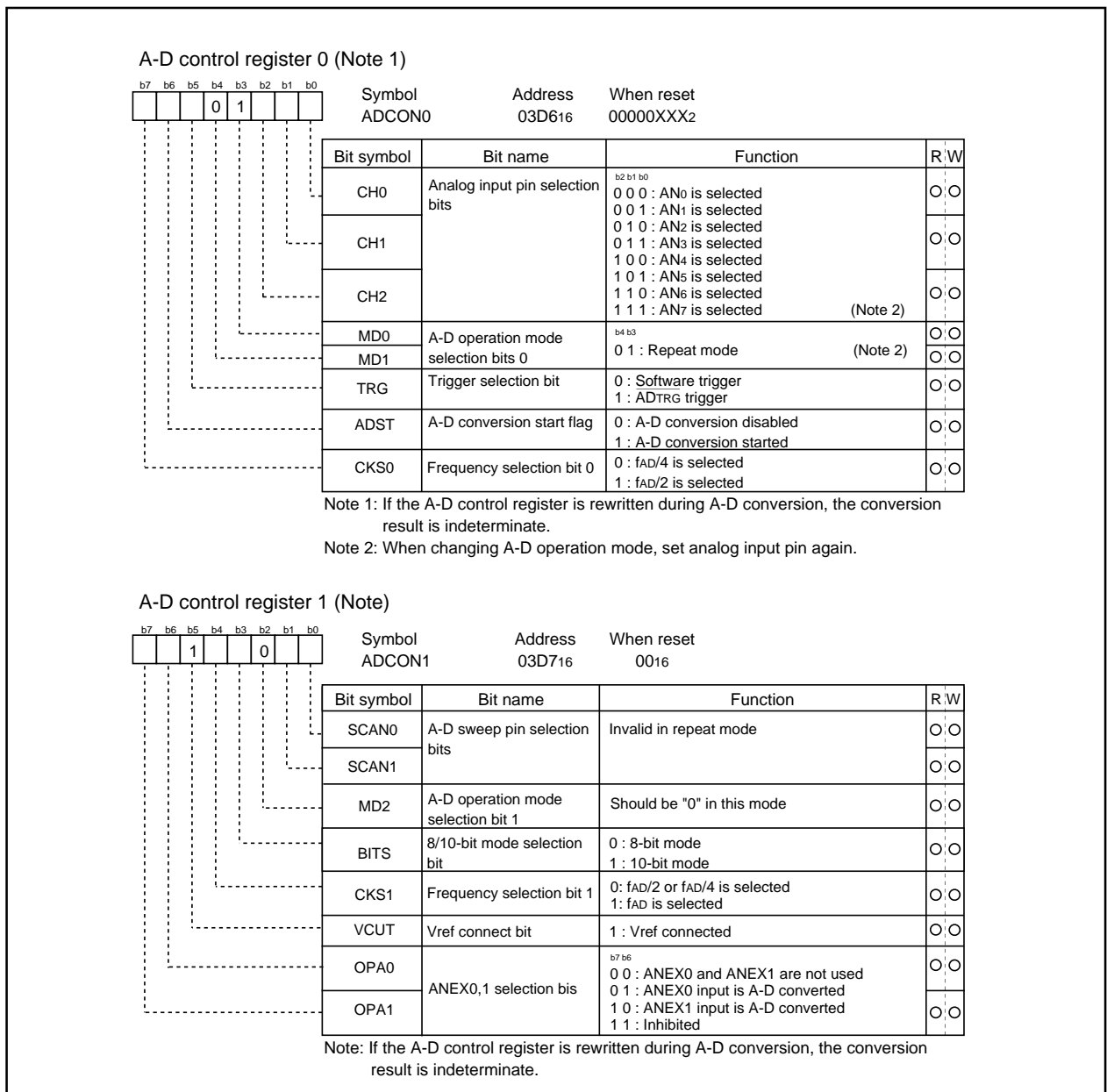

**Fig.JA-5 A-D conversion register in repeat mode**

### (3) Single sweep mode

In single sweep mode, the pins selected using the A-D sweep pin selection bits are used for one-by-one A-D conversion. Table.JA-4 shows the specifications of single sweep mode. Fig.JA-6 shows the A-D control register in single sweep mode.

**Table.JA-4 Single sweep mode specifications**

Item	Specification
Function	The pins selected by the A-D sweep pin selection bits are used for one-by-one A-D conversion
Start condition	Writing "1" to A-D converter start flag
Stop condition	<ul style="list-style-type: none"> <li>End of A-D conversion (A-D conversion start flag changes to "0", except when external trigger is selected)</li> <li>Writing "0" to A-D conversion start flag</li> </ul>
Interrupt request generation timing	End of A-D conversion
Input pin	AN <sub>0</sub> and AN <sub>1</sub> (2 pins), AN <sub>0</sub> to AN <sub>3</sub> (4 pins), AN <sub>0</sub> to AN <sub>5</sub> (6 pins), or AN <sub>0</sub> to AN <sub>7</sub> (8 pins)
Reading of result of A-D converter	Read A-D registers corresponding to selected pins

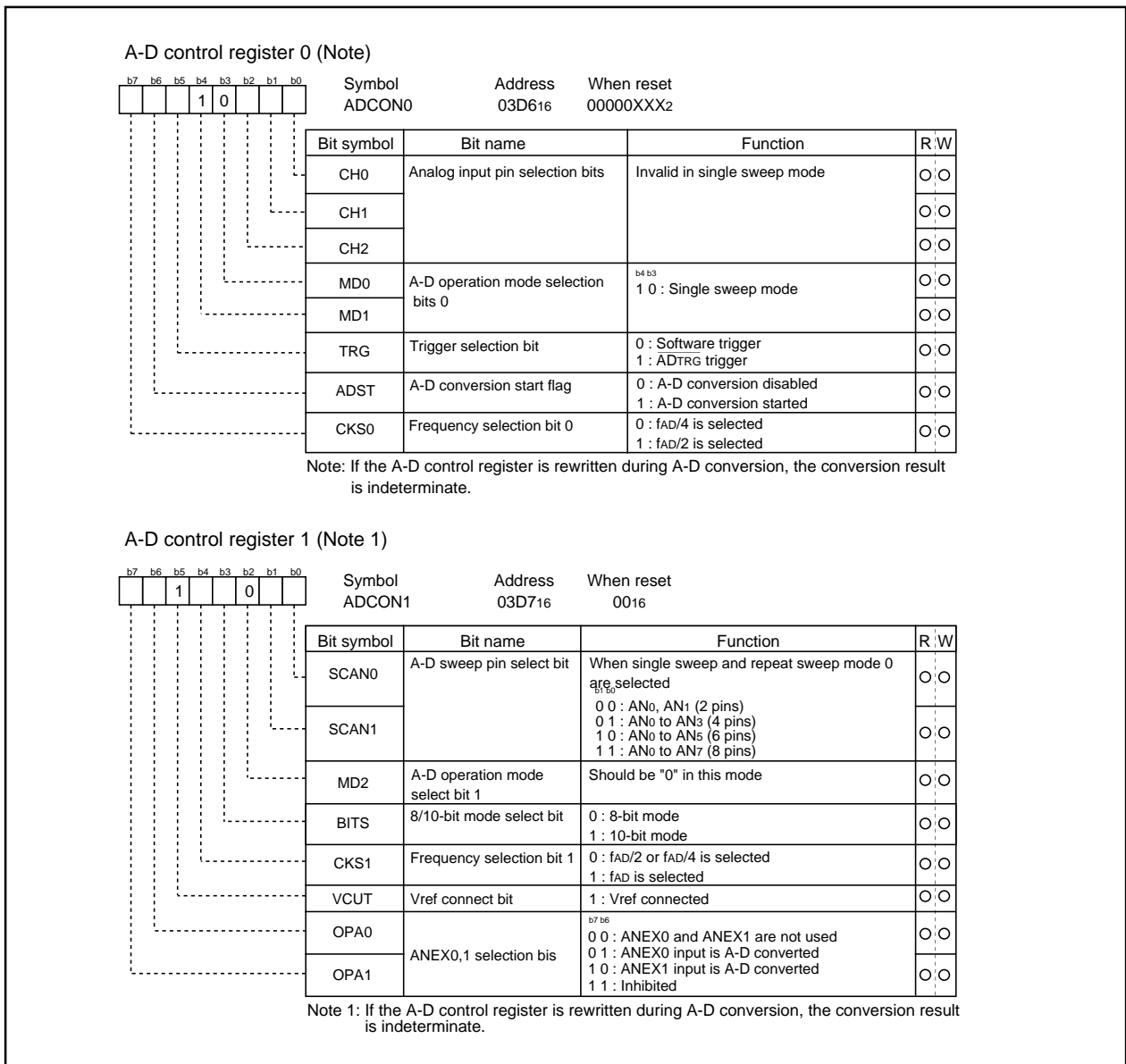

**Fig.JA-6 A-D conversion register in single sweep mode**

**(4) Repeat sweep mode 0**

In repeat sweep mode 0, the pins selected using the A-D sweep pin selection bits are used for repeat sweep A-D conversion. Table.JA-5 shows the specifications of repeat sweep mode 0. Fig.JA-7 shows the A-D control register in repeat sweep mode 0.

**Table.JA-5 Repeat sweep mode 0 specifications**

Item	Specification
Function	The pins selected by the A-D sweep pin selection bits are used for repeat sweep A-D conversion
Start condition	Writing "1" to A-D conversion start flag
Stop condition	Writing "0" to A-D conversion start flag
Interrupt request generation timing	Not generated
Input pin	AN <sub>0</sub> and AN <sub>1</sub> (2 pins), AN <sub>0</sub> to AN <sub>3</sub> (4 pins), AN <sub>0</sub> to AN <sub>5</sub> (6 pins), or AN <sub>0</sub> to AN <sub>7</sub> (8 pins)
Reading of result of A-D converter	Read A-D registers corresponding to selected pins (at any time)

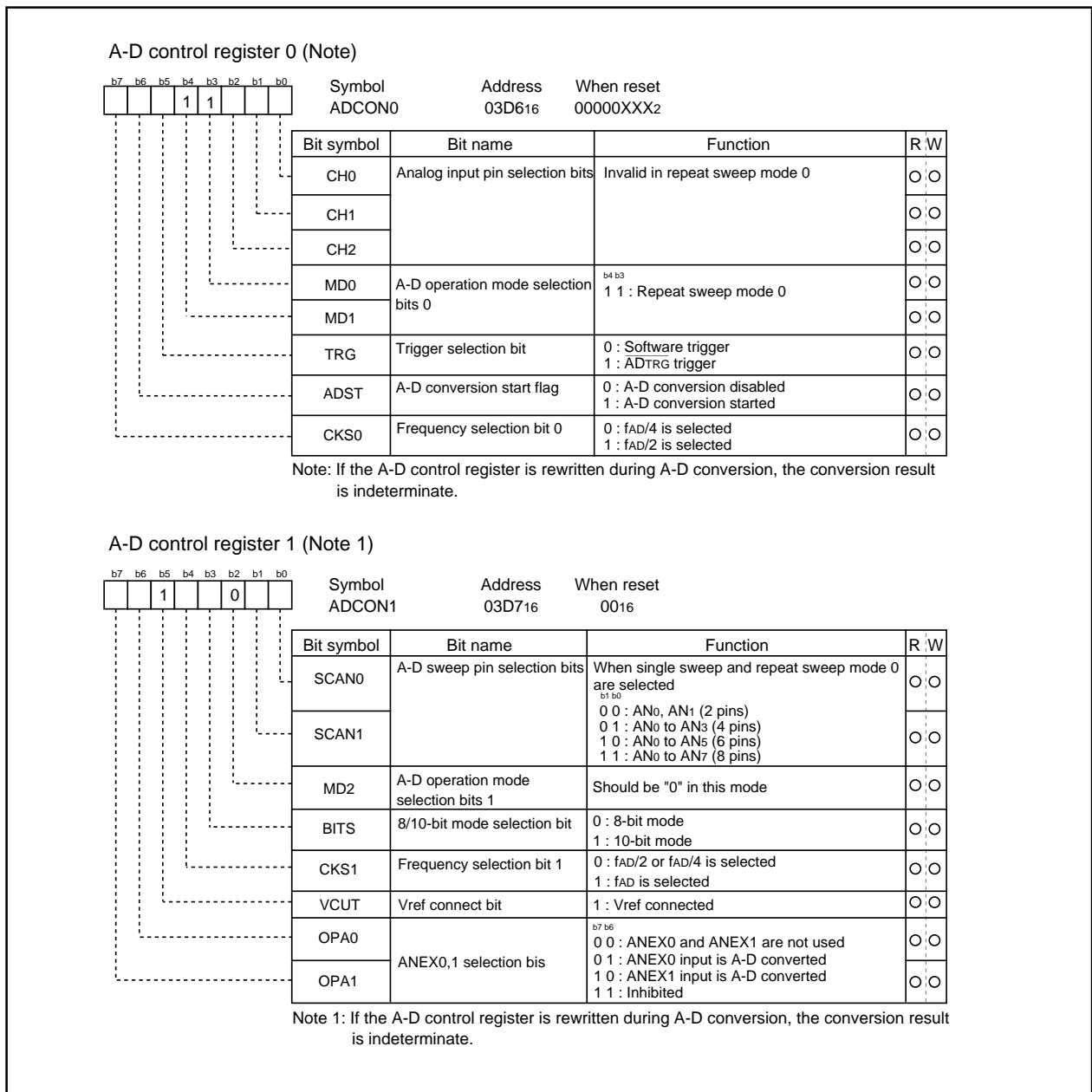

**Fig.JA-7 A-D conversion register in repeat sweep mode 0**

**(5) Repeat sweep mode 1**

In repeat sweep mode 1, all pins are used for A-D conversion with emphasis on the pin or pins selected using the A-D sweep pin selection bits. Table.JA-6 shows the specifications of repeat sweep mode 1. Fig.JA-8 shows the A-D control register in repeat sweep mode 1.

**Table.JA-6 Repeat sweep mode 1 specifications**

Item	Specification
Function	All pins perform repeat sweep A-D conversion, with emphasis on the pin or pins selected by the A-D sweep pin selection bits Example : AN <sub>0</sub> selected AN <sub>0</sub> → AN <sub>1</sub> → AN <sub>0</sub> → AN <sub>2</sub> → AN <sub>0</sub> → AN <sub>3</sub> , etc
Start condition	Writing "1" to A-D conversion start flag
Stop condition	Writing "0" to A-D conversion start flag
Interrupt request generation timing	Not generated
Input pin	AN <sub>0</sub> (1 pin), AN <sub>0</sub> and AN <sub>1</sub> (2 pins), AN <sub>0</sub> to AN <sub>2</sub> (3 pins), AN <sub>0</sub> to AN <sub>3</sub> (4 pins)
Reading of result of A-D converter	Read A-D registers corresponding to selected pins (at any time)

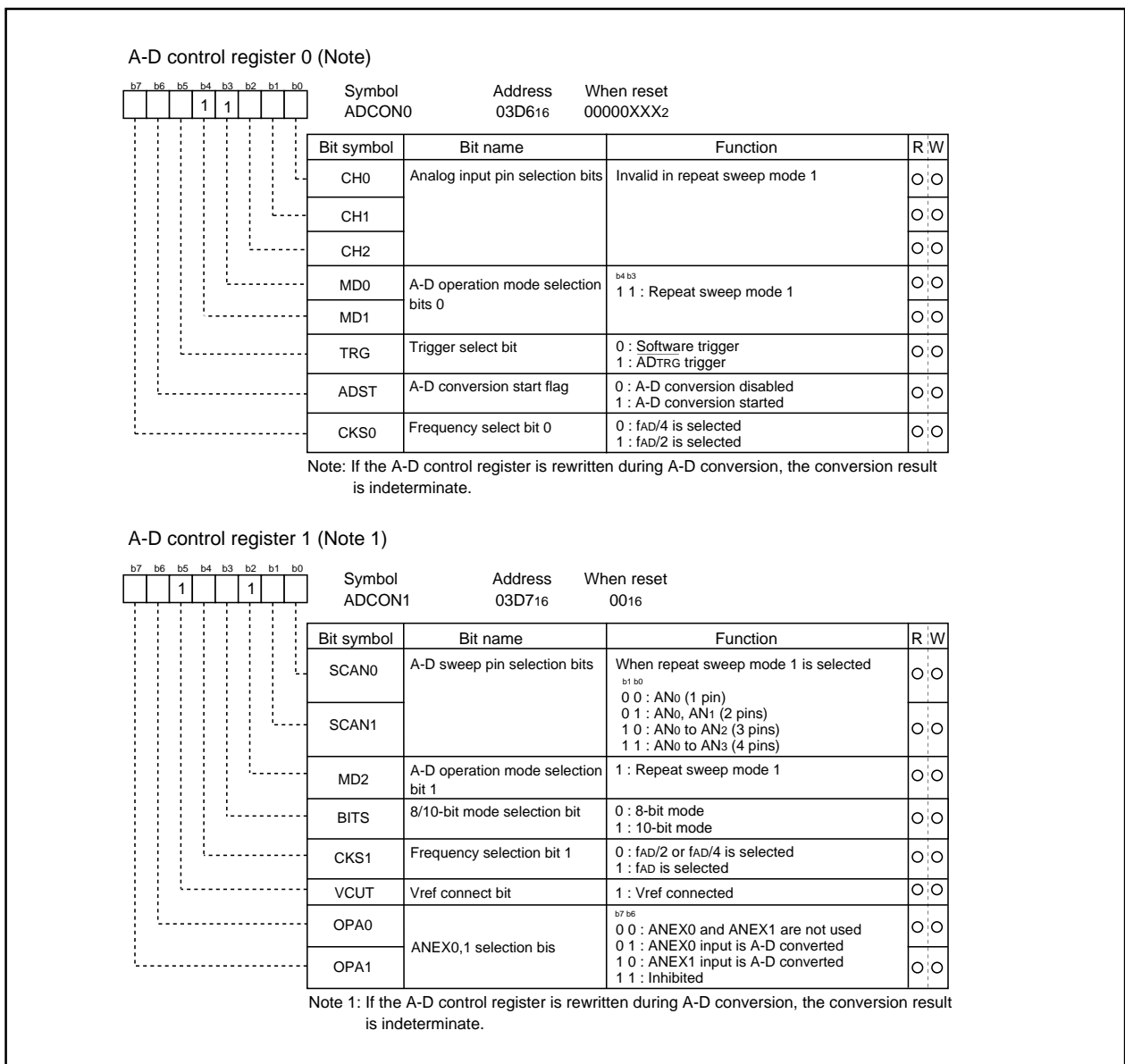

**Fig.JA-8 A-D conversion register in repeat sweep mode 1**

**(a) Sample and hold**

Sample and hold is selected by setting bit 0 of the A-D control register 2 (address 03D416) to "1". When sample and hold is selected, the range of conversion of each pin increases. As a result, a 28 fAD cycle is achieved with 8-bit resolution and 33fAD with 10-bit resolution. Sample and hold can be selected in all modes. However, in all modes, be sure to specify before starting A-D conversion whether sample and hold is to be used.

**(b) Extended analog input pins**

In one-shot mode and repeat mode, the input via the extended analog input pins ANEX0 and ANEX1 can also be converted from analog to digital.

When bit 6 of the A-D control register 1 (address 03D716) is "1" and bit 7 is "0", input via ANEX0 is converted from analog to digital. The result of conversion is stored in A-D register 0.

When bit 6 of the A-D control register 1 (address 03D716) is "0" and bit 7 is "1", input via ANEX1 is converted from analog to digital. The result of conversion is stored in A-D register 1.



**D-A Converter**

This is an 8-bit, R-2R type D-A converter. The microcomputer contains two independent D-A converters of this type.

DA conversion is performed when a value is written to the corresponding D-A register. Bits 0 and 1 (D-A output enable bits) of the D-A control register decide if the result of conversion is to be output. Do not set the corresponding port to output mode if D-A conversion is to be performed. If D-A output is enabled, the pull-up of corresponding port is inhibited.

Output analog voltage (V) is determined by a set value n (n : decimal) in the D-A register.

$$V = V_{REF} \times n / 256 \quad (n = 0 \text{ to } 255)$$

VREF : reference voltage

Table.JB-1 lists the performance of the D-A converter. Fig.JB-1 shows the block diagram of the D-A converter. Fig.JB-2 shows the D-A control register. Fig.JB-3 shows the D-A converter equivalent circuit.

**Table.JB-1 Performance of D-A converter**

Item	Performance
Conversion type	R-2R type
Resolution	8 bits
Analog output pins	2 channels

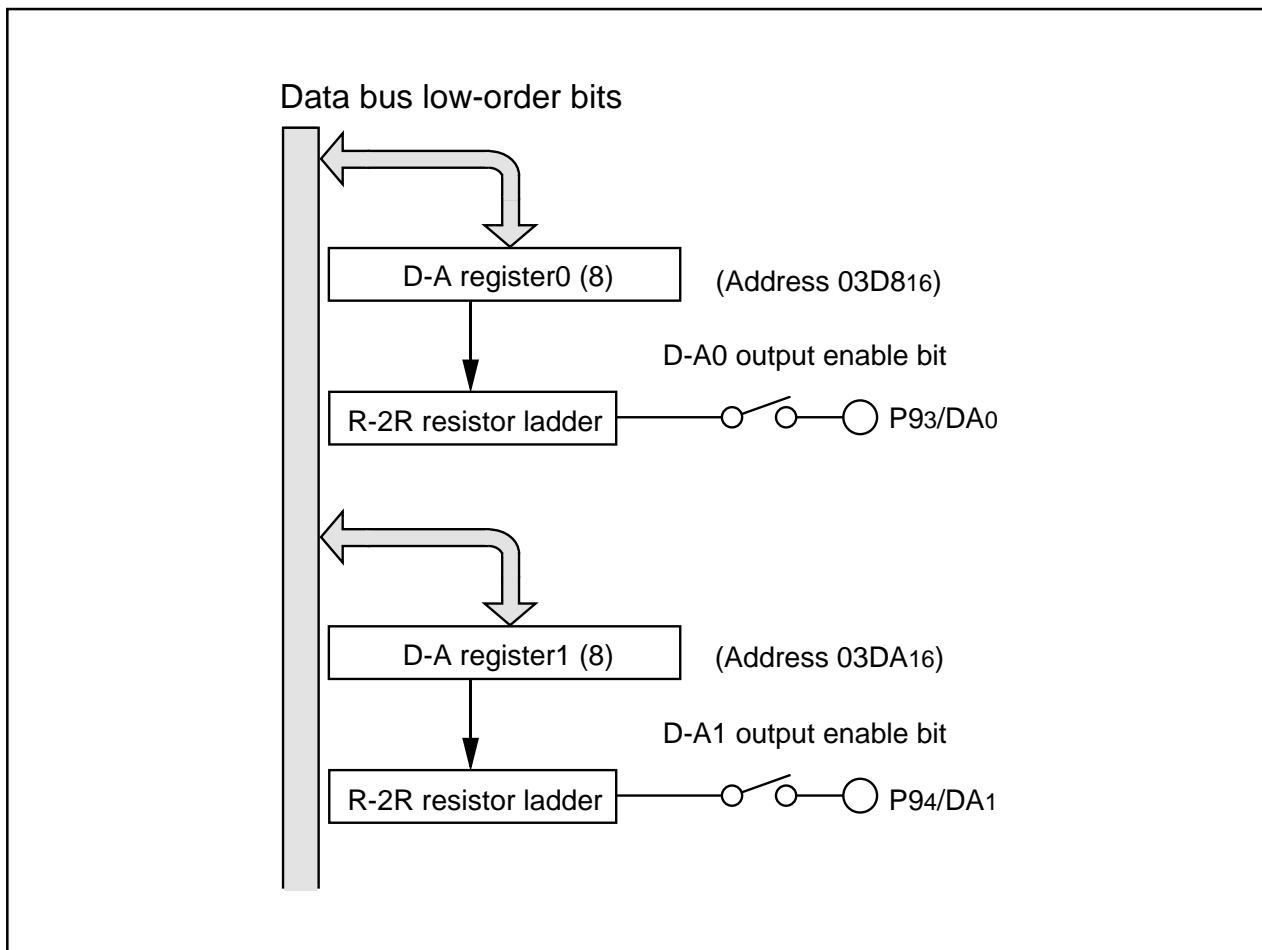

**Fig.JB-1 Block diagram of D-A converter**

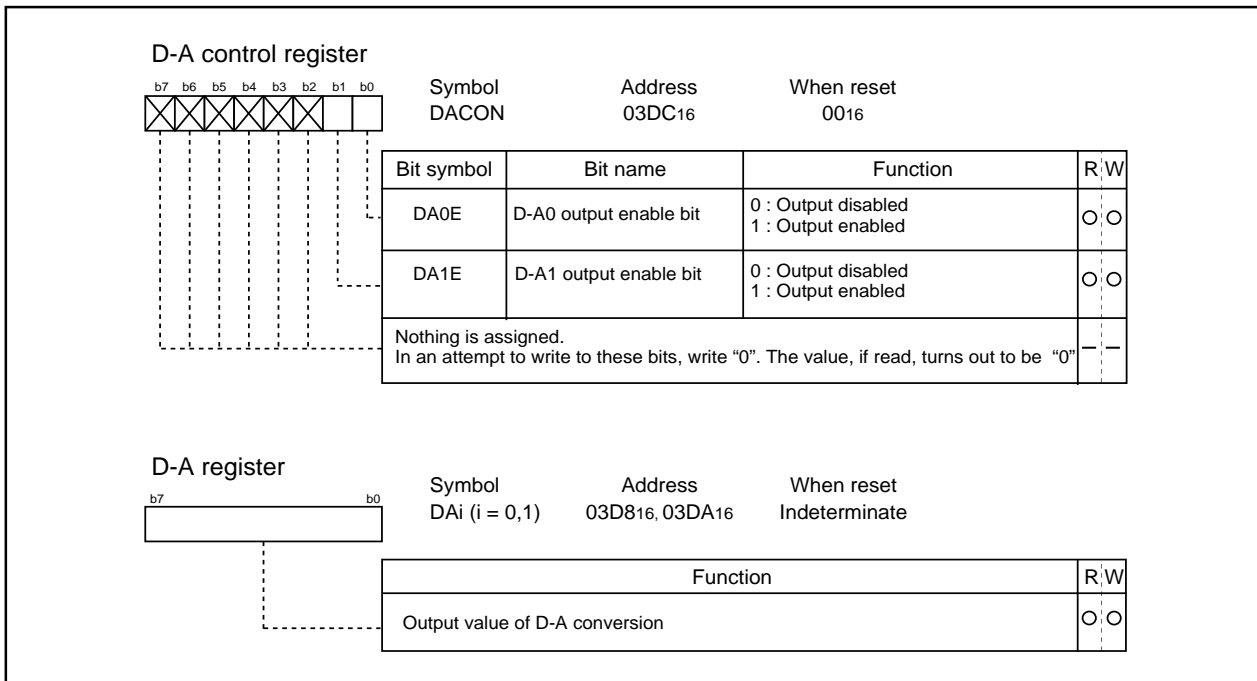

Fig.JB-2 D-A control register

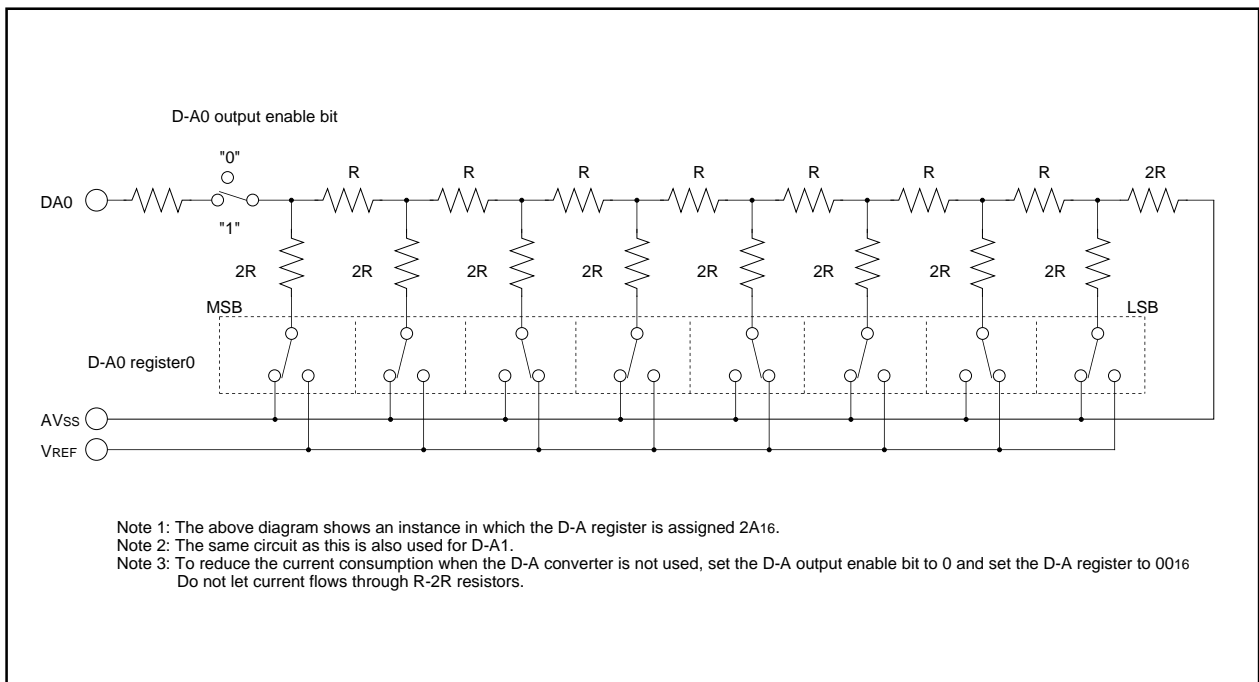

Fig.JB-3 D-A converter equivalent circuit

## Comparator Circuit

### Comparator Configuration

A comparator circuit consists of a switch tree, ladder resistance, comparators, comparator control circuit, the comparator control register (address 03DE16), comparator data register (address 03DF16), and analog signal input pins (P50 - P57). The analog input pins (P50 - P57) are shared with the usual digital port I/O pins.

The comparator control register is a 4-bit register and can generate internal analog voltages in steps of  $1/16 V_{cc}$  with the contents of bits 0 to 3. In Table.JC-2 contents of bits 0 to 3 of the comparator control register and corresponding internal analog voltage generated are indicated. The compared result of the analog input voltage and internal analog voltage is stored in the comparator data register. The value of comparator control register can not be read out.

### Comparator Operation

In order to perform comparator operation, first, set the port P5 direction register (address 03EB16) to "0", as P5 can be used as the analog input pins. Then write a digital value, which corresponds to the internal analog voltage to be compared, to bits 0 to 3 of the comparator control register (address 03DE16). The voltage comparison starts immediately by the writing operation. After 14 cycles of  $1/2$  main clock (the time needed for comparison), the compared result of the comparator is stored in the comparator data register (address 03DF16). Each bit of this register becomes as follows depending on the status of corresponding P50 to P57 pins:

When analog input voltage  $>$  internal analog voltage, it is "1".

When analog input voltage  $<$  internal analog voltage, it is "0".

For comparing once more, it is necessary to write data into comparator control register again even if the internal analog voltage is the same.

To read the result, wait 14 or more cycles after the comparator operation starts.

During the 14 cycles of the comparison, the ladder resistance is turned on and the reference voltage is generated. When the comparator is not in operation, the ladder resistance is off. Therefore, unnecessary consumption is prevented.

The comparison is accomplished by capacitive coupling. If the clock frequency is too low, electric charge will be lost. While the comparator is in operation, the clock frequency must be 1MHz or higher. During this time, do not execute a STP instruction, a WIT instruction, or an I/O instruction for port P5.

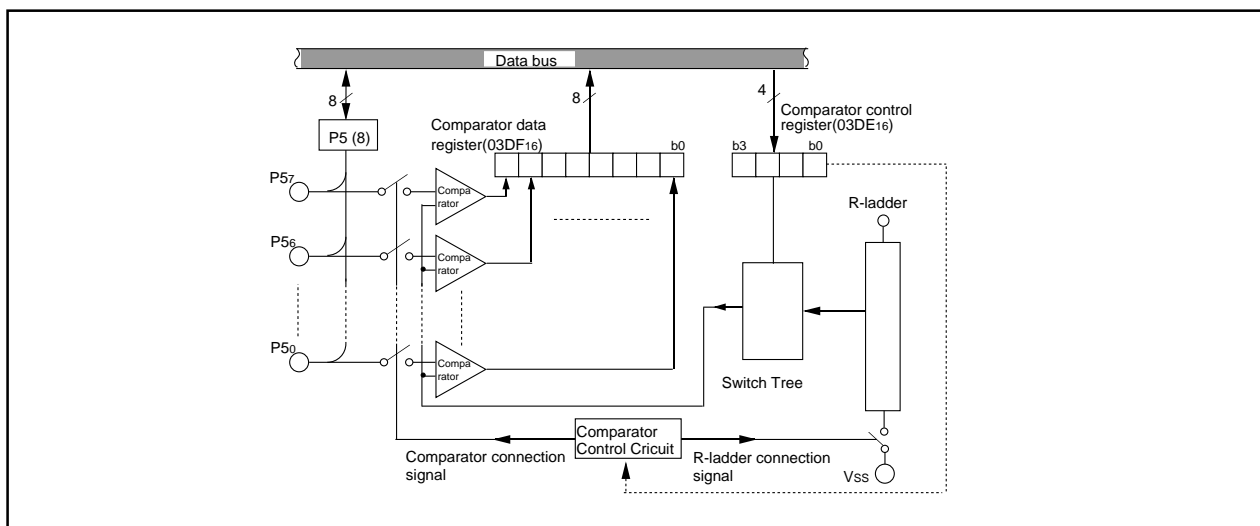
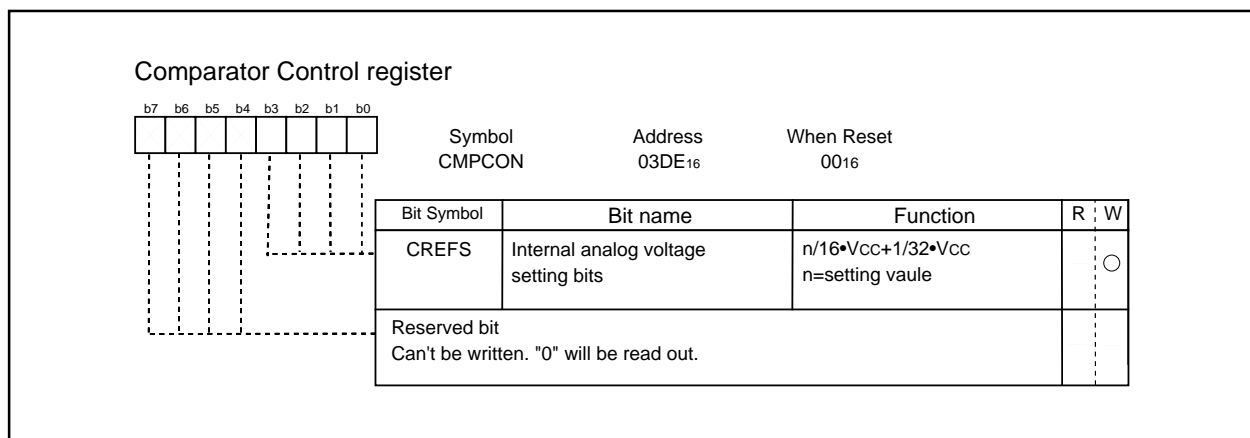

Fig.JC-1 Comparator circuit

**Table.JC-1 Correspondence of internal analog voltage and contents of bits 0 to 3 of the comparator control register.**

Comparator Control Register Contents of bit 0 to 3	Internal Analog Voltage
0 0 0 0                  LSB	$1 / 32 \cdot V_{cc}$
0 0 0 1	$1 / 16 \cdot V_{cc} + 1 / 32 \cdot V_{cc}$
0 0 1 0	$2 / 16 \cdot V_{cc} + 1 / 32 \cdot V_{cc}$
0 0 1 1	$3 / 16 \cdot V_{cc} + 1 / 32 \cdot V_{cc}$
0 1 0 0	$4 / 16 \cdot V_{cc} + 1 / 32 \cdot V_{cc}$
0 1 0 1	$5 / 16 \cdot V_{cc} + 1 / 32 \cdot V_{cc}$
0 1 1 0	$6 / 16 \cdot V_{cc} + 1 / 32 \cdot V_{cc}$
0 1 1 1	$7 / 16 \cdot V_{cc} + 1 / 32 \cdot V_{cc}$
1 0 0 0	$8 / 16 \cdot V_{cc} + 1 / 32 \cdot V_{cc}$
1 0 0 1	$9 / 16 \cdot V_{cc} + 1 / 32 \cdot V_{cc}$
1 0 1 0	$10 / 16 \cdot V_{cc} + 1 / 32 \cdot V_{cc}$
1 0 1 1	$11 / 16 \cdot V_{cc} + 1 / 32 \cdot V_{cc}$
1 1 0 0	$12 / 16 \cdot V_{cc} + 1 / 32 \cdot V_{cc}$
1 1 0 1	$13 / 16 \cdot V_{cc} + 1 / 32 \cdot V_{cc}$
1 1 1 0	$14 / 16 \cdot V_{cc} + 1 / 32 \cdot V_{cc}$
1 1 1 1	$15 / 16 \cdot V_{cc} + 1 / 32 \cdot V_{cc}$



**Fig.JC-2 Comparator control register**

### Pulse Width Modulation (PWM) Output Circuit

The M16C/6K group has four PWM output circuits, PWM0 to PWM3, with 14-bit resolution.

They operate independently. When the oscillation frequency  $X_{IN} = 8\text{MHz}$ , the minimum resolution bit width is 250 ns and the cycle period is 4096  $\mu\text{s}$ . The PWM timing generator supplies a PWM control signal based on the  $X_{IN}$  clock.

The following explanation assumes  $X_{IN} = 8\text{MHz}$ .

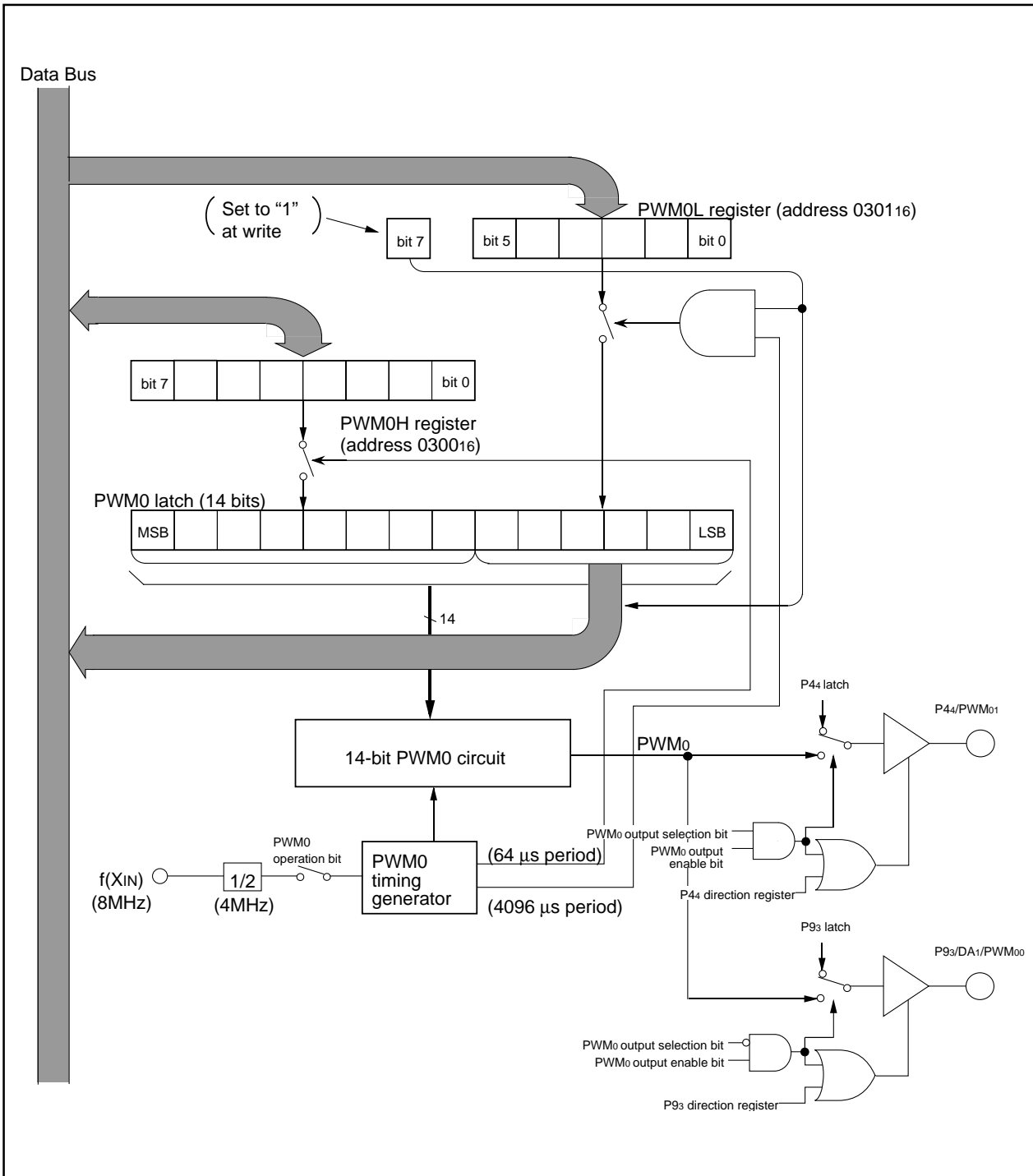

Fig.LA-1 PWM blobk diagram(PWM0)

## Data Setup (PWM0)

The PWM0 output pin shares with P93 or P44. The PWM0 output pin is selected from either P93/PWM00 or P44/PWM01 by bit 0 of PWM control register 0 (address 030816). The PWM0 output is enabled by setting bit 4 of PWM control register (address 030816) to "1". The PWM operation starts by setting bit 0 of PWM control register 1 (address 030916) to "1". The high-order eight bits of output data are set in the PWM0H register (address 030016) and the low-order six bits are set in the PWM0L register (address 030116). PWM1 to PWM3 is set as the same way.

## PWM Operation

The 14-bit PWM data is divided into the low-order six bits and the high-order eight bits in the PWM latch. The high-order eight bits of data determine how long an "H"-level signal is output during each sub-period. There are 64 sub-periods in each period, and each sub-period is  $256 \times \tau$  (64  $\mu$ s) long. The signal is "H" for a length equal to  $N$  times  $\tau$ , where  $\tau$  is the minimum resolution (250 ns). "H" or "L" of the bit in the ADD part shown in Fig. LA-2 is added to this "H" duration by the contents of the low-order 6-bit data according to the rule in Table.LA-1. That is, only in the sub-period  $t_m$  shown by Table.LA-1 in the PWM cycle period  $T = 64t$ , its "H" duration is lengthened to the minimum resolution  $\tau$  added to the length of other periods.

For example, if the high-order eight bits of the 14-bit data are 0316 and the low-order six bits are 0516, the length of the "H"-level output in sub-periods  $t_8$ ,  $t_{24}$ ,  $t_{32}$ ,  $t_{40}$ , and  $t_{56}$  is  $4\tau$ , and its length is  $3\tau$  in all other sub-periods. Time at the "H" level of each sub-period almost becomes equal, because the time becomes length set in the high-order 8 bits or becomes the value plus  $\tau$ , and this sub-period  $t$  (= 64  $\mu$ s approximate 15.6 kHz) becomes cycle period approximately.

## Transfer From Register to Latch

Data written to the PWML register is transferred to the PWM latch at each PWM period (every 4096  $\mu$ s) and data written to the PWMH register is transferred to the PWM latch at each sub-period (every 64  $\mu$ s). The signal which is output to the PWM output pin corresponds to the contents of this latch. A read from the PWML gets the latch content. However, bit 7 of the PWML register indicates whether the transfer to the PWM latch is completed; the transfer is completed when bit 7 is "0" and it is not done when bit 7 is "1."

Table.LA-1 Relationship between low-order 6 bits of data and period set by the ADD bit.

Low-order 6 bits of data (PWML)	Sub-periods $t_m$ Lengthened ( $m=0$ to 63)
0 0 0 0 0 0 LSB	None
0 0 0 0 0 1	$m=32$
0 0 0 0 1 0	$m=16,48$
0 0 0 1 0 0	$m=8,24,40,56$
0 0 1 0 0 0	$m=4,12,20,28,36,44,52,60$
0 1 0 0 0 0	$m=2,6,10,14,18,22,26,30,34,38,42,46,50,54,58,62$
1 0 0 0 0 0	$m=1,3,5,7, \dots, 63$

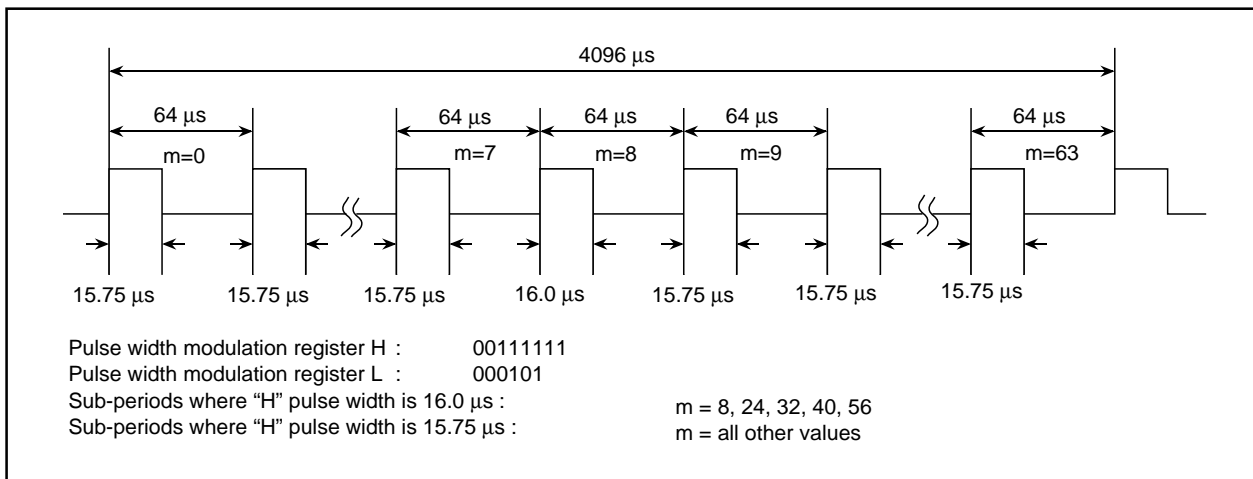

**Fig.LA-2 PWM timing**

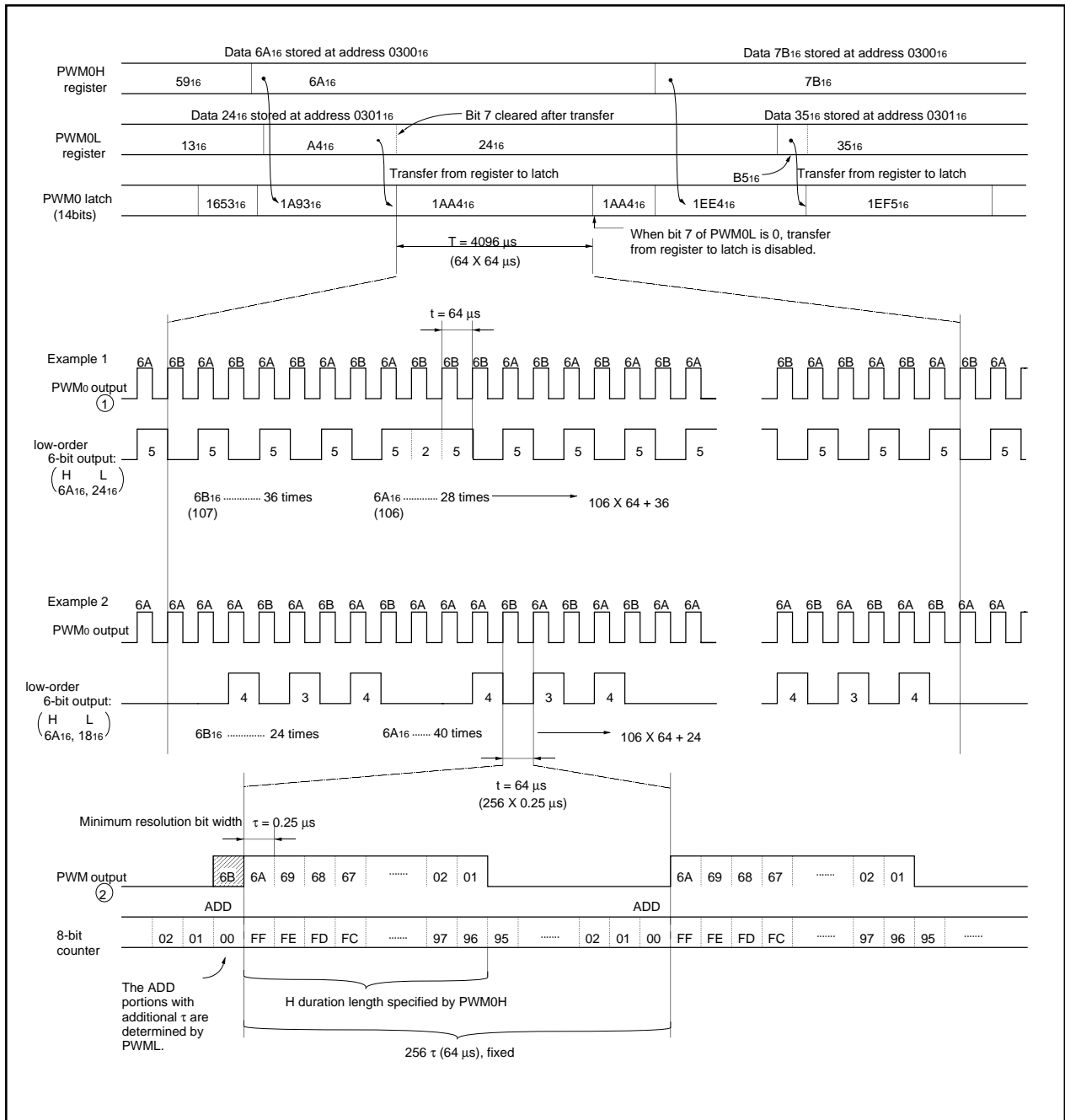

Fig.LA-3 14-bit PWM timing (PWM0)



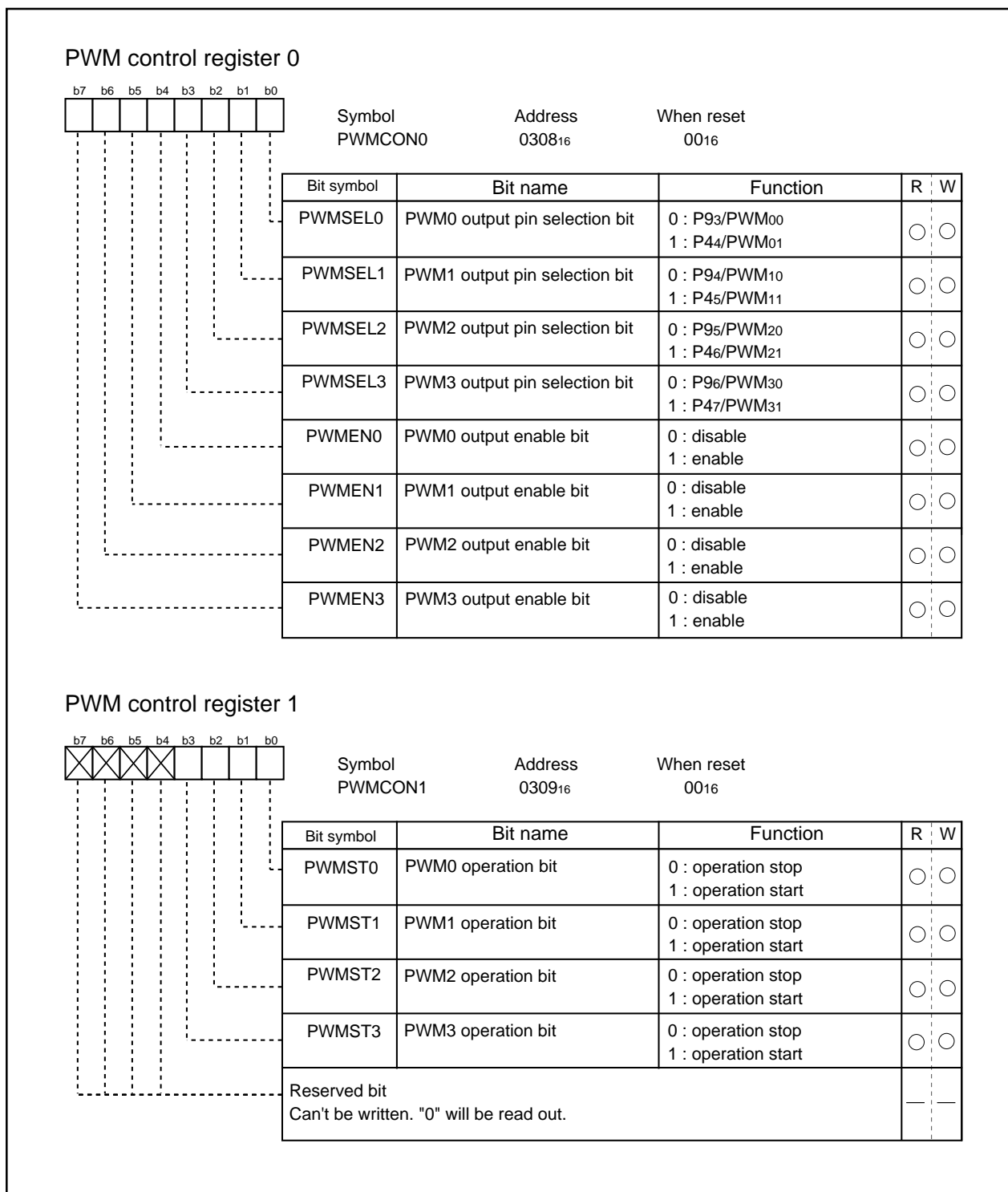

Fig.LA-4 PWM control registers

## LPC Bus Interface

LPC bus interface is based on Intel Low Pin Count (LPC) Interface Specification, Revision 1.0. It is I/O cycle data transfer format of serial communication. 4 channels are built in. The function of data bus buffer and data bus buffer status are almost the same as that of MELPS8-41 series. It can be written in or read out (as slave mode) by the control signals from host CPU side. The LPC bus interface functionality block diagram is shown in Figure GF-2. LPC data bus buffer functional Input / Output ports (P30-P36) are shared with GPIO port. The setting of bit3 (LPC bus buffer enable bit) of LPC control register (02D6<sub>16</sub>) is as below:

0: General purpose Input / Output port

1: LPC bus buffer functional Input / Output port

The enabling of channel of LPC bus buffer is controlled by bits 4-7 (LPC bus buffer 0-3 enable bits) of LPC control register (02D6<sub>16</sub>). The slave address (16 bits) of LPC bus buffer channel 0 is fixed on 0060h, 0064h. The slave addresses (16 bits) of LPC bus buffer channel 1-3 are definable by setting LPC 1-3 address register H, L (02D0<sub>16</sub> to 02D5<sub>16</sub>). The setting value of bit2 of LPC1-3 address register (A2) L will not be decoded. The bit is "0" when read from slave CPU. The A2 status of slave address is latched to XA2 flag when written by host CPU. The input buffer full interrupt is generated when written in the data by host CPU. The Output buffer empty interrupt is generated when read out the data by host CPU. As shown in GF-1, the input buffer full interrupt request and output buffer empty interrupt request are switched by bit6, 7 of ISA control register0.

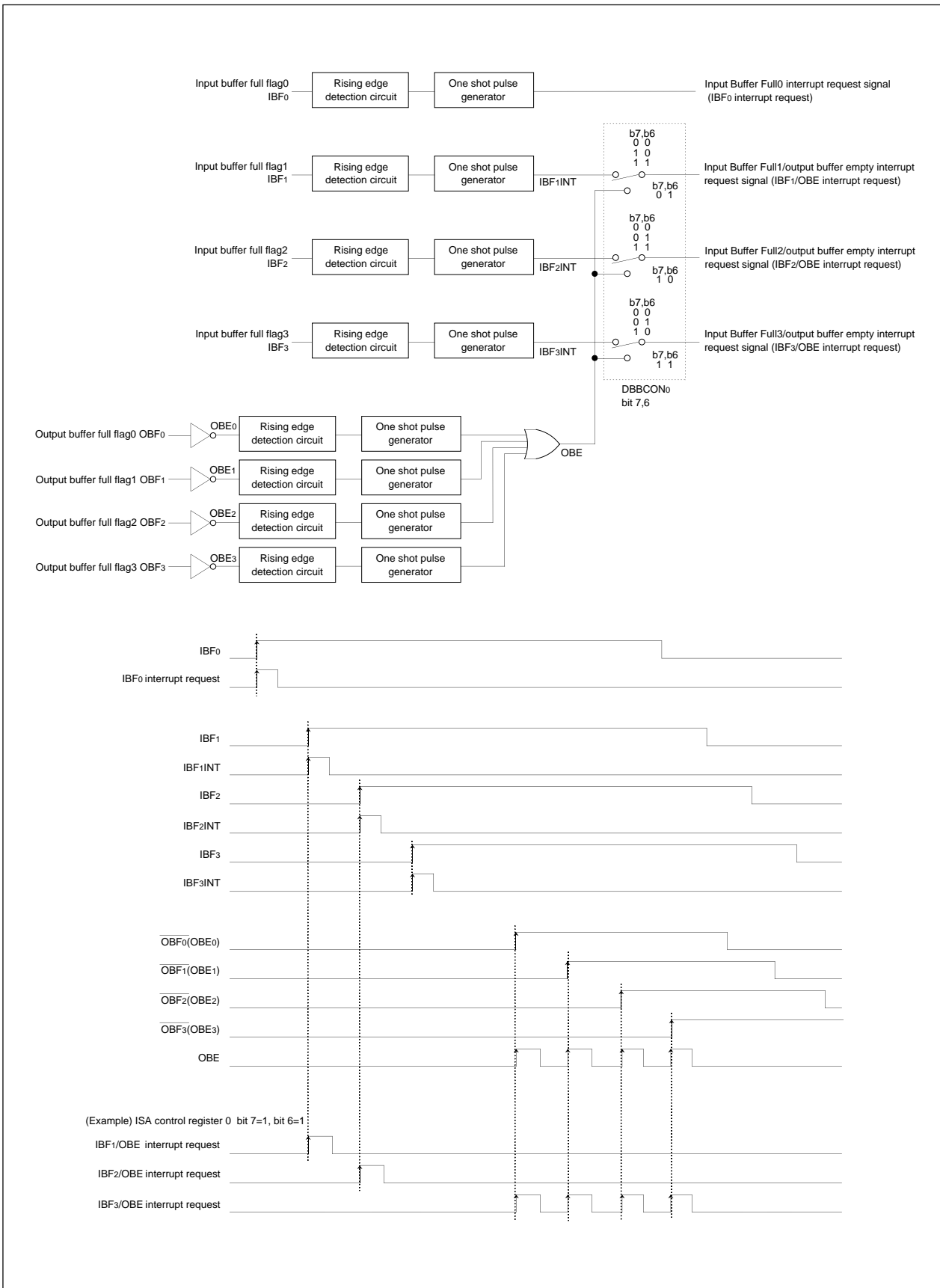

Fig.GF-1 Interrupt, request, circuit of Data Bus Buffer

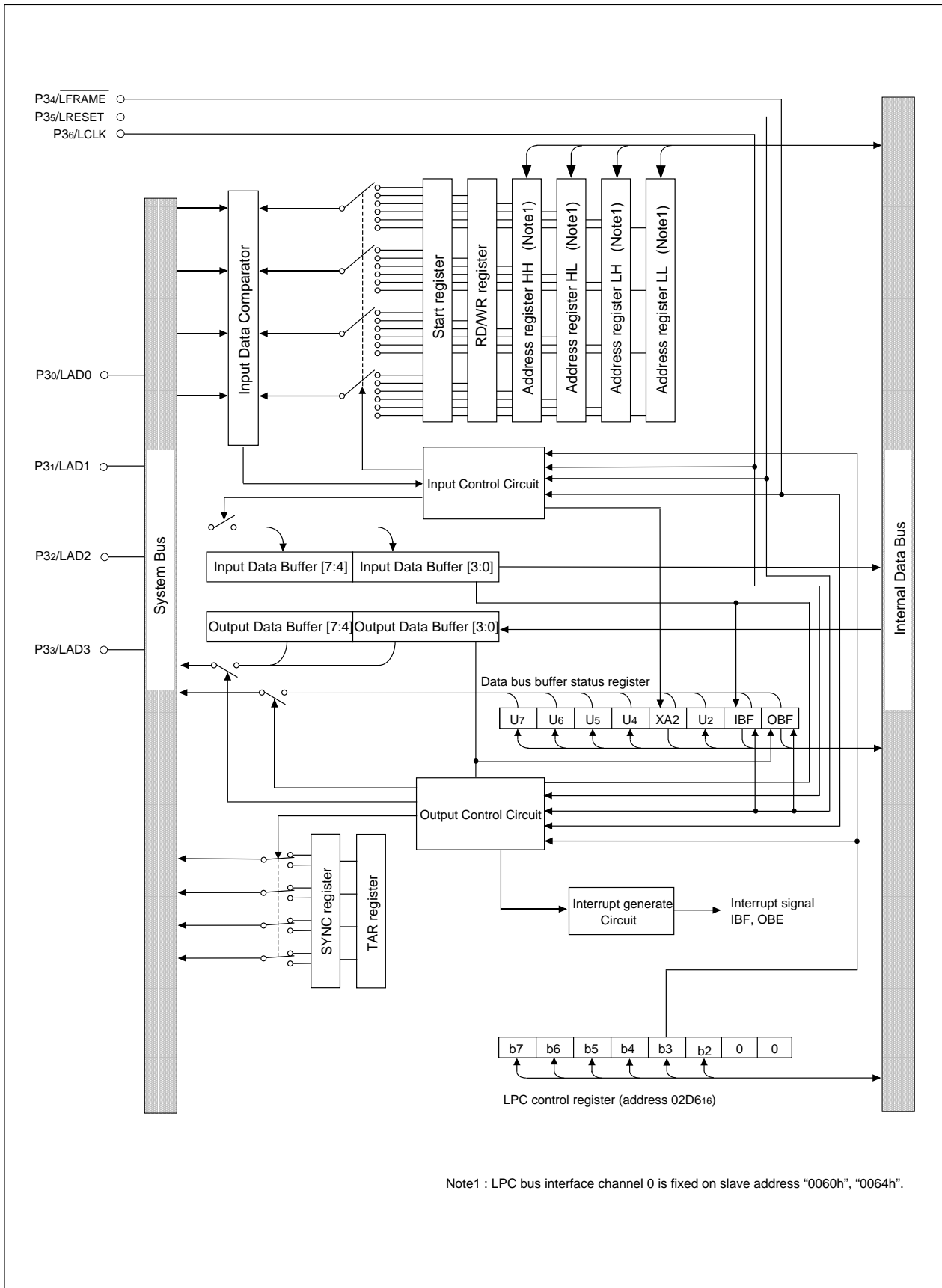

Fig.GF-2 LPC bus interface function block diagram (LPC1)

Figure GF-3: ISA control registers

Figure GF-4: Data bus buffer status register

Figure GF-5, 6: LPC related registers

### **Data bus buffer status register (DBBSTS0-DBBSTS3)**

This is 8-bit register.

The bit 0, 1, 3 are read only bits and indicate the status of data bus buffer.

Bit 2, 4, 5, 6, 7 are user definable and flags which can be read and written by software. The data bus buffer status register can be read out by host CPU when the slave address (16 bit) bit2 (A2) is high.

- Output buffer full flag (OBF)

The bit will be set to "1" when a data is written into output data bus buffer and will be cleared to "0" when host CPU read out the data from output data bus buffer.

- Input buffer full flag (IBF)

The bit will be set to "1" while a data is written into input data bus buffer by host CPU and will be cleared to "0" when the data is read out from input data bus buffer by slave CPU.

- XA2 flag (XA2)

The bit 2 of slave address (16 bits) is latched while a data is written into data bus buffer.

### **Input data bus buffer register (DBBIN0-DBBIN3)**

When there is a write request from host CPU, the data on the data bus will be latched to DBBIN0-3. The data of DBBIN0-3 can be read out from data bus buffer registers (Address: 02C0<sub>16</sub>, 02C2<sub>16</sub>, 02C4<sub>16</sub>, 02C6<sub>16</sub>) in SFR field.

### **Output data bus buffer register (DBBOUT0-DBBOUT3)**

When writing data to data bus buffer registers (Address: 02C0<sub>16</sub>, 02C2<sub>16</sub>, 02C4<sub>16</sub>, 02C6<sub>16</sub>), the data will be transferred to DBBOUT0-3 automatically. The data of DBBOUT0-3 will be output to the data bus when there is a read request from host CPU and the status of bit2 (A2) of slave address (16 bits) is low.

### **LPCi address register H/L (LPC1ADH-LPC3ADH / LPC1ADL-LPC3ADL)**

The slave address (16 bits) of LPC bus buffer channel 0 is fixed on 0060h, 0064h.

The slave addresses (16 bits) of LPC bus buffer channel 1-3 are definable by setting LPC1-3 address registers H/L (02D0<sub>16</sub> to 02D5<sub>16</sub>). The settings are for slave address upper 8 bits and lower 8 bits. And these registers can be set and cleared in any time.

The bit 2 of LPC 1-3 address L is not decoded regardless of the setting value. When slave CPU reads LPC1-3 address registers, the bit2 (A2) of address low byte will be fixed to "0". The bit2 (A2) status of slave address is latched to XA2 flag when written by host CPU. The slave addresses that are already set in these registers will be used for comparing with the addresses to be received.

**LPC control register (LPCCON)**

- LPC bus interface enable bit (LPCBEN)
  - "0": P30 -P36 use as GPIO
  - "1": P30 -P36 use as LPC bus interface
- LPC bus buffer 0 enable bit (LPCEN0)
  - "0": LPC bus buffer0 disable
  - "1": LPC bus buffer0 enable
- LPC bus buffer 1 enable bit (LPCEN1)
  - "0": LPC bus buffer1 disable
  - "1": LPC bus buffer1 enable
- LPC bus buffer 2 enable bit (LPCEN2)
  - "0": LPC bus buffer2 disable
  - "1": LPC bus buffer2 enable
- LPC bus buffer 3 enable bit (LPCEN3)
  - "0": LPC bus buffer3 disable
  - "1": LPC bus buffer3 enable

- LPC software reset bit (LPCSR)

By setting the bit to "1", LPC interface is reset by the same status as  $\overline{\text{LRESET}}=\text{"L"}$ . After 1.5 cycles of BCLK at writing "1", reset is released and the bit becomes "0".

Nothing happens if "0" is set.

- SYNC output selection bits (SYNCSEL0, SYNCSEL1)

Table.GF-1 shows the content of SYNC output selected by SYNC output selection bits.

**Table GF-1 SYNC output**

SYNCSEL1	SYNCSEL0	SYNC cycle	SYNC output			
			1st cycle	2nd cycle	3rd cycle	4th cycle
0	0	1	0000 <sub>2</sub>	—	—	—
0	1	4	0110 <sub>2</sub>	0110 <sub>2</sub>	0110 <sub>2</sub>	0000 <sub>2</sub>
1	0	1	1010 <sub>2</sub>	—	—	—
1	1	4	0110 <sub>2</sub>	0110 <sub>2</sub>	0110 <sub>2</sub>	1010 <sub>2</sub>

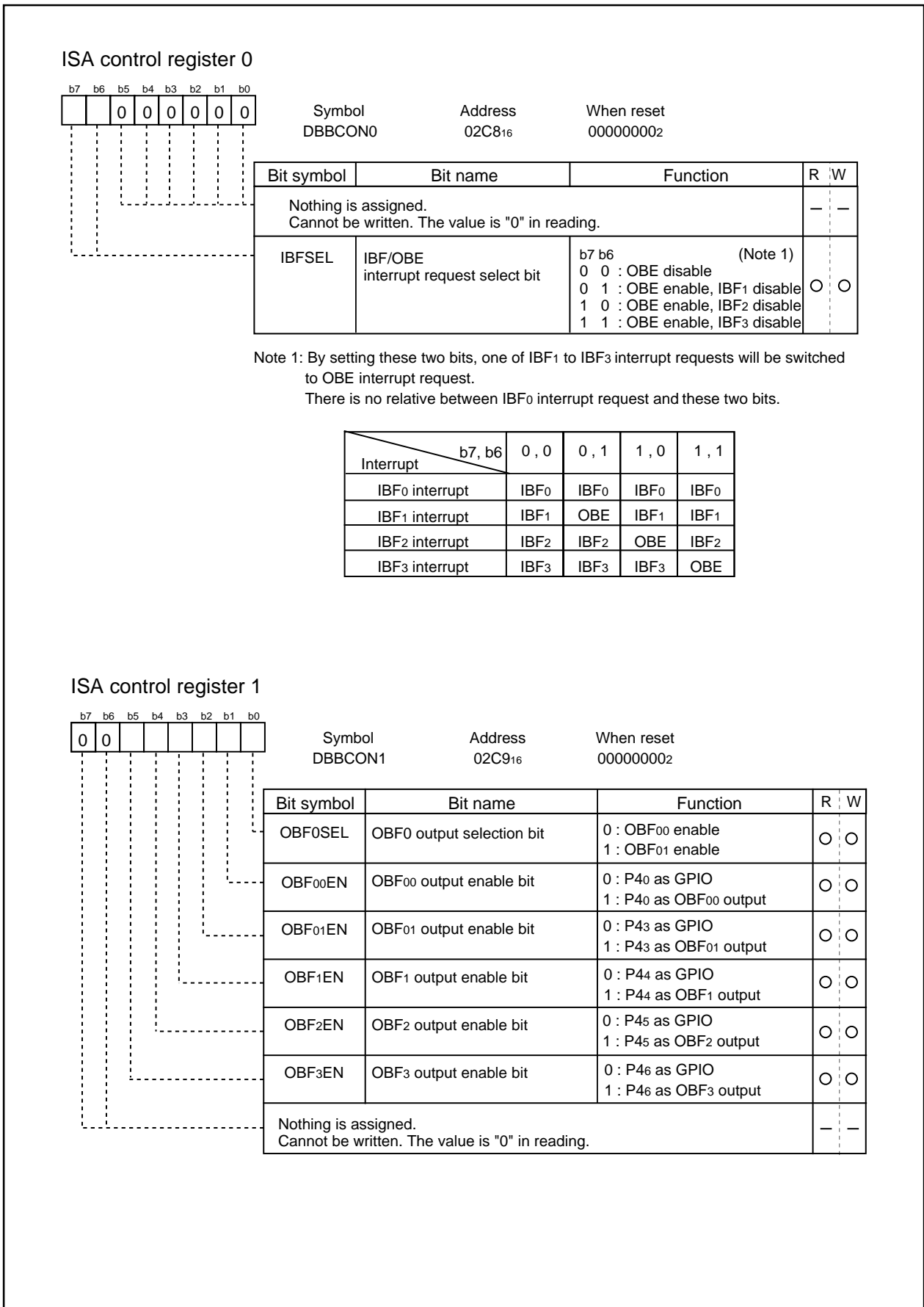

**Fig.GF-3 ISA control registers**

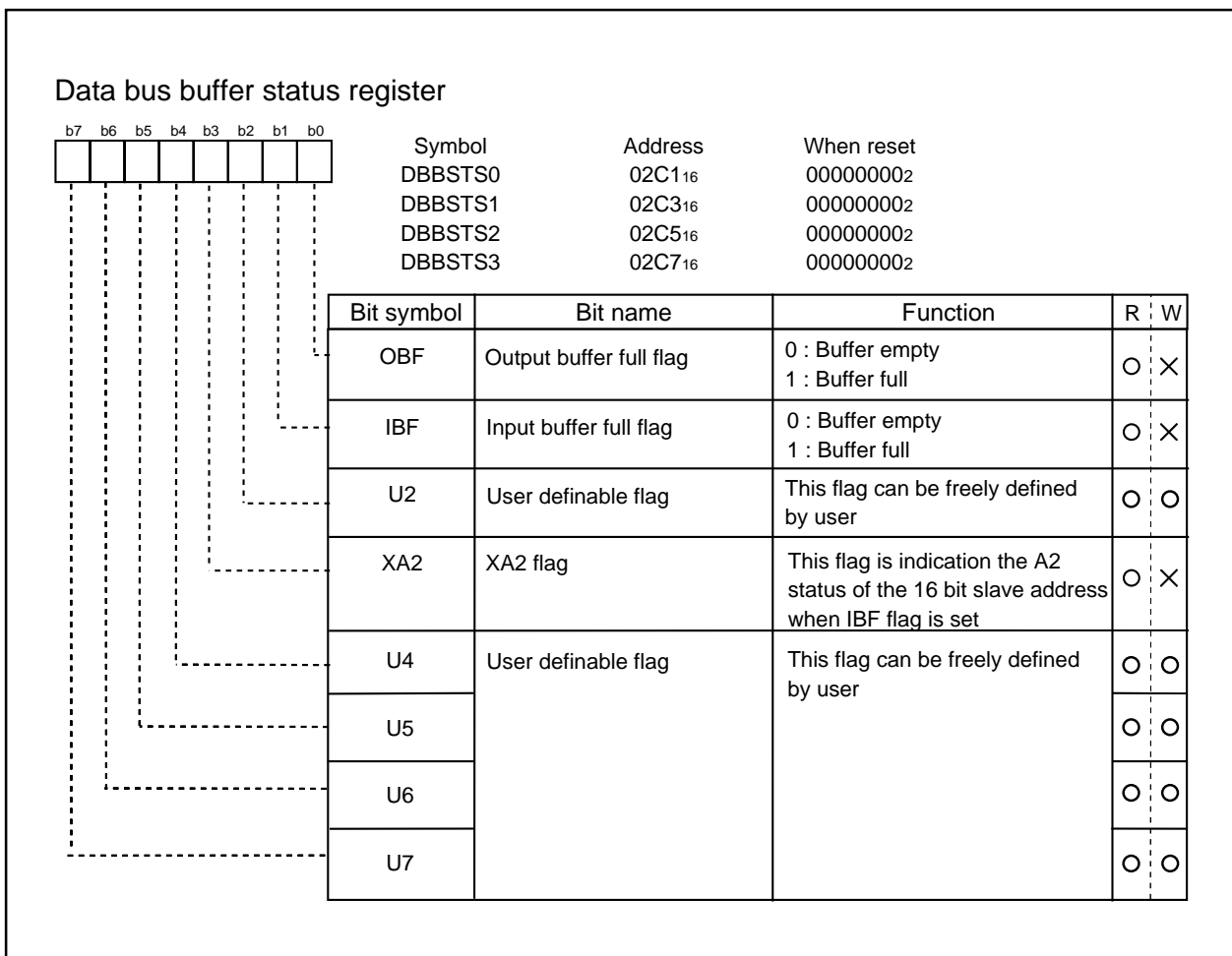

**Fig.GF-4 Data bus buffer status register**



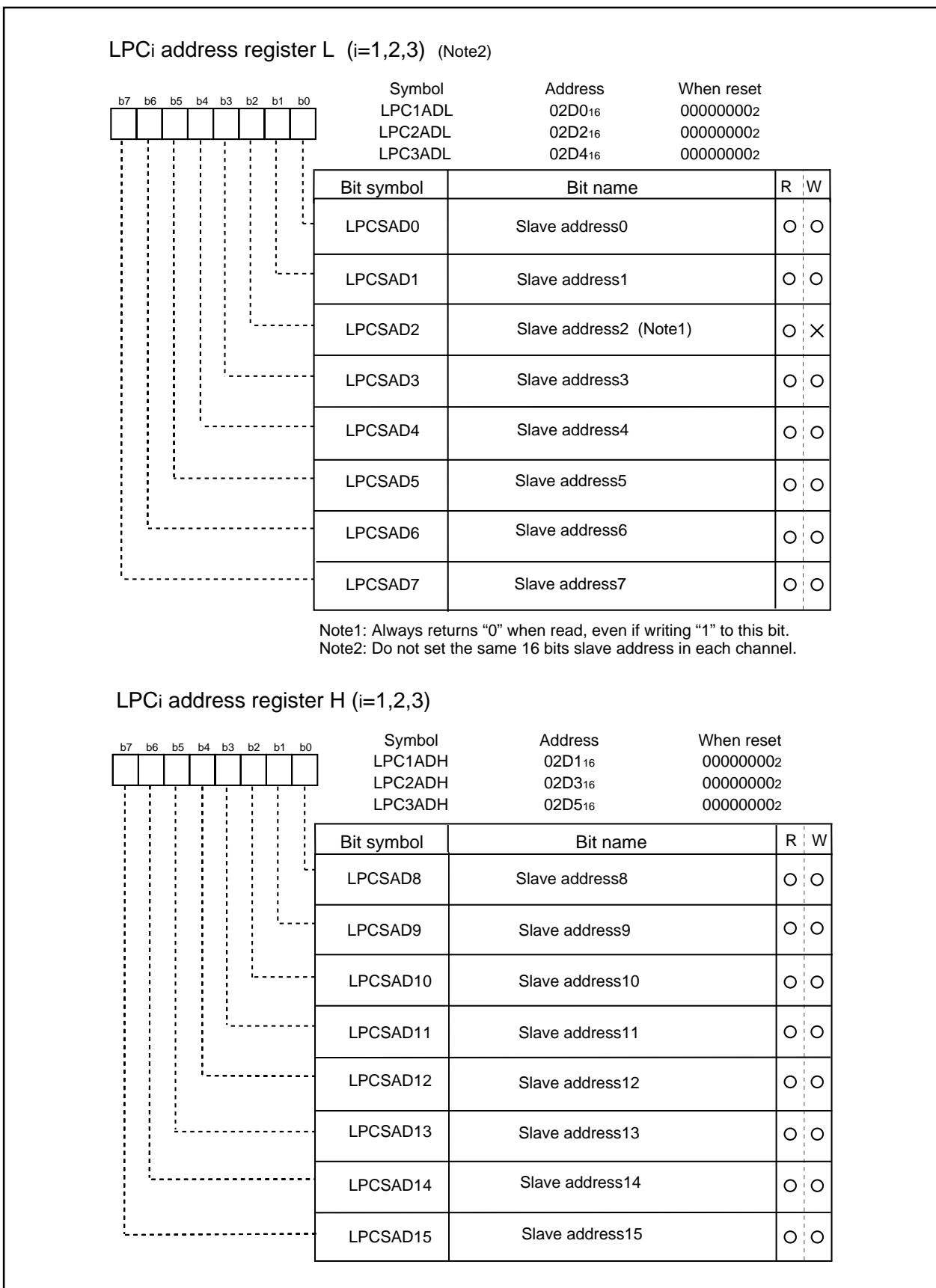
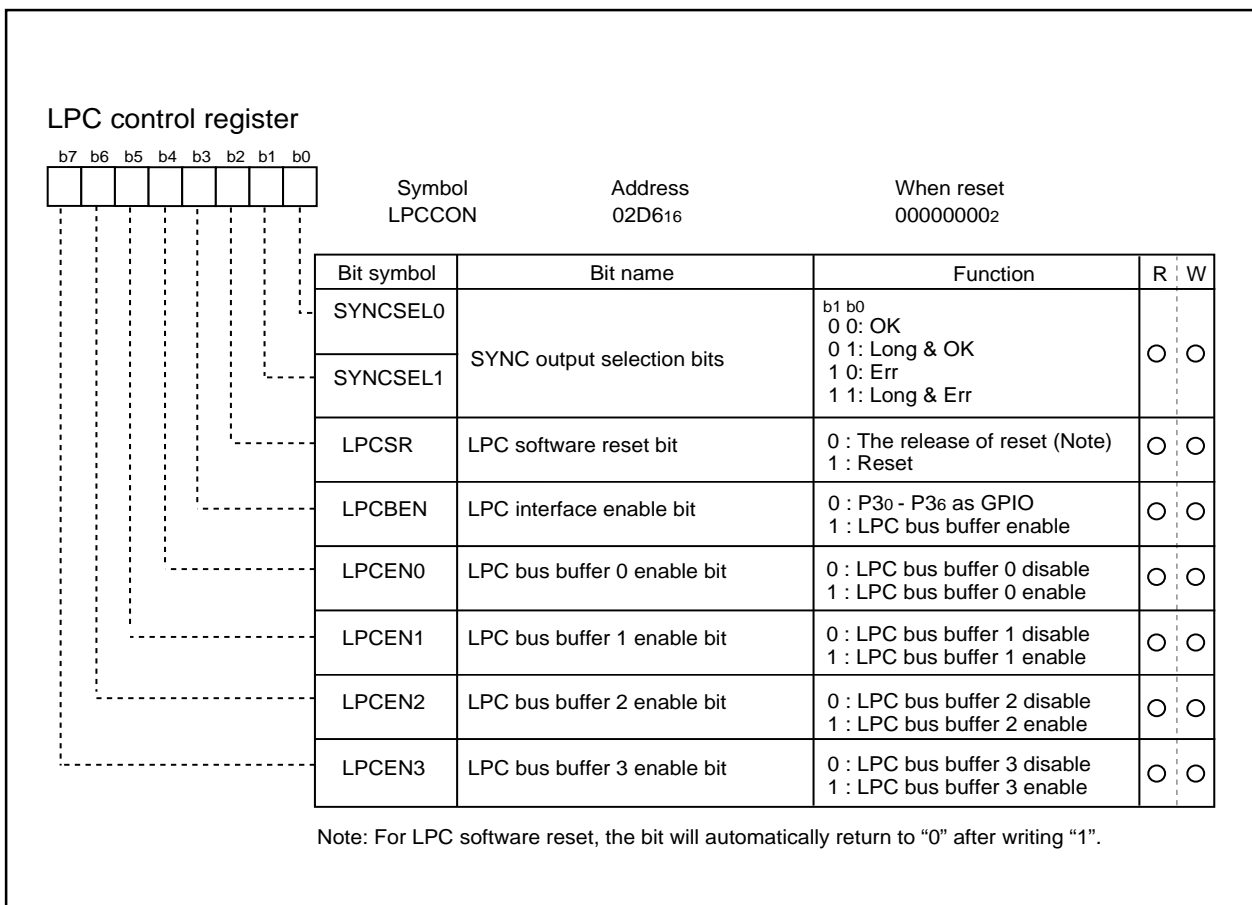

Fig.GF-5 LPC related registers



**Fig.GF-6** LPC control register

### Basic operation of LPC bus interface

The status transition of LPC bus interface is shown in Figure GF-7.

Setting steps for using LPC bus interface is explained below.

- Setting bit3 (LPC interface enable bit) of LPC control register(02D616 ) to "1"
- Choosing which LPC bus buffer channel will be used
- Setting "1" to bits 4-7 (LPC bus buffer 0-3 enable bit) of LPC control register (02D616 ).
- The 16-bit slave address of LPC bus buffer channel is defined by writing 16-bit slave address to LPC 1-3 address registers (02D016 - 02D516 ). If channel 1-3 LPC bus buffer is chosen, set the address to the corresponding address register.
- Selecting IBF/ OBE interrupt in ISA control register0 (02C816 )
- Selecting OBF output port in ISA control register1 (02C916 )

<1> Example of I/O writing cycle from HOST

Writing timing is shown in Figure GF-8.

The basic communication cycles of LPC I/O protocol are 13 cycles. The data of LAD[3:0] will be read by the rising edge of LCLK. Communication will start from  $\overline{\text{LFRAME}}$  falling edge.

- 1<sup>st</sup> cycle : When  $\overline{\text{LFRAME}}$  is "Low", sending "00002 " to LAD[3:0] for communication start frame detecting.
- 2<sup>nd</sup> cycle : When  $\overline{\text{LFRAME}}$  is "High", sending "001X2 " to LAD[3:0] for write frame detecting.
- From 3<sup>rd</sup> cycle to 6<sup>th</sup> cycle: These four cycles are detecting for 16 bits slave address.
  - 3<sup>rd</sup> cycle: The slave address which is from host is written to slave address register [15:12] through LAD[3:0]
  - 4<sup>th</sup> cycle: The slave address which is from host is written to slave address register [11:8] through LAD[3:0]
  - 5<sup>th</sup> cycle: The slave address which is from host is written to slave address register [7:4] through LAD[3:0]
  - 6<sup>th</sup> cycle: The slave address which is from host is written to slave address register [3:0] through LAD[3:0]
- 7<sup>th</sup> and 8<sup>th</sup> cycles are used for one data byte transfer.
  - 7<sup>th</sup> cycle: The data which is from host is written to input data buffer[3:0] through LAD[3:0]
  - 8<sup>th</sup> cycle: The data which is from host is written to input data buffer[7:4] through LAD[3:0]
- 9<sup>th</sup> and 10<sup>th</sup> cycles are for changing the communication direction from host→slave to slave→host
  - 9<sup>th</sup> cycle: Host outputs "11112 " to LAD[3:0]
  - 10<sup>th</sup> cycle: The LAD[3:0] will be set to Hi-Z by HOST to switch the communication direction.
- 11<sup>th</sup> cycle: The "00002 " (SYNC OK) is output to LAD[3:0] for acknowledge.
- 12<sup>th</sup> cycle: The "11112 " is output to LAD[3:0]. The XA2 and IBF flag are set. IBF interrupt signal is generated.
- 13<sup>th</sup> cycle: The LAD[3:0] will be set to Hi-Z by slave to switch the communication direction.

During the host write period, the bit2 (A2) status of 16 bits slave address will be latched to XA2 flag. When 8 bits data from input data buffer are read out by slave CPU, the IBF flag will be cleared simultaneously.

## &lt;2&gt; Example for I/O reading cycle from HOST

Reading timing is shown in Figure GF-9.

The basic communication cycles of LPC I/O protocol are 13 cycles. The data of LAD[3:0] will be read by the rising edge of LCLK. Communication will start from  $\overline{\text{LFRAME}}$  falling edge.

- 1<sup>st</sup> cycle: When  $\overline{\text{LFRAME}}$  is "Low", sending "00002 " to LAD[3:0] for communication start detecting.
- 2<sup>nd</sup> cycle: When  $\overline{\text{LFRAME}}$  is "High", the host send "000X2 " on LAD[3:0] to inform the cycle type as I/O read.
- From 3<sup>rd</sup> cycle to 6<sup>th</sup> cycle: These four cycles are detecting for 16 bits slave address.
  - 3<sup>rd</sup> cycle: The slave address which is from host is written to slave address register [15:12] through LAD[3:0]
  - 4<sup>th</sup> cycle: The slave address which is from host is written to slave address register [11:8] through LAD[3:0]
  - 5<sup>th</sup> cycle: The slave address which is from host is written to slave address register [7:4] through LAD[3:0]
  - 6<sup>th</sup> cycle: The slave address which is from host is written to slave address register [3:0] through LAD[3:0]
- 7<sup>th</sup> and 8<sup>th</sup> cycles are used for changing the communication direction from host→slave to slave→host
- 7<sup>th</sup> cycle: Host is output "11112 " to LAD[3:0]
- 8<sup>th</sup> cycle: The LAD[3:0] will be set to Hi-Z by HOST to switch the communication direction.
- 9<sup>th</sup> cycle : The "00002 " (SYNC OK) is output to LAD[3:0] for acknowledge.
- 10<sup>th</sup> and 11<sup>th</sup> cycles are for output 8 bits data from output data buffer or output 8 bits data from status register.
  - 10<sup>th</sup> cycle: Sending output data buffer [3:0] to LAD[3:0] or sending data of status register [3:0] to LAD[3:0]
  - 11<sup>th</sup> cycle: Sending output data buffer [7:4] to LAD[3:0] or sending data of status register [7:4] to LAD[3:0].
- 12<sup>th</sup> cycle: The "11112 " is output to LAD[3:0]. The OBF flag is cleared and OBE interrupt signal is generated.
- 13<sup>th</sup> cycle: The LAD[3:0] will be set to Hi-Z by slave to switch the communication direction. OBF flag will be set when 8 bits data are written to output data buffer by slave CPU.

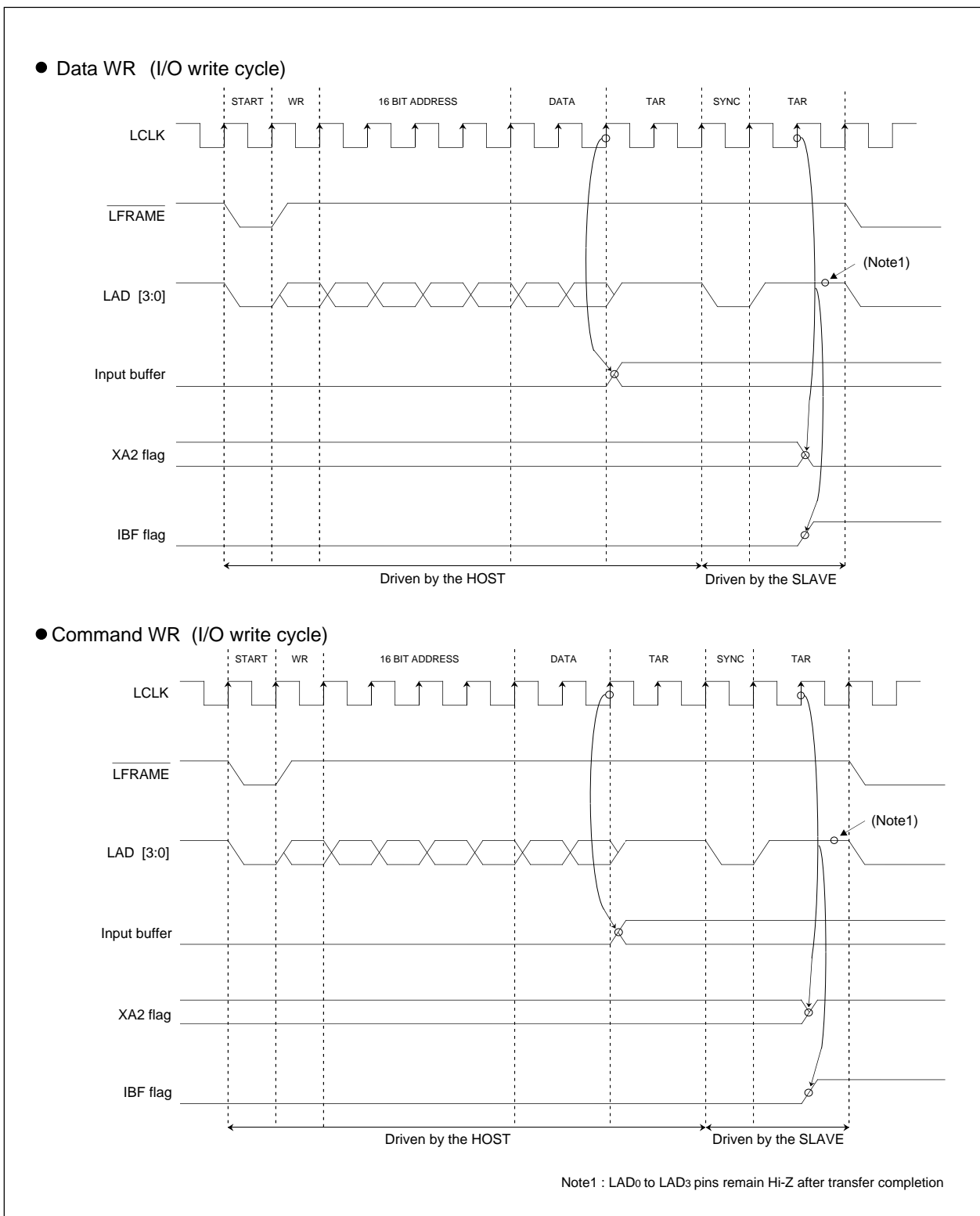

Fig.GF-7 Data and Command write timing figure

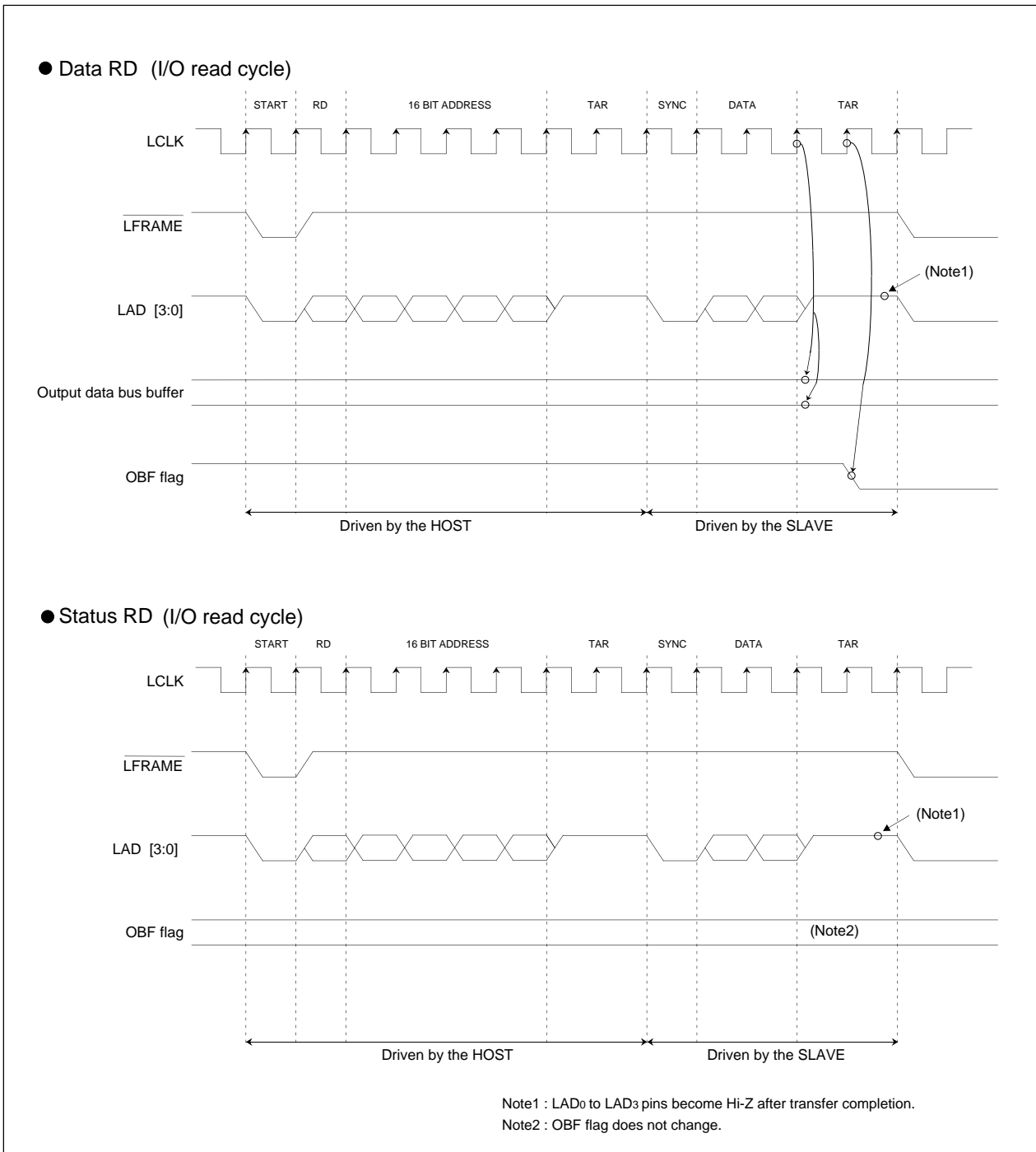

Fig.GF-8 Data and Status read timing figure

Table GF-2 Function explanation of the control input and output pins in LPC bus interface function

Pin name	Name	LPC interface enable bit 02D6 <sub>16</sub> Bit 3	OBFO <sub>0</sub> output enable bit 02C9 <sub>16</sub> Bit 0	OBFO <sub>1</sub> output enable bit 02C9 <sub>16</sub> Bit 1	OBFO <sub>2</sub> output enable bit 02C9 <sub>16</sub> Bit 2	OBFO <sub>3</sub> output enable bit 02C9 <sub>16</sub> Bit 3	OBFO <sub>4</sub> output enable bit 02C9 <sub>16</sub> Bit 4	OBFO <sub>5</sub> output enable bit 02C9 <sub>16</sub> Bit 5	HOSTEN control bit 02C9 <sub>16</sub> Bit 6	Input/ Output	Function
P30/LAD0	LAD0	1	—	—	—	—	—	—	—	I/O	LPC bus used for transmitting and receiving address, command and data between Host CPU and peripheral devices.
P31/LAD1	LAD1	1	—	—	—	—	—	—	—	I/O	
P32/LAD2	LAD2	1	—	—	—	—	—	—	—	I/O	
P33/LAD3	LAD3	1	—	—	—	—	—	—	—	I/O	
P34/LFRAME	LFRAME	1	—	—	—	—	—	—	—	I	It is used for indicating the start of LPC cycle and termination of abnormal communication cycle.
P35/LRESET	LRESET	1	—	—	—	—	—	—	—	I	LPC reset signal. LPC bus interface function is reset.
P36/LCLK	LCLK	1	—	—	—	—	—	—	—	I	LPC synchronous clock signal.
P40/OBF00	OBF00	—	0	1	0	—	—	—	—	O	Status output signal. OBF00 output.
P43/OBF01	OBF01	—	1	0	1	—	—	—	—	O	Status output signal. OBF01 output.
P44/OBF1	OBF1	—	—	—	—	1	—	—	—	O	Status output signal. OBF1 output.
P45/OBF2	OBF2	—	—	—	—	—	1	—	—	O	Status output signal. OBF2 output.
P46/OBF3	OBF3	—	—	—	—	—	—	1	—	O	Status output signal. OBF3 output.

Table GF-3 Conditions of LPC bus interface function induced by  $\overline{\text{LRESET}}$  input

	Pin name / Internal register	$\overline{\text{LRESET}}=\text{"H"}$	$\overline{\text{LRESET}}=\text{"L"}$	Note
Pin	P30/LAD0	LPC bus interface function(function is select)	I/O port	
	P31/LAD1			
	P32/LAD2			
	P33/LAD3			
	P34/LFRAME		I/O port	
	P35/LRESET		LPC bus interface function	
	P36/LCLK			
	P40/OBF00		I/O port	OBF output is enable until $\overline{\text{LRESET}}=\text{"L"}$ . A spike pluse may be output to the port when the port is already set to L output port and OBF signal is output to the port just before $\overline{\text{LRESET}}$ is set to L.
	P43/OBF01			
	P44/OBF1			
	P45/OBF2			
	P46/OBF3			
	P42/GateA20			
Internal register	Input data bus buffer		unstable	
	Output data bus buffer		It can't be written by slave side.	
	U flag 7,6,5,4,2		It can be written and read by slave side.	
	XA2 flag		Initialization to "0"	
	IBF flag		Initialization to "0"	There is possibility to generate IBF interrupt request.
	OBF flag		Initialization to "0"	There is possibility to generate OBE interrupt request.
	LPCADH/L		It can be written and read by slave side.	
	LPCCON		It can be written and read by slave side.	
	GA20 circuit		Initialization	



### GateA20 output function

The GateA20 pin (port P42) can be controlled by LPC interface function channel 0 in hardware. Hardware GateA20 is sharing with P42 pin. Setting "1" to bit 0 of GateA20 control register enables the hardware GateA20 function. The default value of hardware GateA20 is "1".

The GateA20 control register is shown in Fig.GF-9.

When the host CPU writes "D1" command to address 0064<sub>16</sub>, and then writes data to address 0060<sub>16</sub> in succession, the value of bit 1 of the data will be output to GateA20 pin. The timing is shown in Fig.GF-10.

The GateA20 operation sequences are shown in Fig.GF-11, Fig.GF-12. As shown in the figures, there is no change in input buffer full flag (IBF0) and no input buffer full (IBF) interrupt request, but the input data bus buffer and XA2 flag are changed in these sequences.

The value of the GateA20 output pin will be held till the data next to D1 command is written in. P42 becomes I/O port and the the value of GateA20 becomes "0" when  $\overline{\text{LRESET}}$  input is "L". GateA20 will be initialized even if the sequence is executed. However, the GateA20 enable bit will not be changed and GateA20 output pin will be resumed after the  $\overline{\text{LRESET}}$  input becomes "H".

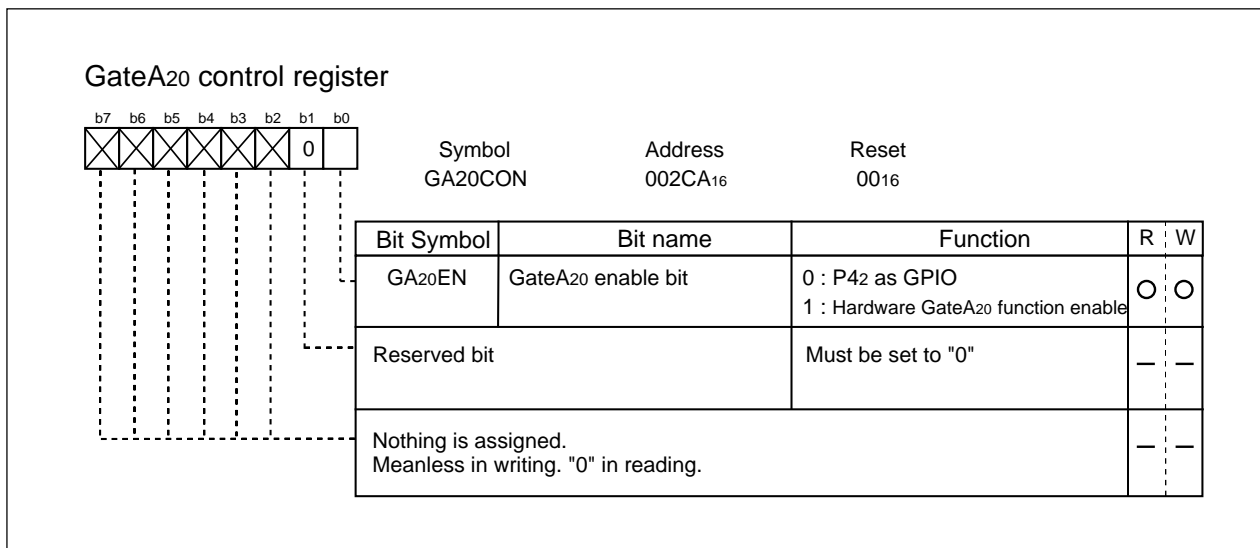

Fig.GF-9 GateA20 control register

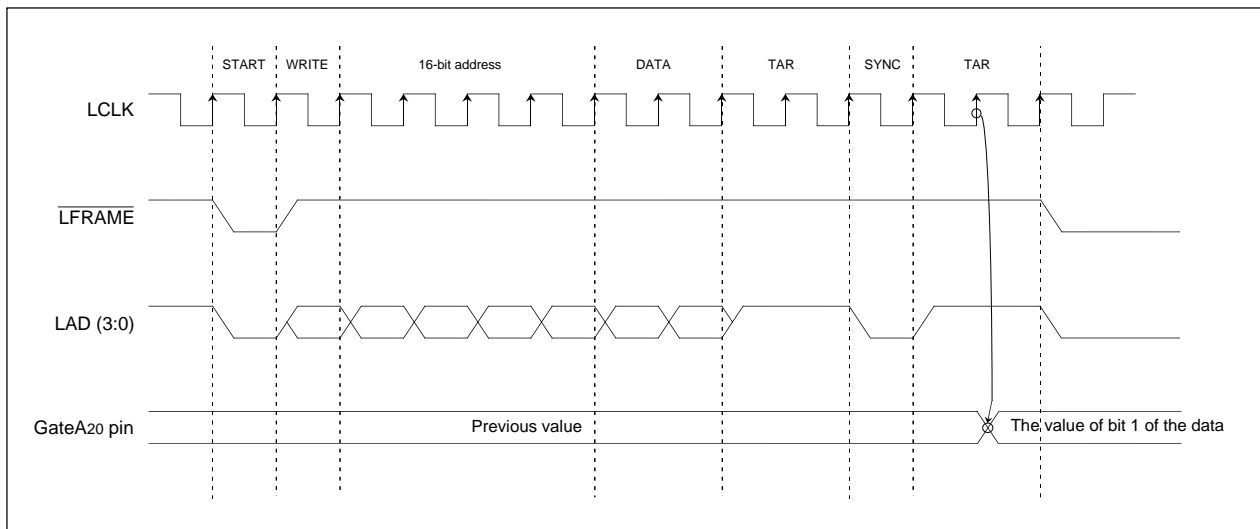
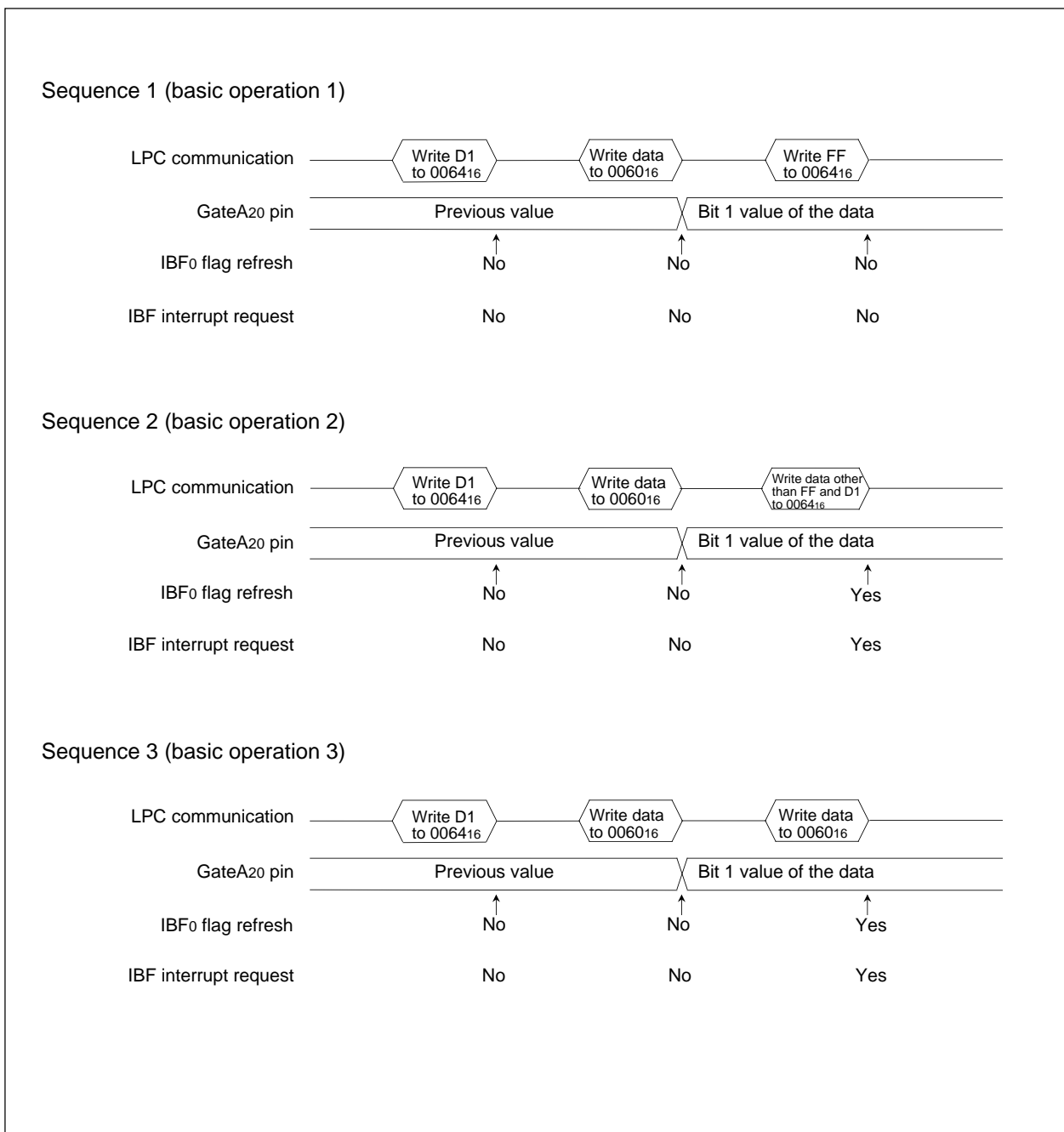
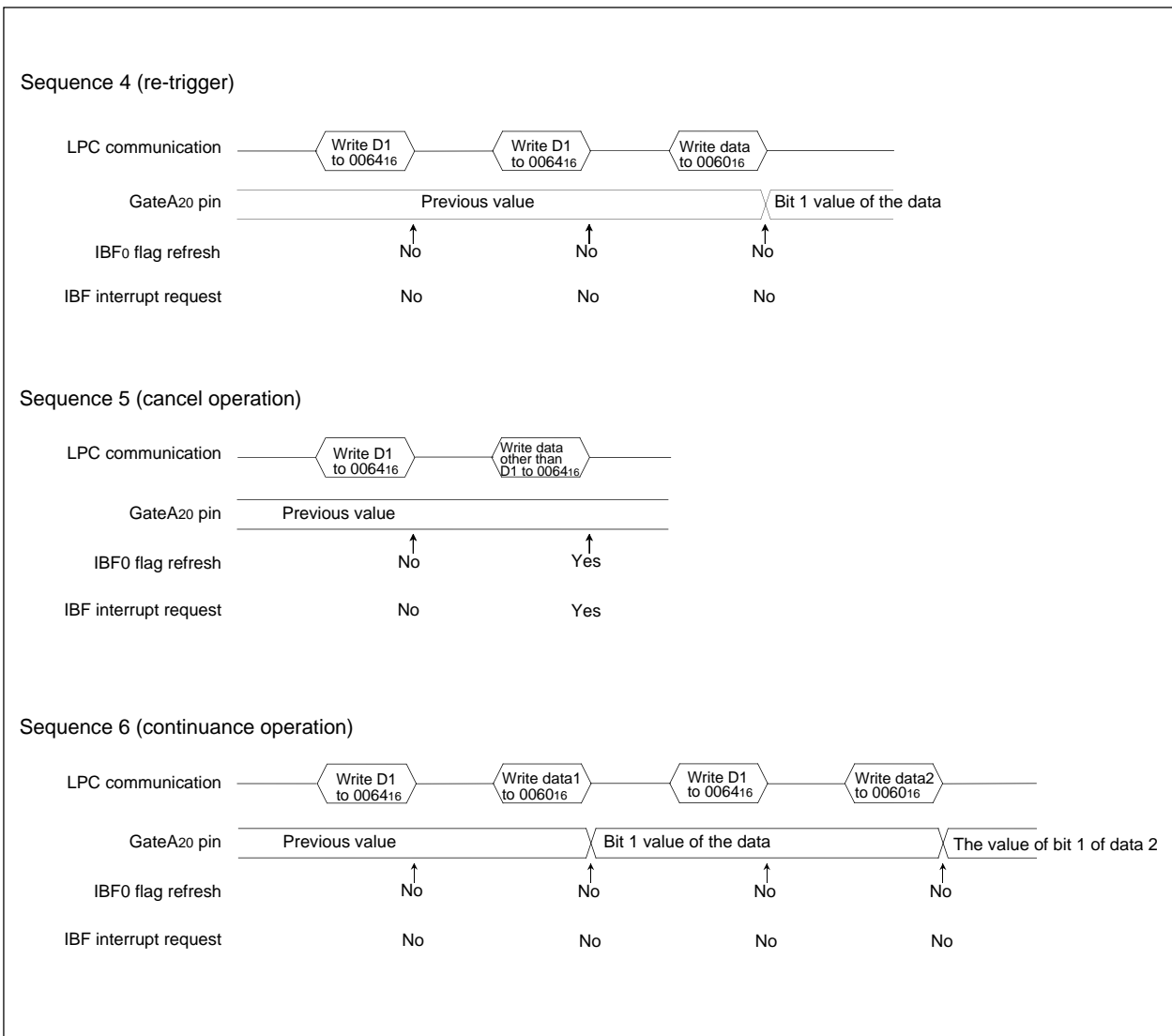

Fig.GF-10 GateA20 output timing



**Fig.GF-11 GateA20 operation sequence (1)**



**Fig.GF-12 GateA20 operation sequence (2)**

## Serial Interrupt Output

The serial interrupt output is the circuit that outputs the interrupt request to the host with serial interrupt data format.

Tab.SI-1 shows the specification of serial interrupt output.

**Table.SI-1 Specifications of serial interrupt output**

Item	Specification
The factors of serial interrupt	<p>The numbers of serial interrupt requests (numbers of channels) that can output simultaneously are 5 factors. Each interrupt factor of each channel is explained as follows.</p> <ul style="list-style-type: none"> <li>• Channel 0               <ol style="list-style-type: none"> <li>① By setting "1" to IRQ<sub>i</sub> request bit (bit 5, 6 i=1,12) of IRQ request register 0, the interrupt request can be generated.</li> <li>② Synchronized with the rising edge of OBF00 and OBF01 that are the host bus interface internal signals, the serial interrupt request can be generated.</li> </ol> </li> <li>• Channel 1-3               <ol style="list-style-type: none"> <li>① By setting "1" to IRQ request bit (bit 5) of IRQ request register 1-3, the interrupt request can be generated.</li> <li>② Synchronized with the rising edge of OBF1-3 that are the host bus interface internal signals, the serial interrupt request can be generated.</li> </ol> </li> <li>• Channel 4               <p>By setting "1" to IRQ request bit (bit 5) of IRQ request register 4, the interrupt request can be generated.</p> </li> </ul>
The number of frame	<ul style="list-style-type: none"> <li>• Channel 0               <ol style="list-style-type: none"> <li>① Setting the IRQ1 request bit (bit 5) of IRQ request register0 to "1" or detecting the rising edge of OBF00, which is the host bus interface internal signal, selects Frame 1.</li> <li>② Setting the IRQ12 request bit (bit 6) of IRQ request register0 to "1" or detecting the rising edge of OBF01, which is the host bus interface internal signal, selects Frame 12.</li> </ol> </li> <li>• Channel 1-4               <p>Selecting the frame select bit (bit 0-4) of IRQ request register1-4 selects Frame 1-15 or extend Frame 0-10.</p> </li> </ul>
Operation clock	The operation synchronized with LCLK (Max. 33MHz). (Note)
Clock restart	Setting the clock restart enable bit (bit 6) of serial interrupt control register0 to "1" requests the clock restart if the clock has stopped or slowed down in serial interrupt output.
Clock stop inhibition	Setting the clock stop inhibition bit (bit 5) of serial interrupt control register0 to "1" requests the inhibition of clock stop if the clock tends to stop or slow down in serial interrupt output.
OBF sync enable	Setting the OBF00, OBF01, OBF1-3 sync enable bit (bit 0-4) of serial interrupt control register0 to "1" enables the OBF synchronization.

Note: To enable LCLK, it is necessary to enable the LPC bus interface function.

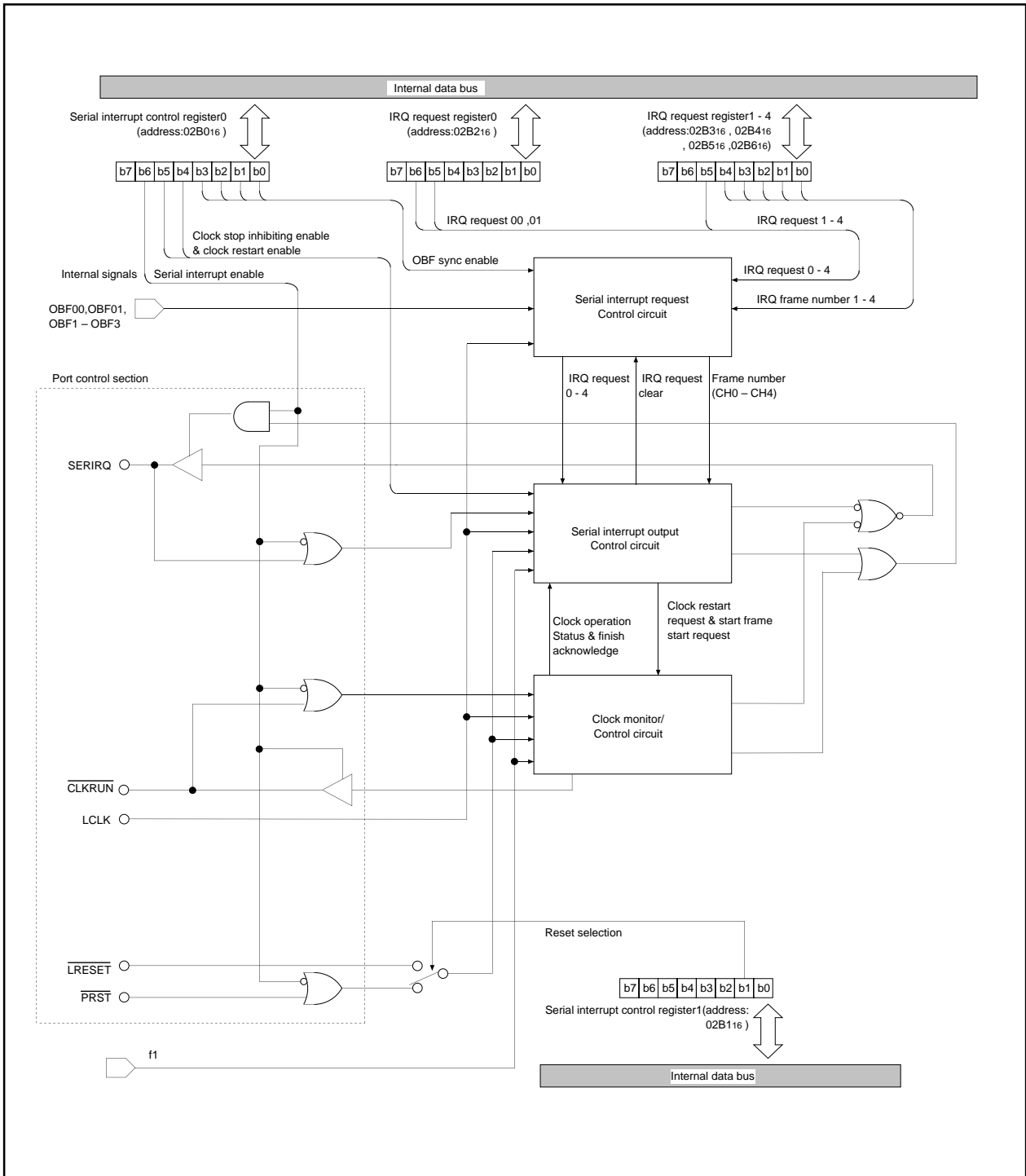

Fig.SI-1 Serial interrupt block chart

**(1) Register explanation**

Fig.SI-2 shows the configuration of IRQ request register0, Fig.SI-3 shows the configuration of IRQ request register1-4, Fig.SI-4, SI-5 show the configurations of serial interrupt control register0,1 respectively.

**● IRQ request register0 IRQR0**

The serial interrupt request of Channel 0 is set by software.

**•IRQ1 request bit IR0**

Setting the bit to “1” generates the serial interrupt request (Frame 1).

By setting the OBF00 sync enable bit (bit 0) of the serial interrupt control register0 to “1”, the value of IR0 is the same as that of OBF00, which is the host bus interface internal signal. When the internal signal OBF00 is "1", the serial interrupt is generated.

IR0 is cleared to "0" by writing "0" in software.

IR0 can not be cleared to "0" by software when the internal signal OBF00 is "1" if OBF00 sync enable bit is set to "1".

**•IRQ12 request bit IR1**

Setting the bit to “1” generates the serial interrupt request (Frame 12).

By setting the OBF01 sync enable bit (bit 1) of the serial interrupt control register0 to “1”, the value of IR1 is the same with that of OBF01, which is the host bus interface internal signal. When the internal signal OBF01 is "1", the serial interrupt is generated.

IR1 is cleared to "0" by writing "0" in software.

IR1 can not be cleared to "0" by software when the internal signal OBF01 is "1" if OBF01 sync enable bit is set to "1".

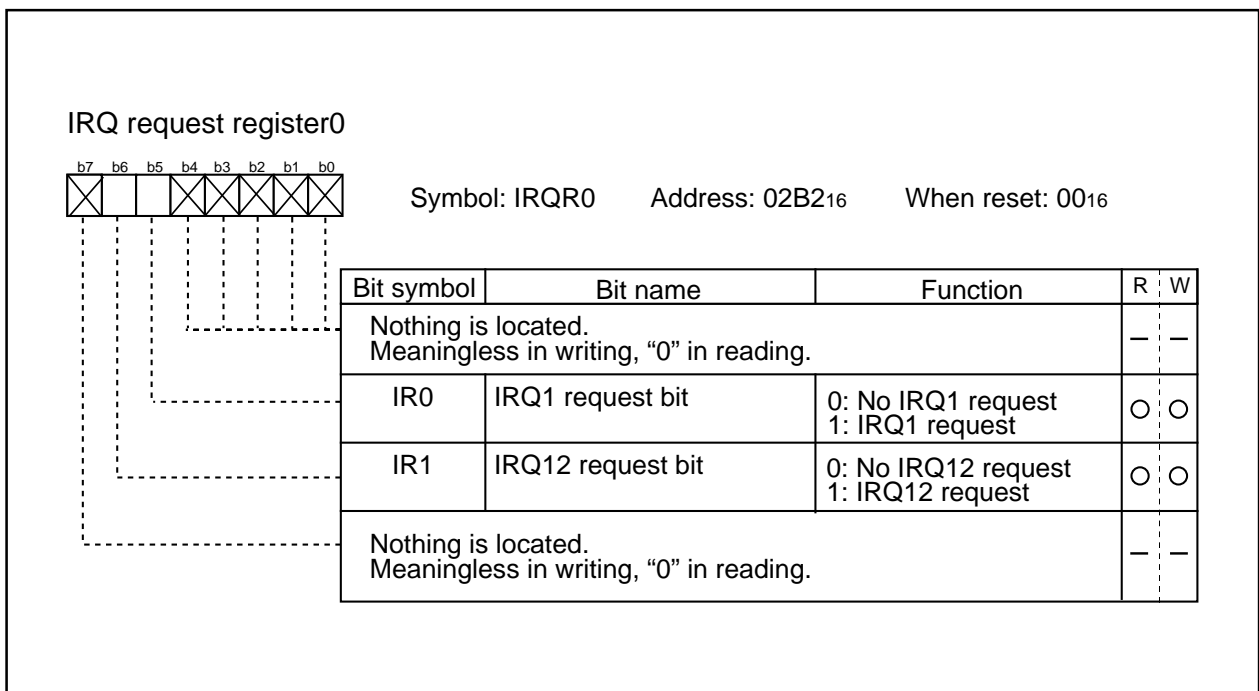

**Fig.SI-2 Configuration of IRQ request register0**

● **IRQ request register i IRQRi (i=1-4)**

The serial interrupt request of Channel 1-4 is set by software, or asserting frame is selected.

● **IRQ request bit IR**

Setting the bit to "1" generates the serial interrupt request.

By setting the OBFj sync enable bit (bit2-4, j=1-3) of the serial interrupt control register0 to "1", the value of IR is the same as that of OBFj, which is the host bus interface internal signal. When the internal signal OBFj is "1", the serial interrupt is generated.

IR is cleared to "0" by writing "0" in software.

IR can not be cleared to "0" by software when the internal signal OBFj is "1" if OBFj sync enable bit is set to "1".

● **IRQ select bit IS0-4**

The asserting frame is selected.

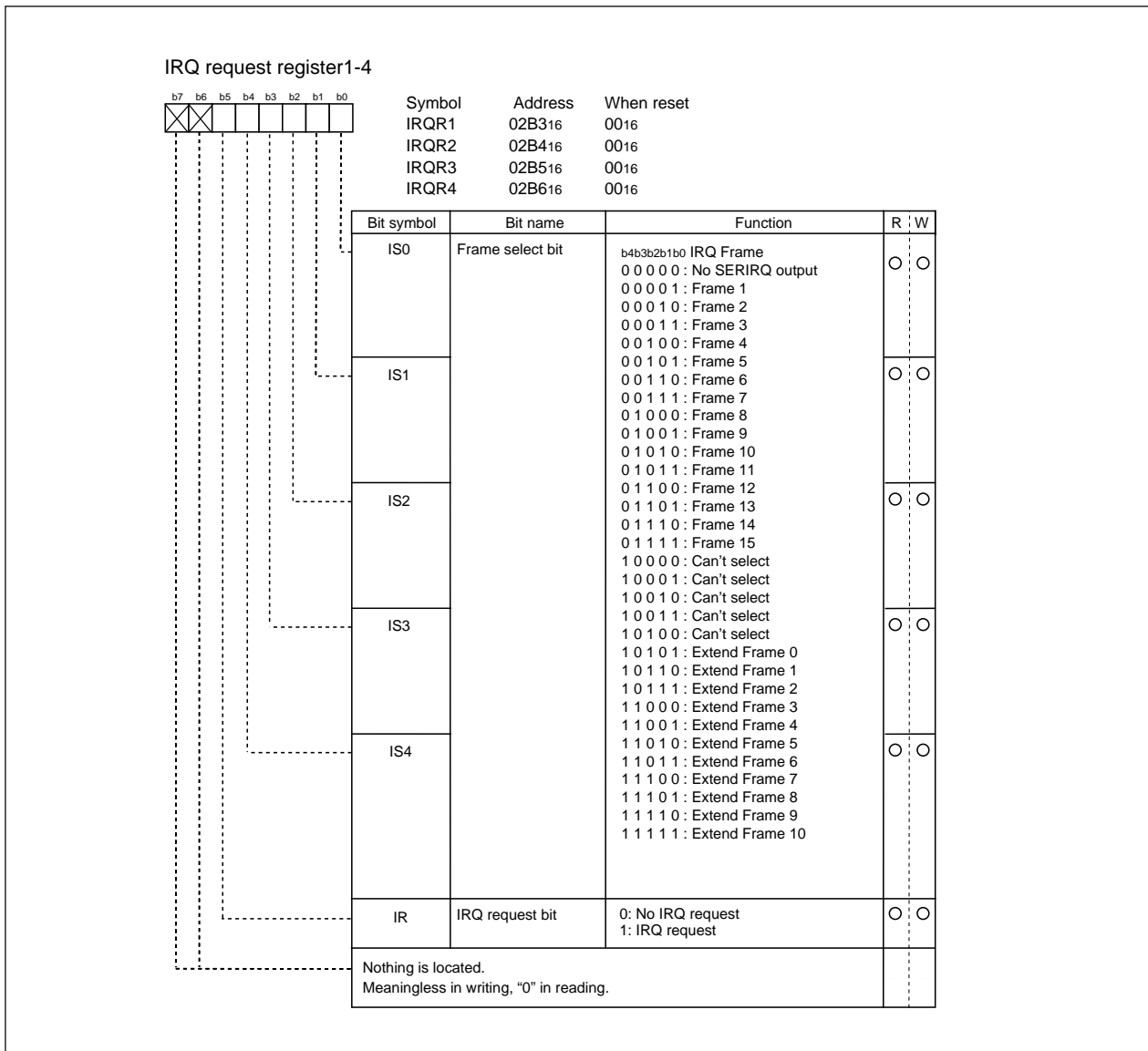

Fig.SI-3 Configuration of IRQ request register1-4

● **Serial interrupt control register0 SERCON0**

The operation condition of serial interrupt is set.

● **OBFi sync enable bit SENi (i=00,01,1-3)**

By setting the bit to “1”, the rising edge of OBFi output to host bus interface generates the serial interrupt request synchronously.

● **Clock stop inhibition bit SUPEN**

Setting the bit to “1” will request the inhibition of clock if the clock tends to stop or slow down in serial interrupt request.

● **Clock restart enable bit RUNEN**

Setting the bit to “1” requests the clock restart during the clock stop or clock slow down in serial interrupt request.

● **Serial interrupt enable bit IRQEN**

0: SERIRQ, PRST, CLKRUN are I/O ports.

1: SERIRQ, PRST, CLKRUN are serial interrupt function ports.

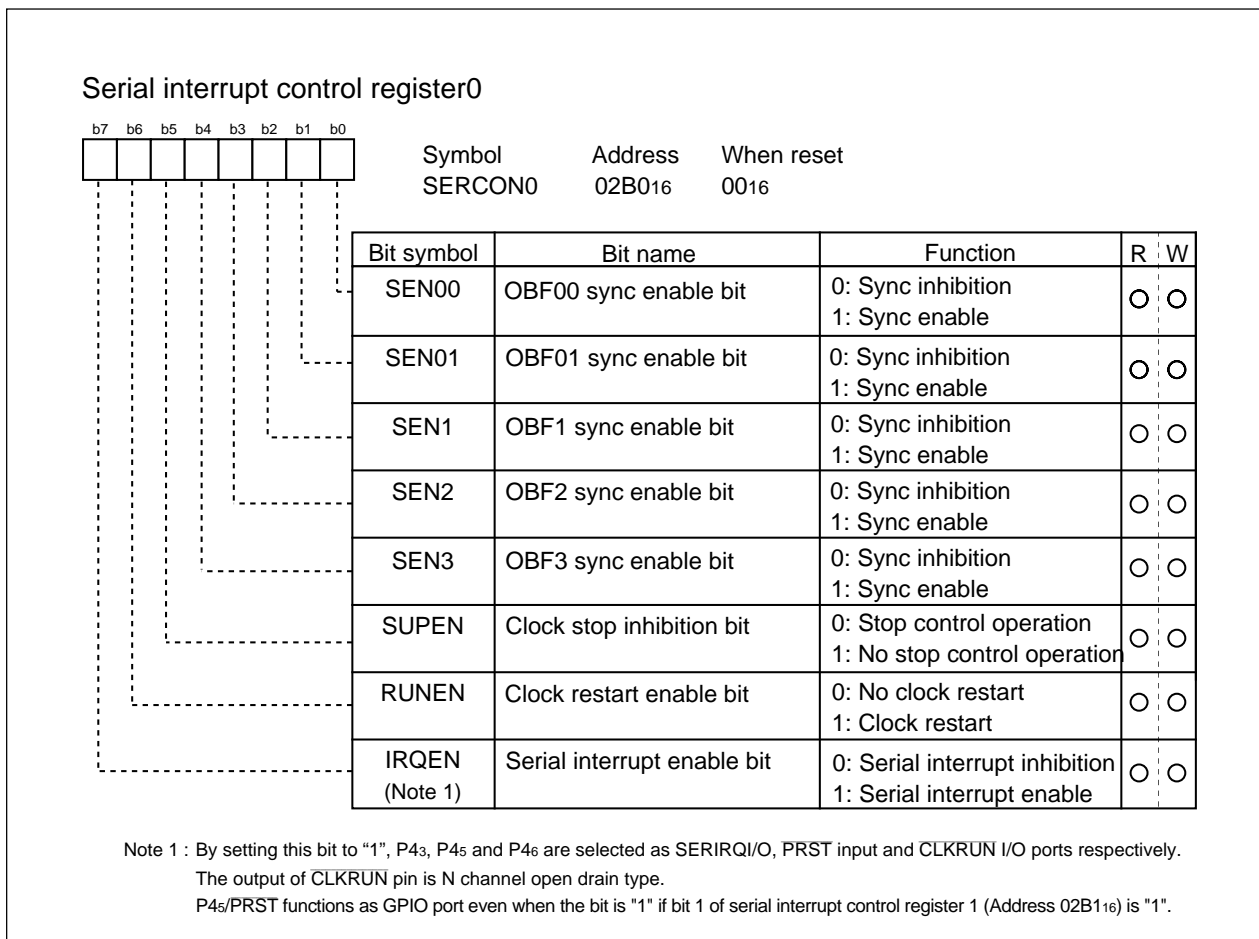

Fig.SI-4 Configuration of serial interrupt control register0



● **Serial interrupt control register1 SERCON1**

The register is for setting the pins of serial interrupt.

● **Reset selection bit RSEL**

0: The input of  $\overline{PRST}$  is the reset signal.

1: The input of  $\overline{LRESET}$  is the reset signal. (Note1)

Note 1: The  $\overline{PRST}$  pin becomes I/O port if setting the bit to “1”.

● **OBFO merge function**

By setting the bit to “1”, the signal, which is logically OR by OBF00 and OBF01 signals from LPC bus interface, will output to IRQ1 and IRQ12 of serial interrupt circuit.

Fig.SI-6 shows the selection circuit controlled by the bit.

With the function, the IRQ1 and IRQ12 request bits can be cleared simultaneously by H/W at the read of output data buffer from system if both IRQ1 and IRQ12 request bits are set in the case that IRQ1 request bit (or IRQ12 request bit) is set after that of IRQ12 (or IRQ1) because of the overwrite to the output data buffer.

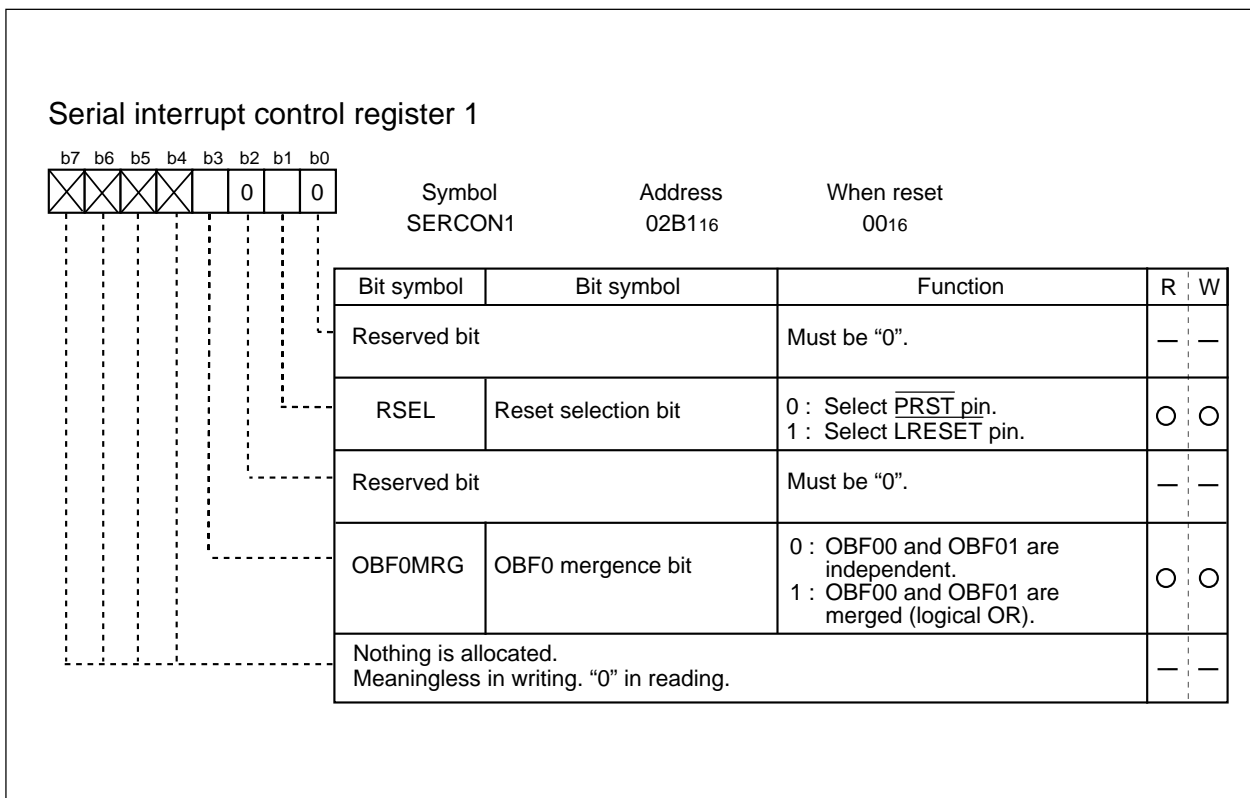

Fig.SI-5 Configuration of serial interrupt control register1

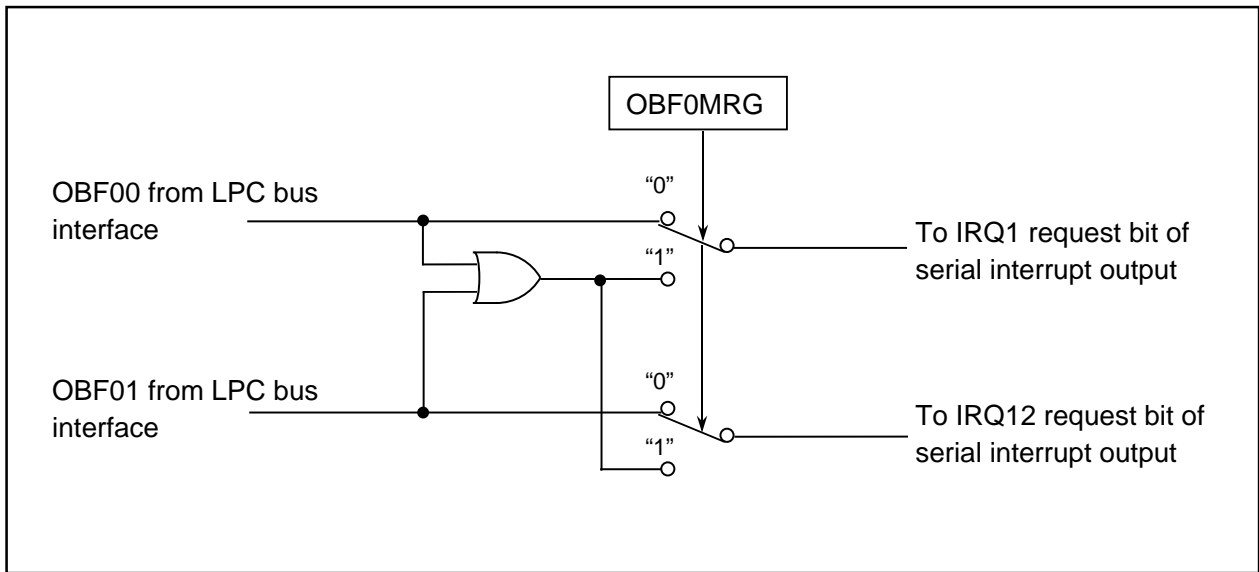

Fig.SI-6 The selection circuit controlled by OBF0MRG

● **Serial interrupt control register2 SERCON2**

The polarity of serial interrupt output can be selected by bit 0 to bit 5 of serial interrupt control register 2.

When the bit is set to “0”:

    If there is a request,   Hiz-Hiz-Hiz

    If there is no request, L-H-Hiz

When the bit is set to “1”:

    If there is a request,   L-H-Hiz

    If there is no request, Hiz-Hiz-Hiz

Only the default value of bit 4 (serial interrupt polarity bit 3) of serial interrupt control register 2 after reset is “1”.

Fig.SI-7 shows the configuration of serial interrupt control register 2.

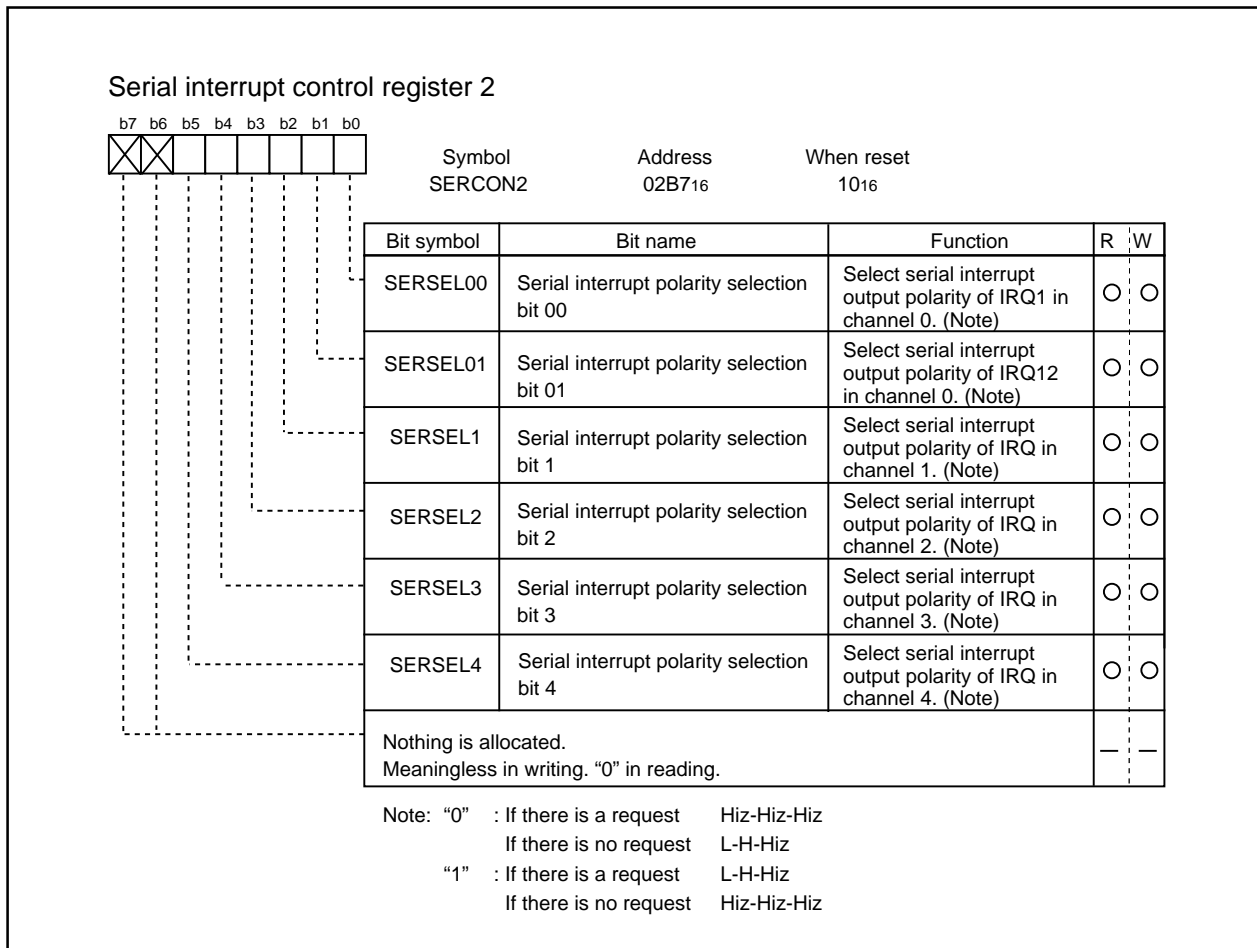

Fig.SI-7 The configuration of serial interrupt control register 2

## (2) The operation of serial interrupt

A cycle operation of serial interrupt starts with start frame and finishes with stop frame. There are 2 kinds of operation mode: continuous mode and quiet mode. The next operation mode is judged by monitoring the length of stop frame sent from host side.

### ● The timing of serial interrupt cycle

Fig.SI-8 shows an example of basic timing of serial interrupt cycle.

#### ① Start frame

The start frame will be detected if the SERIRQ remains "L" in 4-8 clock cycles.

#### ② IRQ data frame

Each IRQ data frame is 3 clock cycles.

- Channel 0-2,4: If the IRQ request bit is "0", then the SERIRQ is driven to "L" during the 1<sup>st</sup> clock cycle of the corresponding data frame, to "H" during the 2<sup>nd</sup> clock cycle, to high impedance during the 3<sup>rd</sup> clock cycle. If the IRQ request bit is "1", then the SERIRQ is high impedance during all of the 3 clock cycles.

- Channel 3: If the IRQ request bit is "0", then the SERIRQ is high impedance during all of the 3 clock cycles. If the IRQ request bit is "1", then the SERIRQ is driven to "L" during the 1<sup>st</sup> clock cycle of the corresponding data frame, to "H" during the 2<sup>nd</sup> clock cycle, to high impedance during the 3<sup>rd</sup> clock cycle.

#### ③ Stop frame

The stop frame will be detected if the SERIRQ remains "L" in 2 or 3 clock cycles. The next operation mode is quiet mode if the length of "L" is 2 clock cycles, the continuous mode mode if the length is 3 clock cycles.

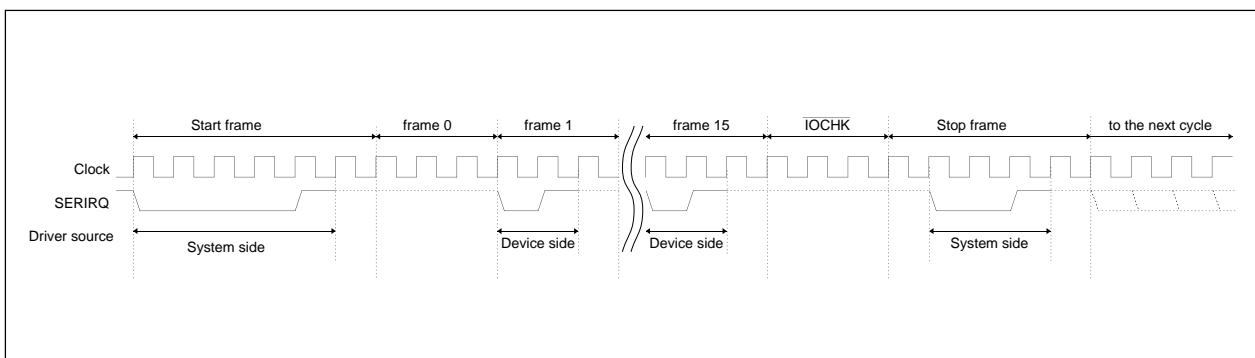

Fig.SI-8 Basic timing of serial interrupt cycle

## ● Operation mode

Fig.SI-9 shows an example of timing of continuous mode, Fig.SI-10 shows that of quiet mode.

### ① Continuous mode

After reset, at the rising edge of  $\overline{\text{PRST}}$  (or  $\overline{\text{LRESET}}$ ) or the length of the last stop frame of serial interrupt cycle being 3 clock cycles, it will be the continuous mode.

After receiving the start frame (Note 1), the Frame 1, Frame 12 or frames selected in each channel will be asserted.

Note 1: If the length of "L" is less than 4 clock cycles or more than 9 clock cycles, the start frame will not be detected and the next start (the falling edge of SERIRQ) is waited.

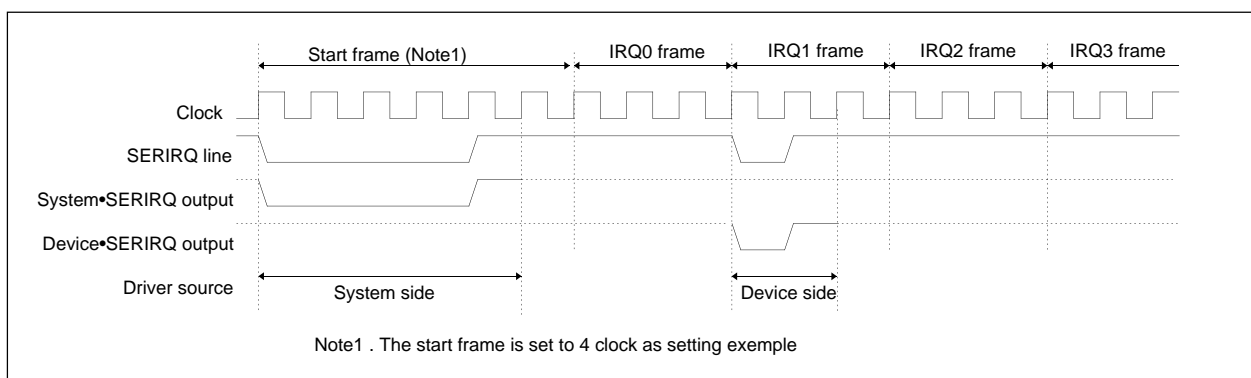

Fig.SI-9 Timing diagram of continuous mode

### ② Quiet mode

At clock stop or clock slow down, or the length of the last stop frame of serial interrupt cycle being 2 clock cycles, it will be the quiet mode.

In this mode the SERIRQ is driven to "L" in the 1<sup>st</sup> clock cycle by device and after the receiving of the rest start frame (Note 1) from host, the IRQ1 Frame , IRQ12 Frame or frames selected in each channel will be asserted.

Note 1: If the sum of length of "L" that is driven by the device in the 1<sup>st</sup> clock cycle and by the host in the rest clock cycles is within 4-8 clock cycles, the start frame will be detected.

If the sum of length of "L" is less than 4 clock cycles or more than 9 clock cycles, the start frame will not be detected and the next start (the falling edge of SERIRQ) is waited.

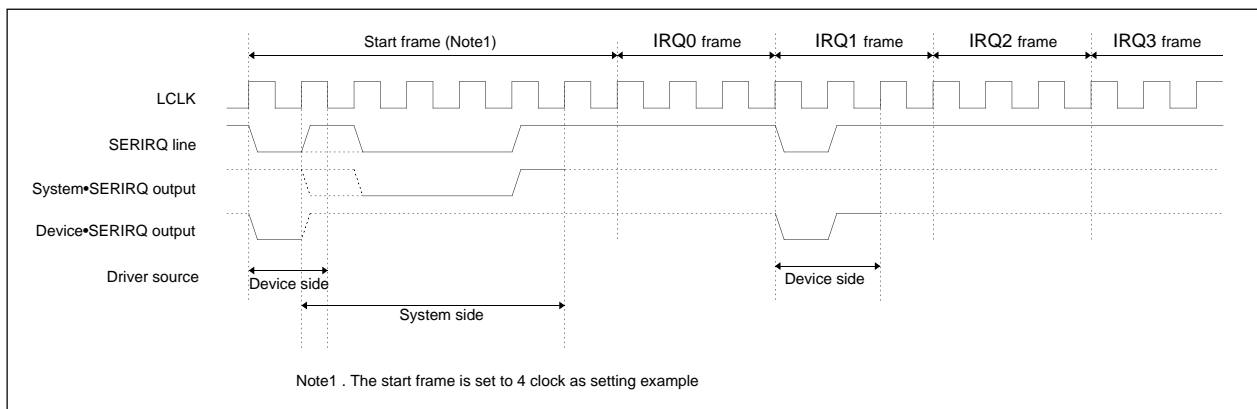

Fig.SI-10 Timing diagram of quiet mode

### (3) Clock restart/ stop inhibition request

Asserting the  $\overline{\text{CLKRUN}}$  signal can request to restart or maintain the clock which stops or slows down or request the host to tend to stop or slow down.

Fig.SI-11 shows an example of timing of clock restart request, Fig.SI-12 shows an example of timing of clock stop inhibition request.

#### ① Clock restart operation

Setting the clock restart bit of serial interrupt control register0 to “1” will request the clock restart if the clock has slowed down or stopped at serial interrupt request.

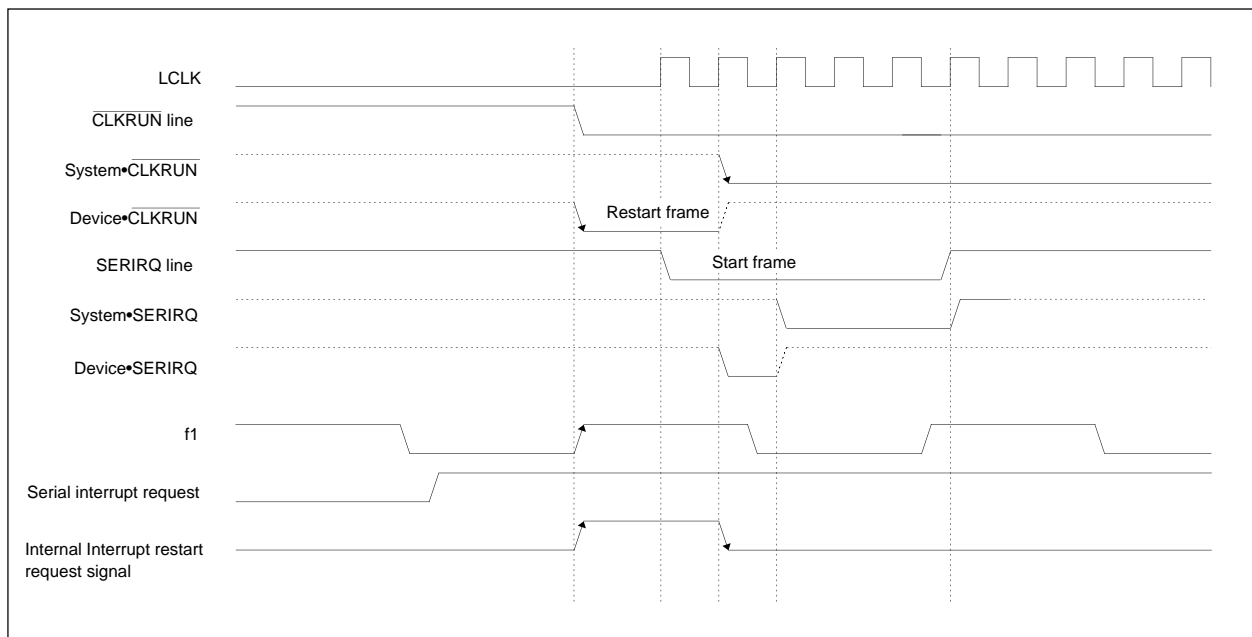

**Fig.SI-11 Timing diagram of clock restart request**

#### ② Clock stop inhibition request

Setting the clock stop inhibition bit of serial interrupt control register0 to “1” will request the inhibition of clock stop if the clock tends to stop or slow down during all the period of serial interrupt output.

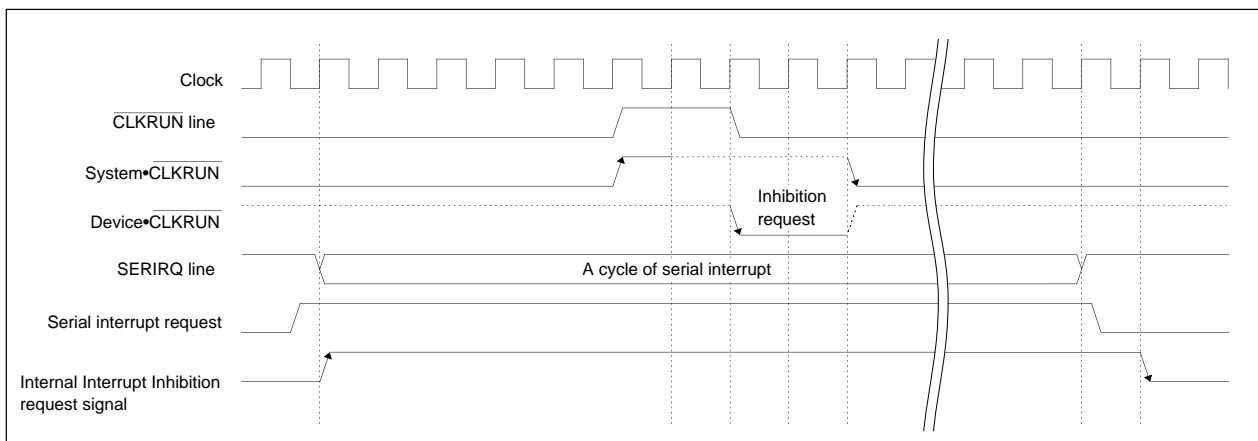

**Fig.SI-12 Example of timing of clock stop inhibition request**

## MULTI-MASTER I<sup>2</sup>C-BUS INTERFACE

The multi-master I<sup>2</sup>C-BUS interface is a serial communication circuit based on Philips I<sup>2</sup>C-BUS data transfer format. 2 independent channels, with both arbitration lost detection and a synchronous functions, are built in for the multi-master serial communication. Fig.GC-1 shows a block diagram of the multi-master I<sup>2</sup>C-BUS interface and Table.GC-1 lists the multi-master I<sup>2</sup>C-BUS interface functions. The multi-master I<sup>2</sup>C-BUS interface consists of the I<sup>2</sup>C address register, the I<sup>2</sup>C data shift register, the I<sup>2</sup>C clock control register, the I<sup>2</sup>C control register 1, I<sup>2</sup>C control register 2, the I<sup>2</sup>C status register, the I<sup>2</sup>C start/stop condition control register and other control circuits.

**Table.GC-1 Multi-master I<sup>2</sup>C-BUS interface functions**

Item	Function
Format	Based on Philips I <sup>2</sup> C-BUS standard: 10-bit addressing format 7-bit addressing format High-speed clock mode Standard clock mode
Communication mode	Based on Philips I <sup>2</sup> C-BUS standard: Master transmission Master reception Slave transmission Slave reception
SCL clock frequency	16.1kHz to 400kHz (at V <sub>IIC</sub> = 4MHz)

\*V<sub>IIC</sub>=I<sup>2</sup>C system clock

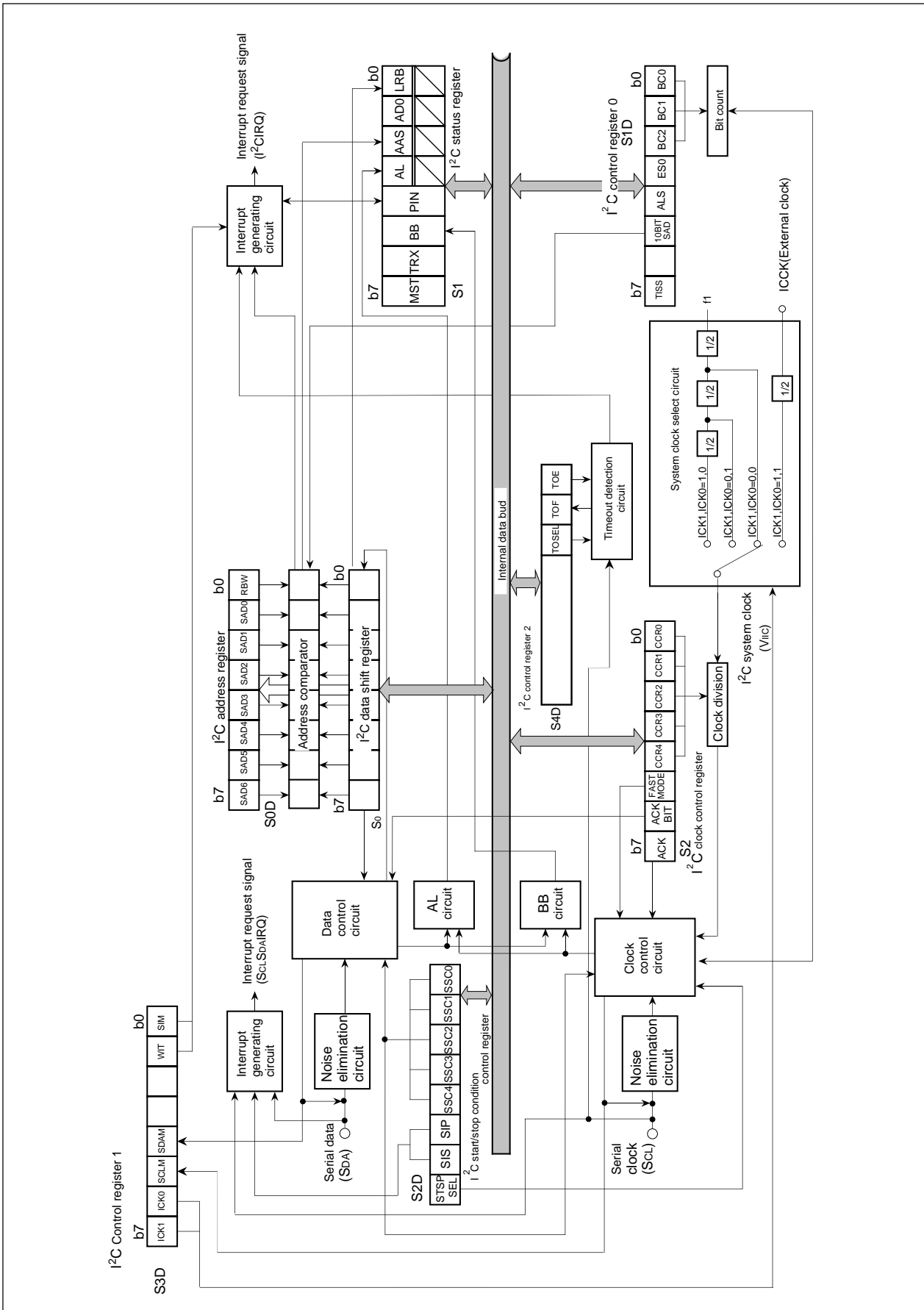

Fig.GC-1 Block diagram of multi-master I<sup>2</sup>C-BUS interface



### I<sup>2</sup>C Data Shift Register

The I<sup>2</sup>C data shift register (address 0320<sub>16</sub>,0330<sub>16</sub>) is an 8-bit shift register to store receiving data and write transmission data. When transmit data is written into this register, it is transferred to the outside from bit 7 in synchronization with the SCL clock, and each time one-bit data is output, the data of this register are shifted by one bit to the left. When data is received, it is input to this register from bit 0 in synchronization with the SCL clock, and each time one-bit data is input, the data of this register are shifted by one bit to the left. The timing of storing received data to this register is shown in figure GC-3. The I<sup>2</sup>C data shift register is in a write enable status only when the I<sup>2</sup>C-BUS interface enable bit (ES0 bit : bit 3 of address 0323<sub>16</sub>,0333<sub>16</sub>) of the I<sup>2</sup>C control register 0 is "1". The bit counter is reset by a write instruction to the I<sup>2</sup>C data shift register. When both the ES0 bit and the MST bit of the I<sup>2</sup>C status register (address 0328<sub>16</sub>,0338<sub>16</sub>) are "1", the SCL is output by a write instruction to the I<sup>2</sup>C data shift register. Reading data from the I<sup>2</sup>C data shift register is always enabled regardless of the value of ES0 bit.

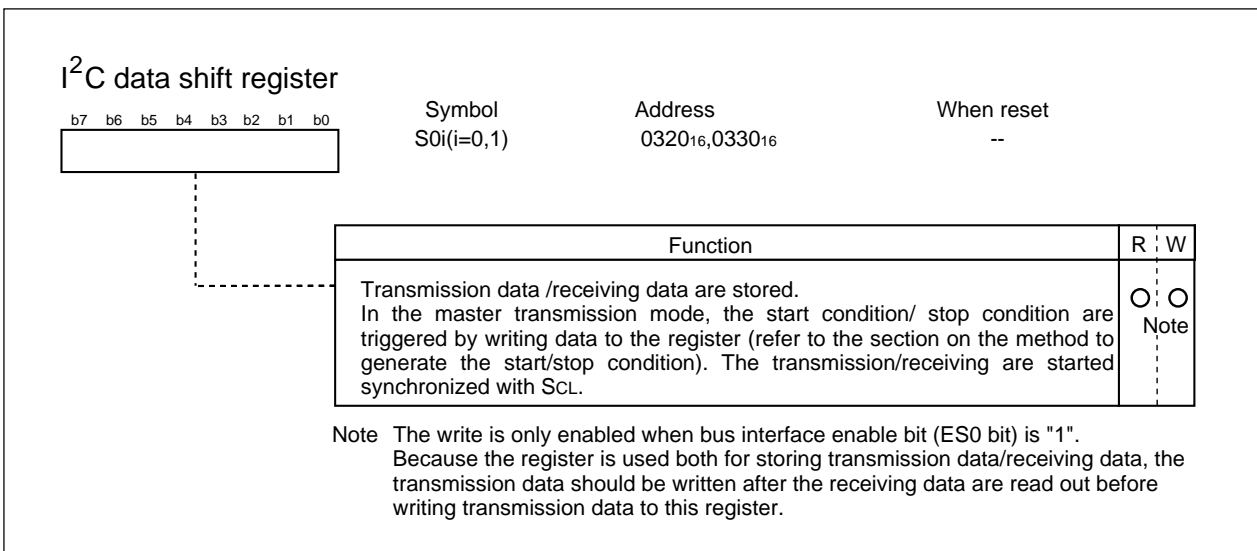

Fig.GC-2 I<sup>2</sup>C data shift register

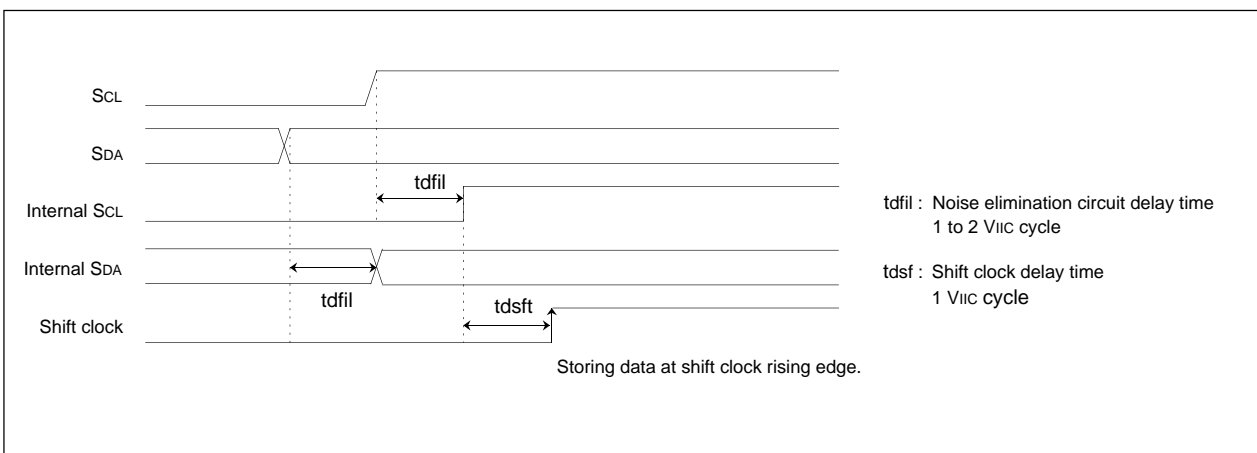

Fig.GC-3 The timing of receiving data stored to I<sup>2</sup>C data shift register

### I<sup>2</sup>C Address Register

The I<sup>2</sup>C address register (address 0322<sub>16</sub>,0332<sub>16</sub>) consists of a 7-bit slave address and a read/write bit. In the addressing mode, the slave address written in this register is compared with the address data to be received immediately after the START condition is detected.

**•Bit 0: Read/write bit (RBW)**

This is not used in the 7-bit addressing mode. In the 10-bit addressing mode, the first byte address data to be received are compared with the contents (SAD6 to SAD0 + RBW) of the I<sup>2</sup>C address register. The RBW bit is cleared to "0" automatically when the stop condition is detected.

**•Bits 1 to 7: Slave address (SAD0–SAD6)**

These bits store slave addresses. Regardless of the 7-bit addressing mode or the 10-bit addressing mode, the address data transmitted from the master is compared with the contents of these bits.

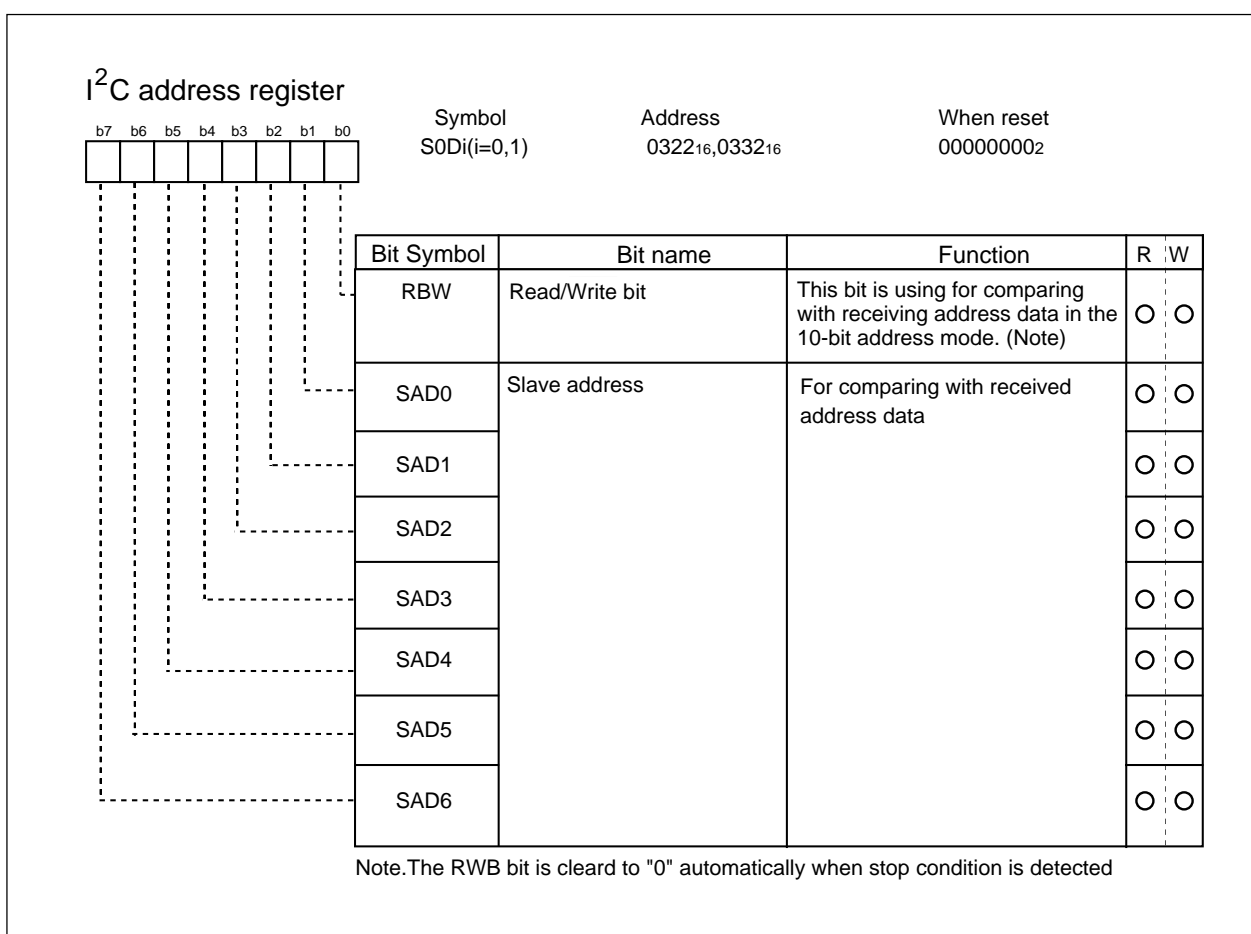

**Fig.GC-4 I<sup>2</sup>C address register**

## I<sup>2</sup>C Clock Control Register

The I<sup>2</sup>C clock control register 0,1 (address 0324<sub>16</sub>,0334<sub>16</sub>) is used to set ACK control, SCL mode and SCL frequency.

### •Bits 0 to 4: SCL frequency control bits (CCR0–CCR4)

These bits control the SCL frequency. Refer to Table GC-2.

### •Bit 5: SCL mode specification bit (FAST MODE)

This bit specifies the SCL mode. When this bit is set to “0”, the standard clock mode is selected. When the bit is set to “1”, the high-speed clock mode is selected. When connecting to the bus with the high-speed mode I<sup>2</sup>C-BUS standard (maximum 400 kbits/s), set 4 MHz or more to I<sup>2</sup>C system clock(V<sub>IIC</sub>).

### •Bit 6: ACK bit (ACK BIT)

This bit sets the SDA status when an ACK clock is generated. When this bit is set to “0”, the ACK return mode is selected and SDA goes to “L” at the occurrence of an ACK clock. When the bit is set to “1”, the ACK nonreturn mode is selected. The SDA is held in the “H” status at the occurrence of an ACK clock. However, when the slave address agrees with the address data in the reception of address data at ACK BIT = “0”, the SDA is automatically made “L” (ACK is returned). If there is a disagreement between the slave address and the address data, the SDA is automatically made “H” (ACK is not returned).

\*ACK clock: Clock for acknowledgment

### •Bit 7: ACK clock bit (ACK)

This bit specifies the mode of acknowledgment which responds to the data transferring. When this bit is set to “0”, the no ACK clock mode is selected. In this case, no ACK clock occurs after data transmission. When the bit is set to “1”, the ACK clock mode is selected and the master generates an ACK clock at the completion of each 1-byte data transfer. The device for transmitting address data and control data releases the SDA at the occurrence of an ACK clock (makes SDA “H”) and receives the ACK bit generated by the data receiving device.

**Note:** Except for ACK bit (ACKBIT), do not write data into the I<sup>2</sup>C clock control register during transfer.

If data is written during transfer, the I<sup>2</sup>C clock generator is reset, so that data cannot be transferred normally.

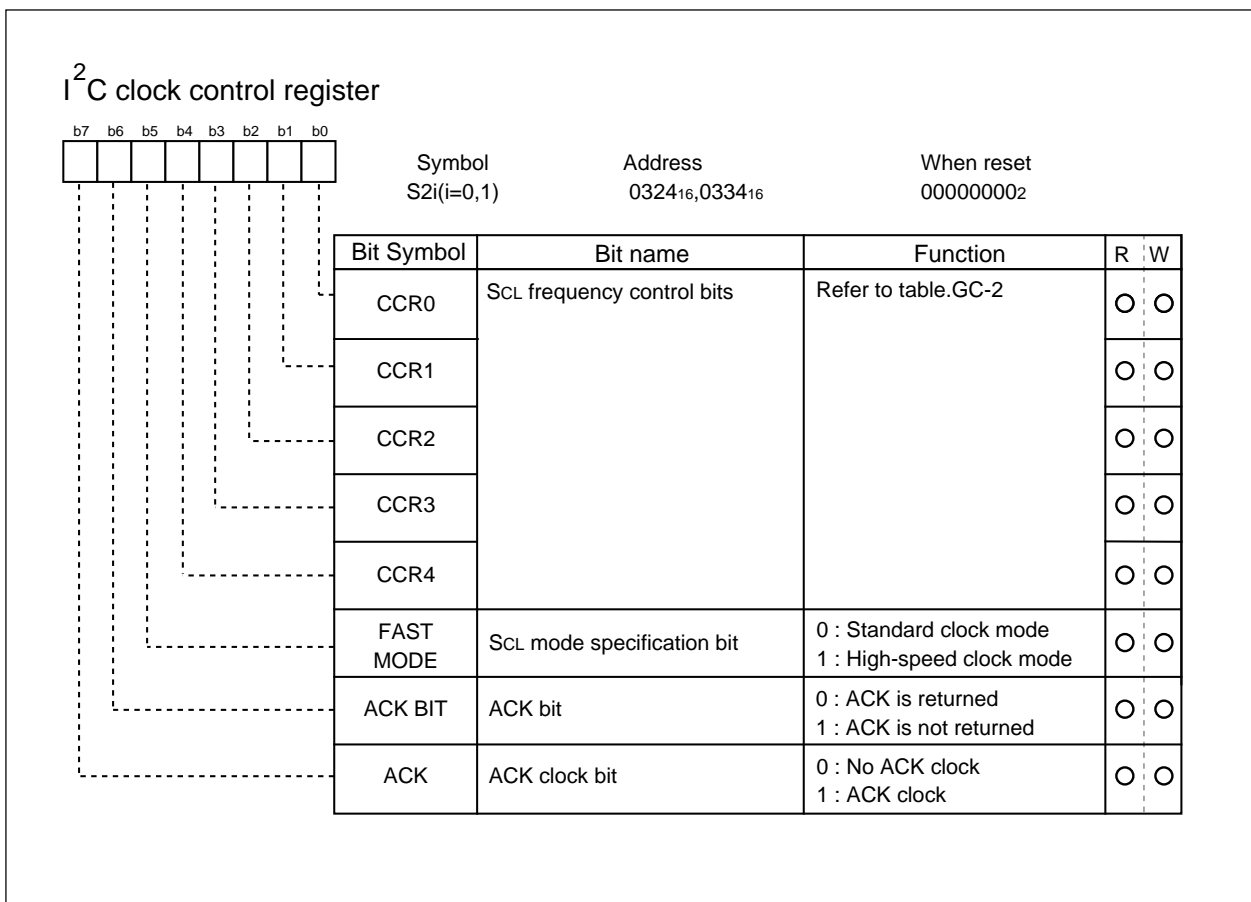

Fig.GC-5 I<sup>2</sup>C clock register

**Table.GC-2 Set values of I<sup>2</sup>C clock control register and SCL frequency**

Setting value of CCR4 to CCR0					SCL frequency (at V <sub>IIC</sub> =4MHz, unit : kHz) (Note1)	
CCR4	CCR3	CCR2	CCR1	CCR0	Standard clock mode	High-speed clock mode
0	0	0	0	0	Setting disabled	Setting disabled
0	0	0	0	1	Setting disabled	Setting disabled
0	0	0	1	0	Setting disabled	Setting disabled
0	0	0	1	1	- (Note2)	333
0	0	1	0	0	- (Note2)	250
0	0	1	0	1	100	400 (Note3)
0	0	1	1	0	83.3	166
↓	↓	↓	↓	↓	500 / CCR value (Note3)	1000 / CCR value (Note3)
1	1	1	0	1	17.2	34.5
1	1	1	1	0	16.6	33.3
1	1	1	1	1	16.1	32.3

**Notes1:** Duty of SCL clock output is 50 %. The duty becomes 35 to 45 % only when the high-speed clock mode is selected and CCR value = 5 (400 kHz, at V<sub>IIC</sub> = 4 MHz). "H" duration of the clock fluctuates from -4 to +2 machine cycles in the standard clock mode, and fluctuates from -2 to +2 machine cycles in the high-speed clock mode. In the case of negative fluctuation, the frequency does not increase because "L" duration is extended instead of "H" duration reduction. These are value when SCL clock synchronization by the synchronous function is not performed. CCR value is the decimal notation value of the SCL frequency control bits CCR4 to CCR0.

**2:** Each value of SCL frequency exceeds the limit at V<sub>IIC</sub> = 4 MHz or more. When using these setting value, use V<sub>IIC</sub> = 4 MHz or less. Refer to I<sup>2</sup>C system clock selection bits (bit 6,7 of I<sup>2</sup>C control register 1) on V<sub>IIC</sub>.

**3:** The data formula of SCL frequency is described below:

V<sub>IIC</sub>/(8 X CCR value) Standard clock mode

V<sub>IIC</sub>/(4 X CCR value) High-speed clock mode (CCR value ≠ 5)

V<sub>IIC</sub>/(2 X CCR value) High-speed clock mode (CCR value = 5)

Do not set 0 to 2 as CCR value regardless of V<sub>IIC</sub> frequency.

Set 100 kHz (max.) in the standard clock mode and 400 kHz (max.) in the high-speed clock mode to the SCL frequency by setting the SCL frequency control bits CCR4 to CCR0.

## I<sup>2</sup>C Control Register 0

The I<sup>2</sup>C control register 0 (address 0323<sub>16</sub>,0333<sub>16</sub>) of channel 0, 1 controls data communication format.

### •Bits 0 to 2: Bit counter (BC0–BC2)

These bits decide the number of bits for the next 1-byte data to be transmitted. The I<sup>2</sup>C interrupt request signal occurs immediately after the number of count specified with these bits (ACK clock is added to the number of count when ACK clock is selected by ACK bit (bit 7 of address 0324<sub>16</sub>,0334<sub>16</sub>)) have been transferred, and BC0 to BC2 are returned to “0002”.

Also when a START condition is detected, these bits become “0002” and the address data is always transmitted and received in 8 bits.

### •Bit 3: I<sup>2</sup>C interface enable bit (ES0)

This bit enables to use the multi-master I<sup>2</sup>C-BUS interface. When this bit is set to “0”, the interface is disabled and the SDA and the SCL become high-impedance. When the bit is set to “1”, the interface is enabled.

When ES0 = “0”, the following is performed.

- 1)Set MST = “0”, TRX = “0”, PIN = “1”, BB = “0”, AL = “0”, AAS = “0”, and AD0 = “0”, of I<sup>2</sup>C status register (Address : 0328<sub>16</sub>, 0338<sub>16</sub>)
- 2)Writing data to I<sup>2</sup>C data shift register (Address : 0320<sub>16</sub>, 0330<sub>16</sub>) is inhibited.
- 3)The TOF bit of I<sup>2</sup>C control register (Address : 0327<sub>16</sub>,0337<sub>16</sub>) is cleared to “0”
- 4)I<sup>2</sup>C system clock (V<sub>IIC</sub>) is stopped and the interval counter, flags are initialized.

### •Bit 4: Data format selection bit (ALS)

This bit decides if the recognition of slave address should be processed. When this bit is set to “0”, the addressing format is selected, so that address data will be recognized. The transfer will be processed only when a comparison is matched between the slave address and the address data or a general call is received (refer to the item of bit 1 of I<sup>2</sup>C status register: general call detection flag). When this bit is set to “1”, the free data format is selected, so that slave address will not be recognized.

### •Bit 5: Addressing format selection bit (DBIT SAD)

This bit selects a slave address specification format. When this bit is set to “0”, the 7-bit addressing format is selected. In this case, only the high-order 7 bits (slave address) of the I<sup>2</sup>C address register (address 0323<sub>16</sub>,0333<sub>16</sub>) are compared with address data. When this bit is set to “1”, the 10-bit addressing format is selected, and all the bits of the I<sup>2</sup>C address register are compared with address data.

### •Bit 6: I<sup>2</sup>C-BUS interface reset bit (IHR)

The bit is used to reset I<sup>2</sup>C-BUS interface circuit in the case that the abnormal communication occurs.

When the ES0 bit is “1” (I<sup>2</sup>C-BUS interface is enabled), writing “1” to the IHR bit makes a H/W reset.

Flags are processed as follows:

- 1)Set MST = “0”, TRX = “0”, PIN = “1”, BB = “0”, AL = “0”, AAS = “0”, and AD0 = “0”, of I<sup>2</sup>C status register (Address : 0328<sub>16</sub>, 0338<sub>16</sub>)
- 2)The TOF bit of I<sup>2</sup>C control register (Address : 0327<sub>16</sub>,0337<sub>16</sub>) is cleared to “0”
- 3)The interval counter, flags are initialized.

After writing “1” to IHR bit, the circuit reset processing will be finished in Max. 2.5 V<sub>IIC</sub> cycles and IHR bit will be automatically cleared to “0”. Fig.GC-6 shows the reset timing.

### •Bit 7: I<sup>2</sup>C-BUS interface pin input level selection bit

This bit selects the input level of the SCL and SDA pins of the multi-master I<sup>2</sup>C-BUS interface. When this bit is set to “1” the P60,P61,P62,P63 will become SMBus input level.

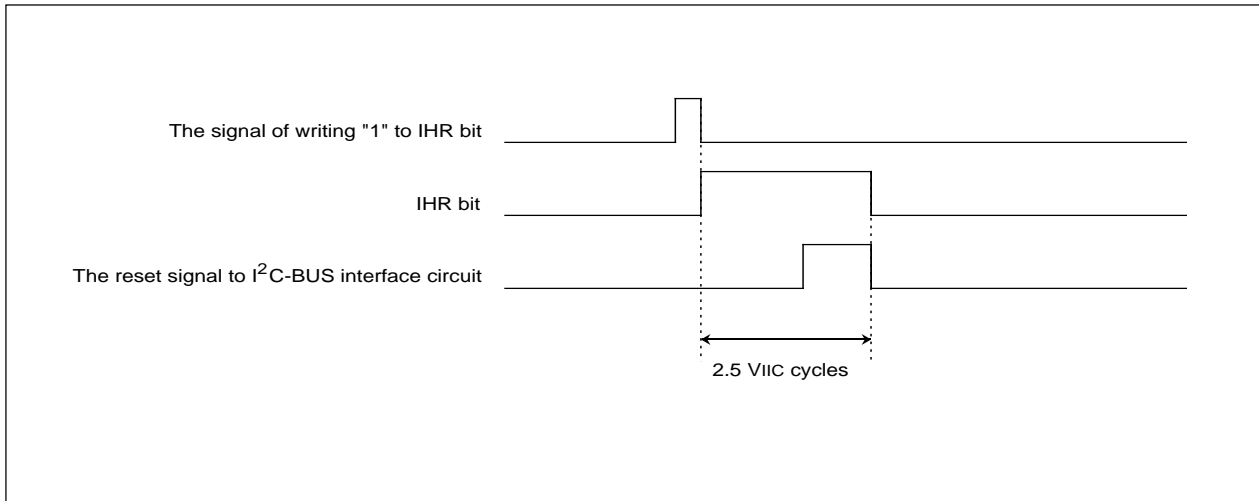

Fig.GC-6 The timing of reset to the I<sup>2</sup>C-BUS interface circuit

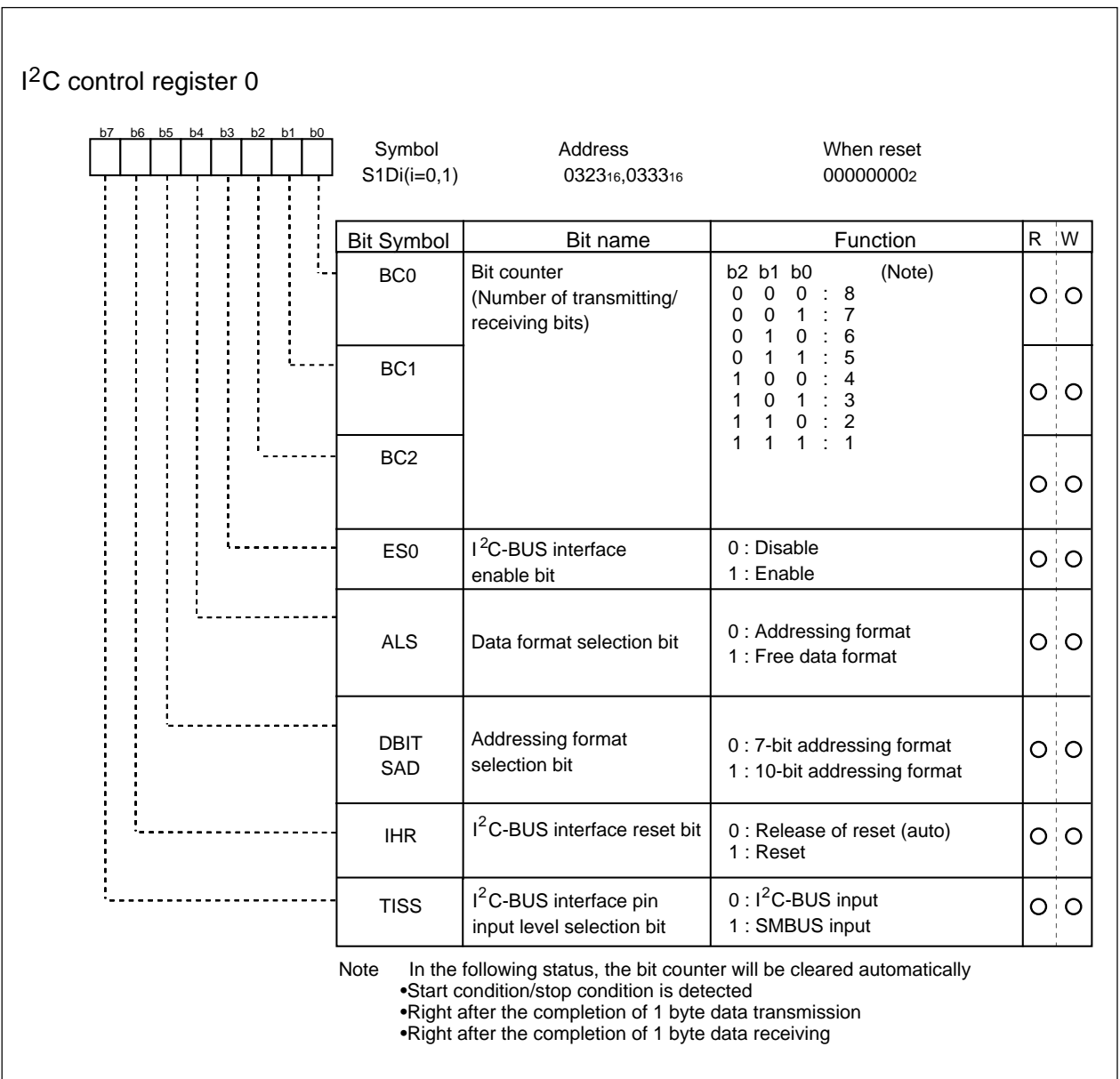

Fig.GC-7 I<sup>2</sup>C control register

## I<sup>2</sup>C Status Register

The I<sup>2</sup>C status register (address 0328<sub>16</sub>,0338<sub>16</sub>) controls the I<sup>2</sup>C-BUS interface status. The low-order 6 bits are read-only if it is used for status check. The high-order 2 bits can be both read and written. Regarding to the function of writing to the low-order 6 bits, refer to the the method of start condition/stop condition generation described later.

### •Bit 0: Last receive bit (LRB)

This bit stores the last bit value of received data and can also be used for ACK receive confirmation. If ACK is returned when an ACK clock occurs, the LRB bit is set to "0". If ACK is not returned, this bit is set to "1". Except in the ACK mode, the last bit value of received data is input. The bit will be "0" by executing a write instruction to the I<sup>2</sup>C data shift register (address 0320<sub>16</sub>,0330<sub>16</sub>).

### •Bit 1: General call detecting flag (AD0)

When the ALS bit is "0", this bit is set to "1" when a general call\* whose address data is all "0" is received in the slave mode. By a general call of the master device, every slave device receives control data after the general call. The AD0 bit is set to "0" by detecting the STOP condition, START condition, or ES0 is "0", or reset.

\*General call: The master transmits the general call address "00<sub>16</sub>" to all slaves.

### •Bit 2: Slave address comparison flag (AAS)

This flag indicates a comparison result of address data when the ALS bit is "0".

1)In the slave receive mode, when the 7-bit addressing format is selected, this bit is set to "1" in one of the following conditions:

- The address data, which following the start conduction, is same with upper bits data of I<sup>2</sup>C address register(Address 00322<sub>16</sub>,0332<sub>16</sub>)
- A general call is received.

2)In the slave reception mode, when the 10-bit addressing format is selected, this bit is set to "1" with the following condition:

- When the address data is compared with the I<sup>2</sup>C address register (8 bits consisting of slave address and RBW bit), the first bytes agree.

3)This bit is set to "0" by executing a write instruction to the I<sup>2</sup>C data shift register (address 0320<sub>16</sub>, 0330<sub>16</sub>) when ES0 is set to "1". The bit is also set to "0" when ES0 is set to "0" or when reset.

### •Bit 3: Arbitration lost\* detecting flag (AL)

In the master transmission mode, when the SDA is made "L" by any other device, arbitration is judged to have been lost, so that this bit is set to "1". At the same time, the TRX bit is set to "0". Immediately after transmission of the byte whose arbitration was lost is completed, the MST bit is set to "0". The arbitration lost can be detected only in the master transmission mode. When arbitration is lost during slave address transmission, the TRX bit is set to "0" and the reception mode is set. Consequently, it becomes possible to detect the agreement between its own slave address and address data transmitted by another master device. The bit is cleared to "0" if writing to I<sup>2</sup>C data shift register (address 0320<sub>16</sub>, 0330<sub>16</sub>) when ES0 is "1".

The bit is also cleared to "0" when ES0 is set to "0" or when reset.

\*Arbitration lost: The status in which communication as a master is disabled.



**•Bit 4: I<sup>2</sup>C-BUS interface interrupt request bit (PIN)**

This bit generates an interrupt request signal. After each byte data is transmitted, the PIN bit changes from “1” to “0”. At the same time, an I<sup>2</sup>C interrupt request signal occurs to the CPU. The PIN bit is set to “0” synchronized with the falling edge of the last internal transmitting clock (including the ACK clock) and an interrupt request signal occurs synchronized with the falling edge of the PIN bit. When the PIN bit is “0”, the SCL is kept in the “0” state and clock generation is disabled. In the ACK clock enable mode, if WIT bit (bit 1 of I<sup>2</sup>C control register 1) is set to “1”, synchronized with the falling edge of last bit clock and ACK clock, PIN bit becomes to “0” and I<sup>2</sup>C interrupt request is generated (Refer to the description on bit 1 of I<sup>2</sup>C control register 1: the data reception completion interrupt enable bit). Fig.GC-9 shows the timing of I<sup>2</sup>C interrupt request generation. The bit is read-only, the value should be “0” in writing.

The PIN bit is set to “0” in one of the following condition:

- Executing a write instruction to the I<sup>2</sup>C data shift register (address 0320<sub>16</sub>,0330<sub>16</sub>).
- Executing a write instruction to the I<sup>2</sup>C clock control register (Address : 0324<sub>16</sub>,0334<sub>16</sub>)  
(only when WIT is “1” and internal WAIT flag is “1”)
- When the ES0 bit is “0”
- At reset

The PIN bit is set to “0” in one of the following condition:

- Immediately after the completion of 1-byte data transmission (including arbitration lost is detected)
- Immediately after the completion of 1-byte data reception
- In the slave reception mode, with ALS = “0” and immediately after the completion of slave address agreement or general call address reception
- In the slave reception mode, with ALS = “1” and immediately after the completion of address data reception

**•Bit 5: Bus busy flag (BB)**

This bit indicates the in-use status the bus system. When this bit is set to “0”, bus system is not busy and a START condition can be generated. The BB flag is set/reset by the SCL, SDA pins input signal regardless of master/slave. This flag is set to “1” by detecting the start condition, and is set to “0” by detecting the stop condition. The condition of the detecting is set by the start/stop condition setting bits (SSC4–SSC0) of the I<sup>2</sup>C start/stop condition control register (address 0325<sub>16</sub>,0335<sub>16</sub>). When the ES0 bit (bit 3) of the I<sup>2</sup>C control register (address 0323<sub>16</sub>,0333<sub>16</sub>) is “0” or reset, the BB flag is set to “0”. For the writing function to the BB flag, refer to the sections “START Condition Generating Method” and “STOP Condition Generating Method” described later.

**•Bit 6: Communication mode specification bit (transfer direction specification bit: TRX)**

This bit decides a direction of transfer for data communication. When this bit is “0”, the reception mode is selected and the data from a transmitting device is received. When the bit is “1”, the transmission mode is selected and address data and control data are output onto the SDA synchronized with the clock generated on the SCL. This bit can be set/reset by software or hardware. This bit is set to “1” by hardware in the following condition:

In slave mode with ALS = “0”, if the AAS flag is set to “1” after the address data reception and the received R/W bit is “1”.

This bit is set to “0” by hardware in one of the following conditions:

- When arbitration lost is detected.
- When a STOP condition is detected.
- When a start condition is prevented by the start condition duplication preventing function (**Note**).
- When a start condition is detected with MST = “0”.
- When ACK non-return is detected with MST = “0”.
- When ES0 = “0”.
- At reset

•**Bit 7: Communication mode specification bit (master/slave specification bit: MST)**

This bit is used for master/slave specification for data communication. When this bit is "0", the slave is specified, so that a START condition and a STOP condition generated by the master are received. The data communication is performed synchronized with the clock generated by the master. When this bit is "1", the master is specified and a START condition and a STOP condition are generated.

Additionally, the clocks required for data communication are generated on the SCL.

This bit is set to "0" by hardware in one of the following conditions.

- Immediately after the completion of 1-byte data transfer when arbitration lost is detected.
- When a STOP condition is detected.
- Writing a start condition is prevented by the start condition duplication preventing function (**Note**).
- At reset

**Note:** START condition duplication preventing function The MST, TRX, and BB bits is set to "1" at the same time after confirming that the BB flag is "0" in the procedure of a START condition occurrence.

However, when a START condition by an other master device occurs and the BB flag is set to "1" immediately after the contents of the BB flag is confirmed, the START condition duplication preventing function makes the writing to the MST and TRX bits invalid. The duplication preventing function becomes valid from the rising of the BB flag to reception completion of slave address. Refer to the method on the start condition generation in detail.

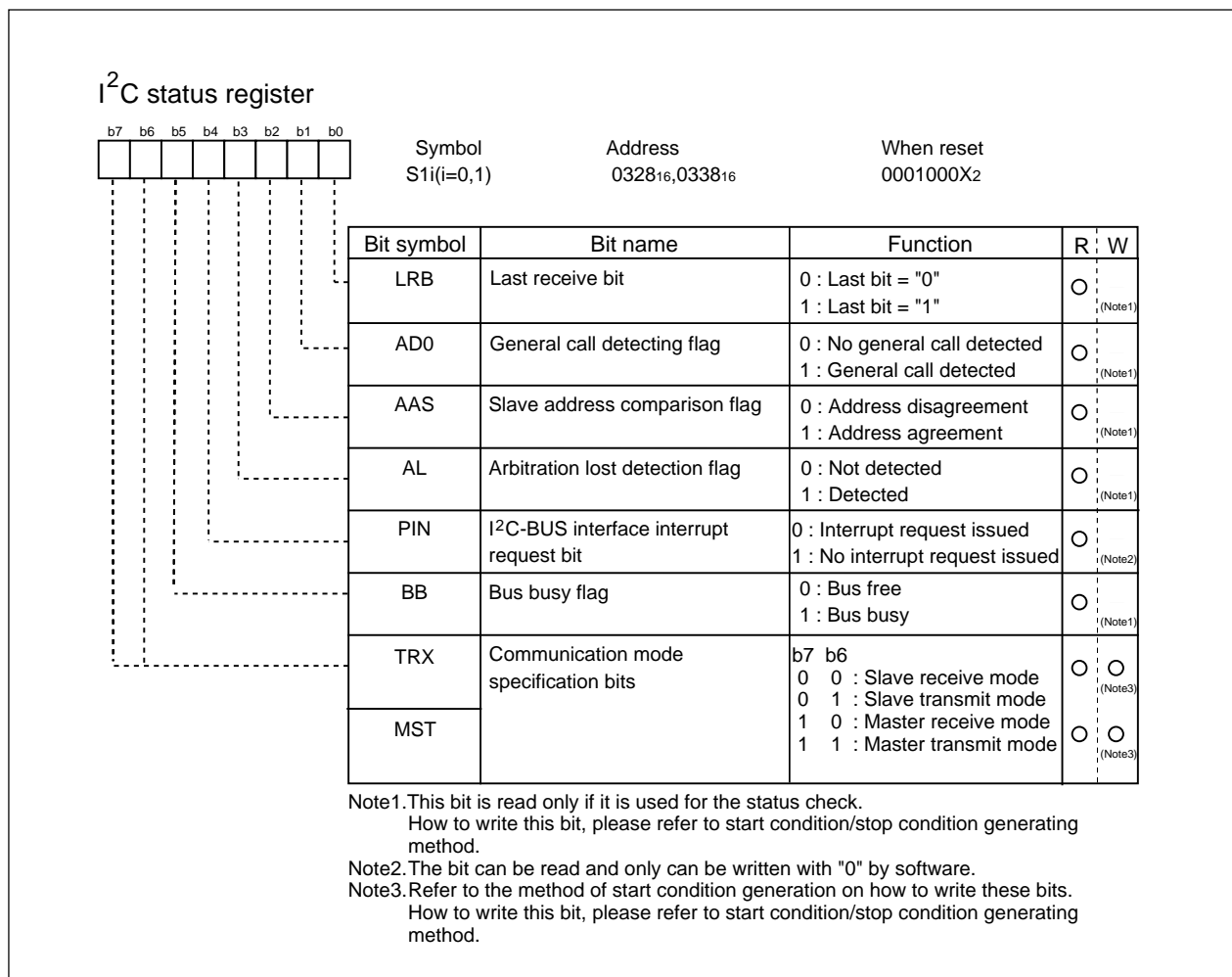

Fig.GC-8 I<sup>2</sup>C status register

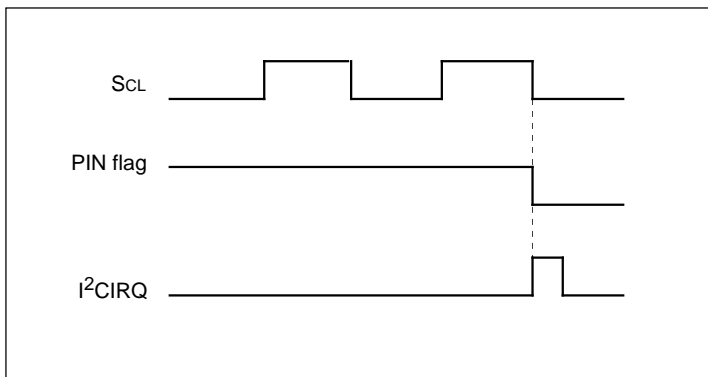

Fig.GC-9 Interrupt request signal generating timing

**I<sup>2</sup>C0, I<sup>2</sup>C1 control register 1**

I<sup>2</sup>C control register 10 ,11 (address 032616,033616) controls I<sup>2</sup>C-BUS interface circuit.

**•Bit 0 : Interrupt enable bit by STOP condition (SIM )**

It is possible for I<sup>2</sup>C-BUS interface to request an interrupt by detecting a STOP condition. If the bit set to “1”, an interrupt from I<sup>2</sup>C-BUS interface occurs by detecting a STOP condition ( There is no change for PIN flag)

**•Bit 1: Interrupt enable bit at the completion of data receiving (WIT)**

When with-ACK mode (ACK bit = “1”) is specified, by enabling the interrupt at the completion of data receiving (WIT bit = “1”), the I<sup>2</sup>C interrupt request occurs and PIN bit becomes “0” synchronized with the falling edge of last data bit clock. SCL is fixed “L” and the generation of ACK clock is suppressed.

Table GC-3 and Fig.GC-10 show the I<sup>2</sup>C interrupt request timing and the method of communication restart. After the communication restart, synchronized with the falling edge of ACK clock, PIN bit becomes to “0” and I<sup>2</sup>C interrupt request occurs.

**Table.GC-3 Timing of interrupt generation in data receiving**

The timing of I <sup>2</sup> C interrupt generation	The method of communication restart
1)Synchronized with the falling edge of the last data bit clock	The execution of writing to ACKBIT of I <sup>2</sup> C clock control register. (Do not write to I <sup>2</sup> C data shift register. The processing of ACK clock would be incorrect.)
2)Synchronized with the falling edge of the ACK clock	The execution of writing to I <sup>2</sup> C data shift register

The state of internal WAIT flag can be read out by reading the WIT bit. The internal WAIT flag is set after writing to I<sup>2</sup>C data shift register, and it is reset after writing to I<sup>2</sup>C clock control register. Consequently, which of the timing 1) and 2) of interrupt request occurring can be understood. (See Fig.GC-10)In the cases of transmission and address data reception immediately after the START condition, the interrupt request only occurs at the falling edge of ACK clock regardless of the value of WIT bit and the WAIT flag remains the reset state. Write “0” to WIT bit when in NACK is specified. (ACK bit = “0”)

### •Bits 2,3 : Port function selection bits PED, PEC

When ES0 bit of I<sup>2</sup>C control register 0 is set to "1", P61/P63 and P60/P62 function as SCL and SDA respectively. However, if PED is set to "1", SDA functions as output port so as to SCL if PEC is set to "1". In this case, if "0" or "1" is written to the port register, the data can be output on to the I<sup>2</sup>C-BUS regardless of the internal SCL/SDA output signals. The functions of SCL/SDA are returned back by setting PED/PEC to "1" again.

If the ports are set in input mode, the values on the I<sup>2</sup>C-BUS can be known by reading the port register regardless of the values of PED and PEC. Table GC-4 shows the port specification.

**Table.GC-4 Ports specifications**

Pin name	ES0 bit	PED bit	P6 port direction register	Function
P60/P62	0	-	0/1	Port I/O function
	1	0	-	SDA I/O function
	1	1	-	SDA input function, port output function
P61/P63	ES0 bit	PEC bit	P6 port direction register	Function
	0	-	0/1	Port I/O function
	1	0	-	SCL I/O function
	1	1	-	SCL input function, port output function

### •Bits 4,5 : SDA/SCL logic output value monitor bits SDAM /SCLM

It is possible to monitor the logic value of the SDA and SCL output signals from I<sup>2</sup>C-BUS interface circuit. SDAM can monitor the output logic value of SDA. SCLM can monitor the output logic value of SCL. The bits are read-only. Write "0" if in writing (Writing "1" is reserved)

### •Bits 6,7 : I<sup>2</sup>C system clock selection bits ICK0, ICK1

These bits select the basic operation clock of I<sup>2</sup>C-BUS interface circuit. It is possible to select I<sup>2</sup>C system clock V<sub>IIC</sub> among 1/2, 1/4 and 1/8 of main clock f(X<sub>IN</sub>) and 1/2 of external I<sup>2</sup>C clock (ICCK)

**Table.GC-5 I<sup>2</sup>C system clock selecting bits**

ICK1	ICK0	I <sup>2</sup> C system clock
0	0	V <sub>IIC</sub> = 1 / 2f <sub>1</sub>
0	1	V <sub>IIC</sub> = 1 / 4f <sub>1</sub>
1	0	V <sub>IIC</sub> = 1 / 8f <sub>1</sub>
1	1	V <sub>IIC</sub> = 1 / 2ICCK

Note: f<sub>1</sub> = f(X<sub>IN</sub>)

ICCK = External I<sup>2</sup>C clock

•The address reception in STOP mode /WAIT mode

It is possible for I<sup>2</sup>C-BUS interface to receive address data even in STOP mode or in WAIT mode. However the I<sup>2</sup>C system clock V<sub>II</sub>C should be supplied. Table.GC-6 shows the setting list.

**Table.GC-6 Clock setting to the I<sup>2</sup>C system in different operation mode.**

Mode	The setting content
STOP mode	The external clock is selected as the I <sup>2</sup> C system clock ( ICK1 = 1, ICK0 = 1) and the external I <sup>2</sup> C clock is supplied by ICCK.
WAIT mode	The external clock is selected as the I <sup>2</sup> C system clock ( ICK1 = 1, ICK0 = 1) and the external I <sup>2</sup> C clock is supplied by ICCK. Select the peripheral function clock stop bit CMO2 (bit 2 of the system clock control register 0, address : 000616) to the state of not stopping f1,f8,f32 (CMO2 = 0) when in WAIT mode, and then execute the WAIT command.
Low power consumption mode	The external clock is selected as the I <sup>2</sup> C system clock ( ICK1 = 1, ICK0 = 1) and the external I <sup>2</sup> C clock is supplied by ICCK.

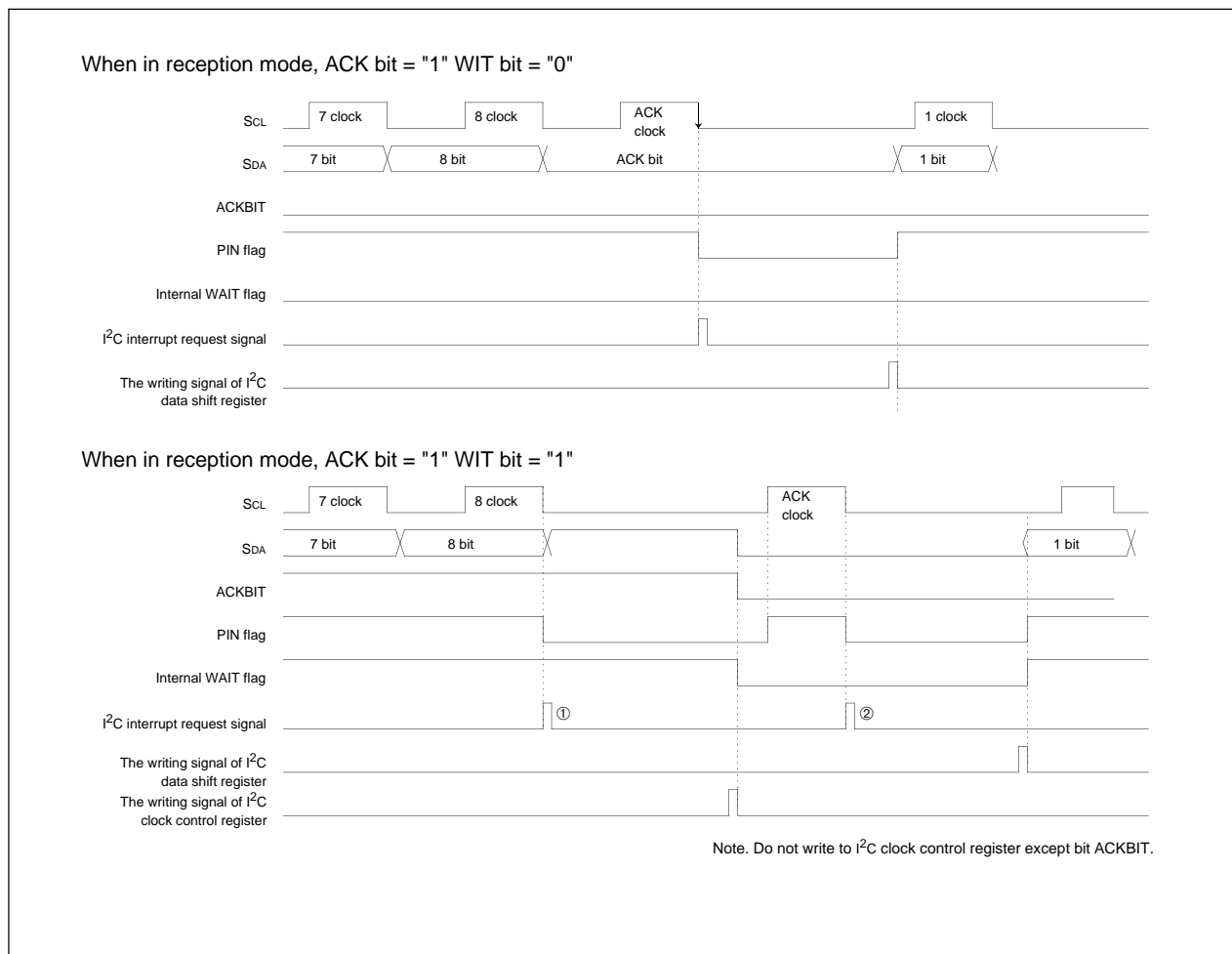

**Fig.GC-10 The timing of the interrupt generation at the completion of data reception**

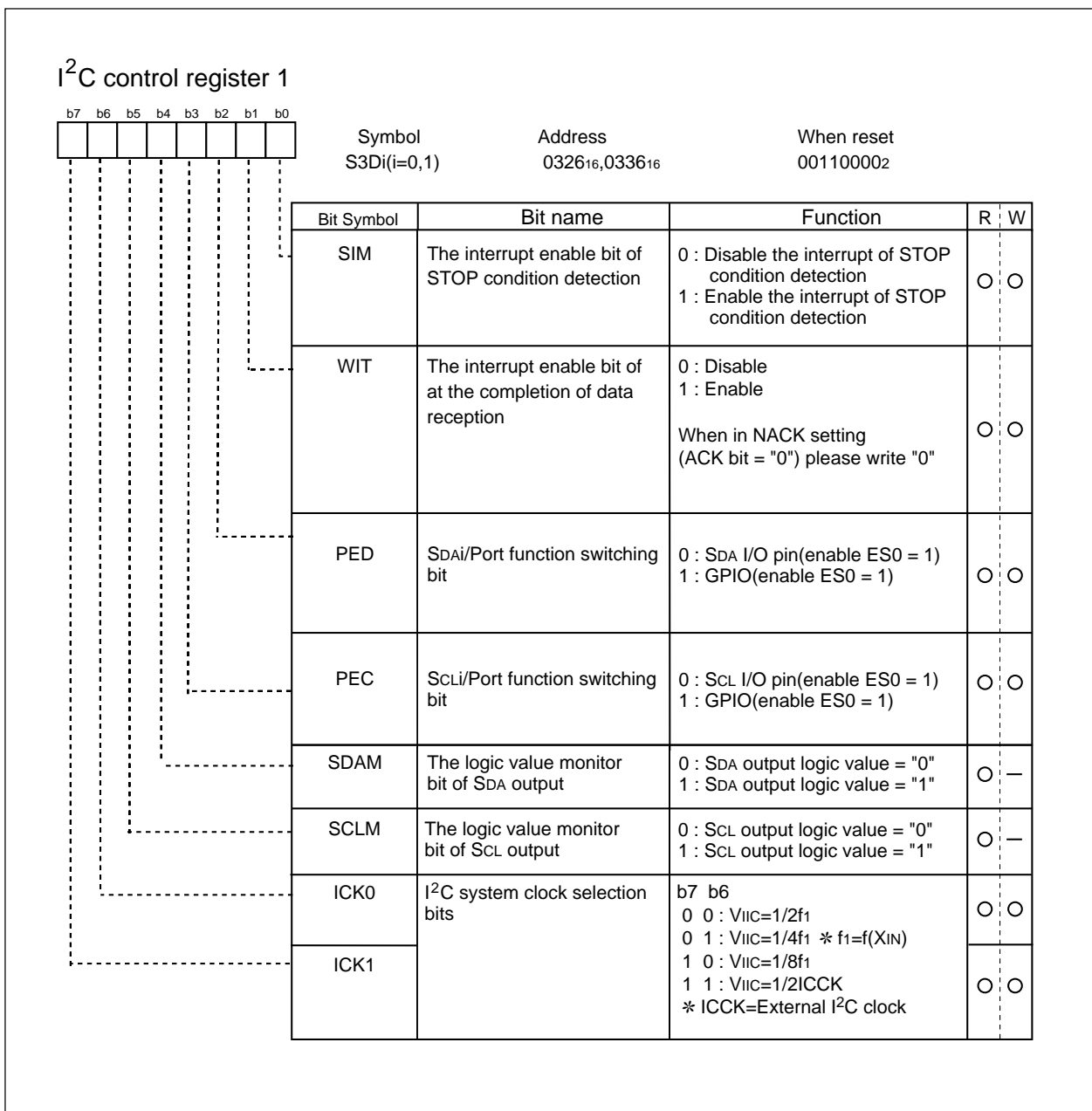

Fig.GC-11 I<sup>2</sup>C control register 1

## I<sup>2</sup>C control register 2

I<sup>2</sup>C0, 1 control register 2 (address: 032716,033716) control the detection of communication abnormality. In I<sup>2</sup>C-BUS communication, the data transfer is controlled by the SCL clock signal. The devices will stop in the communication state if SCL stops during transfer. So if the SCL clock stops in "H" state for a period of time, the I<sup>2</sup>C-BUS interface circuit can detect the time out and request an I<sup>2</sup>C interrupt. Please see Fig.GC-12.

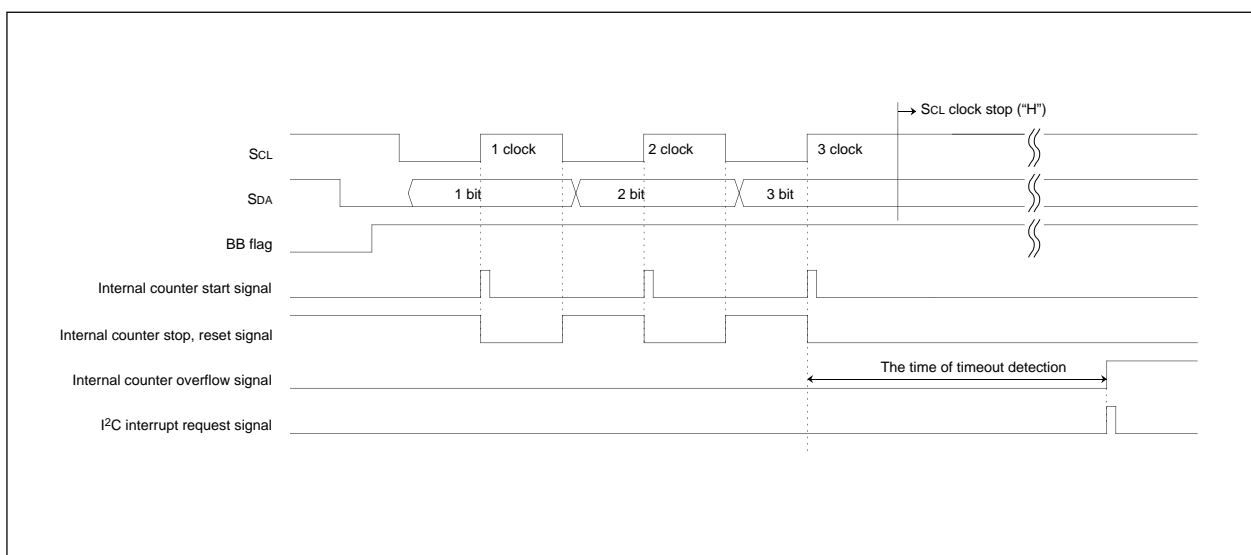

Fig.GC-12 The timing of timeout detection

### •Bit0: Time out detection function enable bit (TOE)

The bit enables timeout detection function. By setting this bit to "1", the I<sup>2</sup>C interrupt request signal will be generated if the SCL clock stops in "H" state for a period of time during bus busy (BB flag = "1").

The time of time out detection which is selected by timeout detection time selection bit (TOSEL) with long time mode or short time mode will be calculated by internal counter. When time out is detected, please set "0" to I<sup>2</sup>C-BUS interface enable bit (ES0) and then process initialization.

### •Bit1: Time out detection flag (TOF)

The bit is the flag showing timeout detection status. If the time which is calculated by the internal counter overflows, the time out detection flag (TOF) becomes to "1", and at the same time the I<sup>2</sup>C interrupt request signal is generated.

### •Bit2: timeout detection time selection bit (TOSEL)

The bit selects timeout detection time from long time and short time mode. If TOSEL = "0", the long time mode; TOSEL = "1", the short mode is selected respectively. The long time is up counted by 16 bits counter and the short time is up counted by 14 bits counter based on I<sup>2</sup>C system clock (V<sub>IIC</sub>). Table GC-7 shows examples of the timeout detection time.

Table.GC-7 Examples of timeout detection time (Unit: ms)

V <sub>IIC</sub> (MHz)	Long time mode	Short time mode
4	16.4	4.1
2	32.8	8.2
1	65.6	16.4

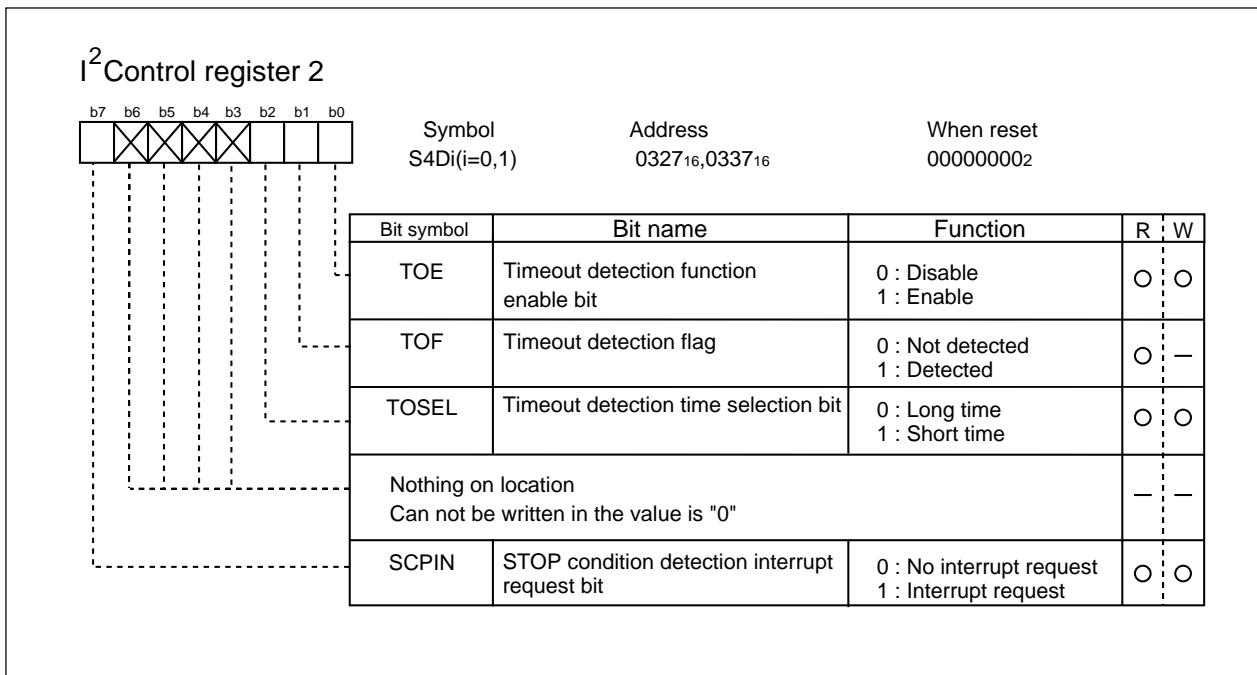

Fig.GC-13 I<sup>2</sup>C control register 2

•Bit7: STOP condition detection interrupt request bit (SCPIN)

The bit monitors the stop condition detection interrupt. The bit becomes to "1" when I<sup>2</sup>C-BUS interface interrupt is generated by the detecting of STOP condition. Writing "0" clears the bit and "1" can not be written.

## I<sup>2</sup>C START/STOP condition control register

I<sup>2</sup>C START/STOP condition register(address 032516,033516) controls the detection of START/STOP condition.

### •Bit0-Bit4: START/STOP condition setting bits (SSC4-SSC0)

Because the release time, set up time and hold time of SCL is calculated on the base of I<sup>2</sup>C system clock(V<sub>IIC</sub>), the detecting condition changes depending on the oscillation frequency and I<sup>2</sup>C system clock selecting bits. It is necessary to set the suitable value of START/STOP condition setting bits (SSC4-SSC0) so that obtain the release time, set up time and hold time corresponding to the system clock frequency. Refer to Table GC-11. Do not set odd number or "000002" to START/STOP condition setting bits. The recommended setting value to START/STOP condition setting bits (SSC4-SSC0) at each oscillation frequency under standard clock mode is shown in Table. GC-8. The detection of START/STOP condition starts immediately after the setting of ES0=1.

### •Bit5: SCL/SDA interrupt pin polarity selection bit (SIP)

The interrupt can be generated by detecting the rising edge or the falling edge of SCL pin or SDA pin. SCL/SDA interrupt pin polarity selection bit selects the polarity of SCL pin or SDA pin for interrupt.

### •Bit6 : SCL/SDA interrupt pin selection bit (SIS)

SCL/SDA interrupt pin selection bit selects either SCL pin or SDA pin as SCL/SDA interrupt enable pin.

Note: The SCL/SDA interrupt request may be set when the setting of I<sup>2</sup>C-BUS interface enable bit ES0 changes.

Thus set the interrupt disable before the setting of SCL/SDA interrupt pin polarity selection bit (SIP) and SCL/SDA interrupt selection bit(SIS). After that reset "0" to the interrupt request bit before enabling the interrupt.

### •Bit7: START/STOP condition generation selecting bit (STSPSEL)

The bit selects the length of set up/hold time when START/STOP condition occurs. The length of set up/hold time is based on the I<sup>2</sup>C system clock cycles. Refer to Table GC-9. Set the bit to "1" if I<sup>2</sup>C system clock frequency is over 4MHz.

Fig.GC-14 I<sup>2</sup>C start/stop condition control register

Table.GC-8 Recommended setting value (SSC4 - SSC0) start/stop condition at each oscillation frequency

Oscillation f(XIN) (MHz)	I <sup>2</sup> C system clock selection	I <sup>2</sup> C system clock(MHz)	SSC4-SSC0	SCL release time(cycle)	Setup time (cycle)	Hold time (cycle)
10	1 / 2f <sub>1</sub>	5	XXX11110	6.2μs (31)	3.2μs (16)	3.0μs (15)
8	1 / 2f <sub>1</sub>	4	XXX11010	6.75μs(27)	3.5μs (14)	3.25μs(13)
			XXX11000	6.25μs(25)	3.25μs(13)	3.0μs (12)
8	1 / 8f <sub>1</sub>	1	XXX00100	5.0μs (5)	3.0μs (3)	2.0μs (2)
4	1 / 2f <sub>1</sub>	2	XXX01100	6.5μs (13)	3.5μs (7)	3.0μs (6)
			XXX01010	5.5μs (11)	3.0μs (6)	2.5μs (5)
2	1 / 2f <sub>1</sub>	1	XXX00100	5.0μs (5)	3.0μs (3)	2.0μs (2)

Note: Do not set odd value or "000002" to START/STOP condition setting bits

### START Condition Generation Method

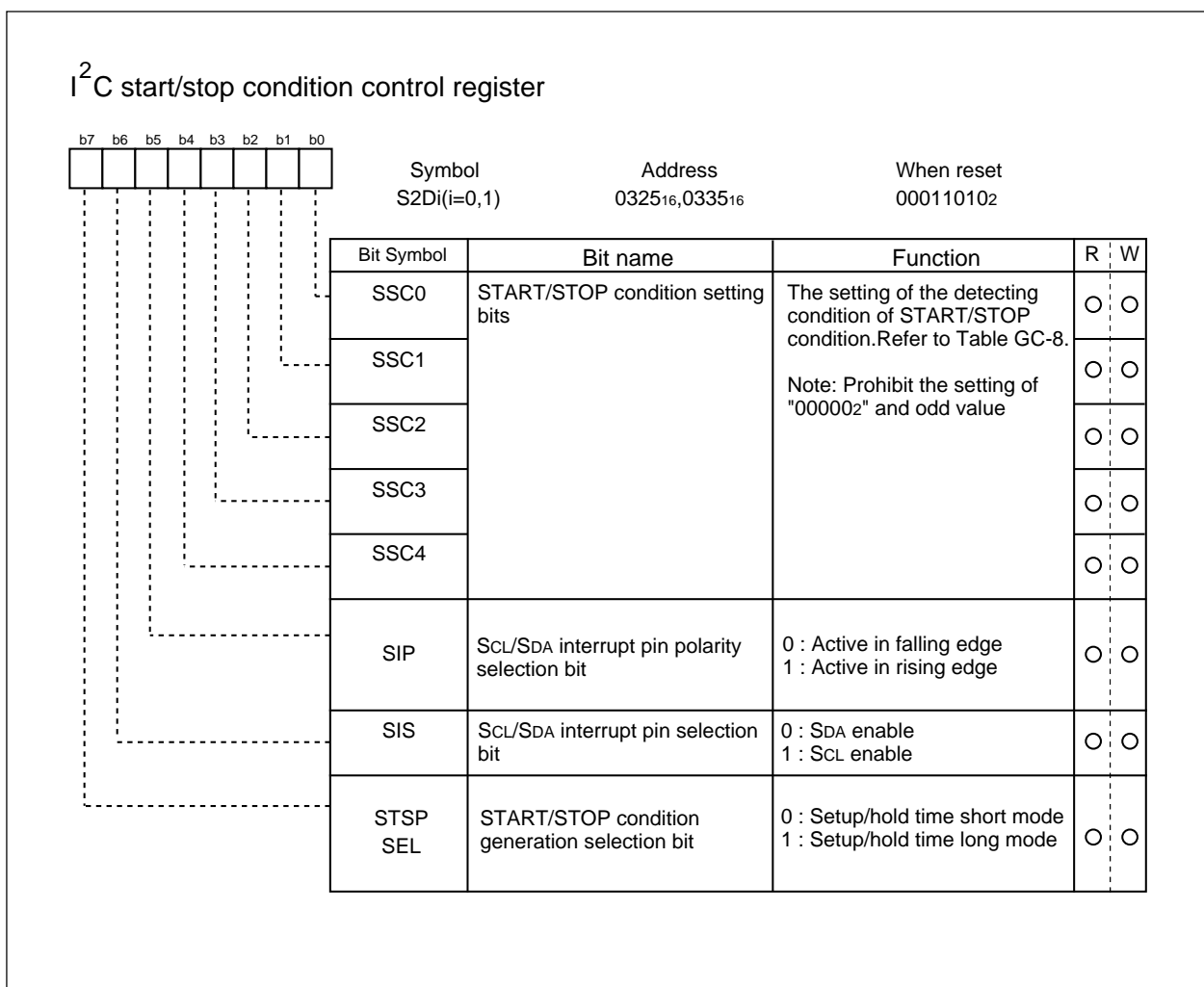
When ES0 bit of the I<sup>2</sup>C control register is "1" and the BB flag of I<sup>2</sup>C status register is "0", writing "1" to the MST, TRX, and BB bits and "0" to the PIN and low-order 4 bits of the I<sup>2</sup>C status register (address 032816, 033816) simultaneously enters the standby status to generate the start condition. The start condition is generated after writing slave address data to the I<sup>2</sup>C data shift register. After that, the bit counter becomes "0002" and 1 byte SCL are output. The START condition generation timing is different in the standard clock mode and the high-speed clock mode. Refer to Fig.GC-17 the START condition generation timing diagram, and Table GC-9 the START condition generation timing table.

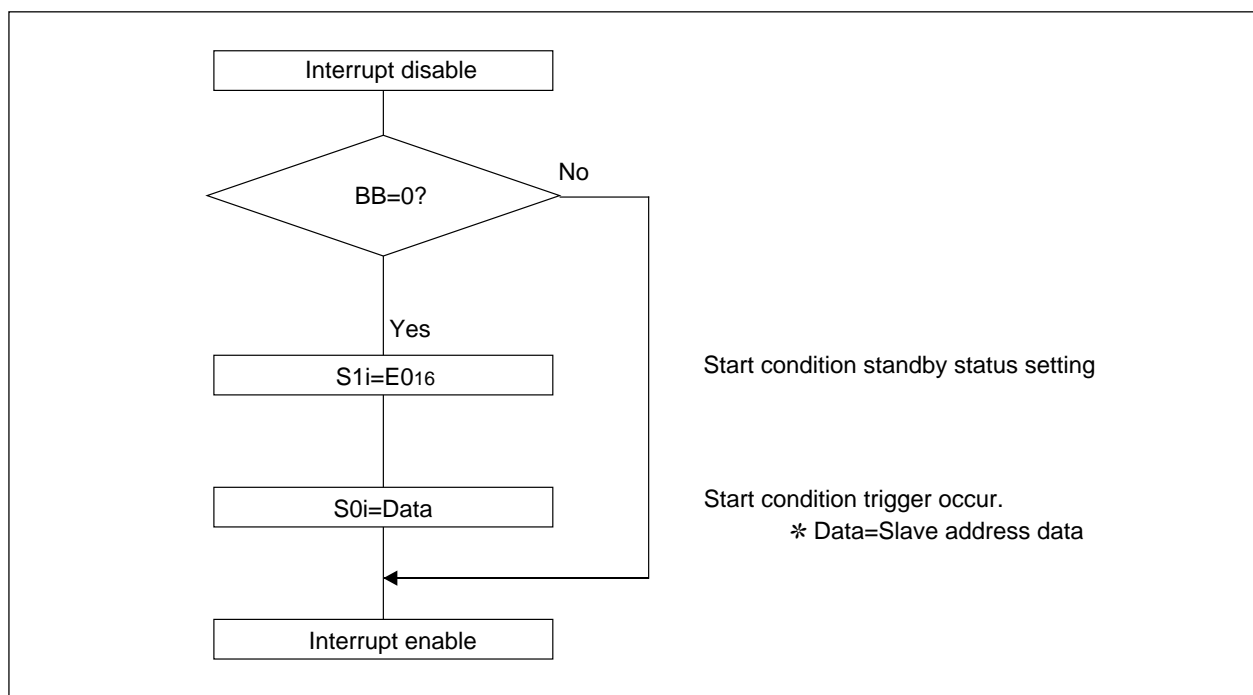

Fig.GC-15 Start condition generation flow chart

### Function of protection of duplicate START condition

It is necessary to verify that the bus is not in use via BB flag before setting up a START Condition. However, there is a possibility that right after the verification of BB flag, the BB flag becomes to "1" because a START condition is generated by another master device. In this case, the function to interrupt the start condition is built in. When the function starts, it works as follows:

- The prohibition of setting up START condition standby

If the START condition standby has been set up, releases it and resets the bits of MST and TRX.

- The prohibition of writing to the I<sup>2</sup>C data shift register (The prohibition of generating a START condition trigger)
- If the generation of start condition is interrupted, sets the AL flag.

The function of protection of duplicate START condition is valid from the falling edge of SDA of START condition to the completion of slave reception. Fig.GC-16 shows the valid period of the function of protection of duplicate START condition.

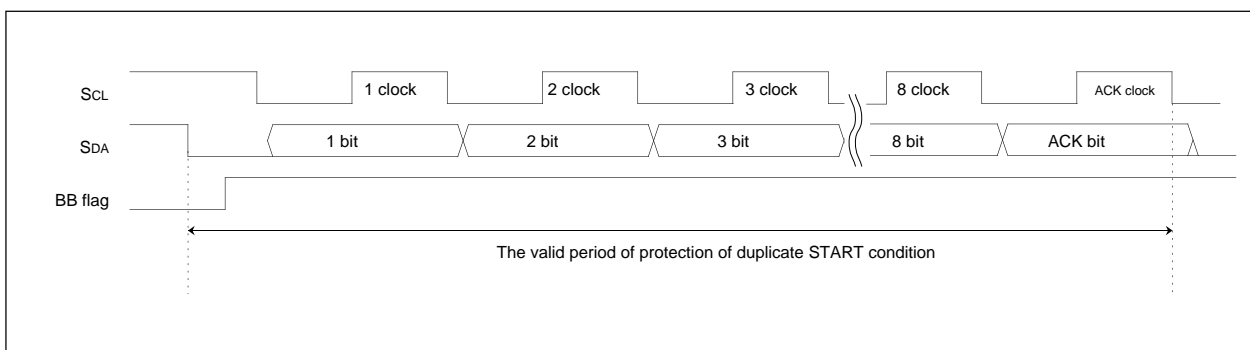

**Fig.GC-16 The valid period of the function of protection of duplicate START condition**

## STOP Condition Generation Method

When the ES0 bit of the I<sup>2</sup>C control register is "1", writing "1" to the MST and TRX bits, and "0" to the BB, PIN and low-order bits of the I<sup>2</sup>C status register simultaneously enters the standby status to generate the stop condition. The stop condition is generated after writing dummy data to the I<sup>2</sup>C data shift register. The STOP condition generation timing is different in the standard clock mode and the high-speed clock mode. Refer to Fig.GC-18, the STOP condition generation timing diagram, and Table GC-9, the STOP condition generation timing table. Do not write data to I<sup>2</sup>C status register and I<sup>2</sup>C data shift register, before BB flag becomes to "0" after the instruction to generate the stop condition to avoid the influence on generating STOP condition waveform.

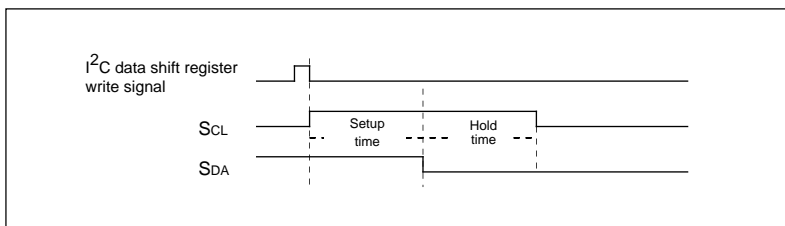

Fig.GC-17 Start condition generation timing diagram

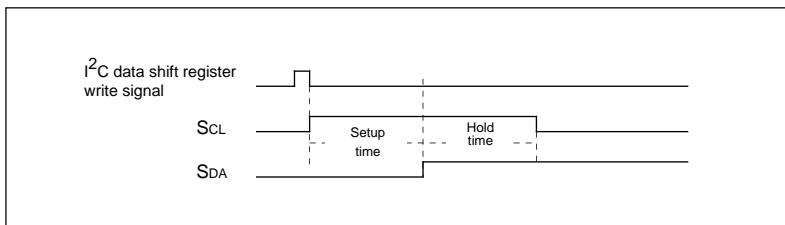

Fig.GC-18 Stop condition generation timing diagram

Table.GC-9 Start/Stop generation timing table

Item	Start/Stop condition generation selection bit	Standard clock mode	High-speed clock mode
Setup time	"0"	5.0μs (20 cycle)	2.5μs (10 cycle)
	"1"	13.0μs (52 cycle)	6.5μs (26 cycle)
hold time	"0"	5.0μs (20 cycle)	2.5μs (10 cycle)
	"1"	13.0μs (52 cycle)	6.5μs (26 cycle)

Note: VIIC = 4MHz

As mentioned above, Writing "1" to MST and TRX bits.

Writing "1" or "0" to BB bit, writing "0" to PIN and low-order 4 bits, simultaneously sets up the START or STOP condition standby. It releases SDA in START condition standby, makes SDA to "L" in STOP condition standby. The signal of writing to data shift register triggers the generation of START/STOP condition. In the case of setting MST, and TRX to "1" but do not want to generate a START/STOP condition. Write "1" to the low-order 4 bits simultaneously. Fig.GC-10 illustrates the function of writing to status register.

Table.GC-10 The function of writing to status register

The value of the data writing to status register								Function
MST	TRX	BB	PIN	AL	AAS	AS0	LRB	
1	1	1	0	0	0	0	0	Setting up the START condition stand by in master transmission mode
1	1	0	0	0	0	0	0	Setting up the STOP condition stand by in master transmission mode
0/1	0/1	-	0	1	1	1	1	Setting up the communication mode (refer to the description on I <sup>2</sup> C status register)

## START/STOP Condition Detecting Operation

The START/STOP condition detection operations are shown in Fig.GC-19, GC-20 and Table.GC-11. The START/STOP condition is set by the START/STOP condition set bit. The START/STOP condition can be detected only when the input signal of the SCL and SDA pins satisfy with three conditions: SCL release time, setup time, and hold time (see Table.GC-11). The BB flag is set to "1" by detecting the START condition and is reset to "0" by detecting the STOP condition. The BB flag set/reset timing is different in the standard clock mode and the high-speed clock mode. Refer to Table GC-11, the BB flag set/reset time.

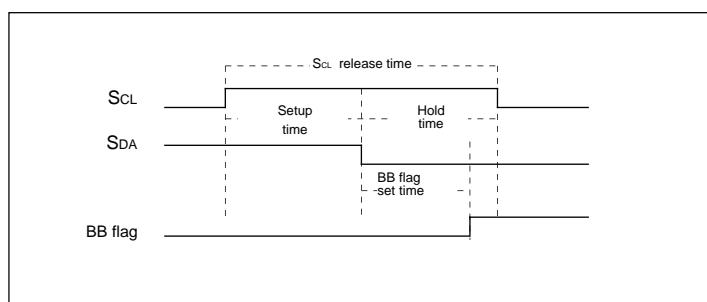

Fig.GC-19 Start condition detection timing diagram

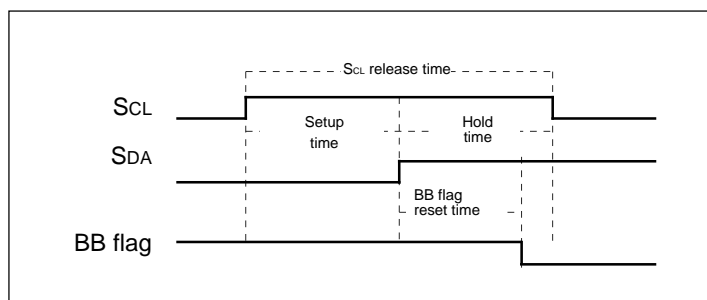

Fig.GC-20 Stop condition detection timing diagram

Table.GC-11 Start/Stop generation timing table

	Standard clock mode	High-speed clock mode
SCL release time	SSC value + 1 cycle (6.25μs)	4 cycle (1.0μs)
Setup time	$\frac{\text{SSC value}}{2} + 1 \text{ cycle} < 4.0\mu\text{s}$ (3.25μs)	2 cycle (0.5μs)
Hold time	$\frac{\text{SSC value}}{2} \text{ cycle} < 4.0\mu\text{s}$ (3.0μs)	2 cycle (0.5μs)
BB flag set/reset time	$\frac{\text{SSC value} - 1}{2} + 2 \text{ cycle}$ (3.375μs)	3.5 cycle (0.875μs)

**Note:** Unit : Cycle number of system clock V<sub>IIC</sub>

SSC value is the decimal notation value of the START/STOP condition set bits SSC4 to SSC0.

Do not set "0" or an odd number to SSC value. The value in parentheses is an example when the I<sup>2</sup>C START/STOP condition control register is set to "1816" at V<sub>IIC</sub> = 4 MHz.

## Address Data Communication

There are two address data communication formats, namely, 7-bit addressing format and 10-bit addressing format. The respective address communication formats are described below.

### (1) 7-bit addressing format

To adapt the 7-bit addressing format, set the DBIT SAD bit of the I<sup>2</sup>C control register 0 (address 0323<sub>16</sub>,0333<sub>16</sub>) to "0". The first 7-bit address data transmitted from the master is compared with the high-order 7-bit slave address stored in the I<sup>2</sup>C address register (address 0322<sub>16</sub>,0332<sub>16</sub>). At the time of this comparison, address comparison of the RBW bit of the I<sup>2</sup>C address register (address 0322<sub>16</sub>,0332<sub>16</sub>) is not performed. For the data transmission format when the 7-bit addressing format is selected, refer to Fig.GC-21 (1) and (2).

### (2) 10-bit addressing format

To adapt the 10-bit addressing format, set the DBIT SAD bit of the I<sup>2</sup>C control register 0 (address 0323<sub>16</sub>,0333<sub>16</sub>) to "1". Also set the WIT bit of I<sup>2</sup>C control register 1 to "1". An address comparison is performed between the first-byte address data transmitted from the master and the 8-bit slave address stored in the I<sup>2</sup>C address register (address 0322<sub>16</sub>,0332<sub>16</sub>). At the time of this comparison, an address comparison between the RBW bit of the I<sup>2</sup>C address register (address 0320<sub>16</sub>,0330<sub>16</sub>) and the R/W bit which is the last bit of the address data transmitted from the master is made. In the 10-bit addressing mode, the RBW bit which is the last bit of the address data not only specifies the direction of communication for control data, but also is processed as an address data bit.

When the first-byte address data agree with the slave address, the AAS bit of the I<sup>2</sup>C status register (address 0328<sub>16</sub>,0338<sub>16</sub>) is set to "1". After the second-byte address data is stored into the I<sup>2</sup>C data shift register (address 320<sub>16</sub>,330<sub>16</sub>), perform an address comparison between the second-byte data and the slave address by software. When the address data of the 2 bytes agree with the slave address, write "0" to the ACKBIT to I<sup>2</sup>C clock control register, to return an ACK. When the address data of the 2 bytes do not agree with the slave address, it does not return an ACK so that makes the finish of the communication by writing "1" to the ACKBIT. If the address data agree with each other, set the RBW bit of the I<sup>2</sup>C address register (address 0322<sub>16</sub>,0332<sub>16</sub>) to "1" by software. This processing can make the 7-bit slave address and R/W data agree, which are received after a RESTART condition is detected, with the value of the I<sup>2</sup>C address register (address 0322<sub>16</sub>,0332<sub>16</sub>). For the data transmission format when the 10-bit addressing format is selected, refer to Fig.GC-21(3) and (4).



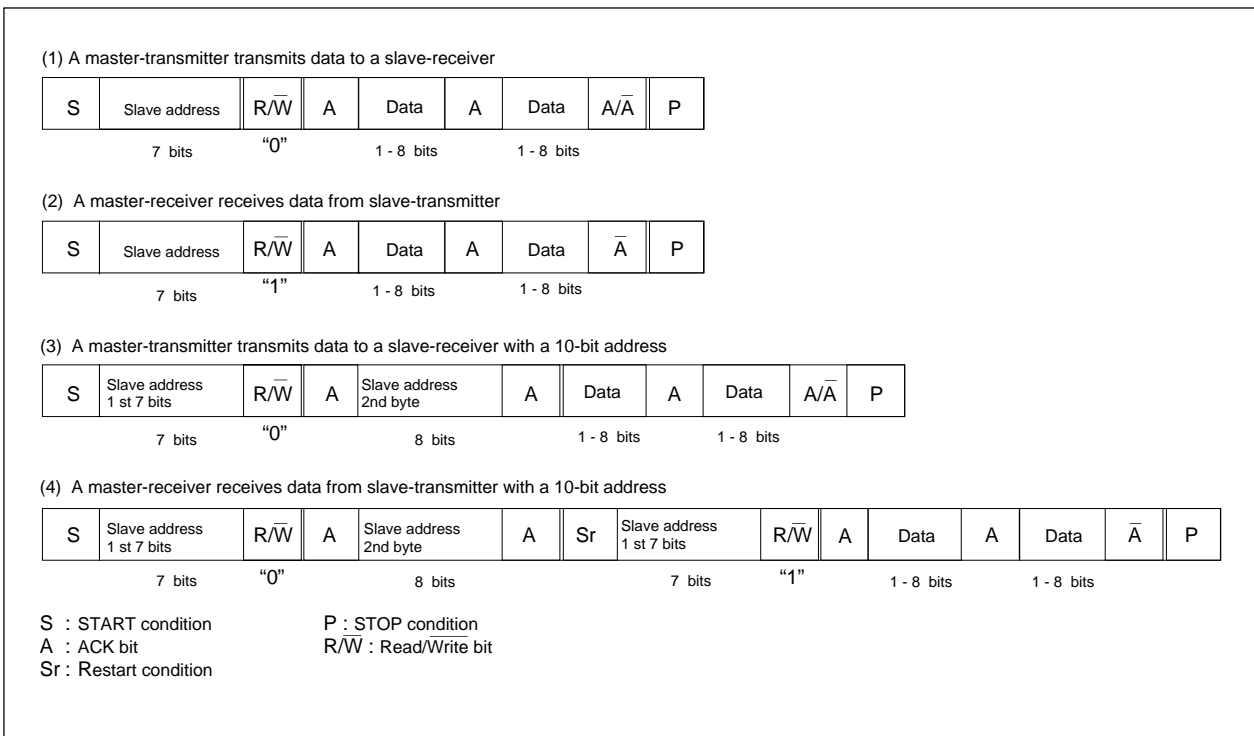

**Fig.GC-21 Address data communication format**

### Example of Master Transmission

An example of master transmission in the standard clock mode, at the SCL frequency of 100 kHz and in the ACK return mode is shown below.

- 1) Set a slave address in the high-order 7 bits of the I<sup>2</sup>C address register and "0" into the RBW bit.
- 2) Set the ACK return mode and SCL = 100 kHz by setting "00<sub>16</sub>" in the I<sup>2</sup>C control register 1 and "85<sub>16</sub>" in the I<sup>2</sup>C clock control register respectively. (f(XIN)=8MHz)
- 3) Set "00<sub>16</sub>" in the I<sup>2</sup>C status register so that transmission/reception mode is initialized.
- 4) Set a communication enable status by setting "08<sub>16</sub>" in the I<sup>2</sup>C control register 0.
- 5) Confirm the bus free condition by the BB flag of the I<sup>2</sup>C status register.
- 6) Set "E0<sub>16</sub>" in the I<sup>2</sup>C status register to setup a standby of START condition.
- 7) Set the destination address data for transmission in high-order 7 bit of I<sup>2</sup>C data shift register and set "0" in the least significant bit. And then a START condition occurs. At this time, SCL for 1 byte and an ACK clock automatically generate.
- 8) Set transmission data in the I<sup>2</sup>C data shift register. At this time, an SCL and an ACK clock automatically generate.
- 9) When transmitting control data of more than 1 byte, repeat step 8).
- 10) Set "C0<sub>16</sub>" in the I<sup>2</sup>C status register to setup a STOP condition if ACK is not returned from slave reception side or transmission ends.
- 11) A STOP condition occurs when writing dummy data to I<sup>2</sup>C data shift register.

### Example of Slave Reception

An example of slave reception in the high-speed clock mode, at the SCL frequency of 400 kHz, in the ACK return mode and using the addressing format is shown below.

- 1) Set a slave address in the high-order 7 bits of the I<sup>2</sup>C address register and "0" in the RBW bit.
- 2) Set the ACK clock mode and SCL = 400 kHz by setting "00<sub>16</sub>" in the I<sup>2</sup>C control register 1 and "A5<sub>16</sub>" in the I<sup>2</sup>C clock control register respectively. (f(XIN)=8MHz)
- 3) Set "00<sub>16</sub>" in the I<sup>2</sup>C status register so that transmission/reception mode is initialized.
- 4) Set a communication enable status by setting "08<sub>16</sub>" in the I<sup>2</sup>C control register 0.
- 5) When a START condition is received, an address comparison is performed.
- 6) •When all transmitted addresses are "0" (general call):
  - AD0 of the I<sup>2</sup>C status register is set to "1" and an interrupt request signal occurs.
  - When the transmitted addresses agree with the address set in 1):
    - ASS of the I<sup>2</sup>C status register is set to "1" and an interrupt request signal occurs.
    - In the cases other than the above AD0 and AAS of the I<sup>2</sup>C status register are set to "0" and no interrupt request signal occurs.
- 7) Set dummy data in the I<sup>2</sup>C data shift register.
- 8) After receiving 1 byte data, it returns an ACK automatically and an interrupt request signal occurs.
- 9) In the case of whether returning an ACK or not by the content of the received control data, set the WIT bit of I<sup>2</sup>C control register 1 to "1", and after writing dummy data to I<sup>2</sup>C data shift register, receives the control data.
- 10) After receiving 1 byte data, an interrupt request signal occurs, set the ACKBIT to "1" or "0" by reading the content of the data shift register. and then returns or does not return an ACK.
- 11) When receiving control data of more than 1 byte, repeat step 7) 8) or 7) 10).
- 12) When a STOP condition is detected, the communication ends.

## Usage precautions

### (1) Access to the registers of I<sup>2</sup>C-BUS interface circuit

The precaution of read/write to the control registers of I<sup>2</sup>C-BUS circuit is as follows.

- I<sup>2</sup>C data shift register (S0i : 0320<sub>16</sub>, 0330<sub>16</sub>)

Do not write the register during transfer. The transfer bit counter will be reset and makes data communication incorrect.

- I<sup>2</sup>C address register (S0Di : address 0322<sub>16</sub>, 0332<sub>16</sub>)

After the detection of a STOP condition, RBW is reset by H/W. Do not read/write the register at the time, because data may become undetermined. Fig.GC-22 shows the RBW bit H/W reset timing.

- I<sup>2</sup>C control register 0 (S1Di : address 0323<sub>16</sub>, 0333<sub>16</sub>).

After the detection of a START condition or the completion of 1 byte transfer, bit counter (bits BC0 - BC2) is reset by H/W. Do not read/write the register at the time, because data may become undetermined. Fig.GC-23, GC-24 show the bit counter H/W reset timing.

- I<sup>2</sup>C clock control register (S2i : address 0324<sub>16</sub>, 0334<sub>16</sub>)

Do not write to this register except ACKBIT during transfer. The I<sup>2</sup>C clock generator will be reset and makes transfer incorrect.

- I<sup>2</sup>C control register 1 (S3Di : address 0326<sub>16</sub>, 0336<sub>16</sub>)

Write I<sup>2</sup>C system clock selection bits when I<sup>2</sup>C-BUS interface enable bit (ES0) is in disable state. By reading the data reception completion interrupt enable bit (WIT), the internal WAIT flag will be read. Thus, do not use bit manipulation (read-modify-write instruction) to access the register.

- I<sup>2</sup>C status register (S1i : address 0328<sub>16</sub>, 0338<sub>16</sub>)

Do not use bit manipulation (read-modify-write instruction) to access the register because all bits of this register are changed by H/W. Do not read/write during the timing when communication mode setting bits MST and TRX are changed by H/W. Data may become undetermined. Fig.GC-22, GC-23, and GC-24 show the change timing of MST and TRX bits by H/W.

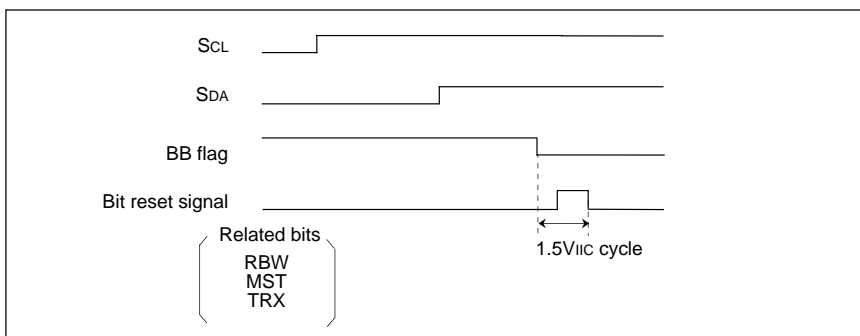

**Fig.GC-22 The timing of bit reset (The detection of STOP condition)**

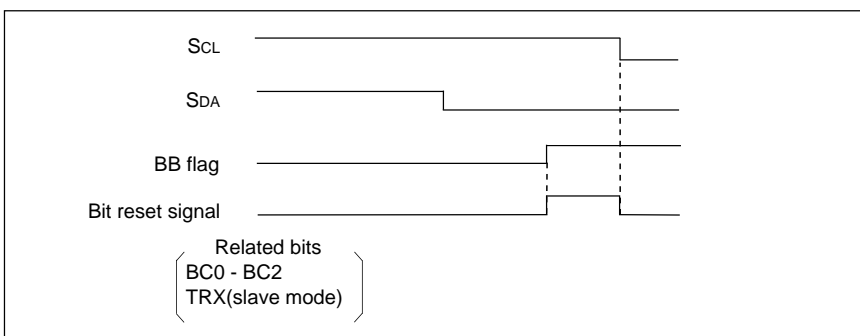

**Fig.GC-23 The timing of bit reset (The detection of START condition)**

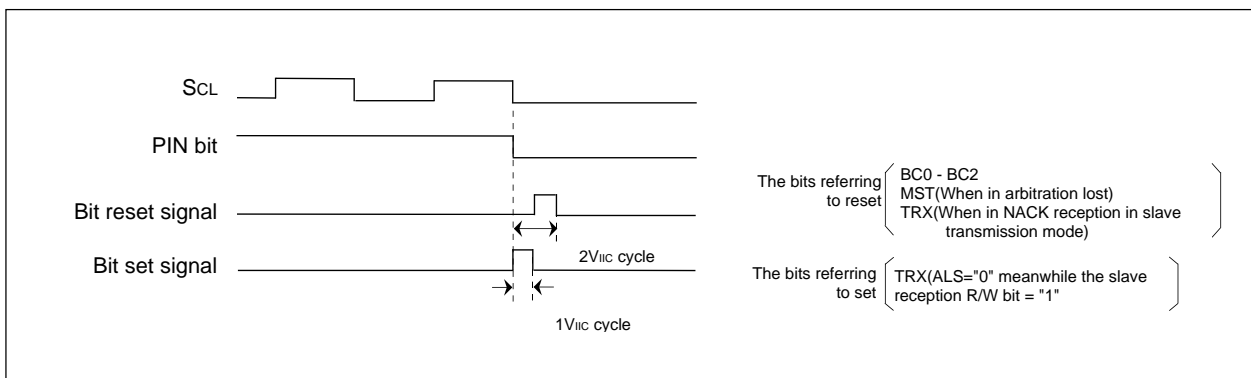

**Fig.GC-24 Bit set/reset timing ( at the completion of data transfer)**

## (2) Generation of RESTART condition

After 1 byte data transfer, a RESTART condition standby can be set up by writing "E016" to I<sup>2</sup>C status register and the SDA pin will be released. Wait in software until SDA become "H" stable and then owing to writing to I<sup>2</sup>C data shift register a START condition trigger will be generated. Fig.GC-25 shows the restart condition generation timing.

## (3) limitation of internal clock 0

The registers of I<sup>2</sup>C-BUS interface circuit can not be read from or written to if the internal clock up selected to sub clock (XCIN, XCOUT) by system clock selection bit (system clock control register 0, address 000616, CMO7 bit). Please select main clock (XIN, XOUT) in read/write.

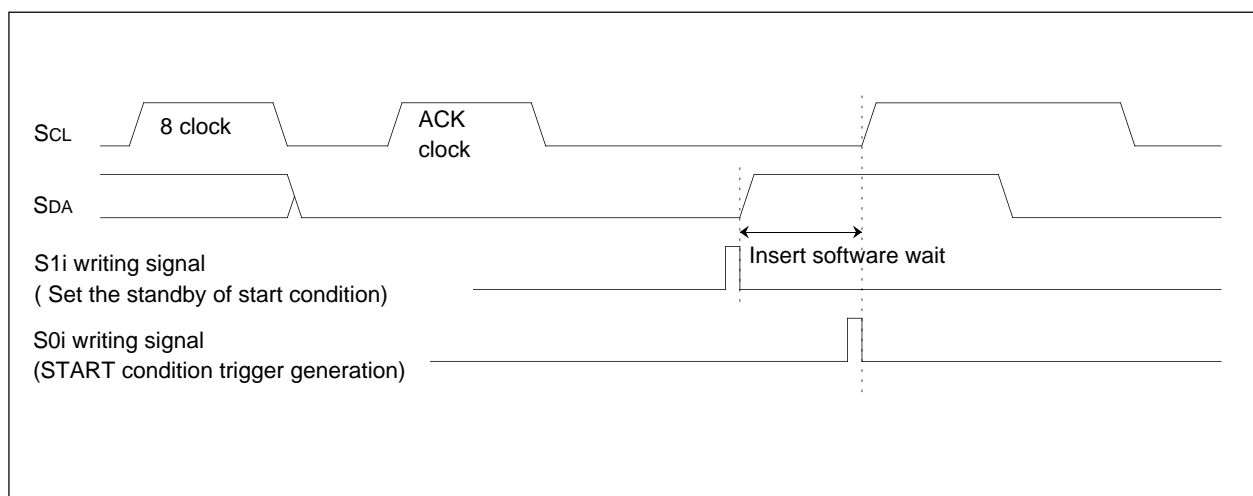

Fig.GC-25 The time of generation of RESTART condition

## PS2 Interface

PS2 interface is supported by 3 channels of serial transmission/reception circuit which is based on PS2 standard specifications.

There are two signal lines, used by PS2 interface : PS2 data(DAT) and PS2 clock(CLK).

The DAT and CLK signal lines are bidirection and should be connected to positive power supply via external pull-up resistors. These two pins are N-channel open drain output. While bus is released, the states of DAT and CLK is "High". Fig.GK-1 shows the system configuration.

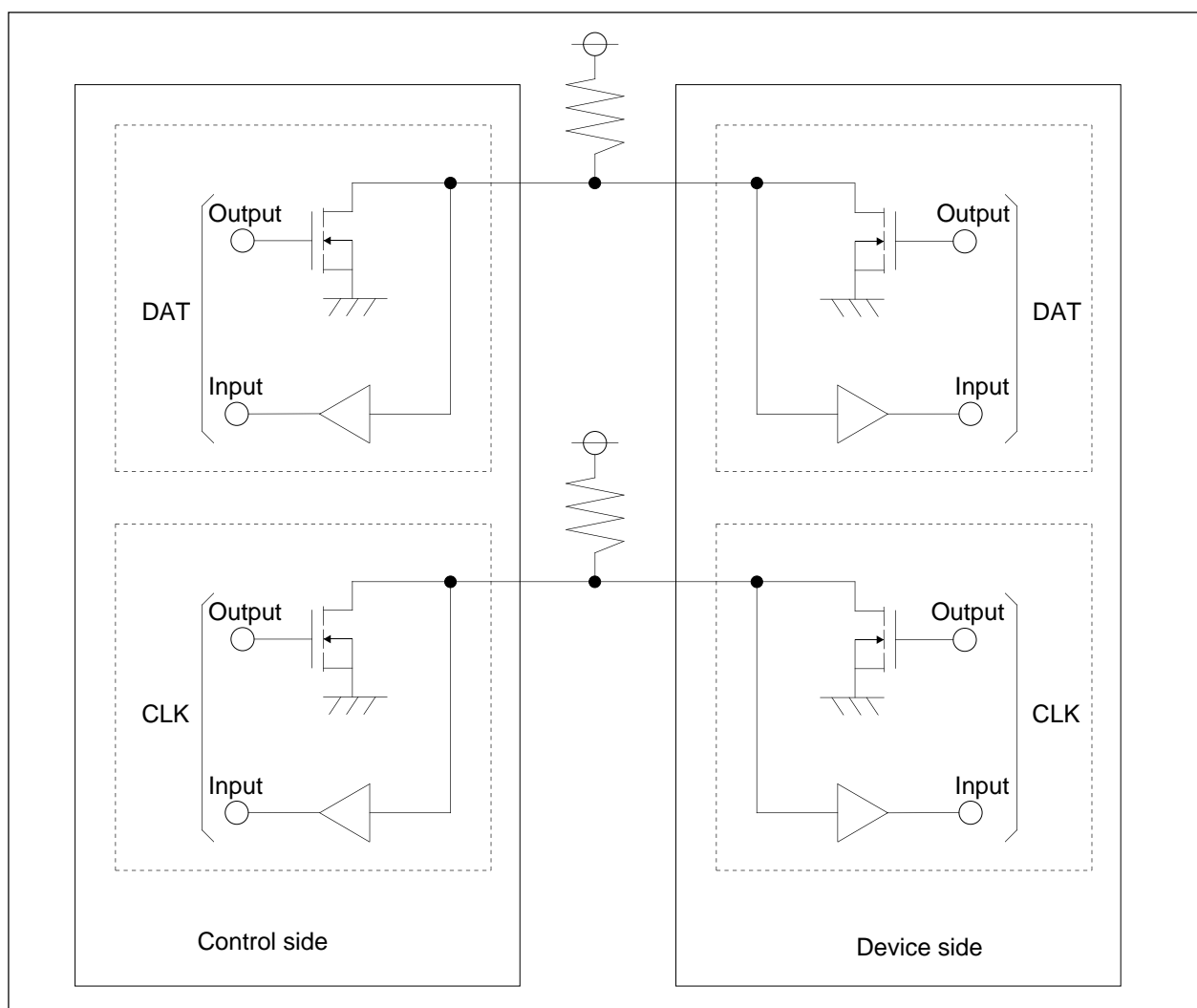
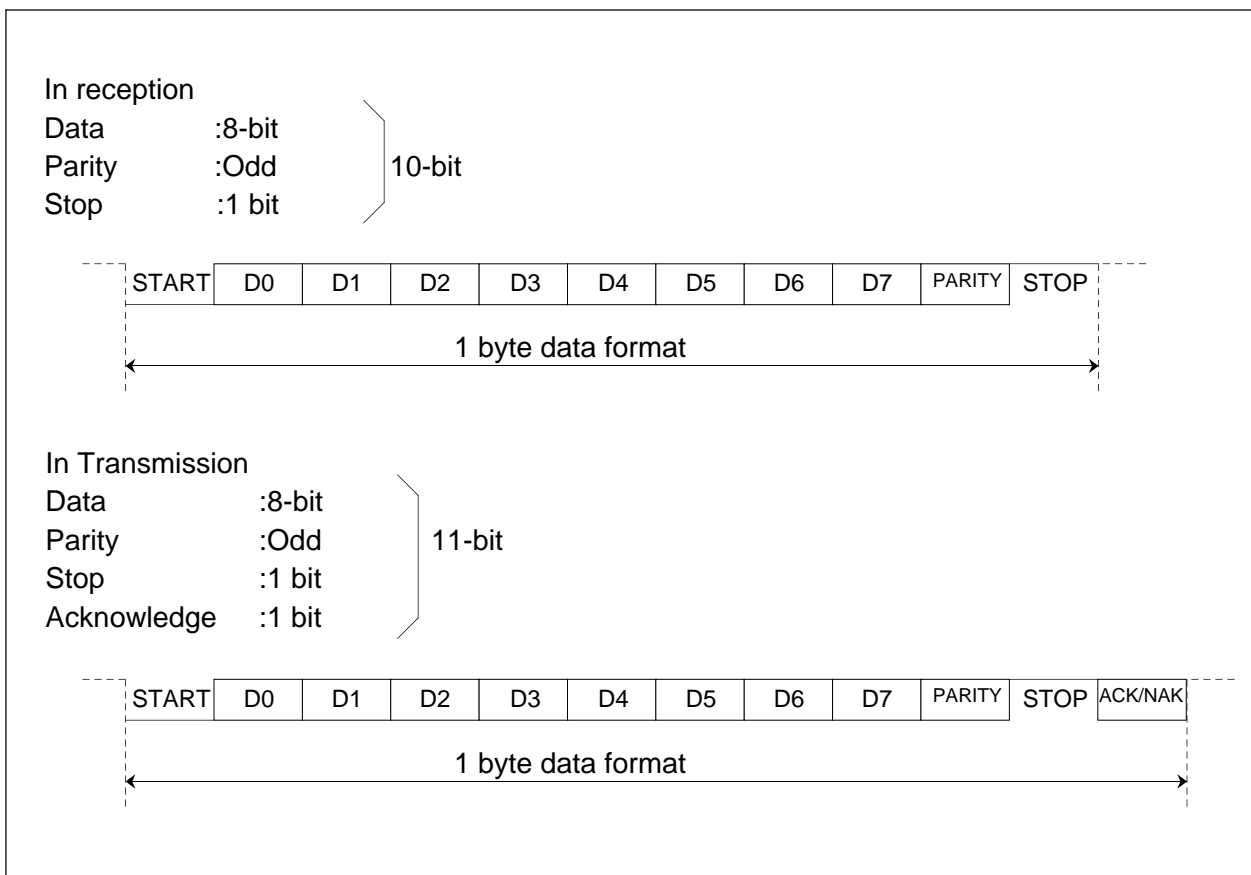

Fig.GK-1 System configuration

The PS2 interface performs 1 byte data transfer with the format shown in Fig.GK-2.  
Table GK-1 shows the communication specification.

**Table GK-1 Communication specification**

Item	Specification
Data transfer format	*Start bit : 1 bit *Data bit : 8 bits (LSB first) *Parity bit : 1 bit (Odd) *Stop bit : 1 bit *Acknowledge : 1 bit (Transmission only)
Transfer clock	*Using the clock, which is synchronized with the sampling clock of PS2 clock (CLK)
Reception start condition	*The following conditions should be met for reception start 1) Setting reception enable bit to "1" 2) The detection of "L" on both PS2 clock (CLK) and PS2 data (DAT) lines
Transmission start condition	*The following conditions should be met for transmission start 1) Setting transmission data to PS2i shift register 2) Setting transmission enable bit to "1"
Transfer abort	*The following conditions should be met for transfer abort 1) Setting transfer interruption bit to "1" 2) The transfer completion flag becomes "1"
Interrupt request generation timing	*In reception: At the completion of stop bit reception *In transmission: At the completion of ACK bit reception. *In transfer interruption: At the completion of transfer interruption
Error detection	*Parity error (In reception) It occurs when there is a parity error in data reception *Framing error (In reception) It occurs when the detection of stop bit of reception data fails. *Abnormal acknowledge reception (In transmission) It occurs when NAK is received from a device side after the data transmission
Selection function	*Sampling clock selection Selecting the clock which samples the PS2 clock (CLK) and PS2 data (DAT)



**Fig.GK-2 1 byte data format**



Fig.GK-3 shows the PS2 interface overall block diagram.  
 Fig.GK-4 shows the transmission/reception block diagram.

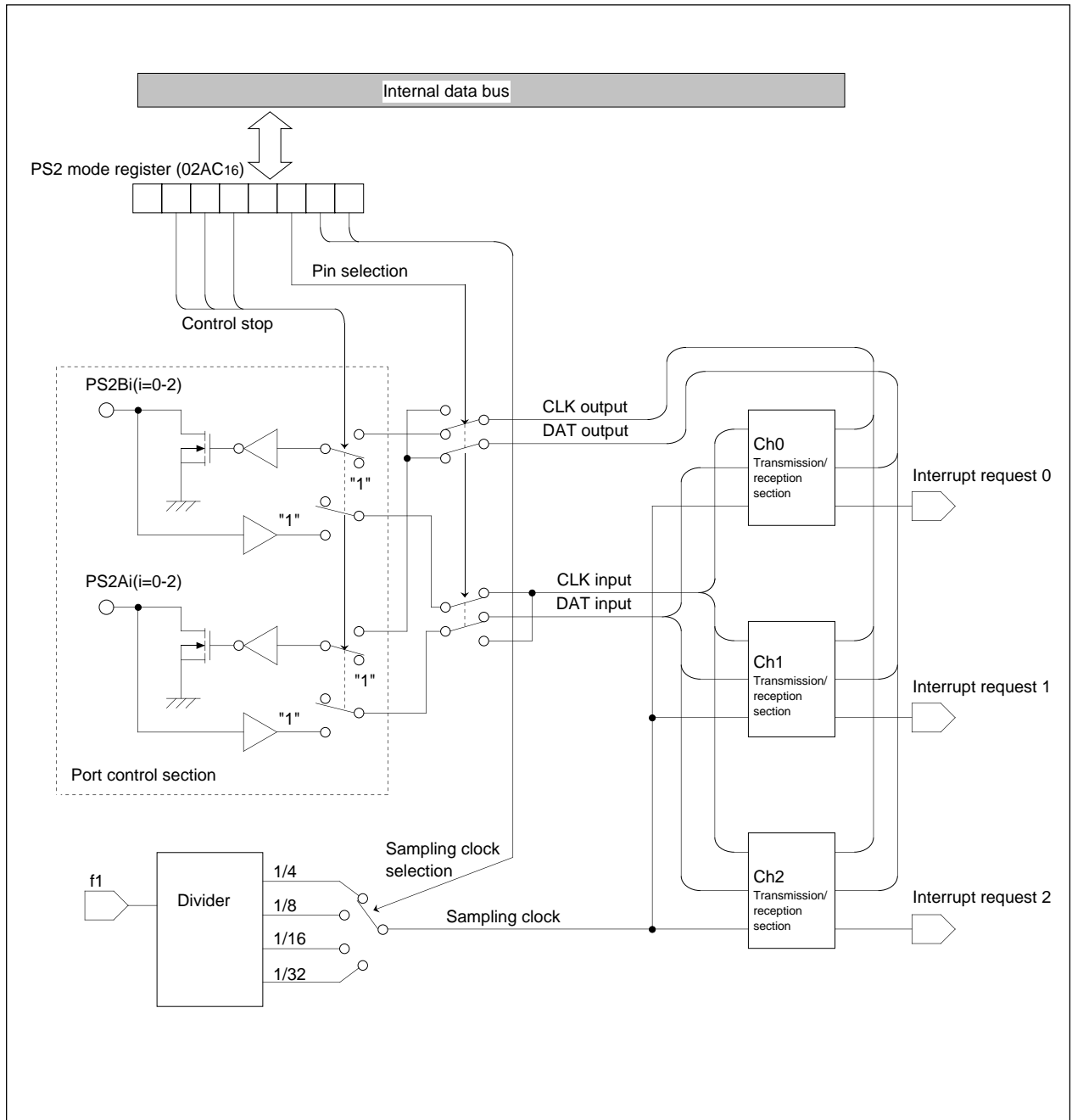

**Fig.GK-3 PS2 interface block diagram**

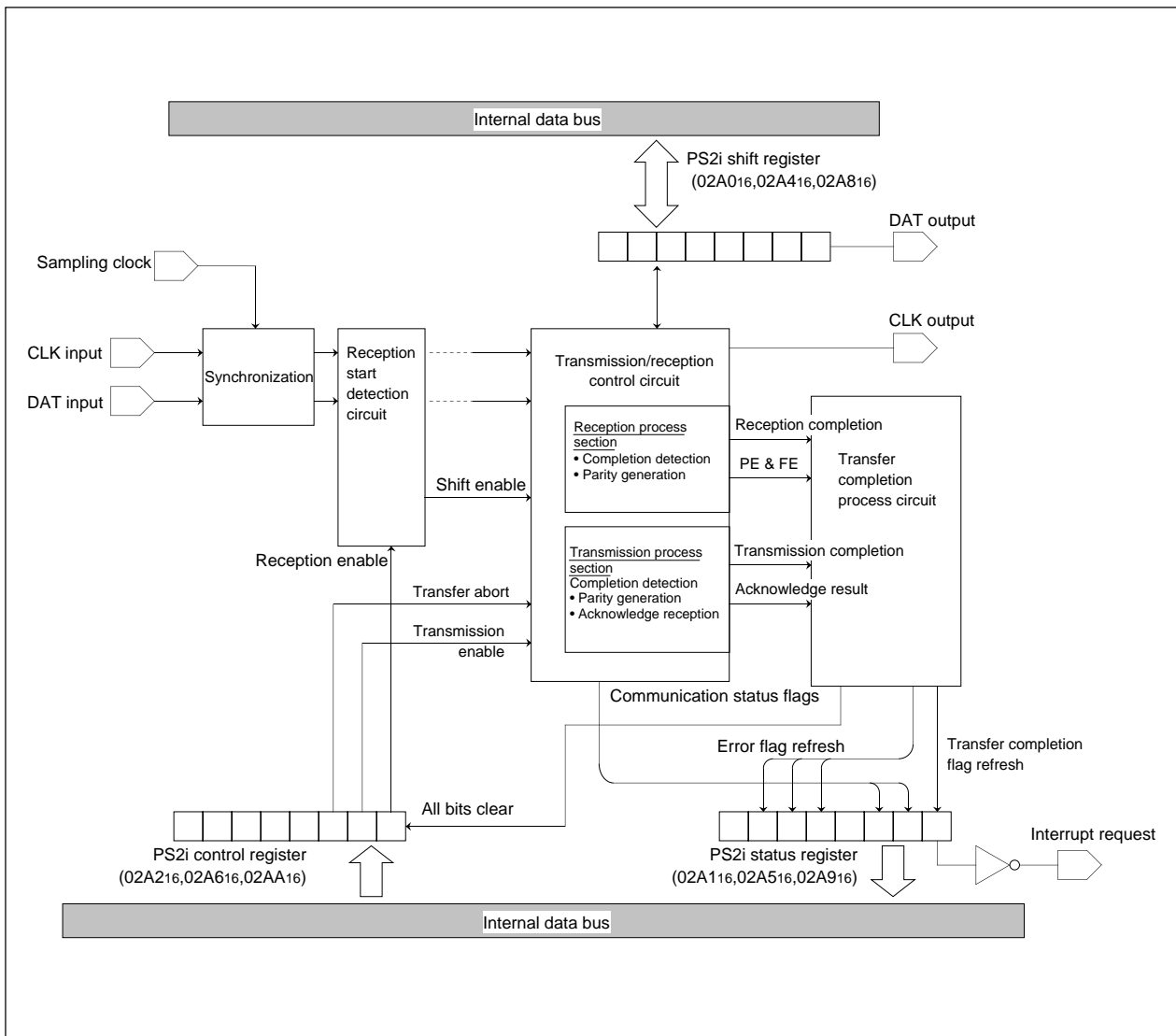

Fig.GK-4 Transmission/reception section block diagram (One channel)

(1) Register description

- PS2i shift register
- Transmission/reception data

(1) Data reception

The reception data are stored.

(2) Data transmission

By writing the transmitted data to the register, data transmission is ready to start. PS2 data (DAT) will become "L" automatically (transmission start).

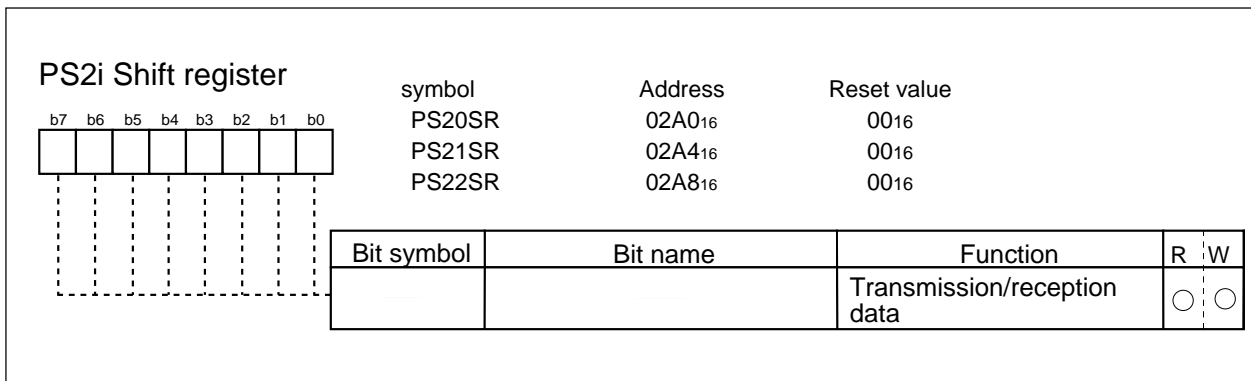

Fig.GK-5 PS2i shift register

● PS2i Control register

• Reception enable bit (REN)

The data reception is allowed when this bit is set to "1". The PS2 clock (CLK) will become to "H" (reception enable status) automatically.

This bit will be cleared to "0" automatically after the completion of data reception and PS2 clock (CLK) will become "L" (reception disable status) .

If this bit is needed wants to be cleared after setting it to "1" but before the transfer completion flag is set, set reception enable bit = "0", transfer abort request bit = "0" and process the transfer abort simultaneously.

• Transmission enable bit (TEN)

After writing transmission data to the PS2i shift register, setting the bit to "1" makes data transmission enabled and PS2 clock (CLK) will become "H" automatically (transmission enable status).

This bit will be cleared to "0" automatically after the completion of data transmission and PS2 clock (CLK) will become "L" (transmission disable status).

If this bit is needed to be cleared after setting it to "1" but before the transfer completion flag is set, set reception enable bit = "0", transfer abort request bit = "0" and process the transfer abort simultaneously.

• Transfer abort request bit (RSTOP)

This bit is used to abort the data transfer procession.

At the completion of transfer abort procession, the transfer completion flag and transfer abort flag of PS2i status register are set to "1", the bit is cleared to "0" automatically and PS2 clock (CLK) will become "L" ( reception disable status).

After "L" is output to the PS2 clock (CLK), do not execute the following transmission/reception before the device recognizes the transfer abort request.

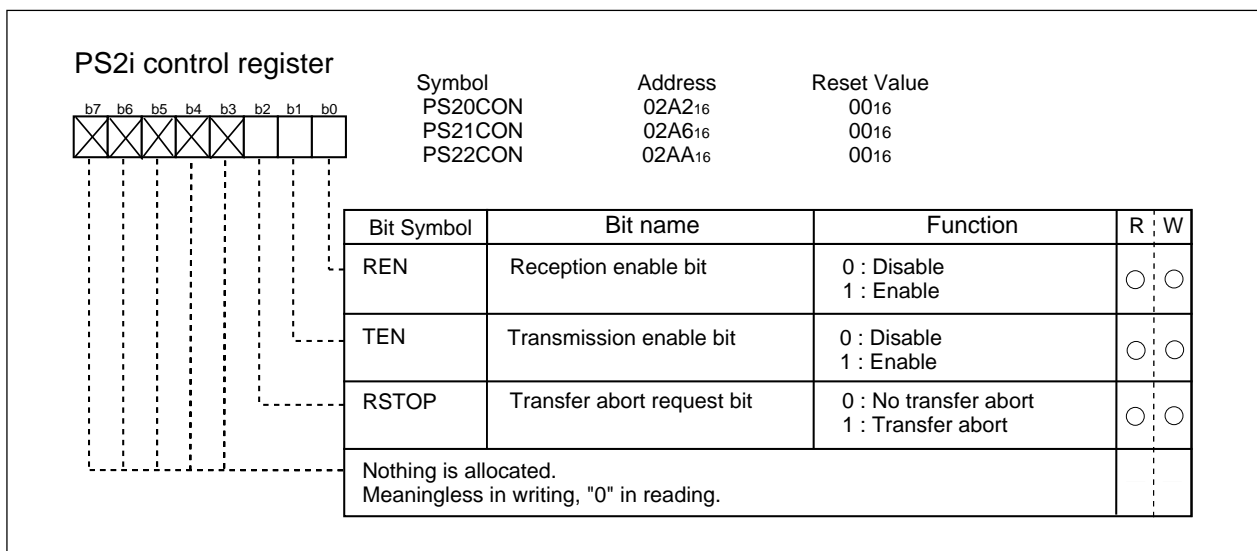

Fig.GK-6 PS2i control register

**●PS2i status register****• Transfer completion flag (TI)**

The flag is set to "1" at the completion of transmission/reception and the completion of transfer abort.

The flag is cleared at read out from PS2i shift register or when the reception enable bit is changed from "0" to "1".

**• Receiving flag (RF)**

The flag is set to "1" during the data reception.

The flag is cleared automatically after the data reception or after the transfer abort.

**• Reception abort incognizable flag (CD)**

The flag is set in the case that device side can not recognize the abort even if the reception abort is requested. (The flag is set in the period between the completion of data bit 6 reception and the completion of stop bit reception.) The flag is cleared automatically after the completion of data reception or after the completion of transfer abort.

\* Note that during the period when the flag is set, the device side can not recognize the reception abort request even if the transfer abort is executed. Thus the data that the transfer abort is requested will not be resent from device side.

**• Transfer status flag (TS)**

The flag is set to "1" at the completion of data reception.

The flag is cleared at read out from PS2i shift register or when the reception enable bit is changed from "0" to "1".

**• Parity error flag (PE)**

This bit is set to "1" when parity error occurs in received data.

The flag is cleared at read out from PS2i shift register or when the reception enable bit is changed from "0" to "1".

**• Framing error / NACK reception flag (FE)**

At the completion of reception: The flag is set when the detection of stop bit of reception data fails.

At the completion of transmission: The flag is set when NAK is received from the device side.

The flag is cleared at read out from PS2i shift register, the reception enable bit or the transmission bit is changed from "0" to "1".

**• Transfer abort completion flag (CC)**

This bit is set to "1" when transfer abort procession is completed.

The flag is cleared at read out from PS2i shift register, or when the reception enable bit or the transmission bit is changed from "0" to "1".

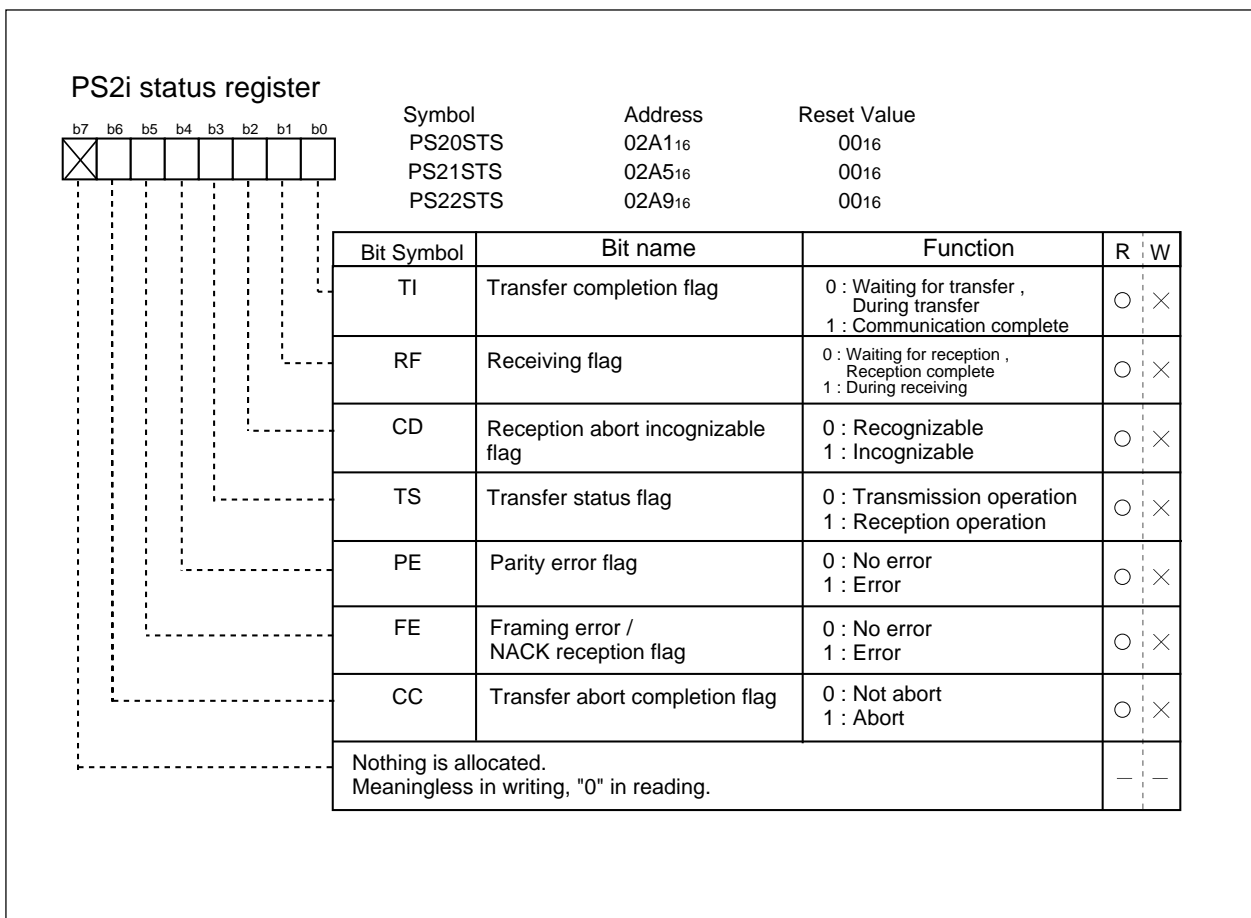

Fig.GK-7 PS2i status register

- PS2 mode register

- Sampling clock selection bits (SCK0,1)

These two bits select clock frequency for sampling PS2 clock (CLK) and PS2 data (DAT).

The relation between main clock (XIN) and sampling cycle is shown in table below.

XIN \ Setting value	1/4	1/8	1/16	1/32
8MHz	0.5 $\mu$	1.0 $\mu$	2.0 $\mu$	4.0 $\mu$
5MHz	0.8 $\mu$	1.6 $\mu$	3.2 $\mu$	6.4 $\mu$

\*Sampling clock, which samples each line periodically, is used for avoiding the reflection from each line. The sampling clock will be delayed by internal circuit around 1 cycle. Thus, set the sampling clock as fast as possible.

- Pin selection bit (PSEL)

This bit is for selecting PS2 clock (CLK) or PS2 data (DAT) to connect to PS2Bi (i=0 to 2). PS2Bi are external interrupt input pins. The bit setting definition is shown in table below.

Pin selection bit	PS2Bi (i= 0 to 2)
"0"	PS2 clock (CLK)
"1"	PS2 data (DAT)

- PS2 interface enable bit (PSEN)

The PS2Ai (i= 0 to 2) and PS2Bi (i= 0 to 2) will be disconnected to hardware PS2 control section and become GPIO port when the bit is "0".

The PS2Ai and PS2Bi will be connected to hardware PS2 control section when this bit is "1".

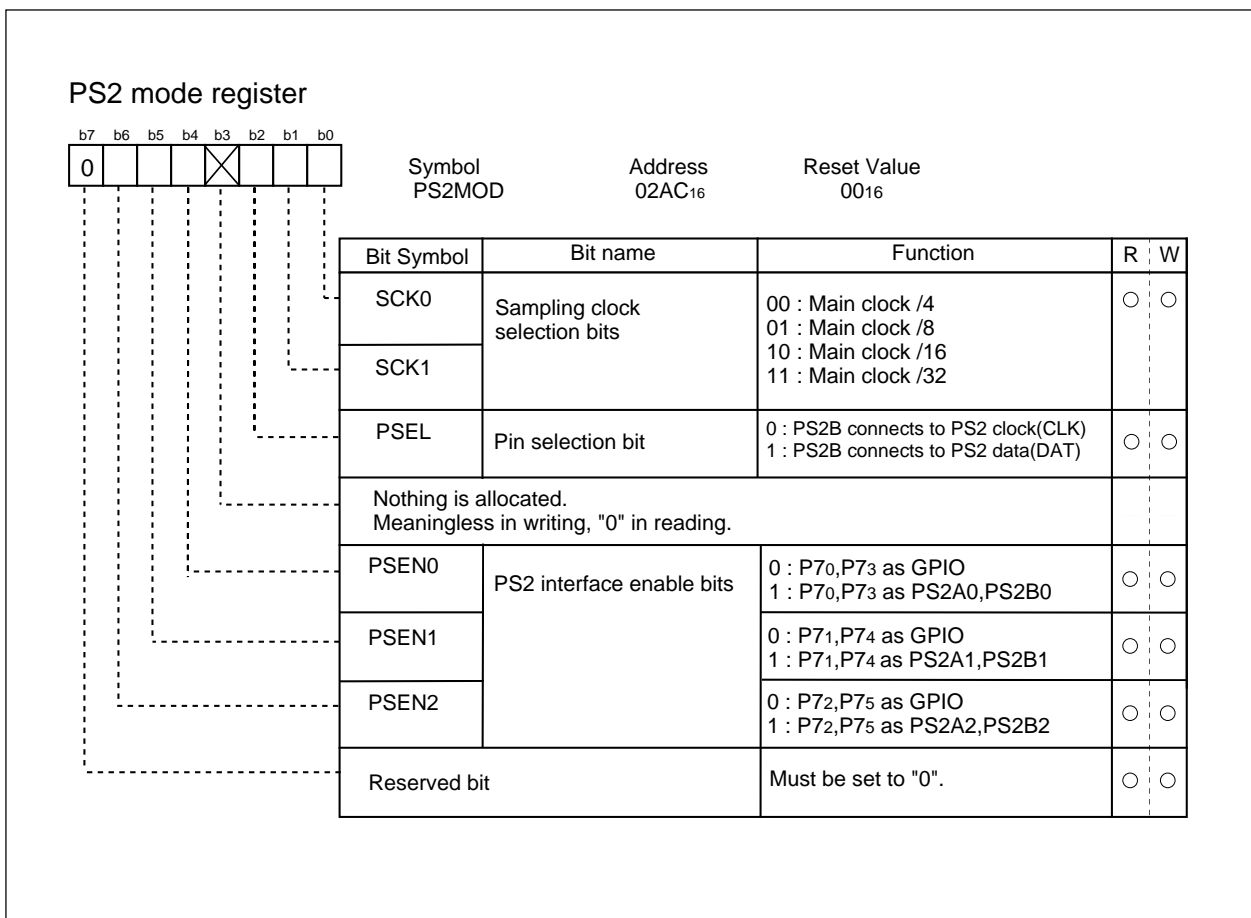

Fig.GK-8 PS2 mode register



## (2) Operation description

### ● Basic setting

The following items should be set for PS2 mode register (address 02AC<sub>16</sub>) set when PS2 interface is used.

- PS2 interface enable bit

Set the PS2 interface enable bits (bit4 to 6 of PS2 mode register) to “1” to enable the PS2 channels to be used. At this time PS2 clock goes “Low” (Receiving disable).

- Sampling clock selection bit

Sampling clock cycle (1/4,1/8,1/16,1/32 of main clock) is selected by setting sampling clock bit (bits 0,1).

- External interrupt function support pin (PS2B) selection

This bit is used to select PS2 clock (CLK) or PS2 data (DAT) for the external interrupt function support pin (PS2B).

● Reception operation

Fig.GK-9 shows the reception operation timing.

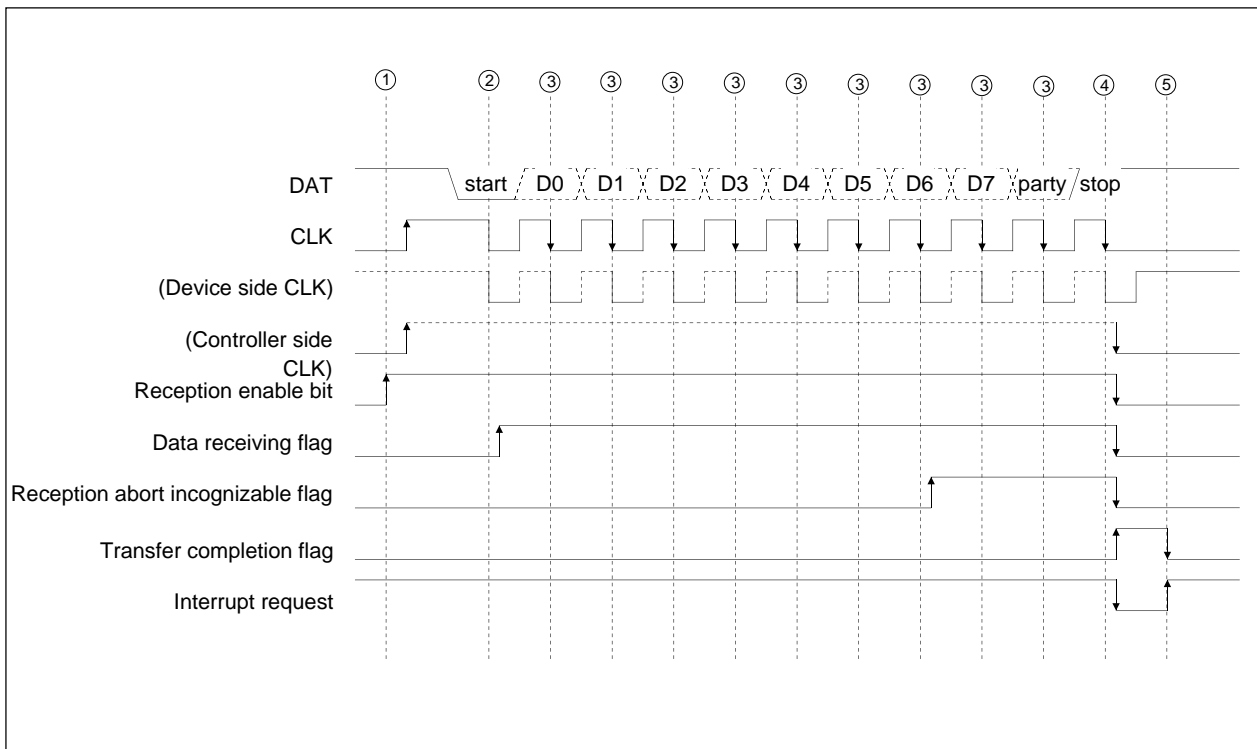

**Fig.GK-9 Reception operation timing**

(1) Reception enable

The reception operation is enabled by writing 0116 (reception enable bit = "1") to PS2i control register (address : 02A216, 02A616, 02AA16). The PS2 clock (CLK) will become "H".

(2) Reception start

The reception operation starts when both PS2 clock (CLK) and PS2 data (DAT) are detected with "L".

(3) Data reception (The reception of data and parity bits)

The content PS2 data (DAT) is read into PS2i shift register (address : 02A016, 02A416, 02A816) sequentially by the falling edge of PS2 clock (CLK). The data transfer sequence is data bit (D0 -D7) then parity bit.

(4) Reception completion (Stop bit Reception completion)

By detecting the falling edge of PS2 clock (CLK), the transfer completion flag (bit 0 of PS2i status register) is set to "1" after the update of error flag (bit 4 - 6 of PS2i status register) and the reception enable bit (bit 0 of PS2i control register) is cleared to "0". The PS2 clock (CLK) becomes "L" (reception disable status) and interrupt request occurs.

(5) Data read out

Read out data from PS2i shift register (address : 02A016,02A416,02A816). At this time , the error flags (Bit4 to 6) of and transfer completion flag (bit 0) of PS2i status register (address: 02A116, 02A516, 02A916) will be cleared to "0".

● Transmission operation

Fig.GK-10 shows the transmission operation timing.

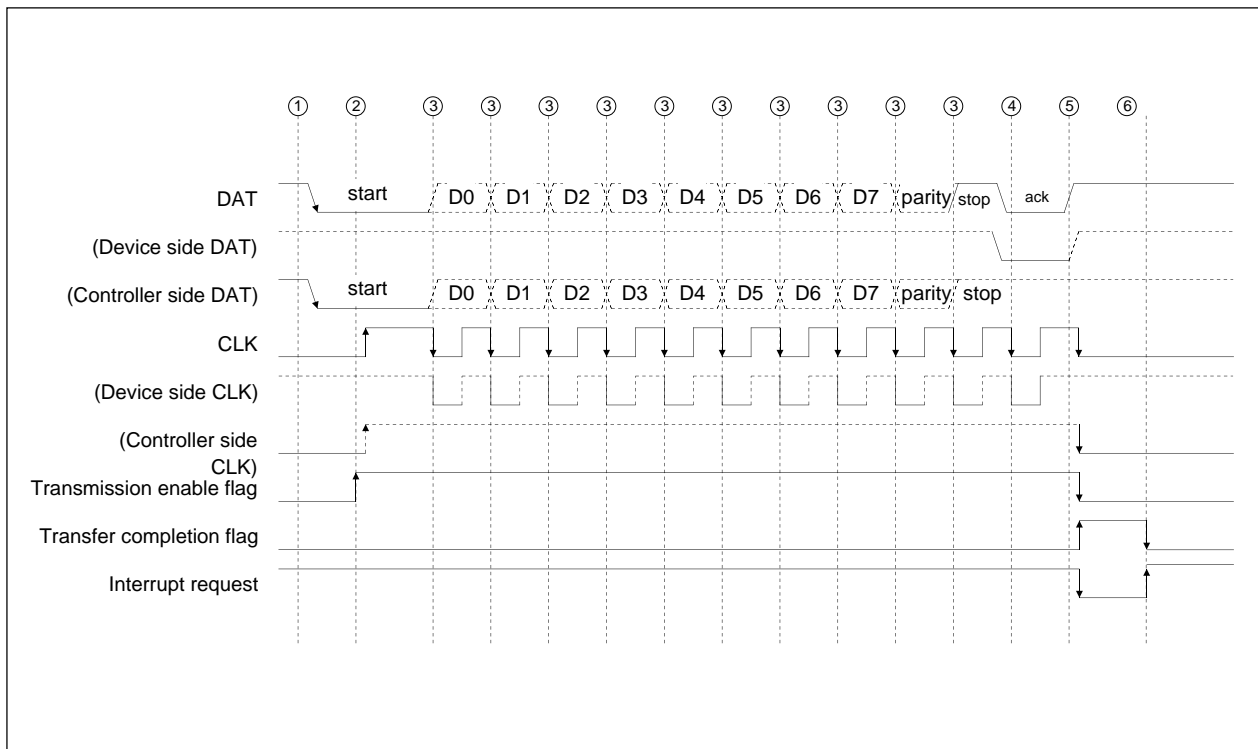

Fig.GK-10 Transmission operation timing

(1) Data writing

Write transmission data to PS2i shift register (address : 02A0<sub>16</sub>, 02A4<sub>16</sub>, 02A8<sub>16</sub>). At this time, PS2 data will become "L" (transmission start).

(2) Transmission enable

Set 02<sub>16</sub> (Transmission enable bit = "1") to PS2i control register (address : 02A2<sub>16</sub>, 02A6<sub>16</sub>, 02AA<sub>16</sub>) for enabling transmission operation. At this time, PS2 clock (CLK) will become "H".

(3) Data transmission (The transmission of data, parity and stop bits)

The content of PS2i shift register (address : 02A0<sub>16</sub>, 02A4<sub>16</sub>, 02A8<sub>16</sub>) will be output to the PS2 data (DAT) sequentially by the falling edge of PS2 clock (CLK). The sequence of data transfer is data bits (D0 to D7), Parity bit, and stop bit.

(4) Acknowledge reception

The content of acknowledge bit will be read by the falling edge of PS2 clock (CLK).

(5) Communication completion

The communication operation is completed by detecting "H" on both PS2 clock (CLK) and PS2 data (DAT). After the update of error flag (bit 4 - 6 of PS2i status register), the transfer completion flag (bit 0 of PS2i status register) is set to "1" and the reception enable bit (bit 0 of PS2i control register) is cleared to "0". At this time, PS2 clock (CLK) becomes "L" (reception disable status) and the interrupt request occurs.

(6) Status clear

Read out the data from PS2i shift register (address : 02A0<sub>16</sub>, 02A4<sub>16</sub>, 02A8<sub>16</sub>). At this time, the error flags (bits 4 to 6) and transfer completion flag (Bit0) of PS2i status register (address : 02A1<sub>16</sub>, 02A5<sub>16</sub>, 02A9<sub>16</sub>) will be cleared to "0".

● Transfer abort operation

Fig.GK-11 shows the transfer abort operation timing.

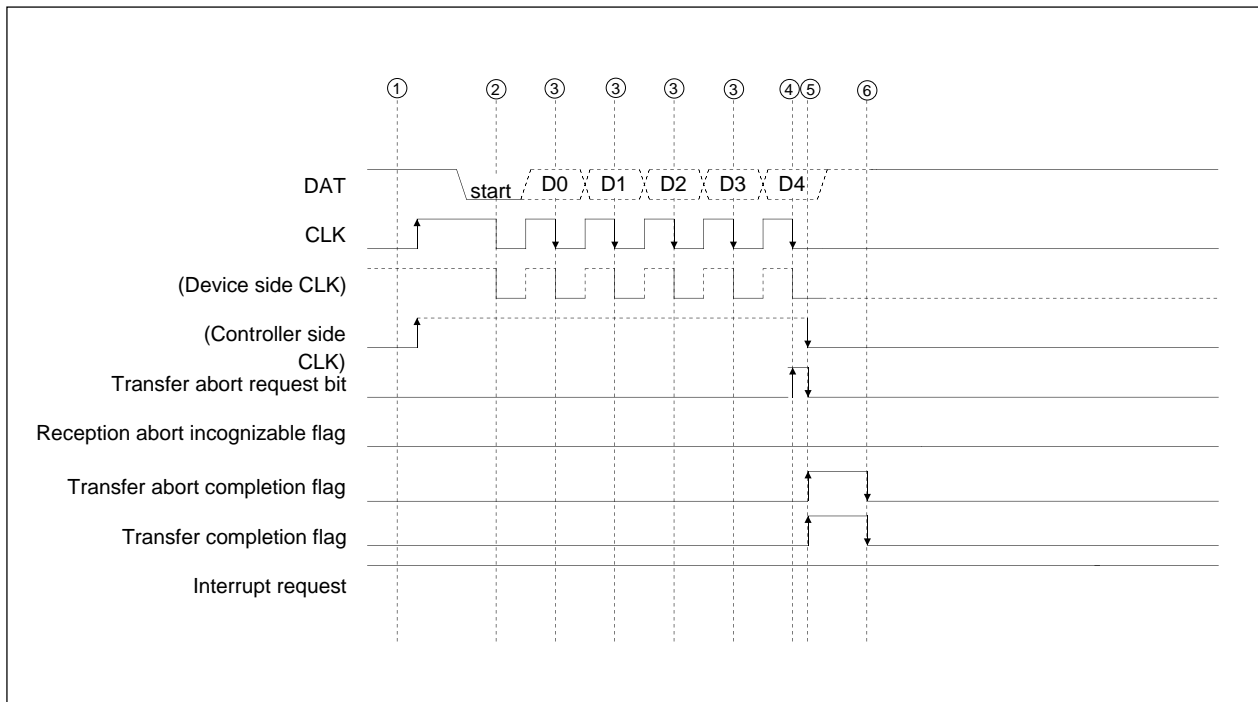

**Fig.GK-11 Transfer abort operation timing ( reception)**

(1) - (3) Data reception operation

(4) Transfer abort request

Set 04<sub>16</sub> (transfer abort request bit = "1") to PS2i control register (address : 02A2<sub>16</sub>, 02A6<sub>16</sub>, 02AA<sub>16</sub>).

(5) Transfer abort completion

The transfer abort completion flag (bit 6) and transfer completion flag (bit 0) of PS2i status register (address : 02A1<sub>16</sub>, 02A5<sub>16</sub>, 02A9<sub>16</sub>) are set to "1", transfer abort request bit (bit 2) of PS2i control register (address : 02A2<sub>16</sub>, 02A6<sub>16</sub>, 02AA<sub>16</sub>) is cleared to "0". At this time, PS2 clock (CLK) becomes "L" (reception disable status) and interrupt request occurs.

(6) Status clear

By a pseudo read of PS2i shift register (address : 02A0<sub>16</sub>, 02A4<sub>16</sub>, 02A8<sub>16</sub>), the transfer abort completion flag (bit 6) and transfer completion flag (bit 0) of PS2i status register (address : 02A1<sub>16</sub>, 02A5<sub>16</sub>, 02A9<sub>16</sub>) are cleared to "0".

Note: Do not execute the following transmission/reception during the period between the "L" output from PS2 clock (CLK) and the transfer abort request recognition of the device.

## Programmable I/O Ports

There are 129 programmable I/O ports: P0 to P16 (excluding P85). Each port can be set independently for input or output using the direction register. A pull-up resistance for each block of 4 ports can be set. The N channel open drain ports P60 to P63, P70 to P77, P80 to P84, P130 to P137 and P85 (input only port) do not build internal pull-up resistance.

Fig.UA-1 to UA-6 show the configurations of programmable I/O ports.

Each pin functions as a programmable I/O port and as the I/O for the built-in peripheral devices.

To use the pins as the inputs for the built-in peripheral devices, set the direction register of each pin to input mode. When the pins are used as the outputs for the built-in peripheral devices (other than the D-A converter), they function as outputs regardless of the contents of the direction registers. When pins are used as the outputs for the D-A converter, do not set the direction registers to output mode. See the descriptions of the respective functions for how to set up the built-in peripheral devices.

### (1) Direction registers

Fig.UA-7 shows the configurations of direction registers.

These registers are used to choose the direction of the programmable I/O ports. Each bit in these registers corresponds one for one to each I/O pin.

Note: There is no direction register bit for P85.

### (2) Port registers

Fig.UA-8 shows the configurations of port registers.

These registers are used to write and read data for input and output to and from exterior. A port register consists of a port latch to hold output data and a circuit to read the status of a pin. Each bit in port registers corresponds one for one to each I/O pin.

### (3) Pull-up control registers

Fig.UA-9 and UA-10 shows the configurations of pull-up control registers.

The pull-up control register can be set to apply a pull-up resistance to each block of 4 ports. When ports are set to have a pull-up resistance, the pull-up resistance is connected only when the direction register is set for input.

### (4) Port control register

Fig.UA-11 shows the configurations of port control register 0, 1. Fig.UA-12 shows the configurations of port control register 2, 3. The bit 0 of port control register 0 is used to read port P1 as follows:

0 : When port P1 is input port, port input level is read.

When port P1 is output port, the contents of port P1 register is read.

1 : The contents of port P1 register is read always. (neither input port nor output port)

The P0, P1, P40 to P46, P11 and P14 output type, CMOS or N channel open drain, are set by bit 0 to 6 of port control register 1 and bit 0 to 2 of port control register 3.

0 : CMOS output

1 : N channel open drain output

Exception: P42 output type is N channel open drain if either bit 4 of port control register 1 or bit 2 of port control register 3 is set to "1".

Bit 7 of port control register1 functions as below

0 : P40/P43 output is cleared by software only

1 : P40/P43 output is cleared by software or when output buffer 0 is read by host side.

The driving ability of N channel output transistors for P140 to P143 can be selected by bit 6 of port control register 2 controls as below:

0 : Driving ability of N channel open drain output transistor is LOW

1 : Driving ability of N channel open drain output transistor is HIGH

### (5) Port P4/P7 input register

Fig.UA-13 shows the configurations of P4 and P7 input register.

By reading the registers, the input level of the corresponding pins can be known regardless the input/output mode. These two registers can be read regardless port direction setting. And the ports level will be read out.

Port4 : Bit 0 to bit6's level will be read out. And bit7 is always "0".

Port7 : Bit 0 to bit5's level will be read out. And bit6,7 is always "0".

### (6) Port function selection register 0,1

Fig.UA-14 shows the configurations of port function selection register 0,1. The port functions of UART0 to UART2 output, TimerA0 to TimerA2 output, TimerB3,B4 input or external interrupt INT6 to INT12 input can be switched by setting these two registers. And by setting bit6,7 of port function selection register 1, the same frequency clock with  $f(XIN)$  can be output from P66 and P67.

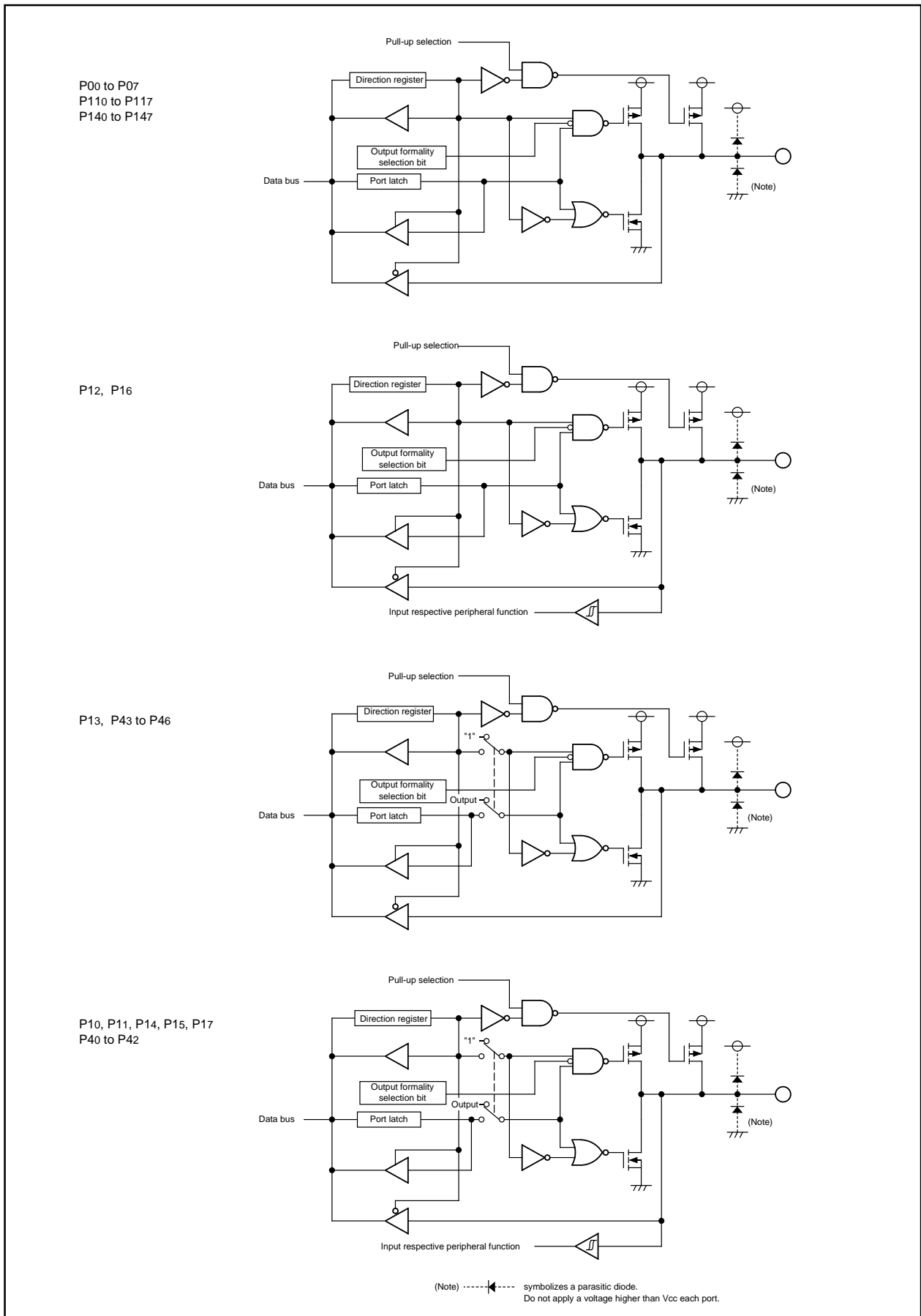

Fig.UA-1 Programmable I/O ports (1)

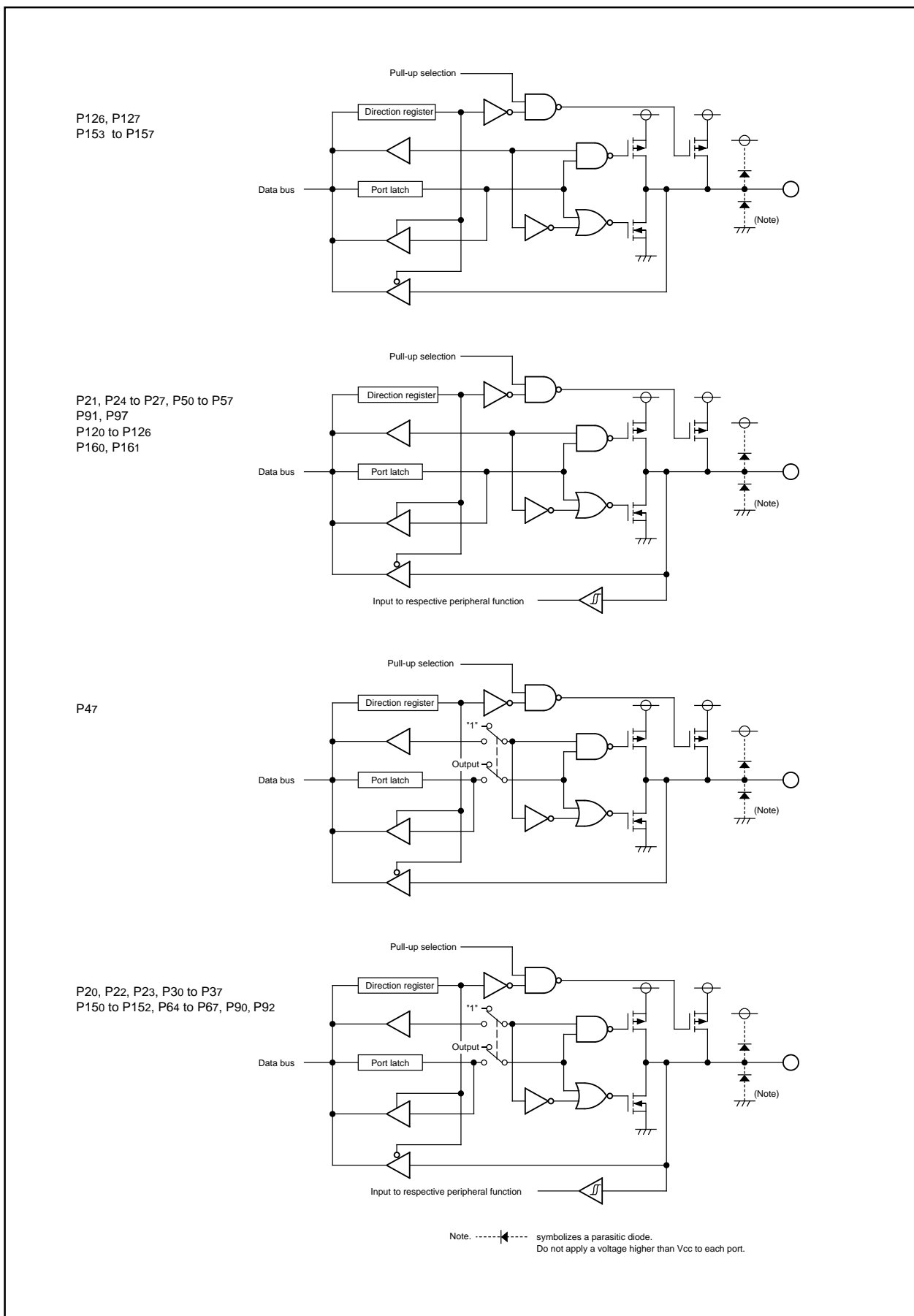
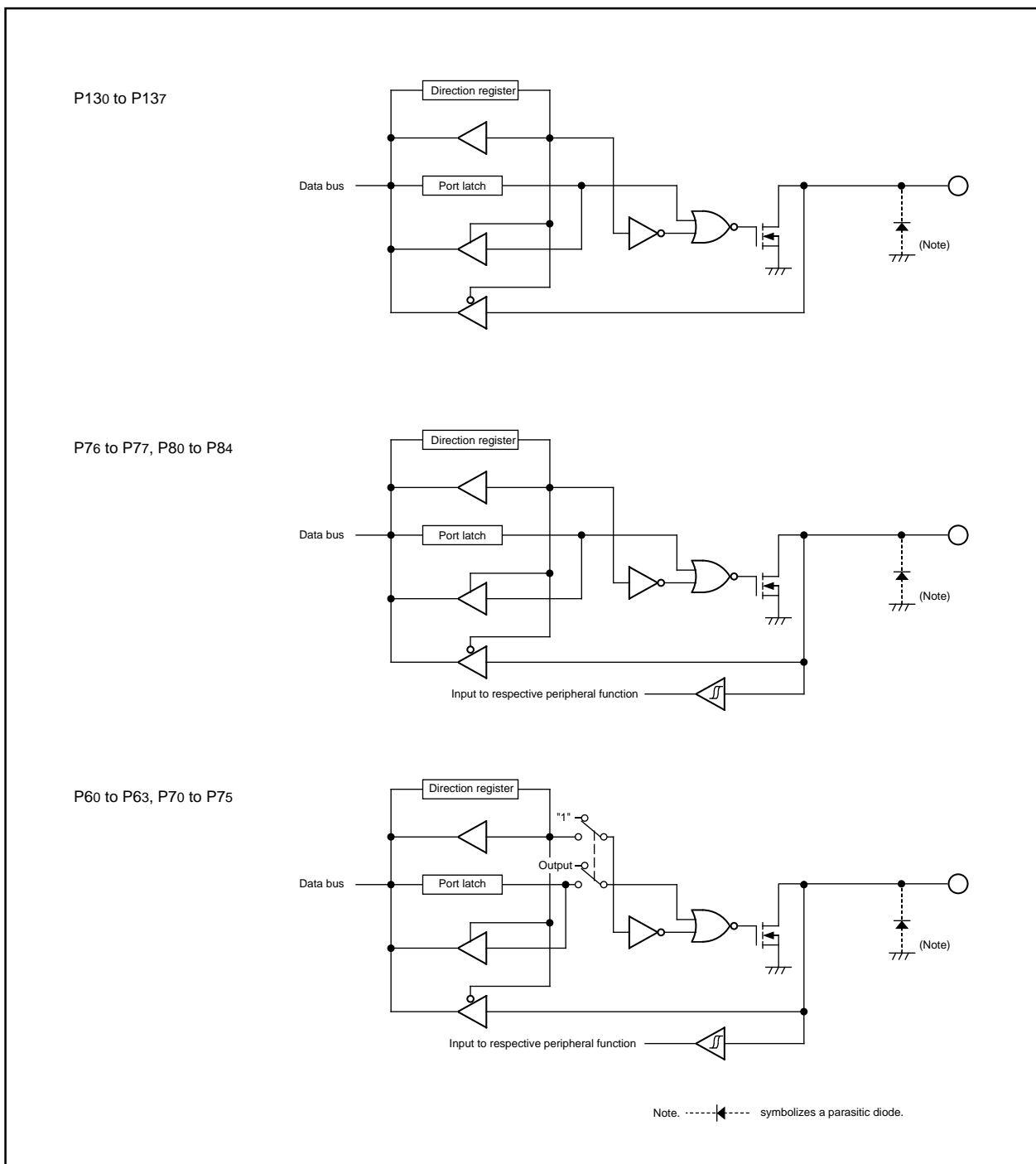

Fig.UA-2 Programmable I/O ports (2)





**Fig.UA-3 Programmable I/O ports (3)**

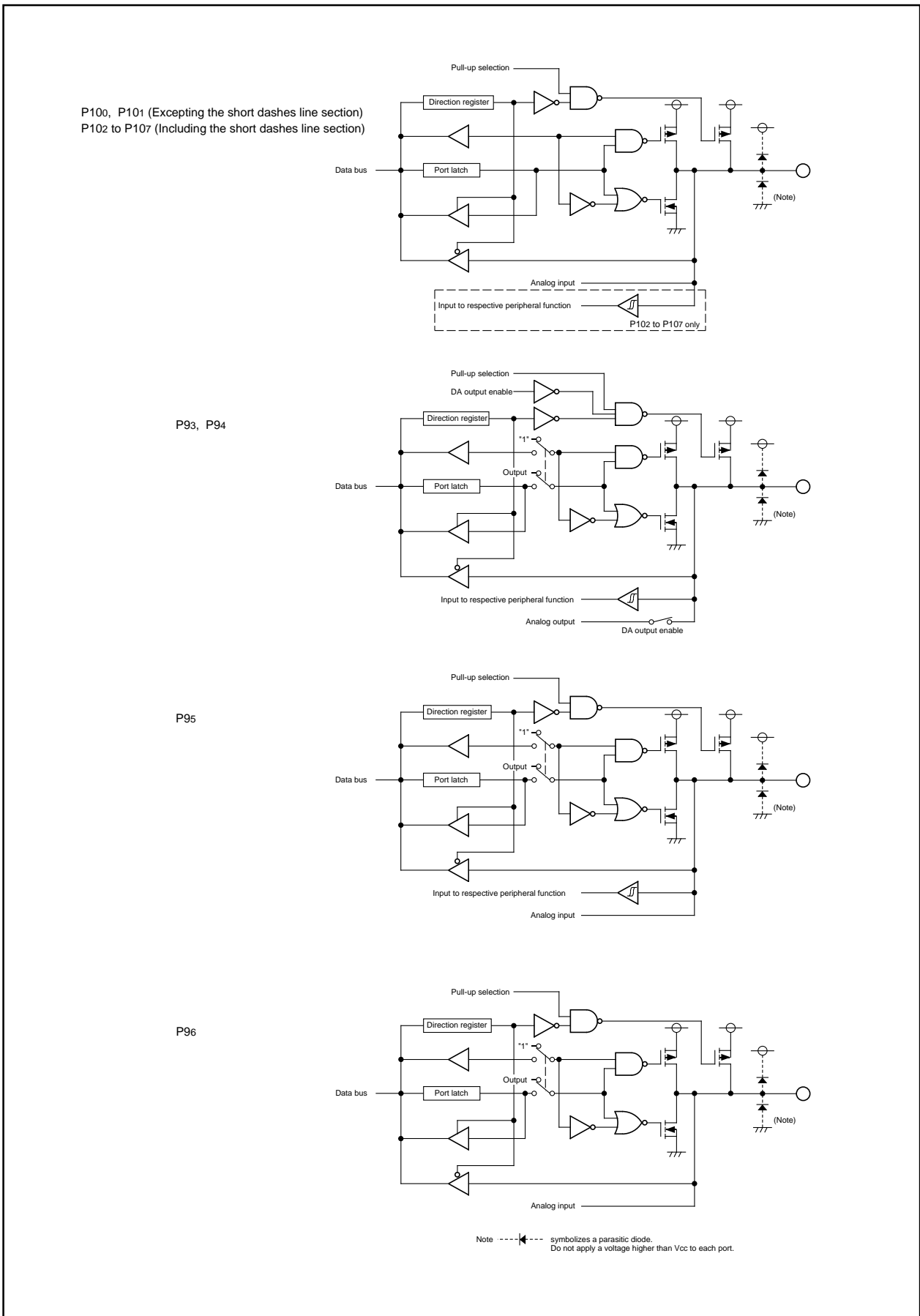

Fig.UA-4 Programmable I/O ports (4)

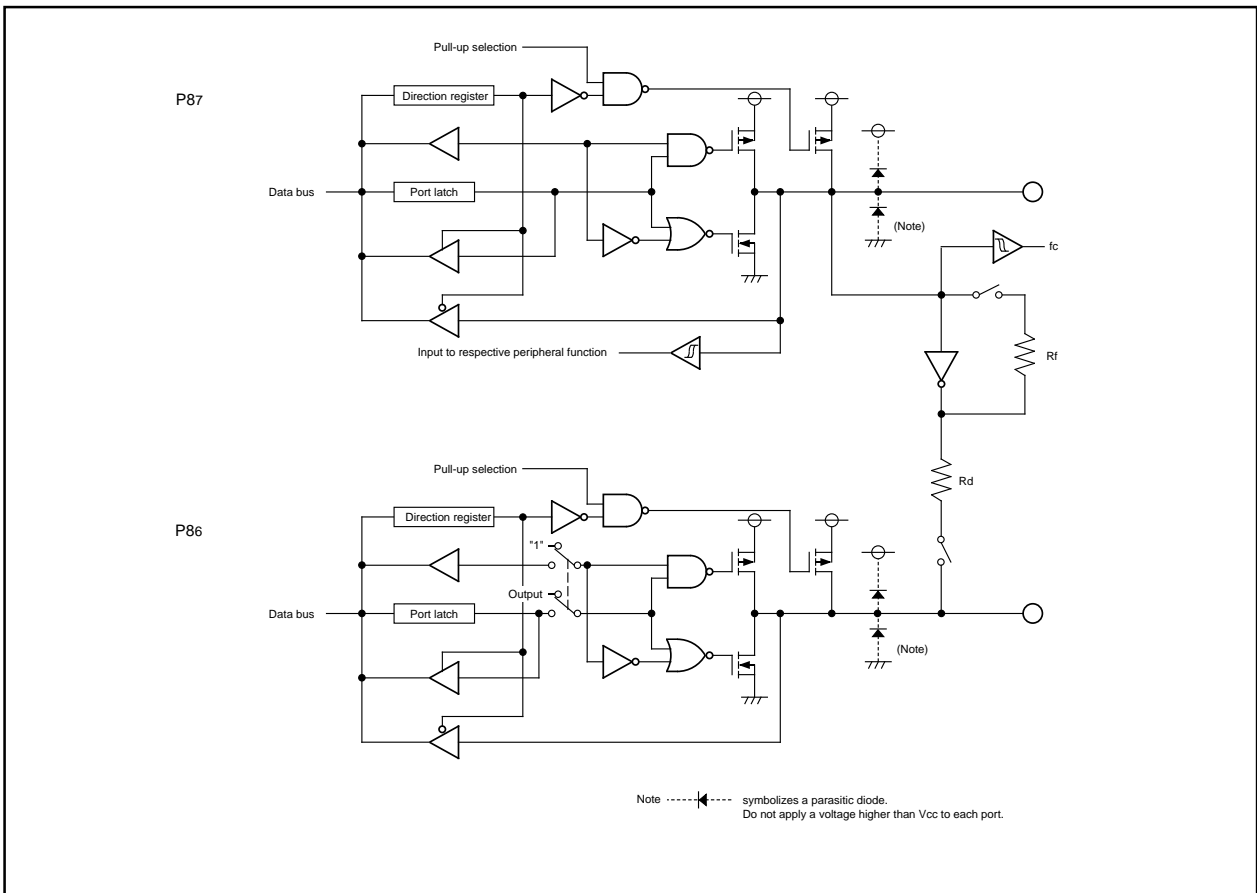

Fig.UA-5 Programmable I/O ports (5)

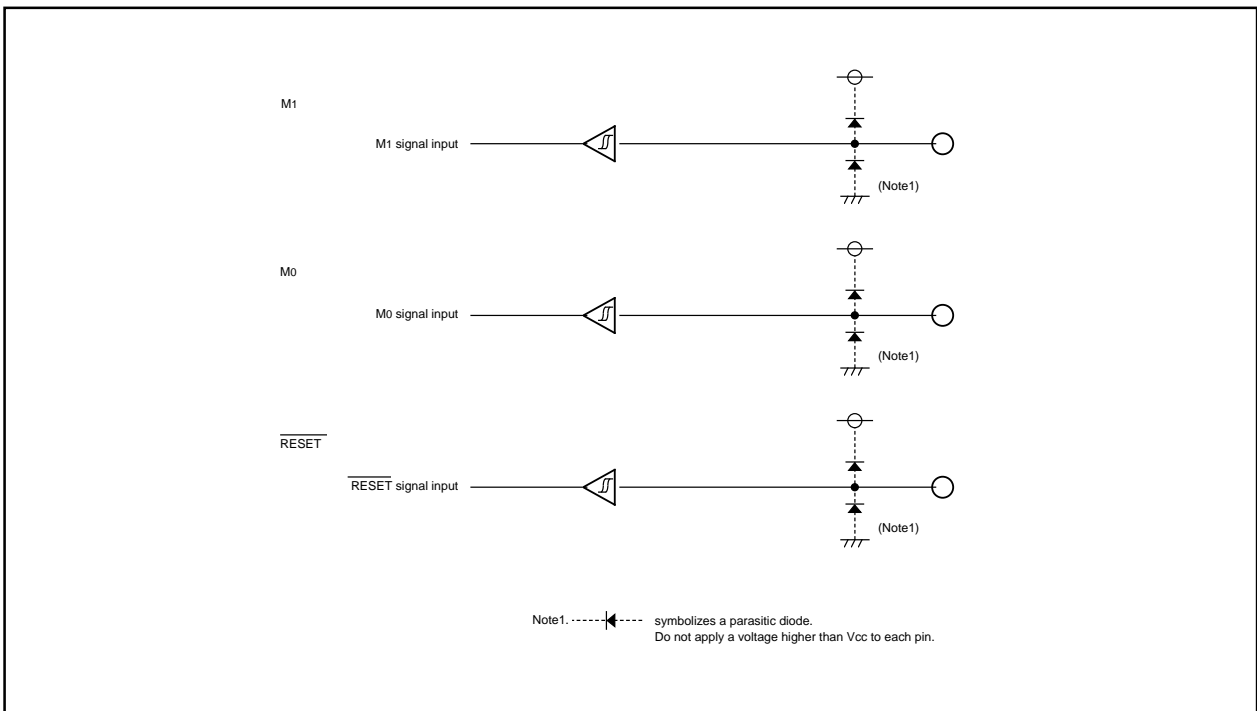
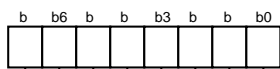

Fig.UA-6 I/O pins

Port Pi direction register (Note1)

symbol	Address	When reset
PDi(i=0-15, except 8)	03E2 <sub>16</sub> ,03E3 <sub>16</sub> ,03E6 <sub>16</sub> ,03E7 <sub>16</sub> ,03EA <sub>16</sub> 03EB <sub>16</sub> ,03EE <sub>16</sub> ,03EF <sub>16</sub> ,03F3 <sub>16</sub> ,03F6 <sub>16</sub> 02E2 <sub>16</sub> ,02E3 <sub>16</sub> ,02E6 <sub>16</sub> ,02E7 <sub>16</sub> ,02EA <sub>16</sub>	00 <sub>16</sub>



Bit symbol	Bit name	Function	R	W
PDi_0	Port P <sub>i0</sub> direction register	0 : Input mode (Function as an input port) 1 : Output mode (Function as an output port)  (i=0-15, except 8)	○	○
PDi_1	Port P <sub>i1</sub> direction register		○	○
PDi_2	Port P <sub>i2</sub> direction register		○	○
PDi_3	Port P <sub>i3</sub> direction register		○	○
PDi_4	Port P <sub>i4</sub> direction register		○	○
PDi_5	Port P <sub>i5</sub> direction register		○	○
PDi_6	Port P <sub>i6</sub> direction register		○	○
PDi_7	Port P <sub>i7</sub> direction register		○	○

Note Set bit 2 of protect register(address 000A<sub>16</sub>) to "1" before rewriting to the port P9 direction register.

Port P8 direction register

Symbol	Address	When reset
PD8	03F2 <sub>16</sub>	00X0000 <sub>2</sub>

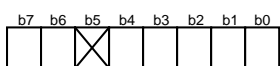

Bit symbol	Bit name	Function	R	W
PD8_0	Port P8 <sub>0</sub> direction register	0 : Input mode (Function as an input port) 1 : Output mode (Function as an output port)	○	○
PD8_1	Port P8 <sub>1</sub> direction register		○	○
PD8_2	Port P8 <sub>2</sub> direction register		○	○
PD8_3	Port P8 <sub>3</sub> direction register		○	○
PD8_4	Port P8 <sub>4</sub> direction register		○	○
Nothing is assigned. In an attempt to write to this bit, write "0". The value, if read, turns out to be indeterminate.			—	—
PD8_6	Port P8 <sub>6</sub> direction register	0 : Input mode (Function as an input port) 1 : Output mode (Function as an output port)	○	○
PD8_7	Port P8 <sub>7</sub> direction register		○	○

Port P16 direction register

Symbol	Address	When reset
PD16	02EB <sub>16</sub>	XXXXXX00 <sub>2</sub>

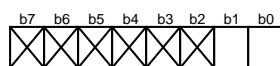

Bit symbol	Bit name	Function	R	W
PD16_0	Port P16 <sub>0</sub> direction register	0 : Input mode (Function as an input port) 1 : Output mode (Function as an output port)	○	○
PD16_1	Port P16 <sub>1</sub> direction register		○	○
Nothing is assigned. In an attempt to write to this bit, write "0". The value, if read, turns out to be indeterminate.			—	—

Fig.UA-7 Direction register

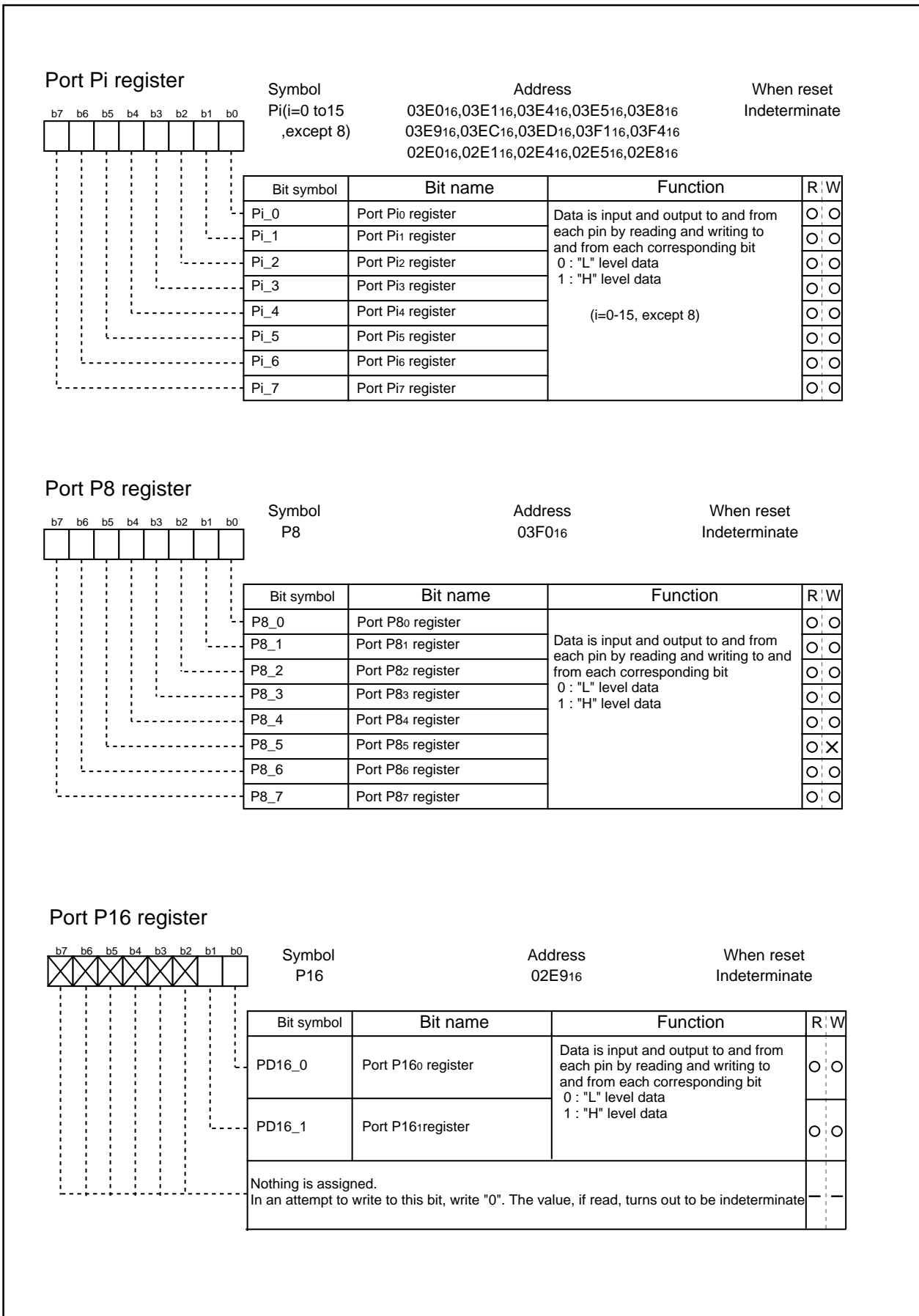

Fig.UA-8 Port register

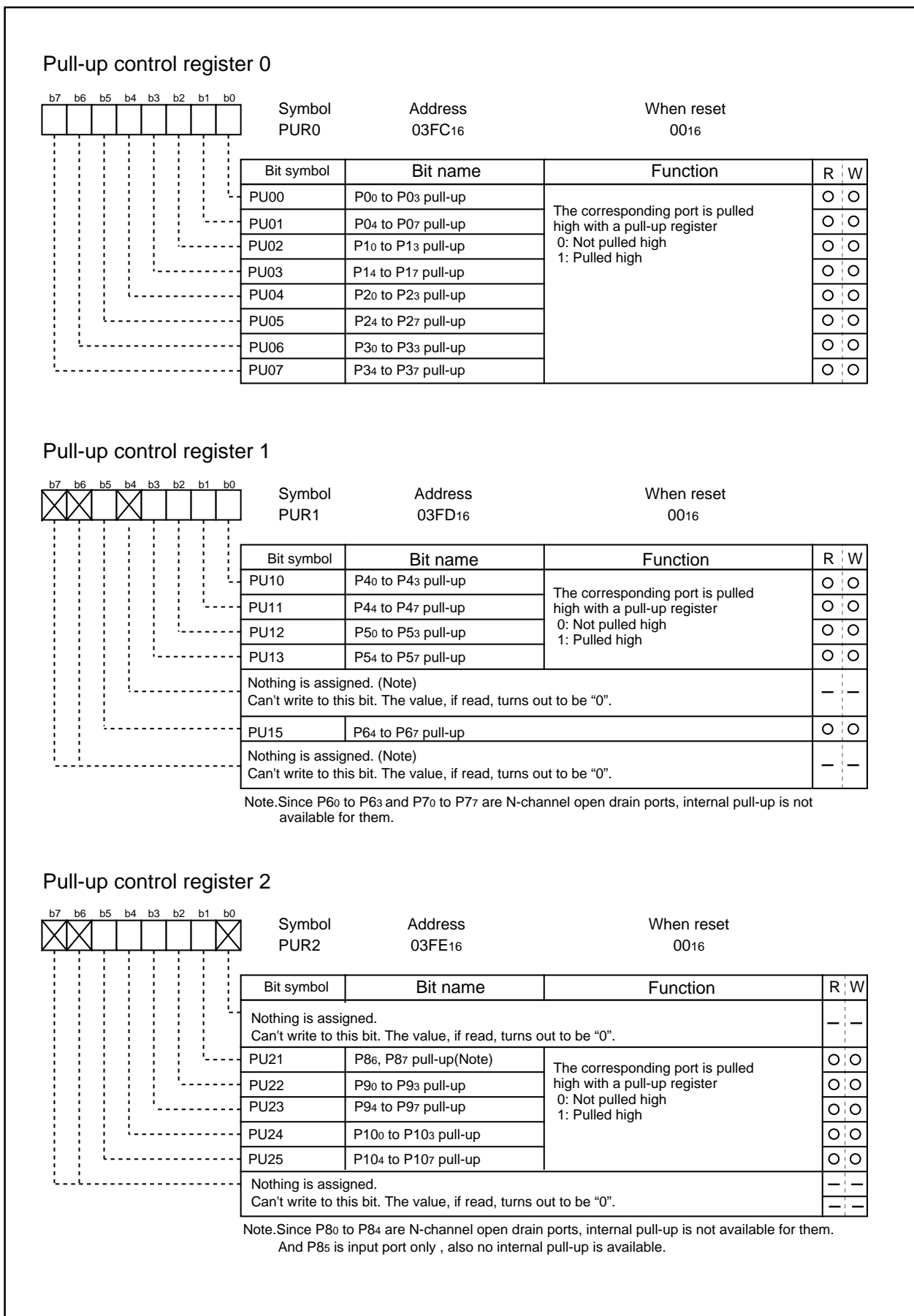

Fig.UA-9 Pull-up control resiter(1)

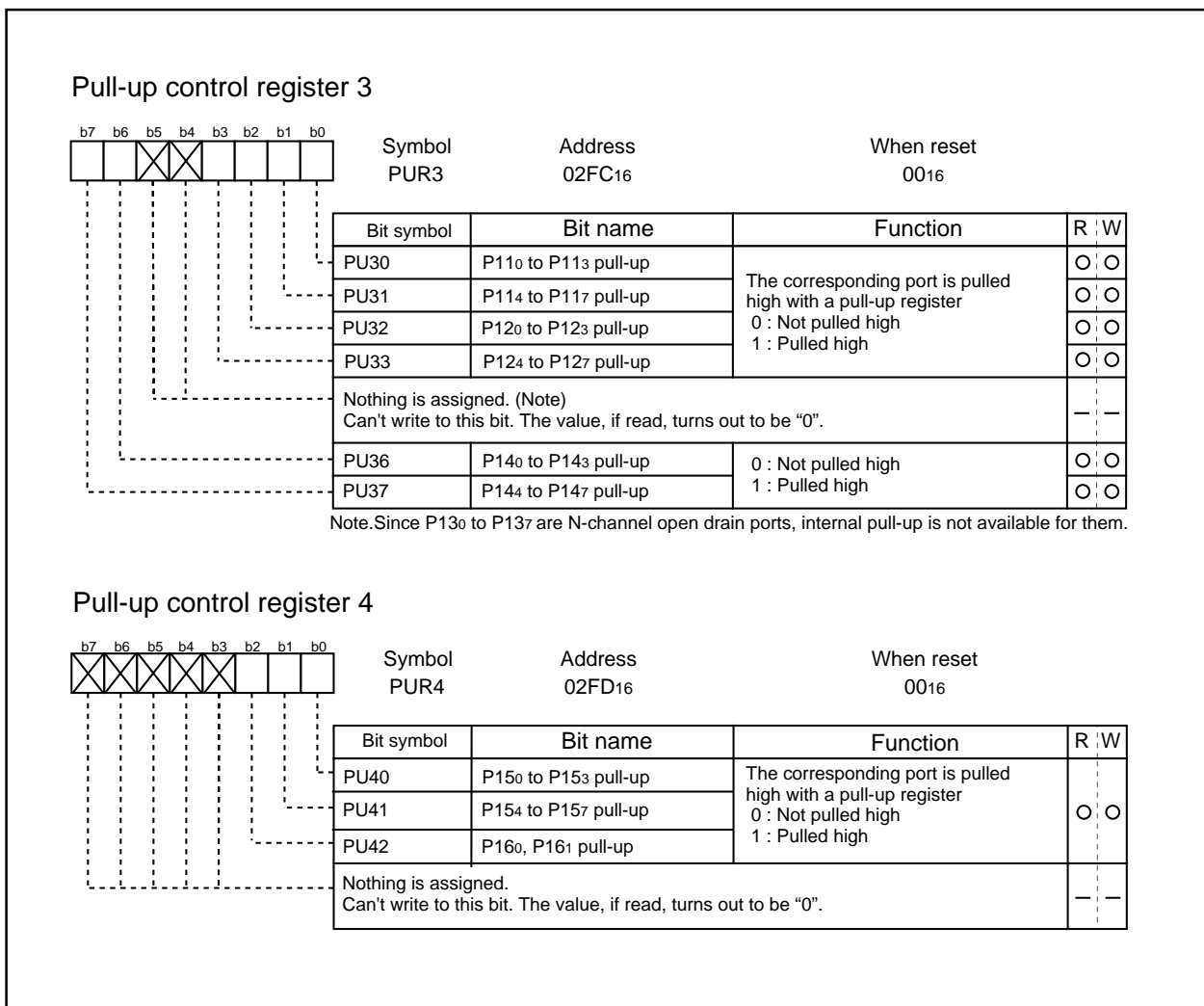

Fig.UA-10 Pull-up control register(2)

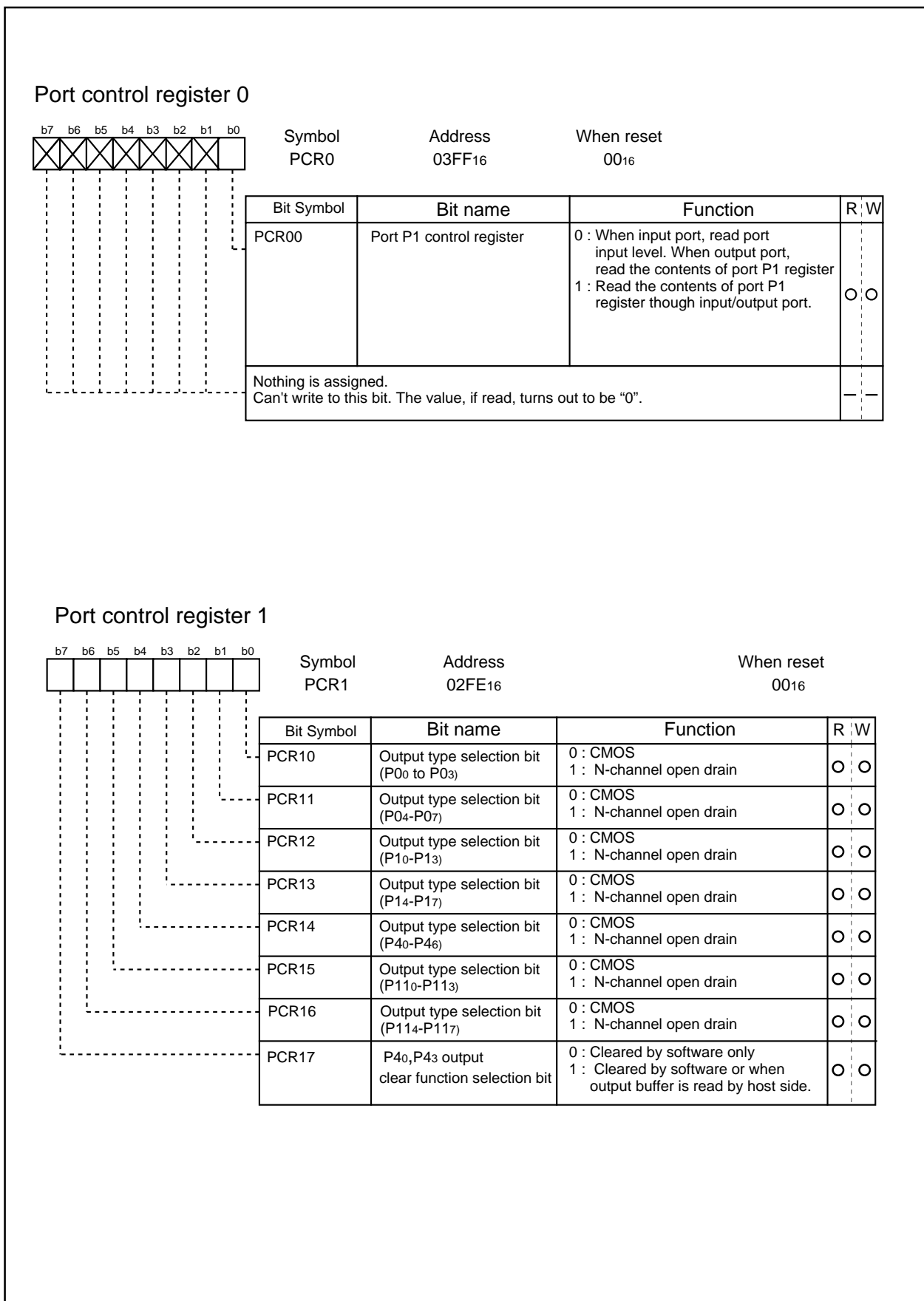

Fig.UA-11 Port control register 0, 1



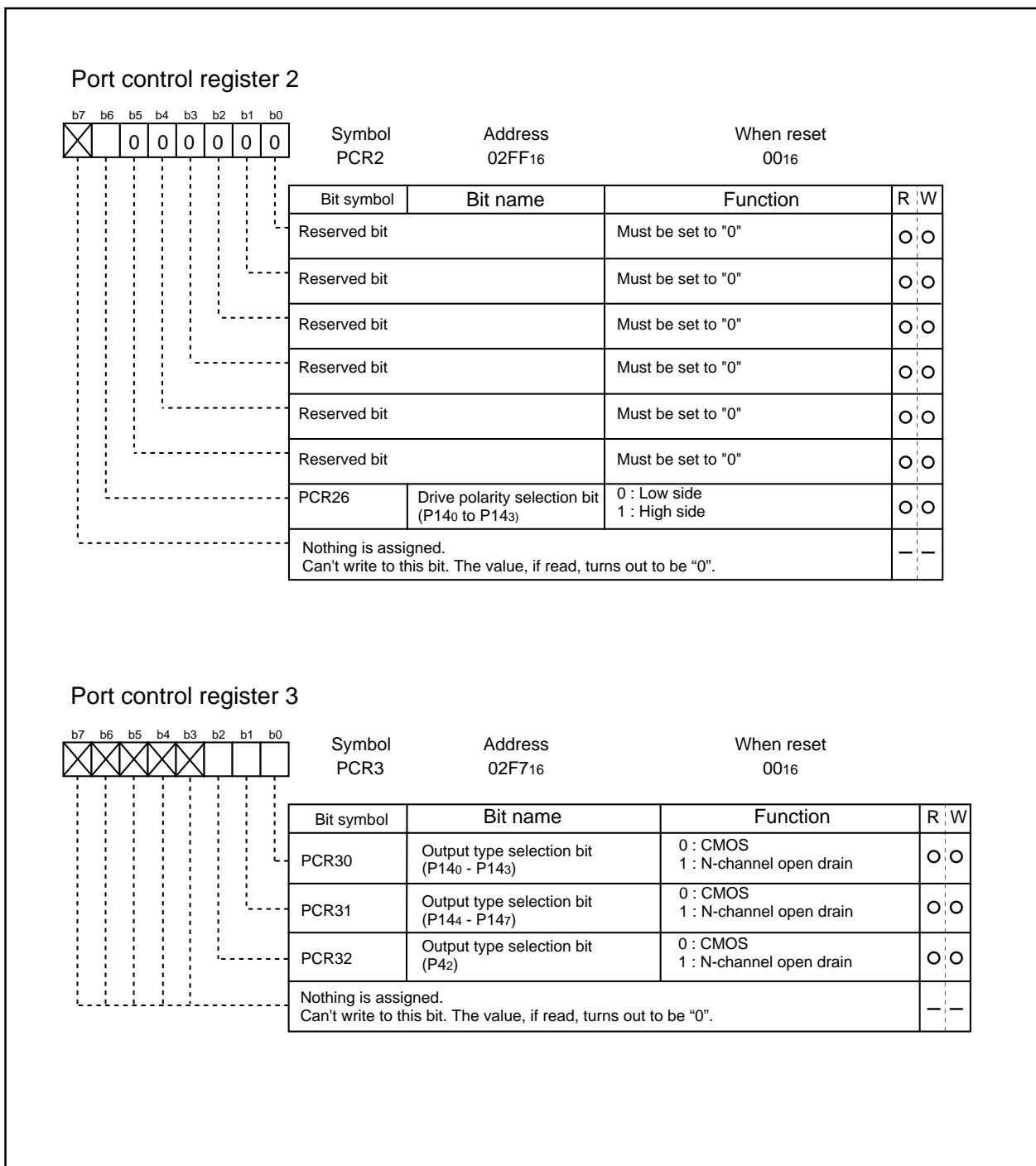

Fig.UA-12 Port control register 2, 3

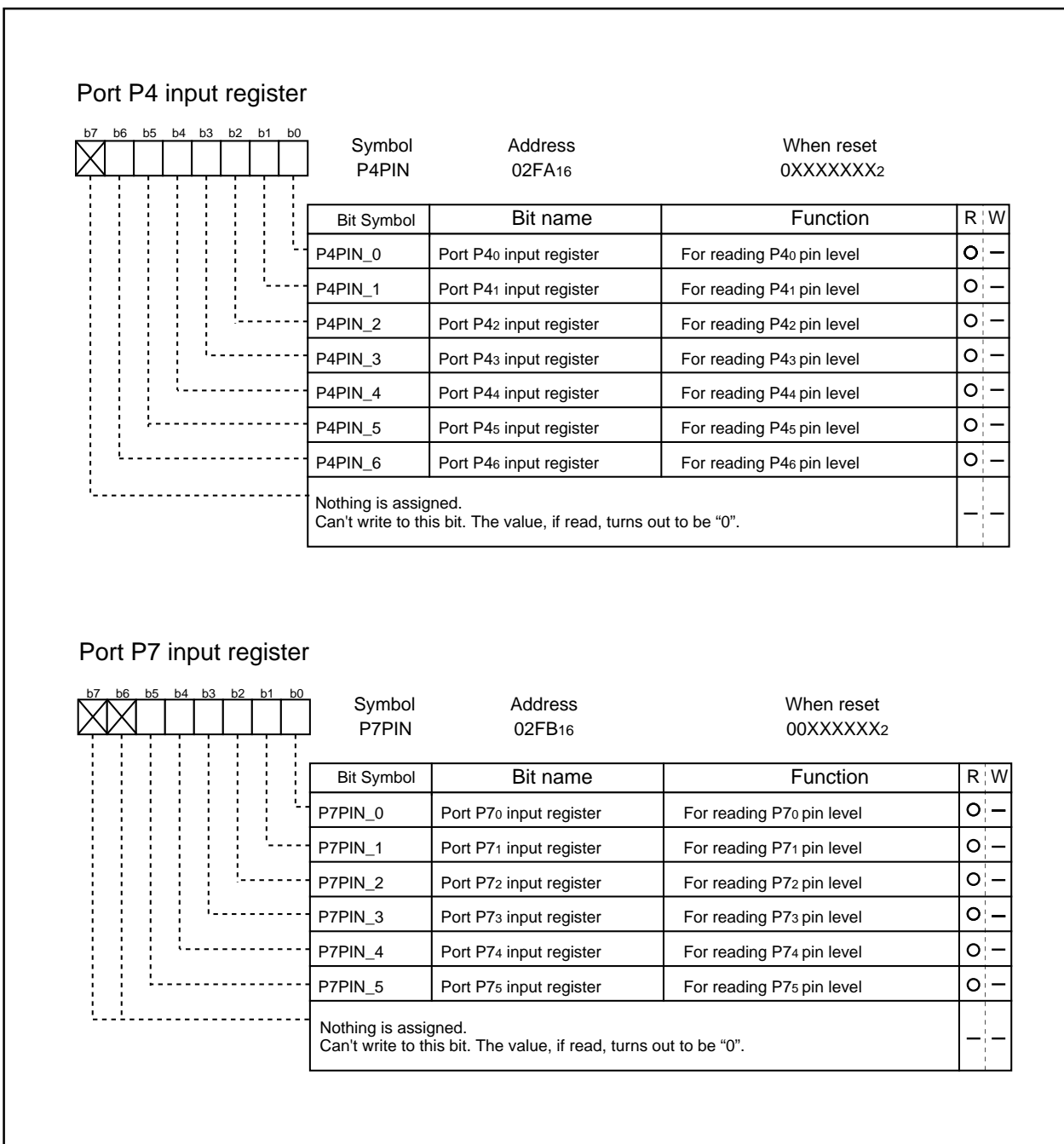
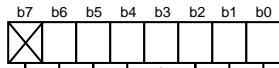

Fig.UA-13 Port P4,P7 input register

Port function selection register 0



Symbol: PSL0  
 Address: 02F8<sub>16</sub>  
 When reset: 00<sub>16</sub>

Bit Symbol	Bit name	Function	R	W
PSL00	UART0 I/O pin selection bit	0 : P6 <sub>0</sub> -P6 <sub>3</sub> 1 : P1 <sub>0</sub> -P1 <sub>3</sub>	○	○
PSL01	UART1 I/O pin selection bit	0 : P6 <sub>4</sub> -P6 <sub>7</sub> 1 : P1 <sub>4</sub> -P1 <sub>7</sub>	○	○
PSL02	UART2 I/O pin selection bit	0 : P7 <sub>0</sub> -P7 <sub>3</sub> 1 : P2 <sub>0</sub> -P2 <sub>3</sub>	○	○
PSL03	$\overline{\text{INT7}}$ input pin selection bit	0 : P10 <sub>3</sub> 1 : P1 <sub>4</sub>	○	○
PSL04	$\overline{\text{INT8}}$ I/O pin selection bit	0 : P10 <sub>4</sub> 1 : P1 <sub>5</sub>	○	○
PSL05	$\overline{\text{INT9}}$ I/O pin selection bit	0 : P10 <sub>5</sub> 1 : P1 <sub>6</sub>	○	○
PSL06	$\overline{\text{INT10}}$ I/O pin selection bit	0 : P10 <sub>6</sub> 1 : P1 <sub>7</sub>	○	○
Reserved bit		Must be set to "0"	○	○

Port function selection register 1

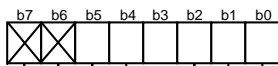

Symbol: PSL1  
 Address: 02F9<sub>16</sub>  
 When reset: 00<sub>16</sub>

Bit Symbol	Bit name	Function	R	W
PSL10	TA0 output pin selection bit	0 : P4 <sub>0</sub> 1 : P15 <sub>0</sub>	○	○
PSL11	TA1 output pin selection bit	0 : P4 <sub>1</sub> 1 : P15 <sub>1</sub>	○	○
PSL12	TA2 output pin selection bit	0 : P4 <sub>2</sub> 1 : P15 <sub>2</sub>	○	○
PSL13	TB3 output pin selection bit	0 : P9 <sub>3</sub> 1 : P16 <sub>0</sub>	○	○
PSL14	TB4 output pin selection bit	0 : P9 <sub>4</sub> 1 : P16 <sub>1</sub>	○	○
PSL15(Note)	$\overline{\text{INT6}}-\overline{\text{INT11}}$ input pin switching bit	0 : P9 <sub>7</sub> , P10 <sub>3</sub> -P10 <sub>7</sub> 1 : P12 <sub>0</sub> , P12 <sub>1</sub> -P12 <sub>5</sub>	○	○
PSL16	P6 <sub>6</sub> : f1 output function selection bit	0 : P6 <sub>6</sub> as GPIO 1 : P6 <sub>6</sub> as f1 output	—	—
PSL17	P6 <sub>7</sub> : f1 output function selection bit	0 : P6 <sub>7</sub> as GPIO 1 : P6 <sub>7</sub> as f1 output	—	—

Note. If this is set to "1" then port function selection register 1 (address 02F8<sub>16</sub>) bit 3 to bit6 setting will be ignored.

Fig.UA-14 Port function register 0,1

**Table.UA-1 Example connection of unused pins in single-chip mode**

Pin name	Connection
Ports P0 to P10 (excluding P85)	After setting for input mode, connect every pin to Vss or Vcc via a resistor; or after setting for output mode, leave these pins open.
Ports P11 to P16	After setting for input mode, connect every pin to Vss or Vcc via a resistor; or after setting for output mode, leave these pins open.
XOUT (Note)	Open
$\overline{\text{NMI}}$	Connect via resistor to Vcc (pull-up)
AVcc	Connect to Vcc
AVss, VREF, M1	Connect to Vss

Note: With external clock input to XIN pin.

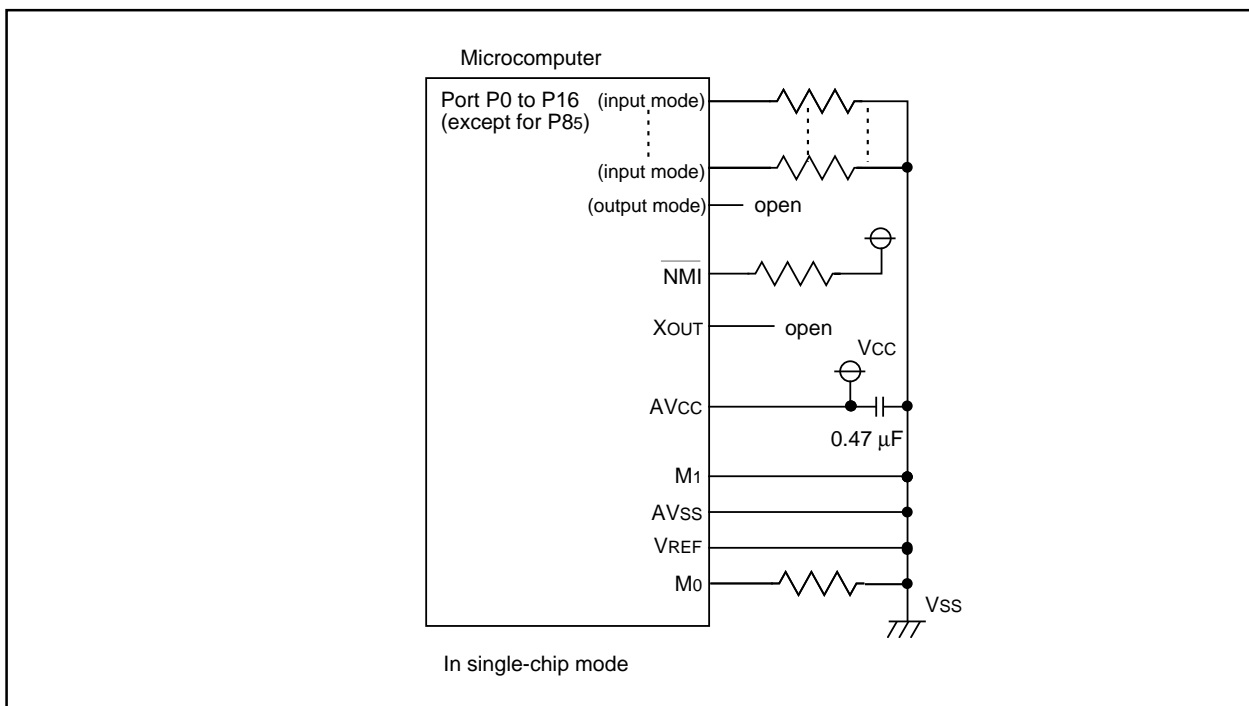
**Fig.UA-15 Example connection of unused pins**

## Usage Precaution

### Timer A (timer mode)

- (1) Reading the timer Ai register while a count is in progress allows reading, with arbitrary timing, the value of the counter. But, reading the timer Ai register with the reload timing gets "FFFF16". Reading the timer Ai register after setting a value in the timer Ai register with a count halted but before the counter starts counting gets a setting value to the timer.

### Timer A (event counter mode)

- (1) Reading the timer Ai register while a count is in progress allows reading, with arbitrary timing, the value of the counter. But, reading the timer Ai register with the reload timing gets "FFFF16" by underflow or "000016" by overflow. Reading the timer Ai register after setting a value in the timer Ai register with a count halted but before the counter starts counting gets a setting value to the timer.
- (2) When stop counting in free run type, set timer again.

### Timer A (one-shot timer mode)

- (1) Setting the count start flag to "0" while a count is in progress causes as follows:
- The counter stops counting and a content of reload register is reloaded.
  - The TAIOUT pin outputs "L" level.
  - The interrupt request generated and the timer Ai interrupt request bit goes to "1".
- (2) The timer Ai interrupt request bit goes to "1" if the timer's operation mode is set using any of the following procedures:
- Selecting one-shot timer mode after reset.
  - Changing operation mode from timer mode to one-shot timer mode.
  - Changing operation mode from event counter mode to one-shot timer mode.
- Therefore, to use timer Ai interrupt (interrupt request bit), set timer Ai interrupt request bit to "0" after the above listed changes have been made.

### Timer A (pulse width modulation mode)

- (1) The timer Ai interrupt request bit becomes "1" if setting operation mode of the timer in compliance with any of the following procedures:
- Selecting PWM mode after reset.
  - Changing operation mode from timer mode to PWM mode.
  - Changing operation mode from event counter mode to PWM mode.
- Therefore, to use timer Ai interrupt (interrupt request bit), set timer Ai interrupt request bit to "0" after the above listed changes have been made.
- (2) Setting the count start flag to "0" while PWM pulses are being output causes the counter to stop counting. If the TAIOUT pin is outputting an "H" level in this instance, the output level goes to "L", and the timer Ai interrupt request bit goes to "1". If the TAIOUT pin is outputting an "L" level in this instance, the level does not change, and the timer Ai interrupt request bit does not becomes "1".

### Timer B (timer mode, event counter mode)

- (1) Reading the timer Bi register while a count is in progress allows reading, with arbitrary timing, the value of the counter. But, reading the timer Bi register with the reload timing gets "FFFF16". Reading the timer Bi register after setting a value in the timer Bi register with a count halted but before the counter starts counting gets a setting value to the timer.

**Timer B (pulse period/pulse width measurement mode)**

- (1) If changing the measurement mode select bit is set after a count is started, the timer Bi interrupt request bit goes to "1".
- (2) When the first effective edge is input after a count is started, an indeterminate value is transferred to the reload register. At this time, timer Bi interrupt request is not generated.

**A-D Converter**

- (1) Write to each bit (except bit 6) of A-D control register 0, to each bit of A-D control register 1, and to bit 0 of A-D control register 2 when A-D conversion is stopped (before a trigger occurs).  
In particular, when the Vref connection bit is changed from "0" to "1", start A-D conversion after an elapse of 1  $\mu$ s or longer.
- (2) When changing A-D operation mode, select analog input pin again.
- (3) Using one-shot mode or single sweep mode  
Read the correspondence A-D register after confirming A-D conversion is finished. (It is known by A-D conversion interrupt request bit.)
- (4) Using repeat mode, repeat sweep mode 0 or repeat sweep mode 1  
Use the undivided main clock as the internal CPU clock.

**Stop Mode and Wait Mode**

- (1) When returning from stop mode by hardware reset,  $\overline{\text{RESET}}$  pin must be set to "L" level until main clock oscillation is stabilized.
- (2) When switching to either wait mode or stop mode, instructions occupying four bytes either from the WAIT instruction or from the instruction that sets the every-clock stop bit to "1" within the instruction queue are prefetched and then the program stops. So put at least four NOPs in succession either to the WAIT instruction or to the instruction that sets the every-clock stop bit to "1".

**Interrupts**

- (1) Reading address 00000<sub>16</sub>
  - When maskable interrupt is occurred, CPU read the interrupt information (the interrupt number and interrupt request level) in the interrupt sequence.  
The interrupt request bit of the certain interrupt written in address 00000<sub>16</sub> will then be set to "0".  
Reading address 00000<sub>16</sub> by software sets enabled highest priority interrupt source request bit to "0".  
Though the interrupt is generated, the interrupt routine may not be executed.  
Do not read address 00000<sub>16</sub> by software.
- (2) Setting the stack pointer
  - The value of the stack pointer immediately after reset is initialized to 0000<sub>16</sub>. Accepting an interrupt before setting a value in the stack pointer may become a factor of runaway. Be sure to set a value in the stack pointer before accepting an interrupt.  
When using the  $\overline{\text{NMI}}$  interrupt, initialize the stack point at the beginning of a program. Concerning the first instruction immediately after reset, generating any interrupts including the  $\overline{\text{NMI}}$  interrupt is prohibited.
- (3) The  $\overline{\text{NMI}}$  interrupt
  - As for the  $\overline{\text{NMI}}$  interrupt pin, an interrupt cannot be disabled. Connect it to the VCC pin via a resistor (pull-up) if unused. Be sure to work on it.
  - Do not get either into stop mode with the  $\overline{\text{NMI}}$  pin set to "L".

## (4) External interrupt

- When the polarity of the  $\overline{\text{INT0}}$  to  $\overline{\text{INT11}}$  pins is changed, the interrupt request bit is sometimes set to "1". After changing the polarity, set the interrupt request bit to "0".

## (5) Rewrite the interrupt control register

- To rewrite the interrupt control register, do so at a point that does not generate the interrupt request for that register. If there is possibility of the interrupt request occur, rewrite the interrupt control register after the interrupt is disabled. The program examples are described as follow:

**Example 1:**

```

INT_SWITCH1:
  FCLR  I           ; Disable interrupts.
  AND.B #00h, 0055h ; Clear TA0IC int. priority level and int. request bit.
  NOP                               ; Four NOP instructions are required when using HOLD function.
  NOP
  FSET  I           ; Enable interrupts.

```

**Example 2:**

```

INT_SWITCH2:
  FCLR  I           ; Disable interrupts.
  AND.B #00h, 0055h ; Clear TA0IC int. priority level and int. request bit.
  MOV.W MEM, R0    ; Dummy read.
  FSET  I           ; Enable interrupts.

```

**Example 3:**

```

INT_SWITCH3:
  PUSHC FLG        ; Push Flag register onto stack
  FCLR  I           ; Disable interrupts.
  AND.B #00h, 0055h ; Clear TA0IC int. priority level and int. request bit.
  POPC  FLG        ; Enable interrupts.

```

The reason why two NOP instructions (four when using the HOLD function) or dummy read are inserted before FSET I in Examples 1 and 2 is to prevent the interrupt enable flag I from being set before the interrupt control register is rewritten due to effects of the instruction queue.

- When a instruction to rewrite the interrupt control register is executed but the interrupt is disabled, the interrupt request bit is not set sometimes even if the interrupt request for that register has been generated. This will depend on the instruction. If this creates problems, use the below instructions to change the register.

Instructions : AND, OR, BCLR, BSET

## Noise

- (1) Insert the by-pass condenser to the Vcc-Vss line for preventing a noise and latch-up. Connect the by-pass condenser (about 0.1 $\mu$ F) between Vcc pin and Vss pin. It is distance must be shortest rather sicker line.

Table.ZA-1 Absolute maximum ratings

Symbol	Parameter		Condition	Rated value	Unit
V <sub>cc</sub>	Supply voltage		V <sub>cc</sub> =AV <sub>cc</sub>	-0.3 to 4.6	V
AV <sub>cc</sub>	Analog Supply voltage		V <sub>cc</sub> =AV <sub>cc</sub>	-0.3 to 4.6	V
V <sub>i</sub>	Input voltage	RESET, M0, M1, V <sub>REF</sub> , X <sub>IN</sub> , P0 <sub>0</sub> to P0 <sub>7</sub> , P1 <sub>0</sub> to P1 <sub>7</sub> , P2 <sub>0</sub> to P2 <sub>7</sub> , P3 <sub>0</sub> to P3 <sub>7</sub> , P4 <sub>0</sub> to P4 <sub>7</sub> , P5 <sub>0</sub> to P5 <sub>7</sub> , P6 <sub>4</sub> to P6 <sub>7</sub> , P8 <sub>6</sub> , P8 <sub>7</sub> , P9 <sub>0</sub> to P9 <sub>7</sub> , P10 <sub>0</sub> to P10 <sub>7</sub> , P11 <sub>0</sub> to P11 <sub>7</sub> , P12 <sub>0</sub> to P12 <sub>7</sub> , P14 <sub>0</sub> to P14 <sub>7</sub> , P15 <sub>0</sub> to P15 <sub>7</sub> , P16 <sub>0</sub> , P16 <sub>1</sub>		-0.3 to V <sub>cc</sub> +0.3	V
		P6 <sub>0</sub> to P6 <sub>3</sub> , P7 <sub>0</sub> to P7 <sub>7</sub> , P8 <sub>0</sub> to P8 <sub>5</sub> , P13 <sub>0</sub> to P13 <sub>7</sub>		-0.3 to 5.8	V
V <sub>o</sub>	output voltage	P0 <sub>0</sub> to P0 <sub>7</sub> , P1 <sub>0</sub> to P1 <sub>7</sub> , P2 <sub>0</sub> to P2 <sub>7</sub> , P3 <sub>0</sub> to P3 <sub>7</sub> , P4 <sub>0</sub> to P4 <sub>7</sub> , P5 <sub>0</sub> to P5 <sub>7</sub> , P6 <sub>4</sub> to P6 <sub>7</sub> , P8 <sub>6</sub> , P8 <sub>7</sub> , P9 <sub>0</sub> to P9 <sub>7</sub> , P10 <sub>0</sub> to P10 <sub>7</sub> , P11 <sub>0</sub> to P11 <sub>7</sub> , P12 <sub>0</sub> to P12 <sub>7</sub> , P14 <sub>0</sub> to P14 <sub>7</sub> , P15 <sub>0</sub> to P15 <sub>7</sub> , P16 <sub>0</sub> , P16 <sub>1</sub> , X <sub>OUT</sub>		-0.3 to V <sub>cc</sub> +0.3	V
		P6 <sub>0</sub> to P6 <sub>3</sub> , P7 <sub>0</sub> to P7 <sub>7</sub> , P8 <sub>0</sub> to P8 <sub>4</sub> , P13 <sub>0</sub> to P13 <sub>7</sub>		-0.3 to 5.8	V
P <sub>d</sub>	Power dissipation		T <sub>a</sub> =25 °C	300	mW
T <sub>opr</sub>	Operating ambient temperature			-20 to 85	°C
T <sub>stg</sub>	Storage temperature			-40 to 125	°C



Table.ZA-2 Recommended operating conditions (referenced to  $V_{CC}=3.0V$  to  $3.6V$ ,  $T_a = -20$  to  $85^\circ C$ )

Symbol	Parameter		Standard			Unit
			Min.	Typ.	Max.	
$V_{CC}$	Supply voltage		3.0	3.3	3.6	V
$AV_{CC}$	Analog Supply voltage			$V_{CC}$		V
$V_{SS}$	Supply voltage			0		V
$AV_{SS}$	Analog Supply voltage			0		V
$V_{IH}$	"H" input voltage	P00 to P07, P10 to P17, P20 to P27, P30 to P37, P40 to P47, P50 to P57, P64 to P67, P86, P87, P90 to P97, P100 to P107, P110 to P117, P120 to P127, P140 to P147, P150 to P157, P160, P161, XIN, RESET, M0, M1	0.8V <sub>CC</sub>		$V_{CC}$	V
		P60 to P63, P70 to P77, P80 to P84, P85, P130 to P137, PSA0 to PSA2, PSB0 to PSB2	0.8V <sub>CC</sub>		5.5	V
		LAD0 to LAD3, LFARAME, LCLK, SERIRQ, CLKRUN	0.6V <sub>CC</sub>		$V_{CC}$	V
		SDA0, SCL0, SDA1, SCL1, P60 to P63	$I^2C$ -BUS input level selected	0.7V <sub>CC</sub>		5.5
	SMBUS input level selected	1.4		5.5		
$V_{IL}$	"L" input voltage	P00 to P07, P10 to P17, P20 to P27, P30 to P37, P40 to P47, P50 to P57, P64 to P67, P86, P87, P90 to P97, P100 to P107, P110 to P117, P120 to P127, P140 to P147, P150 to P157, P160, P161, XIN, RESET, M0, M1	0		0.2V <sub>CC</sub>	V
		P60 to P63, P70 to P77, P80 to P84, P85, P130 to P137, PSA0 to PSA2, PSB0 to PSB2	0		0.2V <sub>CC</sub>	V
		LAD0 to LAD3, LFARAME, LCLK, SERIRQ, CLKRUN	0		0.2V <sub>CC</sub>	V
		SDA0, SCL0, SDA1, SCL1, P60 to P63	$I^2C$ -BUSes input level selected	0		0.3V <sub>CC</sub>
	SMBUS input level selected	0		0.6		

**Table.ZA-3 Recommended operating conditions (referenced to Vcc=3.0V to 3.6V, Ta= -20 to 85°C)**

Symbol	Parameter		Standard			Unit	
			Min.	Typ.	Max.		
I <sub>OH</sub> (peak)	"H" peak output current	P0 <sub>0</sub> to P0 <sub>7</sub> , P1 <sub>0</sub> to P1 <sub>7</sub> , P2 <sub>0</sub> to P2 <sub>7</sub> , P3 <sub>0</sub> to P3 <sub>7</sub> , P4 <sub>0</sub> to P4 <sub>7</sub> , P5 <sub>0</sub> to P5 <sub>7</sub> , P6 <sub>4</sub> to P6 <sub>7</sub> , P8 <sub>6</sub> to P8 <sub>7</sub> , P9 <sub>0</sub> to P9 <sub>7</sub> , P10 <sub>0</sub> to P10 <sub>7</sub> , P11 <sub>0</sub> to P11 <sub>7</sub> , P12 <sub>0</sub> to P12 <sub>7</sub> , P14 <sub>0</sub> to P14 <sub>7</sub> , P15 <sub>0</sub> to P15 <sub>7</sub> , P16 <sub>0</sub> , P16 <sub>1</sub>				-10.0	mA
I <sub>OL</sub> (peak)	"L" peak output current	P0 <sub>0</sub> to P0 <sub>7</sub> , P1 <sub>0</sub> to P1 <sub>7</sub> , P2 <sub>0</sub> to P2 <sub>3</sub> , P3 <sub>0</sub> to P3 <sub>7</sub> , P4 <sub>0</sub> to P4 <sub>7</sub> , P5 <sub>0</sub> to P5 <sub>7</sub> , P6 <sub>0</sub> to P6 <sub>7</sub> , P7 <sub>6</sub> to P7 <sub>7</sub> , P8 <sub>0</sub> to P8 <sub>4</sub> , P8 <sub>6</sub> to P8 <sub>7</sub> , P9 <sub>0</sub> to P9 <sub>7</sub> , P10 <sub>0</sub> to P10 <sub>7</sub> , P11 <sub>0</sub> to P11 <sub>7</sub> , P12 <sub>0</sub> to P12 <sub>7</sub> , P13 <sub>0</sub> to P13 <sub>7</sub> , P14 <sub>4</sub> to P14 <sub>7</sub> , P15 <sub>0</sub> to P15 <sub>7</sub> , P16 <sub>0</sub> , P16 <sub>1</sub>				10.0	mA
		P2 <sub>4</sub> to P2 <sub>7</sub>				20.0	mA
I <sub>OL</sub> (peak)	"L" peak output current	P14 <sub>0</sub> to P14 <sub>3</sub>	Driven ability: High			20.0	mA
			Driven ability: Low			10.0	mA
I <sub>OH</sub> (avg)	"H" average output current	P0 <sub>0</sub> to P0 <sub>7</sub> , P1 <sub>0</sub> to P1 <sub>7</sub> , P2 <sub>0</sub> to P2 <sub>7</sub> , P3 <sub>0</sub> to P3 <sub>7</sub> , P4 <sub>0</sub> to P4 <sub>7</sub> , P5 <sub>0</sub> to P5 <sub>7</sub> , P6 <sub>0</sub> to P6 <sub>7</sub> , P8 <sub>6</sub> to P8 <sub>7</sub> , P9 <sub>0</sub> to P9 <sub>7</sub> , P10 <sub>0</sub> to P10 <sub>7</sub> , P11 <sub>0</sub> to P11 <sub>7</sub> , P12 <sub>0</sub> to P12 <sub>7</sub> , P14 <sub>0</sub> to P14 <sub>7</sub> , P15 <sub>0</sub> to P15 <sub>7</sub> , P16 <sub>0</sub> , P16 <sub>1</sub>				-5.0	mA
I <sub>OL</sub> (avg)	"L" average output current	P0 <sub>0</sub> to P0 <sub>7</sub> , P1 <sub>0</sub> to P1 <sub>7</sub> , P2 <sub>0</sub> to P2 <sub>3</sub> , P3 <sub>0</sub> to P3 <sub>7</sub> , P4 <sub>0</sub> to P4 <sub>7</sub> , P5 <sub>0</sub> to P5 <sub>7</sub> , P6 <sub>0</sub> to P6 <sub>7</sub> , P7 <sub>6</sub> to P7 <sub>7</sub> , P8 <sub>0</sub> to P8 <sub>4</sub> , P8 <sub>6</sub> to P8 <sub>7</sub> , P9 <sub>0</sub> to P9 <sub>7</sub> , P10 <sub>0</sub> to P10 <sub>7</sub> , P11 <sub>0</sub> to P11 <sub>7</sub> , P12 <sub>0</sub> to P12 <sub>7</sub> , P13 <sub>0</sub> to P13 <sub>7</sub> , P14 <sub>0</sub> to P14 <sub>7</sub> , P15 <sub>0</sub> to P15 <sub>7</sub> , P16 <sub>0</sub> , P16 <sub>1</sub>				5.0	mA
		P2 <sub>4</sub> to P2 <sub>7</sub>				15.0	mA
I <sub>OL</sub> (avg)	"L" average output current	P14 <sub>0</sub> to P14 <sub>3</sub>	Driven ability: High			15.0	mA
			Driven ability: Low			5.0	mA
f (X <sub>IN</sub> )	Main clock input oscillation frequency	Non wait		0		4	MHz
		With wait		0		8	MHz
f (X <sub>CIN</sub> )	Subclock oscillation frequency			32.768	50	kHz	

Note1 : The average output current is the average value during the 100ms period limited current.

Note2 : The value are as follow:

- The sum of I<sub>OL</sub> (peak) of P0<sub>0</sub>, P1<sub>0</sub>, P2<sub>0</sub>, P8<sub>6</sub> to P8<sub>7</sub>, P9<sub>0</sub>, P10<sub>0</sub>, P11<sub>0</sub>, P12<sub>0</sub> to P12<sub>6</sub>, P15<sub>3</sub> to P15<sub>7</sub> P16 should be under 80mA.
- The sum of I<sub>OH</sub> (peak) of P0<sub>0</sub>, P1<sub>0</sub>, P2<sub>0</sub>, P8<sub>6</sub> to P8<sub>7</sub>, P9<sub>0</sub>, P10<sub>0</sub>, P11<sub>0</sub>, P12<sub>0</sub> to P12<sub>6</sub>, P15<sub>3</sub> to P15<sub>7</sub> P16 should be under 80mA.
- The sum of I<sub>OL</sub> (peak) of P3<sub>0</sub>, P4<sub>0</sub>, P5<sub>0</sub>, P6<sub>0</sub>, P7<sub>0</sub>, P8<sub>0</sub> to P8<sub>4</sub>, P13<sub>0</sub>, P14<sub>0</sub>, P15<sub>0</sub> to P15<sub>2</sub> should be under 80mA.
- The sum of I<sub>OH</sub> (peak) of P3<sub>0</sub>, P4<sub>0</sub>, P5<sub>0</sub>, P6<sub>4</sub> to P6<sub>7</sub>, P14<sub>0</sub>, P15<sub>0</sub> to P15<sub>2</sub> should be under 80mA.

**Table.ZA-4 Electorical characteristic (referenced to Vcc=3.0V,Vss=0V,Ta=25°C,f(XIN)=8MHz with WAIT)**

Symbol	Parameter		Measuring condition	Standard			Unit
				Min.	Typ.	Max.	
VOH	High output voltage	P00 to P07, P10 to P17, P20 to P27, P30 to P37, P40 to P47, P50 to P57, P64 to P67, P86, P87, P90 to P97, P100 to P107, P110 to P117, P120 to P127, P140 to P147, P150 to P157, P160, P161	IOH=-1mA	2.5			V
VOH	High output voltage	XOUT	HIGH POWER	IOH=-0.1mA	2.5		V
			LOWPOWER	IOH=-50μA	2.5		
	High output voltage	XCOUT	HIGHPOWER	With no load applied		3.0	V
			LOWPOWER	With no load applied		1.6	
VOL	Low output voltage	P00 to P07, P10 to P17, P20 to P23, P30 to P37, P40 to P47, P50 to P57, P60 to P67, P70 to P77, P80 to P84, P86, P87, P90 to P97, P100 to P107, P110 to P117, P120 to P127, P130 to P137, P140 to P147, P150 to P157, P160, P161	IOL=1mA			0.5	V
		P24 to P27	Vcc=3V, IOl=3mA			0.5	V
VOL	Low output voltage	P140 to P143	HIGH POWER	IOl=3mA		0.5	V
			LOWPOWER	IOl=1mA		0.5	V
VOL	Low output voltage	XOUT	HIGH POWER	IOH=0.1mA		0.5	V
			LOWPOWER	IOH=50μA		0.5	
	Low output voltage	XCOUT	HIGHPOWER	With no load applied		0	V
			LOWPOWER	With no load applied		0	
VT+VT-	Hysteresis	TA0IN to TA4IN, TB0IN to TB5IN, INT0 to INT11, ADTRG, CTS0, CTS1, CTS2, CLK0, CLK1, CLK2, CLK3, CLK4, SIN3, SIN4, RXD0, RXD1, RXD2, ICCK, NMI, KI00 to KI07		0.2		0.8	
VT+VT-	Hysteresis	RESET		0.2		1.8	V
I <sub>IH</sub>	HIGH input current	P00 to P07, P10 to P17, P20 to P27, P30 to P37, P40 to P47, P50 to P57, P60 to P67, P70 to P77, P80 to P87, P90 to P97, P100 to P107, P120 to P127, P130 to P137, P140 to P147, P150 to P157, P160, P161, XIN, RESET, M0, M1	Vi=3V			4.0	μA
I <sub>IL</sub>	Low input current	P00 to P07, P10 to P17, P20 to P27, P30 to P37, P40 to P47, P50 to P57, P60 to P67, P70 to P77, P80 to P87, P90 to P97, P100 to P107, P110 to P117, P120 to P127, P130 to P137, P140 to P147, P150 to P157, P160, P161, XIN, RESET, M0, M1	Vi=0V			-4.0	μA
R <sub>PULLUP</sub>	Pull-up resistance	P00 to P07, P10 to P17, P20 to P27, P30 to P37, P40 to P47, P50 to P57, P64 to P67, P86, P87, P90 to P97, P100 to P107, P110 to P117, P120 to P127, P140 to P147, P150 to P157, P160, P161	Vi=0V	66.0	120.0	500.0	kΩ
R <sub>fXIN</sub>	Feedback resistance	XIN			3.0		MΩ
R <sub>fXCIN</sub>	Feedback resistance	XCIN			10.0		MΩ
V <sub>RAM</sub>	RAM retention voltage		When clock is stopped	2.0			V
I <sub>CC</sub>	Power supply current	When reset, the output pins are opened, the other pins are connected to Vss.	f(XIN)=8MHz, Square wave without division		12.5	24.25	mA
			f(XCIN)=32kHz, Square wave When operation under RAM		40.0		μA
			f(XCIN)=32kHz, Square wave When operation under Flash memory		300.0		μA
			f(XCIN)=32kHz, With WAIT oscillation capacity High (Note1)		4.5		μA
			f(XCIN)=32kHz, With WAIT oscillation capacity Low (Note1)		2.5		μA
			Ta=25°C When clock is stopprd			3.0	μA
			Ta=85°C When clock is stopprd			60.0	μA

**Table.ZA-5 A-D conversion characteristics (referenced to  $V_{CC}=AV_{CC}=V_{REF}=3V, V_{SS}=AV_{SS}=0V$  at  $T_a=25^\circ C, f(X_{IN})=8MHz$  unless otherwise specified)**

Symbol	Parameter	Measuring condition	Standard			Unit
			Min.	Typ.	Max.	
—	Resolution	$V_{REF}=V_{CC}$			10	Bits
—	Absolute accuracy	$V_{REF}=V_{CC}=3V, \theta_{AD}=f_{AD}/2$			$\pm 2$	LSB
—					$\pm 6$	LSB
$R_{LADDER}$	Ladder resistance	$V_{REF}=V_{CC}$	10		40	$k\Omega$
$t_{CONV}$	Conversion time	8 bit	12.25			$\mu s$
		10 bit	14.75			$\mu s$
$V_{REF}$	Reference voltage		2.7		$V_{CC}$	V
$V_{IA}$	Analog input voltage		0		$V_{REF}$	V

**Table.ZA-6 D-A conversion characteristics (referenced to  $V_{CC}=AV_{CC}=V_{REF}=3V, V_{SS}=AV_{SS}=0V$  at  $T_a=25^\circ C, f(X_{IN})=8MHz$  unless otherwise specified)**

Symbol	Parameter	Measuring condition	Standard			Unit
			Min.	Typ.	Max.	
-	Resolution				8	Bits
-	Absolute accuracy				1.0	%
$t_{su}$	Setup time				3	$\mu s$
$R_o$	Output resistance		4	10	20	$k\Omega$
$I_{VREF}$	Reference power supply input current	(Note1)			1.0	mA

Note1: This applies when using one D-A converter, with the D-A register for the unused D-A converter set to "0016".

The A-D converter's ladder resistance is not included.

When the content of D-A register is not "00", the  $I_{VREF}$  will also be sent even if  $V_{REF}$  is disconnected.

**Table.ZA-7 Comparator characteristics (referenced to  $V_{CC}=AV_{CC}=V_{REF}=3V$  to  $3.6V, V_{SS}=AV_{SS}=0V$  at  $T_a=25^\circ C$ )**

Symbol	Parameter	Measuring condition	Standard			Unit
			Min.	Typ.	Max.	
-	Resolution				4	Bits
-	Absolute accuracy				1/2	LSB
$T_{CONV}$	Conversion time	when $f(X_{IN}) = 8MHz$			3.5	$\mu s$
		when $f(X_{IN}) = 4MHz$			7	$\mu s$
$V_{IA}$	Analog input voltage		0		$V_{CC}$	V
$I_{IA}$	Analog input current				5.0	$\mu s$
$R_{LADDER}$	Ladder resistance		20	40	50	$k\Omega$

Timing requirements (referenced to  $V_{CC}=3V, V_{SS}=0V$  at  $T_a=25^{\circ}C$  unless otherwise specified)

Table.ZA-8 External clock input

Symbol	Parameter	Standard		Unit
		Min.	Max.	
$t_c$	External clock input cycle time	125		ns
$t_{w(H)}$	External clock input HIGH pulse width	50		ns
$t_{w(L)}$	External clock input LOW pulse width	50		ns
$t_r$	External clock rising time		18	ns
$t_f$	External clock falling time		18	ns

**Timing requirements (referenced to  $V_{CC}=3V, V_{SS}=0V$  at  $T_a=25^\circ C$  unless otherwise specified)****Table.ZA-9 Timer A input (The count input of event counter mode)**

Symbol	Parameter	Standard		Unit
		Min.	Max.	
$t_{c(TA)}$	TAiIN input cycle time	150		ns
$t_{w(TAH)}$	TAiIN input "H" pulse width	60		ns
$t_{w(TAL)}$	TAiIN input "L" pulse width	60		ns

**Table.ZA-10 Timer A input (The gating input of timer mode)**

Symbol	Parameter	Standard		Unit
		Min.	Max.	
$t_{c(TA)}$	TAiIN input cycle time	600		ns
$t_{w(TAH)}$	TAiIN input "H" pulse width	300		ns
$t_{w(TAL)}$	TAiIN input "L" pulse width	300		ns

**Table.ZA-11 Timer A input (The external trigger input of one shot timer mode)**

Symbol	Parameter	Standard		Unit
		Min.	Max.	
$t_{c(TA)}$	TAiIN input cycle time	300		ns
$t_{w(TAH)}$	TAiIN input "H" pulse width	150		ns
$t_{w(TAL)}$	TAiIN input "L" pulse width	150		ns

**Table.ZA-12 Timer A input (The external trigger input of pulse width modulation mode)**

Symbol	Parameter	Standard		Unit
		Min.	Max.	
$t_{w(TAH)}$	TAiIN input "H" pulse width	150		ns
$t_{w(TAL)}$	TAiIN input "L" pulse width	150		ns

**Table.ZA-13 Timer A input (The up down input of event counter mode)**

Symbol	Parameter	Standard		Unit
		Min.	Max.	
$t_{c(UP)}$	TAiOUT input cycle time	3000		ns
$t_{w(UPH)}$	TAiOUT input "H" pulse width	1500		ns
$t_{w(UPL)}$	TAiOUT input "L" pulse width	1500		ns
$t_{su(UP-TIN)}$	TAiOUT input setup time	600		ns
$t_{h(TIN-UP)}$	TAiOUT input hold time	600		ns

**Timing requirements (referenced to  $V_{CC}=3V, V_{SS}=0V$  at  $T_a=25^\circ C$  unless otherwise specified)****Table.ZA-14 Timer B input (The count input of event counter mode)**

Symbol	Parameter	Standard		Unit
		Min.	Max.	
$t_{c(TB)}$	TBiIN input cycle time (single edge count)	150		ns
$t_{w(TBH)}$	TBiIN input "H" pulse width (single edge count)	60		ns
$t_{w(TBL)}$	TBiIN input "L" pulse width (single edge count)	60		ns
$t_{c(TB)}$	TBiIN input cycle time (double edge count)	300		ns
$t_{w(TBH)}$	TBiIN input "H" pulse width (double edge count)	160		ns
$t_{w(TBL)}$	TBiIN input "L" pulse width (double edge count)	160		ns

**Table.ZA-15 Timer B input (Pulse period measurement mode)**

Symbol	Parameter	Standard		Unit
		Min.	Max.	
$t_{c(TB)}$	TBiIN input cycle time	600		ns
$t_{w(TBH)}$	TBiIN input "H" pulse width	300		ns
$t_{w(TBL)}$	TBiIN input "L" pulse width	300		ns

**Table.ZA-16 Timer B input (Pulse width measurement mode)**

Symbol	Parameter	Standard		Unit
		Min.	Max.	
$t_{c(TB)}$	TBiIN input cycle time	600		ns
$t_{w(TBH)}$	TBiIN input "H" pulse width	300		ns
$t_{w(TBL)}$	TBiIN input "L" pulse width	300		ns

**Table.ZA-17 A-D trigger input**

Symbol	Parameter	Standard		Unit
		Min.	Max.	
$t_{c(AD)}$	$\overline{ADTRG}$ input cycle time (The Min. of trigger)	1500		ns
$t_{w(ADL)}$	$\overline{ADTRG}$ input "L" pulse width	200		ns

**Table.ZA-18 Serial I/O**

Symbol	Parameter	Standard		Unit
		Min.	Max.	
$t_{c(CK)}$	CLKi input cycle time	300		ns
$t_{w(CKH)}$	CLKi input "H" pulse width	150		ns
$t_{w(CKL)}$	CLKi input "L" pulse width	150		ns
$t_{d(C-Q)}$	TxDi output delay time		160	ns
$t_{h(C-Q)}$	TxDi hold time	0		ns
$t_{su(D-C)}$	RxDi input setup time	50		ns
$t_{h(C-D)}$	RxDi input hold time	90		ns

**Table.ZA-19 External interrupt INTi input**

Symbol	Parameter	Standard		Unit
		Min.	Max.	
$t_{w(INH)}$	$\overline{INTi}$ input "H" pulse width	380		ns
$t_{w(INL)}$	$\overline{INTi}$ input "L" pulse width	380		ns

Timing requirements (referenced to  $V_{CC} = 3.0$  to  $3.6V$ ,  $V_{SS} = 0V$ ,  $T_a = 25^\circ C$ )

Table. ZA-20 Multi-master I<sup>2</sup>C-BUS line

Symbol	Parameter	Standard clock mode		High-speed clock mode		Unit
		Min.	Max.	Min.	Max.	
tBUF	Bus free time	4.7		1.3		$\mu s$
tHD;STA	The hold time in start condition	4.0		0.6		$\mu s$
tLOW	The hold time in SCL clock "0" status	4.7		1.3		$\mu s$
tR	SCL, SDA signals' rising time		1000	20+0.1Cb	300	ns
tHD;DAT	Data hold time	0		0	0.9	$\mu s$
tHIGH	The hold time in SCL clock "1" status	4.0		0.6		$\mu s$
tF	SCL, SDA signals' falling time		300	20+0.1Cb	300	ns
tsu;DAT	Data setup time	250		100		ns
tsu;STA	The setup time in restart condition	4.7		0.6		$\mu s$
tsu;STO	Stop condition setup time	4.0		0.6		$\mu s$

Table. ZA-21 PS2 interface (referenced to  $V_{CC} = 3.0$  to  $3.6V$ ,  $V_{SS} = 0V$ ,  $T_a = 25^\circ C$ )

Symbol	Parameter	Standard			Unit
		Min.	Typ.	Max.	
twL	PS2 clock "L" pulse width	30			$\mu s$
twH	PS2 clock "H" pulse width	30		50	$\mu s$
tsu	PS2 data setup time	5			$\mu s$
th	PS2 data hold time	0			ns
td	PS2 data delay time			twL-5	$\mu s$
tv	PS2 data valid time	0		twL-5	$\mu s$

Table. ZA-22 LPC bus interface/serial interrupt output

Symbol	Parameter	Standard			Unit
		Min.	Typ.	Max.	
tc(CLK)	LCLK clock input cycle time	30		$\infty$	ns
tWH(CLK)	LCLK clock input "H" pulse width	11			ns
tWL(CLK)	LCLK clock input "L" pulse width	11			ns
tsu(D-C)	Input setup time	LAD3-LAD0	9		ns
		LFRAME			
		SERIRQ,CLKRUN	7		ns
th(C-D)	LAD3-LAD0,SERIRQ,CLKRUN , LFRAME input hold time	0			ns
tv(C-D)	LAD3-LAD0,SERIRQ,CLKRUN output delay time	2		11	ns
toff(A-F)	LAD3-LAD0,SERIRQ,CLKRUN floating output delay time			28	ns



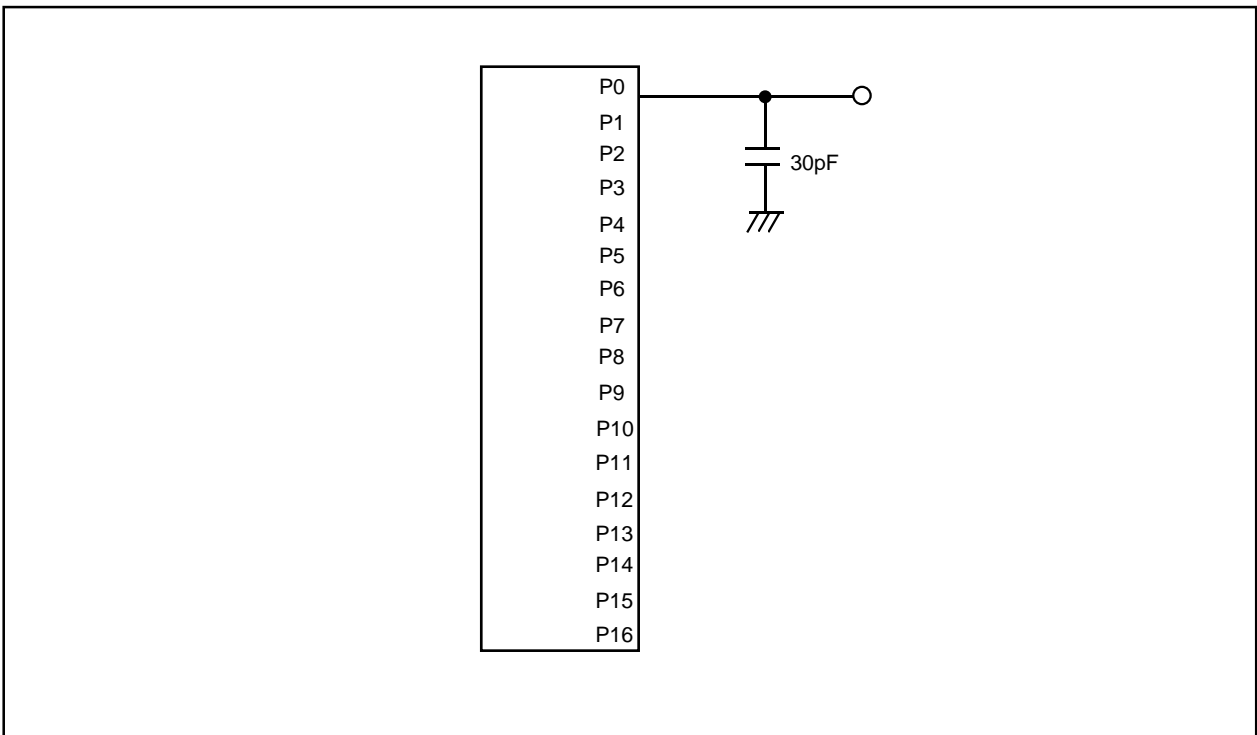

Fig.ZA-1 The measuring circuit for port 0 to port 16

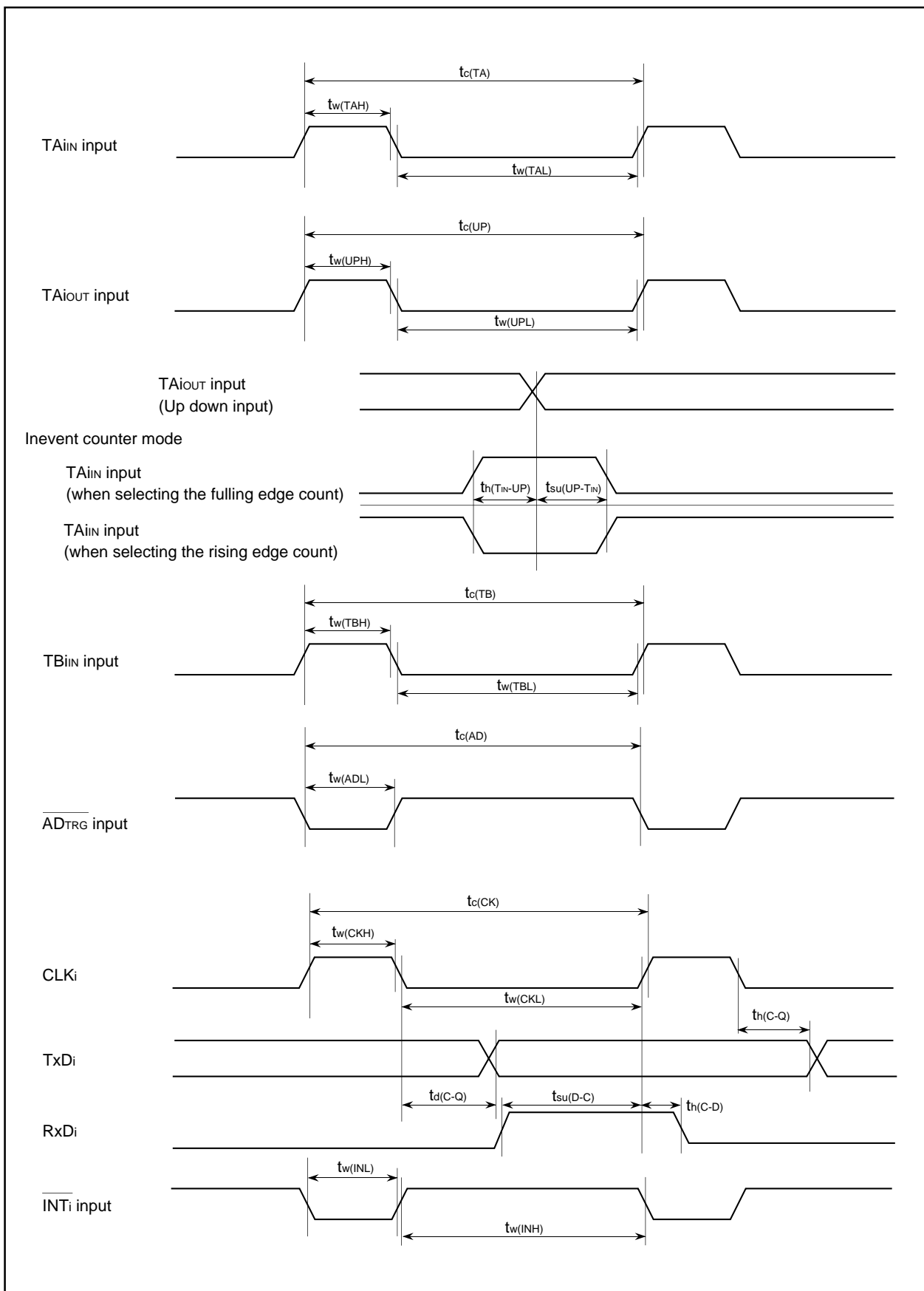

Fig.ZA-2 Timing diagram (1)

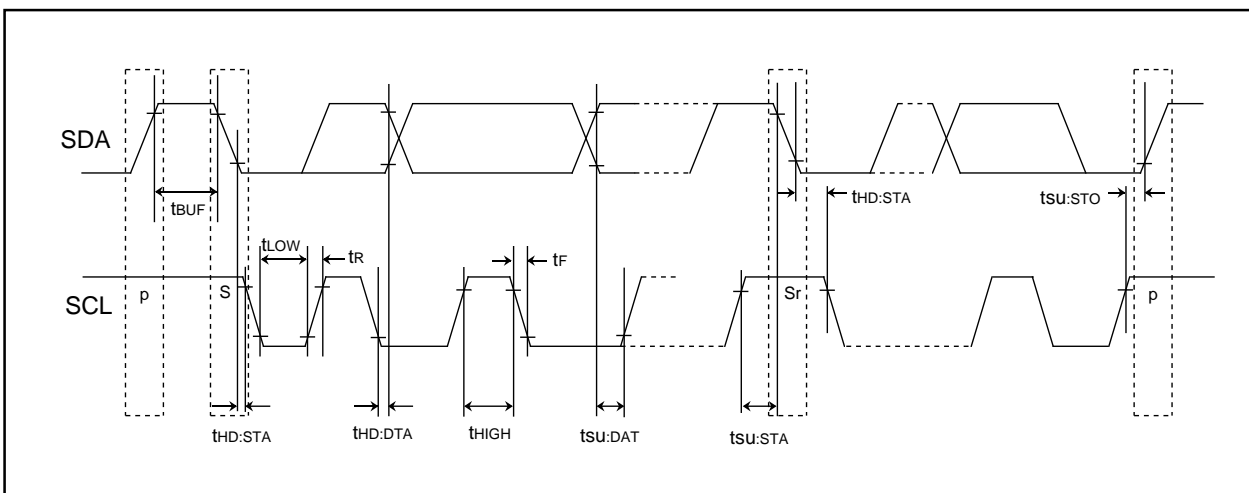

Fig.ZA-3 Timing diagram (2)

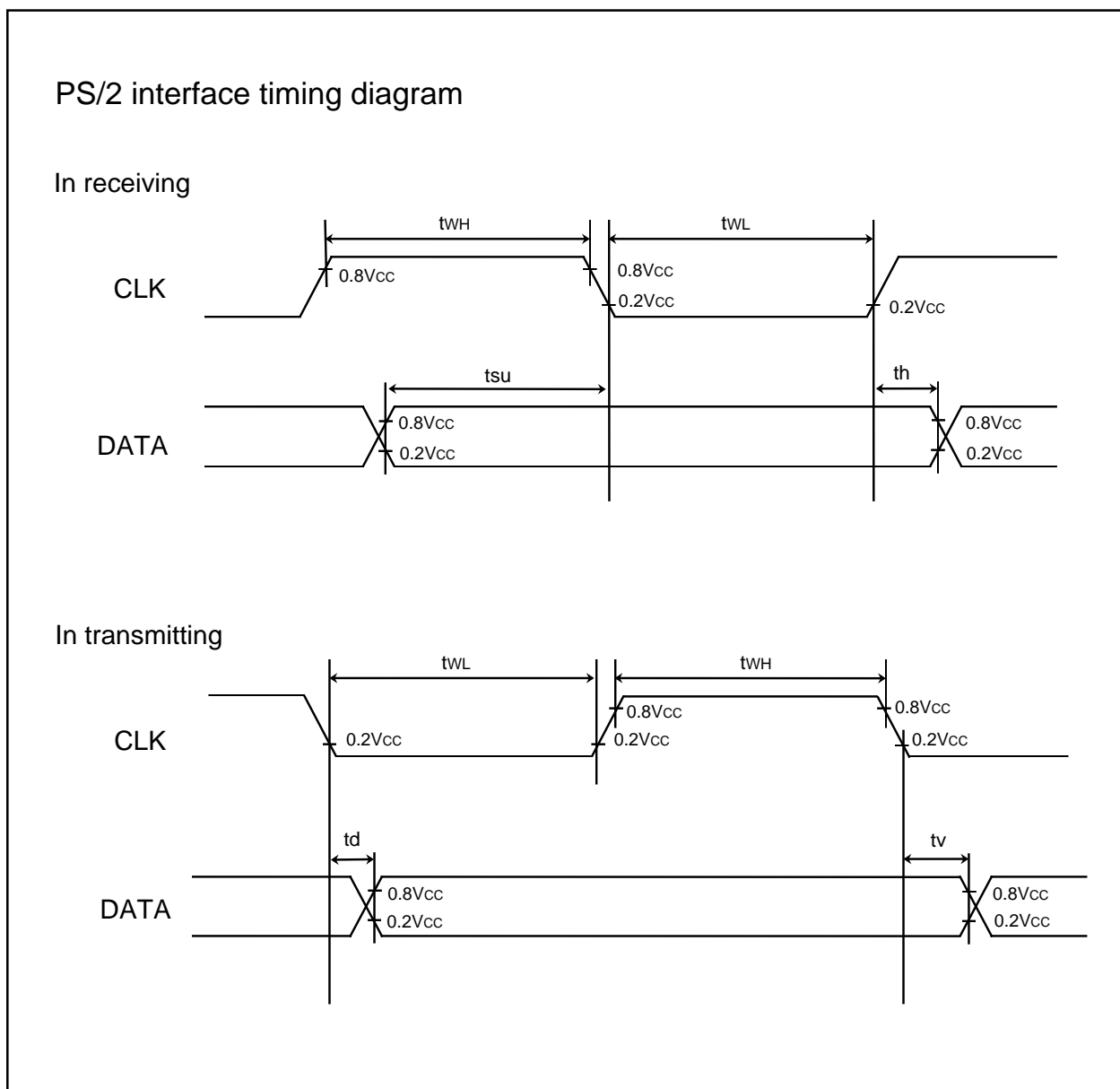

Fig.ZA-4 Timing diagram (3)

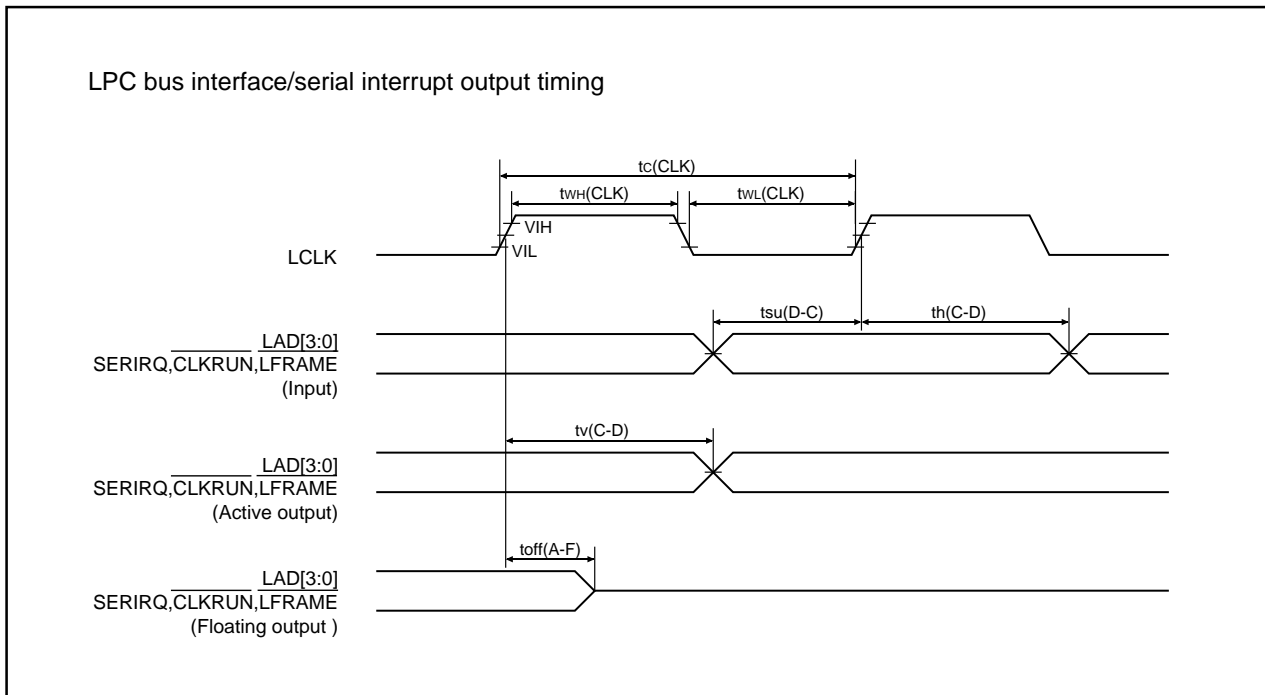

Fig.ZA-5 Timing diagram (4)

## Feature Outline

Table AB-1 shows the feature outline of M16C/6K7 (build-in NEW DINOR flash memory version).

**Table.AB-1 Feature outline of M16C/6K7 (build-in NEW DINOR flash memory version)**

Item		Feature
Power supply voltage		3.0-3.6V (f(X <sub>IN</sub> )=8MHz, 0 Wait)
Flash memory operation mode		3 modes (parallel I/O, standard serial I/O, CPU reprogram)
Erase block division	User ROM area	See Fig.AB-1
	Boot ROM area	1 division (4K bytes) (Note1)
Program method		2-byte unit
Erase method		Block erase
Program/ erase control method		Program/ erase controlled by s/w commands
Number of command		5 commands
Program/ erase count		100 times
ROM code protect		Support for parallel I/O and standard serial I/O modes

Note1: The control program for standard serial I/O mode is stored in boot ROM area when shipping from factory.  
The area can only be erased or programmed by parallel I/O mode.

### Flash Memory

The M16C/6K7 (build-in flash memory version) contains the NEW DINOR type flash memory, which is applied 1 power supplies  $V_{CC}=3.3V$  when using CPU reprogram or standard serial I/O mode. For the flash memory, 3 flash memory modes are available in which to read, program and erase. They are parallel I/O mode, standard serial I/O mode and CPU reprogram mode. For parallel I/O mode, a programmer is used. For standard serial I/O and CPU reprogram modes, the flash memory is manipulated by CPU. Each mode is detailed in the pages to follow.

Fig. AB-1 shows that flash memory is divided into several blocks. Erasing is in block unit.

In addition to the ordinary user ROM area there is a boot ROM area to store the control program for the CPU reprogram and standard serial I/O modes. The control program for standard serial I/O mode is stored in boot ROM area when shipping from factory. User can reprogram the program to suit its own application system. The area can only be erased or programmed by parallel I/O mode.

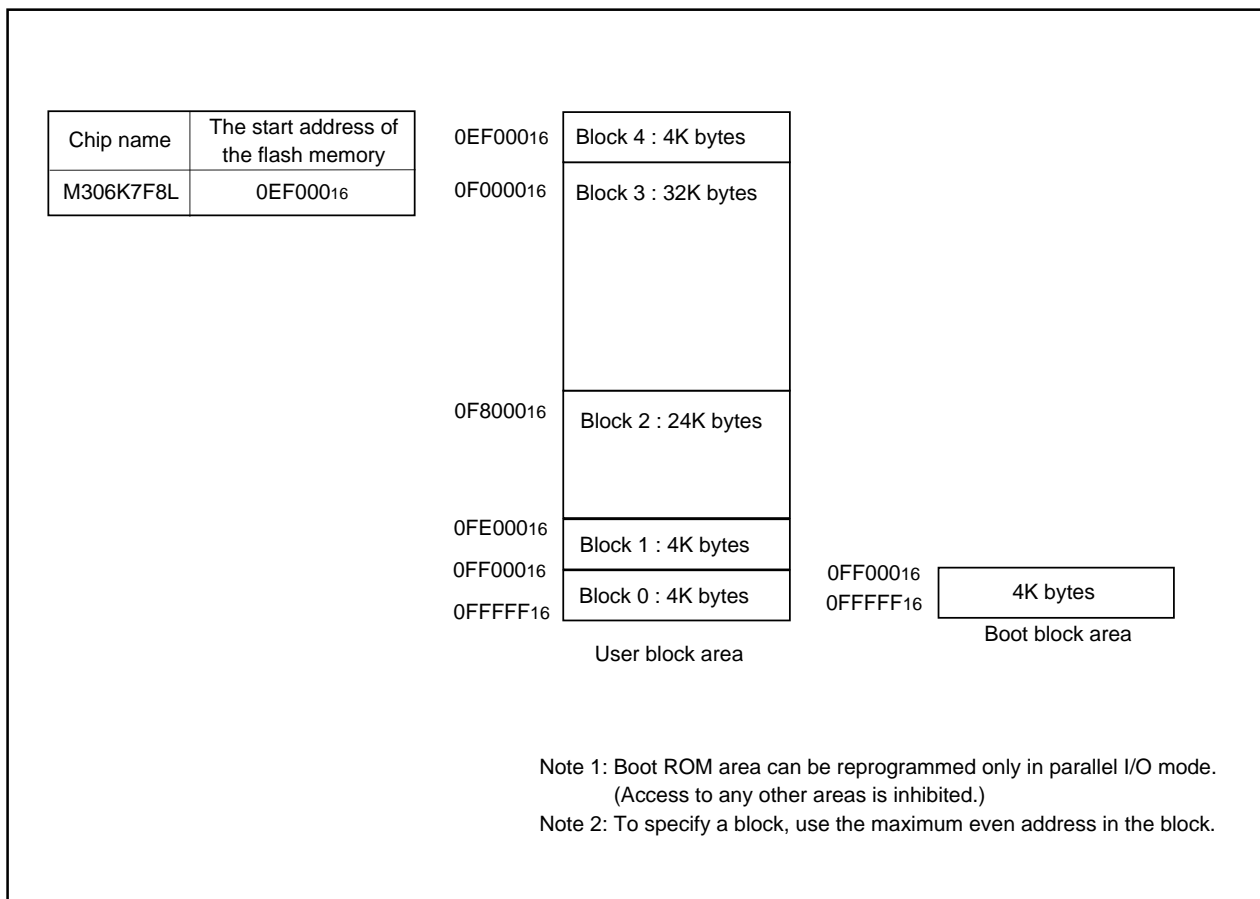

Fig.AB-1 Block diagram of flash memory version

### **CPU reprogram mode**

In CPU reprogram mode, the on-chip flash memory can be operated on (read, program or erase) under the control of CPU.

In CPU reprogram mode, only the user ROM area shown in Fig.AB-1 can be reprogrammed. The boot ROM area cannot be reprogrammed. Make sure the program and block erase commands are issued only for each block of the user ROM area.

The control program for CPU reprogram mode can be stored in either user ROM or boot ROM area. In CPU reprogram mode, because the flash memory cannot be read from CPU, the control program must be transferred to the RAM area before execution.

### **Microcomputer mode and Boot mode**

The control program for CPU reprogram mode must be written into the user ROM or boot ROM area in parallel I/O mode beforehand. (If the control program is written into the boot ROM area, the standard serial I/O mode becomes disable.)

See Fig.AB-1 for details about the boot ROM area.

Normal microcomputer mode is entered when reset with pulling "L" of M0. In this case, the CPU starts operating the control program in user ROM area.

If the microcomputer is reset with M0 being "H" and M1 being "L", the CPU starts operating the control program in boot ROM area. This mode is called as "boot" mode.

### **Block address**

Block address refers to the maximum even address of each block. The address is used in block erase command.

### Feature Outline (CPU reprogram mode)

In CPU reprogram mode, the CPU erases, programs and reads the on-chip flash memory as instructed by S/W commands. The reprogram control program must be transferred to the RAM area before it can be executed.

The CPU reprogram mode is accessed by writing "1" to the CPU reprogram select bit (bit 1 in address 03B716). S/W commands are accepted once the mode is accessed.

In CPU reprogram mode, the writing and reading of the commands and data should be in even address ("0" for byte address A0) in 16-bit unit, so the 8-bit unit S/W commands should be written in even address. Commands are ignored with odd address.

Use S/W commands to control flash memory programming and erasing. Whether the programming and erasing operation terminates correctly or in error can be verified by reading the status register.

Fig.BB-1 shows the flash control register.

Bit 0 is the RY/ $\overline{\text{BY}}$  status flag exclusively used to read the operating status of the flash memory. During programming and erasing operation, it is "0", otherwise it is "1".

Bit 1 is the CPU reprogram mode select bit. When the bit is set to "1", CPU reprogram mode is entered S/W commands then can be accessed. In CPU reprogram mode, the CPU cannot access the on-chip flash memory directly. Therefore, use the control program in RAM to write the bit to "1". To set the bit, it is necessary to write "0" and then write "1" in succession. The bit can be cleared to "0" by only writing the "0".

Bit 3 is the flash memory reset bit used to reset the control circuit of the on-chip flash memory. The bit is used when exiting the CPU reprogram mode and when flash memory access has failed. When the CPU reprogram mode select bit is "1", writing "1" to the bit resets the control circuit. To release the reset, it is necessary to set the bit to "0". If the control circuit is reset while erasing is in progress, the wait for 5 ms is needed so that the flash memory can restore to the normal operation.

Bit 5 of the flash control register 0 is the user ROM select bit. It is enabled only in boot mode. When the bit is set to "1", the accessed area is switched from boot ROM to user ROM. When CPU reprogram mode is entered in boot mode, please set this bit to "1". The bit is disabled when program starts in user ROM. Please write the bit with the program that is not located in on-chip flash memory area.

Fig.BB-2 shows a flowchart for the setting/ releasing the CPU reprogram mode.



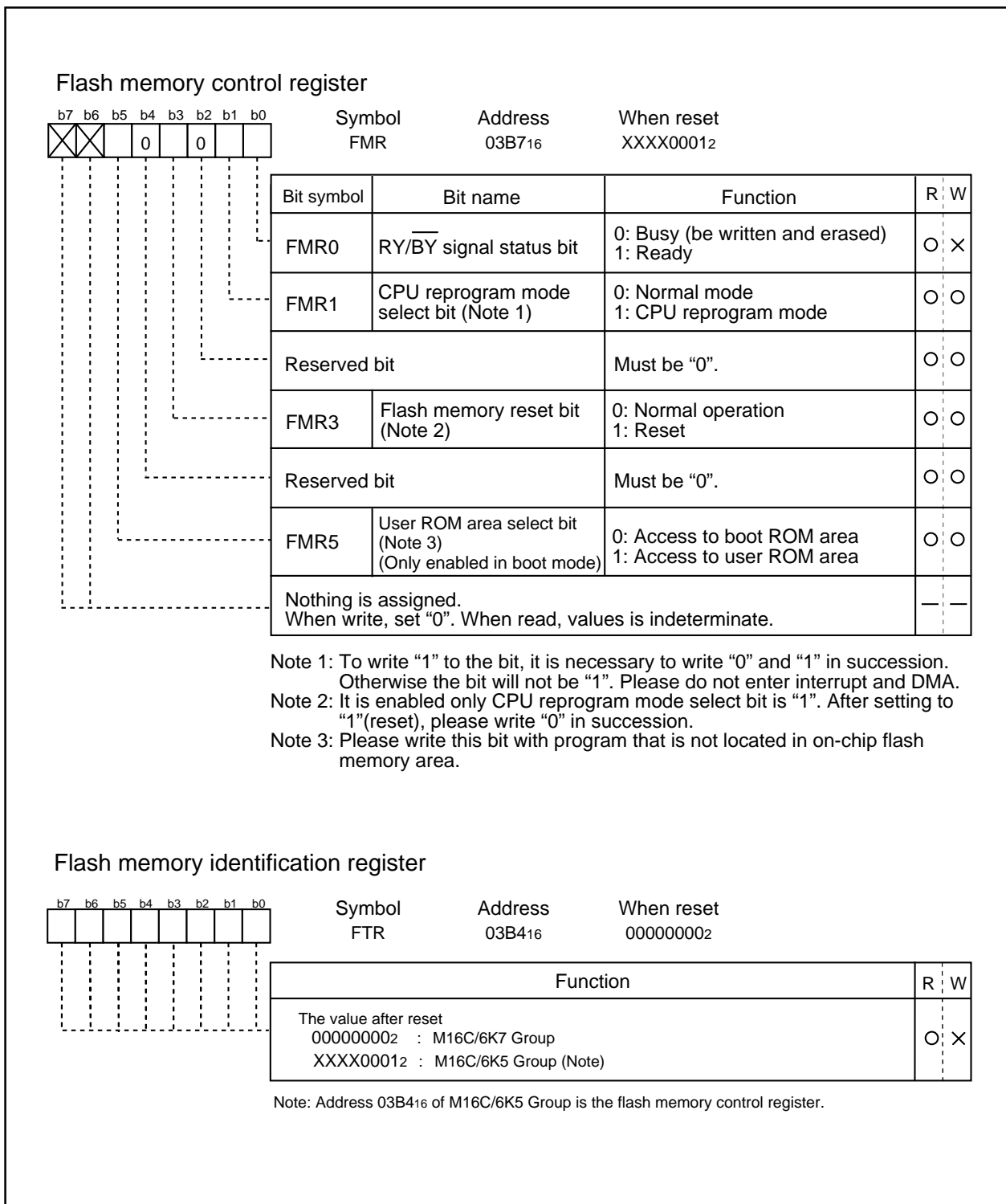

Fig.BB-1 The structure of flash memory control register and flash memory identification register

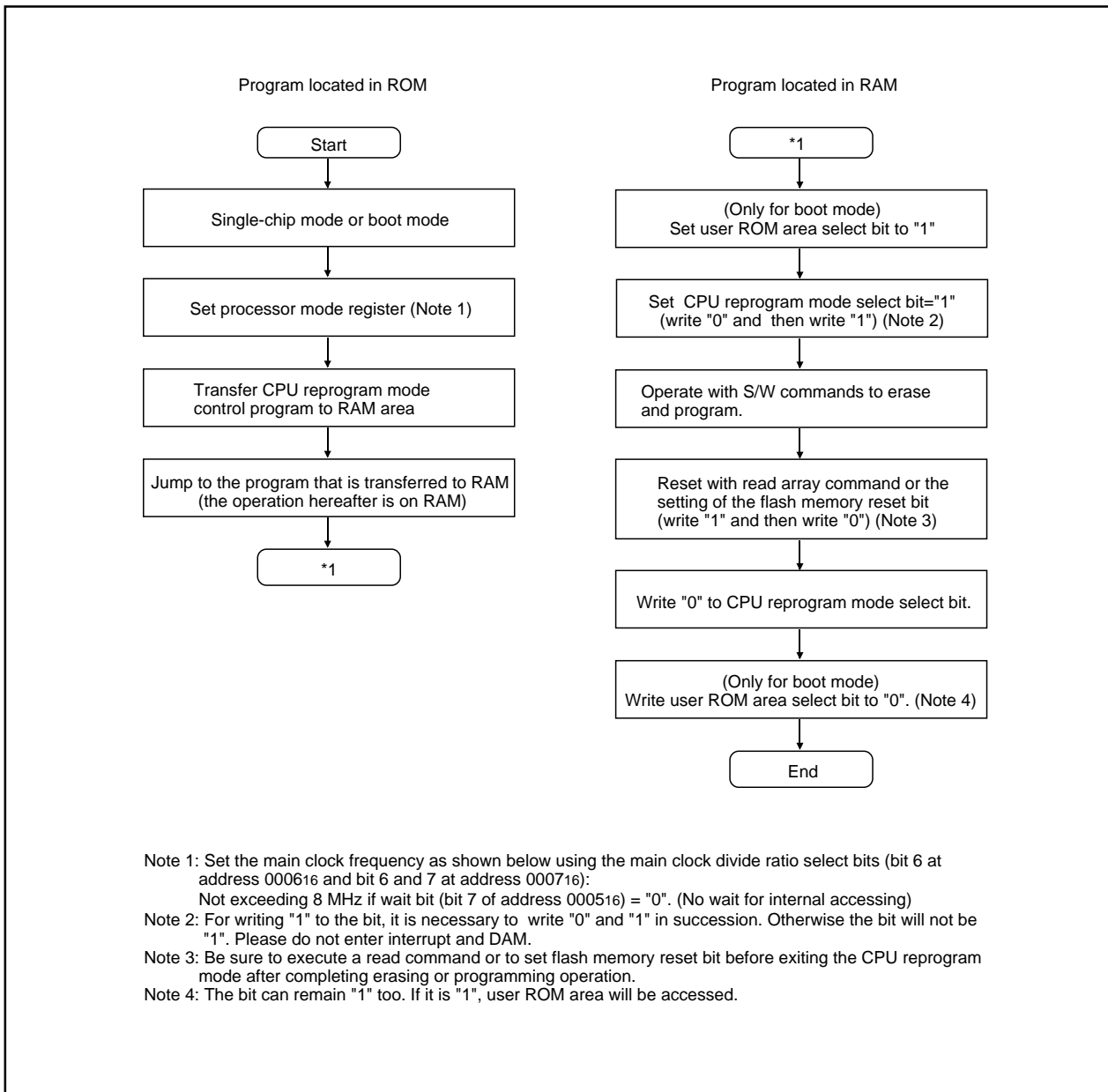

Fig.BB-2 CPU reprogram mode set/reset flowchart

### Precautions on CPU reprogram mode

Described below are the precautions to be observed in programming the flash memory in CPU reprogram mode.

#### (1) Operation speed

During CPU reprogram mode, set the main clock frequency as shown below using the main clock divide ratio select bits (bit 6 at address 0006<sub>16</sub> and bit 6 and 7 at address 0007<sub>16</sub>):

Not exceeding 8MHz if wait bit (bit 7 of address 0005<sub>16</sub>) = "0". (No wait for internal accessing)

#### (2) Instructions inhibited against use

The instructions listed below cannot be used during CPU reprogram mode because they refer to the internal data of the flash memory:

UND instruction, INTO instruction, JMPS instruction, JSRS instruction and BRK instruction

#### (3) Interrupts inhibited against use

The NMI, address match and WDC interrupts cannot be used during CPU reprogram mode because they refer to the internal data of the flash memory. If interrupts have their vectors in the variable vector table, they can be used by transferring the vector into the RAM area.

#### (4) Reset

The reset is always receivable.

#### (5) The reprogram in user ROM area

When CPU reprogram mode is entered and the block that the flash reprogram control program is located is being reprogramming, the block may not be reprogrammed correctly if the power supply is suddenly down. It is possible that the flash reprogram cannot be executed again in this case. Thus, it is recommended to use standard serial I/O mode and parallel I/O mode.

## Software commands

Table BB-1 lists the S/W commands available.

After setting the CPU reprogram mode select bit to "1", the S/W commands can be used to specify the erasing or programming operation. Note that when entering a S/W command, the upper byte (D15–D8) is ignored.

The content of each S/W command is explained below.

**Table BB-1 List of software commands (CPU reprogram mode)**

Command	Cycle number	The 1 <sup>st</sup> bus cycle			The 2 <sup>nd</sup> bus cycle		
		Mode	Address	Data (D15–D0)	Mode	Address	Data (D15–D0)
Read array	1	Write	X (Note 5)	FF <sub>16</sub>			
Read status register	2	Write	X	70 <sub>16</sub>	Read	X	SRD(Note 2)
Clear status register	1	Write	X	50 <sub>16</sub>			
Program	2	Write	X	40 <sub>16</sub>	Write	WA(Note 3)	WD(Note 3)
Block erase	2	Write	X	20 <sub>16</sub>	Write	BA(Note 4)	D0 <sub>16</sub>

Note 1: When a S/W command is input, the high-order byte of the data(D15–D8) is ignored.

Note 2: SRD = Status Register Data

Note 3: WA = Write Address, WD = Write Data

Note 4: BA = Block Address (the maximum even address of the block)

Note 5: "X" can be any even address in user ROM area.

### Read Array Command (FF<sub>16</sub>)

Issuing the command code "FF<sub>16</sub>" in the 1<sup>st</sup> bus cycle enters the read array mode. When an even address is issued in one of the bus cycle that follows, the content of the address is read out at the data bus (D15–D0), 16 bits at a time.

The read array mode is retained intact until another command is written.

### Read Status Register Command (70<sub>16</sub>)

When the command code "70<sub>16</sub>" is issued in the 1<sup>st</sup> bus cycle, the content of the status register is read out at the data bus (D7–D0) by a read in the 2<sup>nd</sup> bus cycle.

The status register is explained in the next section.

### Clear Status Register Command (50<sub>16</sub>)

The command is used to clear the bits SR4 and SR5 of the status register after they have been set. These bits indicate that operation has ended in error. To use this command, issue the command code "50<sub>16</sub>" in the 1<sup>st</sup> bus cycle.

**Program Command (4016)**

Program operation starts when the command code "4016" is issued in the 1<sup>st</sup> bus cycle. If the address and data are issued in the 2<sup>nd</sup> bus cycle, program operation (data programming and verification) will start.

Whether the program operation is completed can be conformed by reading the status register or the RY/B $\bar{Y}$  status flag. When the program starts, the read status register mode is accessed automatically and the content of the status register can be read on the data bus (D7–D0). The status register bit 7 (SR7) is set to "0" at the same time when the program operation starts and is returned to "1" upon the completion of the program operation. In this case, the read status register mode remains active until the Read Array Command (FF16) is issued.

The RY/B $\bar{Y}$  status flag is "0" during program operation and "1" when the program operation is completed same as the status register bit 7.

After the program, reading the status register can check the result. Refer to the section where the status register is detailed.

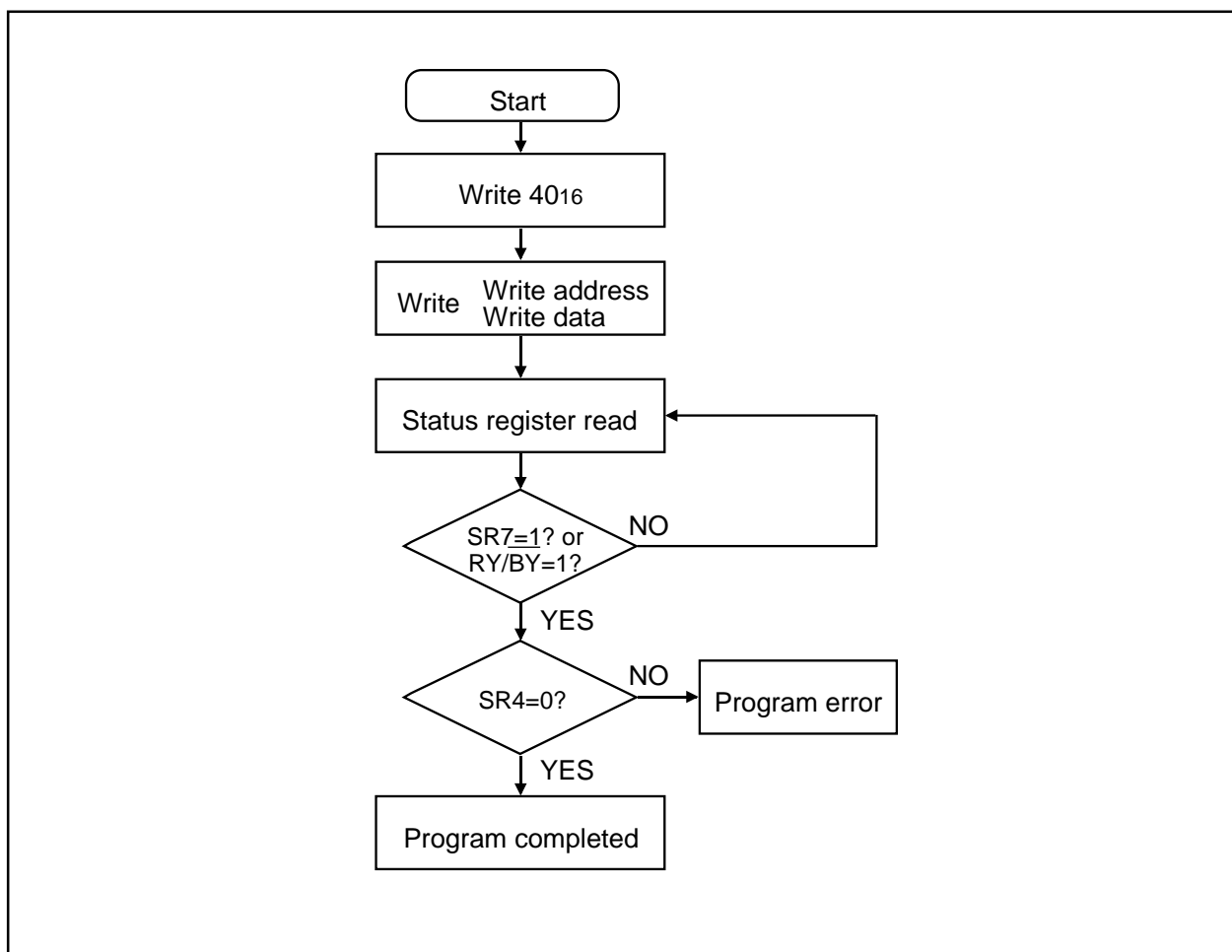

Fig.BB-3 Program flowchart

**Block Erase Command (20<sub>16</sub>/D0<sub>16</sub>)**

By issuing the command code "20<sub>16</sub>" in the 1<sup>st</sup> bus cycle and the conformation command code "D0<sub>16</sub>" and block address in the 2<sup>nd</sup> bus cycle, the erase operation specified by the block address starts (erase and erase verification).

Whether the block erase command is terminated can be conformed by reading the status register or the RY/ $\overline{\text{BY}}$  status flag. When the block erase operation starts, the read status register mode is accessed automatically and the content of the status register can be read out. The status register bit 7 (SR7) is set to "0" at the same time when the erase operation starts and is returned to "1" upon the completion of the erase operation. In this case, the read status register mode remains active until the Read Array Command (FF<sub>16</sub>) is written.

The RY/ $\overline{\text{BY}}$  status flag is "0" during erase operation and "1" when the erase operation is completed the same as the bit 7 of status register.

After the block erase, reading the status register can check the result. Refer to the section where the status register is detailed.

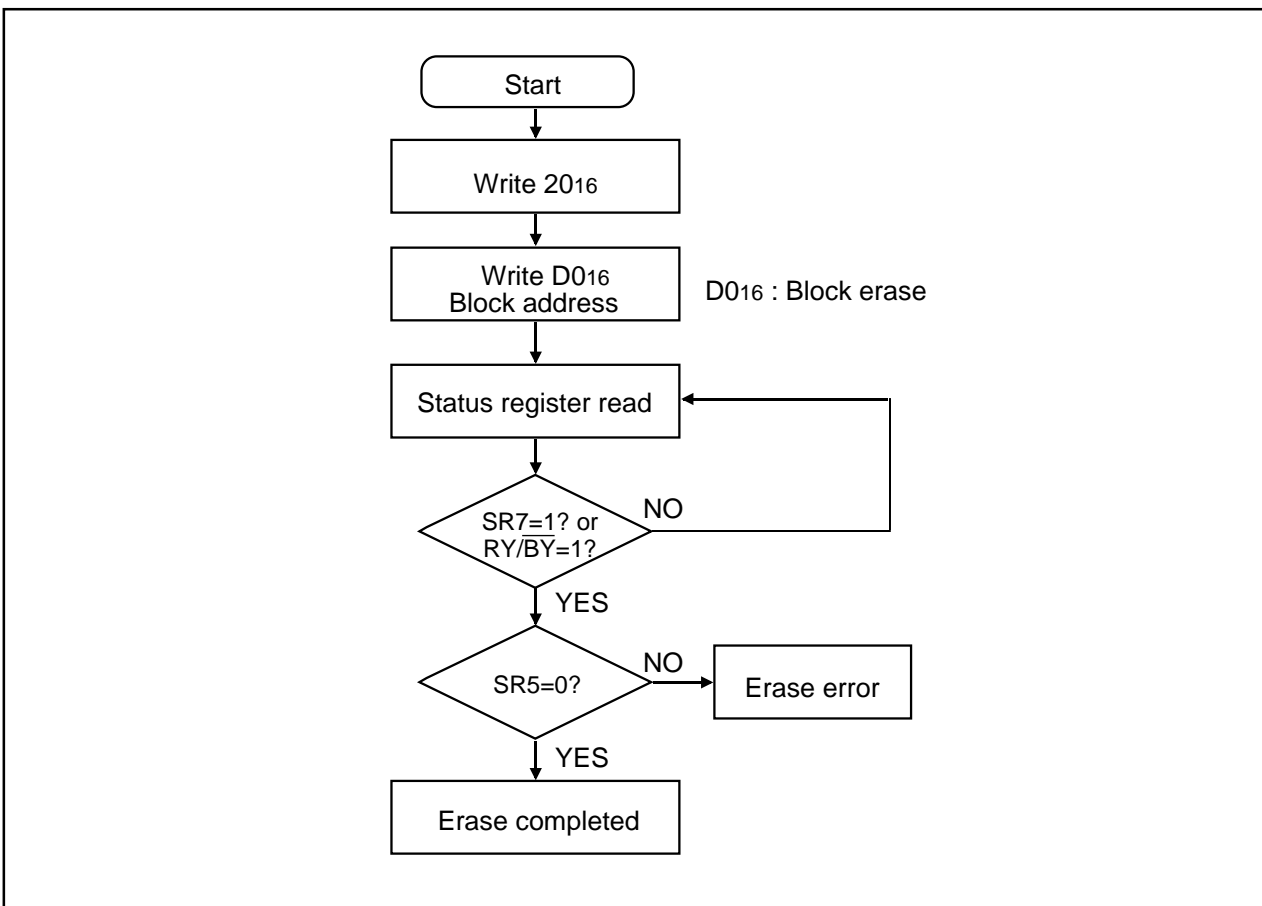

Fig.BB-4 Erase flowchart

## Status register

The status register shows the operation status of the flash memory and whether program and erase operations end successfully or not. It can be read in the following conditions.

- (1) By reading an arbitrary address from the user ROM area after issuing the read status register command (70<sub>16</sub>)
- (2) By reading an arbitrary address from the user ROM area in the period from the start of program or erase operation to the execution of read array command (FF<sub>16</sub>).

Table BB-2 shows the status register.

The status register can be cleared in the following condition.

- (1) By issuing the clear status register command (50<sub>16</sub>).
- (2) After reset, the status register is set to "80<sub>16</sub>".

Each bit of the register is shown below.

### Sequencer status (SR7)

After power-on, the sequencer status is set to "1" (ready).

The bit is set to "0" (busy) during program and erase operations and is set to "1" upon the completion of these operations.

### Erase status (SR5)

Erase status indicates the status of erase operation. When erase error occurs, it is set to "1".

The bit becomes "0" when it is cleared.

### Program status (SR4)

Program status indicates the status of program operation. When program error occurs, it is set to "1".

The bit becomes "0" when it is cleared.

If "1" is set to SR5 or SR4, the program and block erase operations are not accepted. Before execution of these commands, it is necessary to execute the clear status register command (50<sub>16</sub>) to clear the status register.

If any S/W commands are not correct, both the SR5 and SR4 are set to "1".

**Table BB-2 Definition of each bit of status register**

Each bit of SRD	Status name	Definition	
		"1"	"0"
SR7 (bit7)	Sequencer status	Ready	Busy
SR6 (bit6)	Reserved	-	-
SR5 (bit5)	Erase status	Terminated in error	Terminated normally
SR4 (bit4)	Program status	Terminated in error	Terminated normally
SR3 (bit3)	Reserved	-	-
SR2 (bit2)	Reserved	-	-
SR1 (bit1)	Reserved	-	-
SR0 (bit0)	Reserved	-	-

**Full status check**

By performing full status check, the execution result of erase and program operations can be known. Fig.BB-5 shows the full status check flowchart and the method to deal with the error.

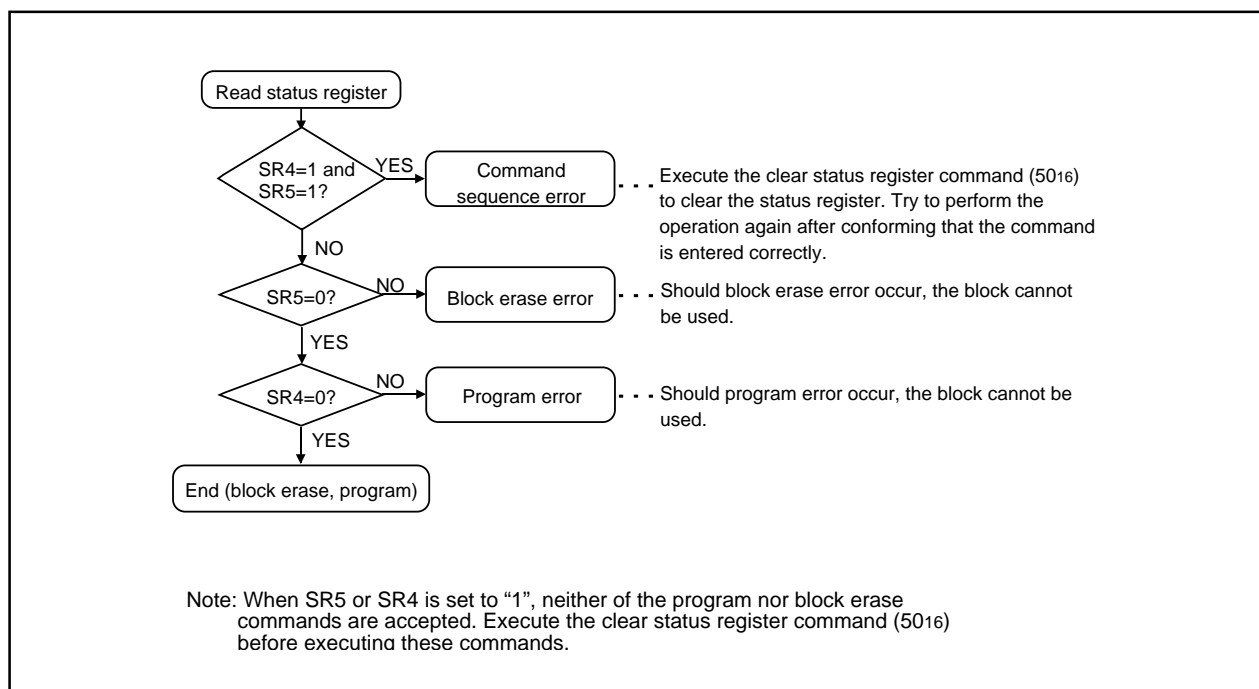

**Fig.BB-5 Full status check flowchart and the method to deal with errors**



## Functions to inhibit rewriting to the on-chip flash memory

To prevent flash memory from being miss-read or miss-written, ROM code protect function for parallel I/O mode and ID code check function for standard serial mode are introduced.

### ROM code protect function

ROM code protect function can inhibit readout from or modification to the flash memory by setting the content in ROM code protect control address (0FFFFFF<sub>16</sub>) for parallel I/O mode. Fig.BB-6 shows the content of ROM code protect control address (0FFFFFF<sub>16</sub>). (The address exists in user ROM area.)

If one of the pair of ROM code protect bits is set to "0", ROM code protect is turned on, so that the flash memory is protected against the readout or modification. ROM code protect is implemented in two levels. If level 2 is selected, the flash memory is protected even against readout by a shipment inspection LSI tester, etc. When both level 1 and level 2 are set, level 2 will be selected.

If both of the two ROM code protect reset bits are set to "00", ROM code protect is turned off, so that the flash memory can be read out or modified. Once ROM code protect is turned on, the ROM code protect reset bits cannot be modified in parallel I/O mode. Use the serial mode or other to rewrite these two bits.

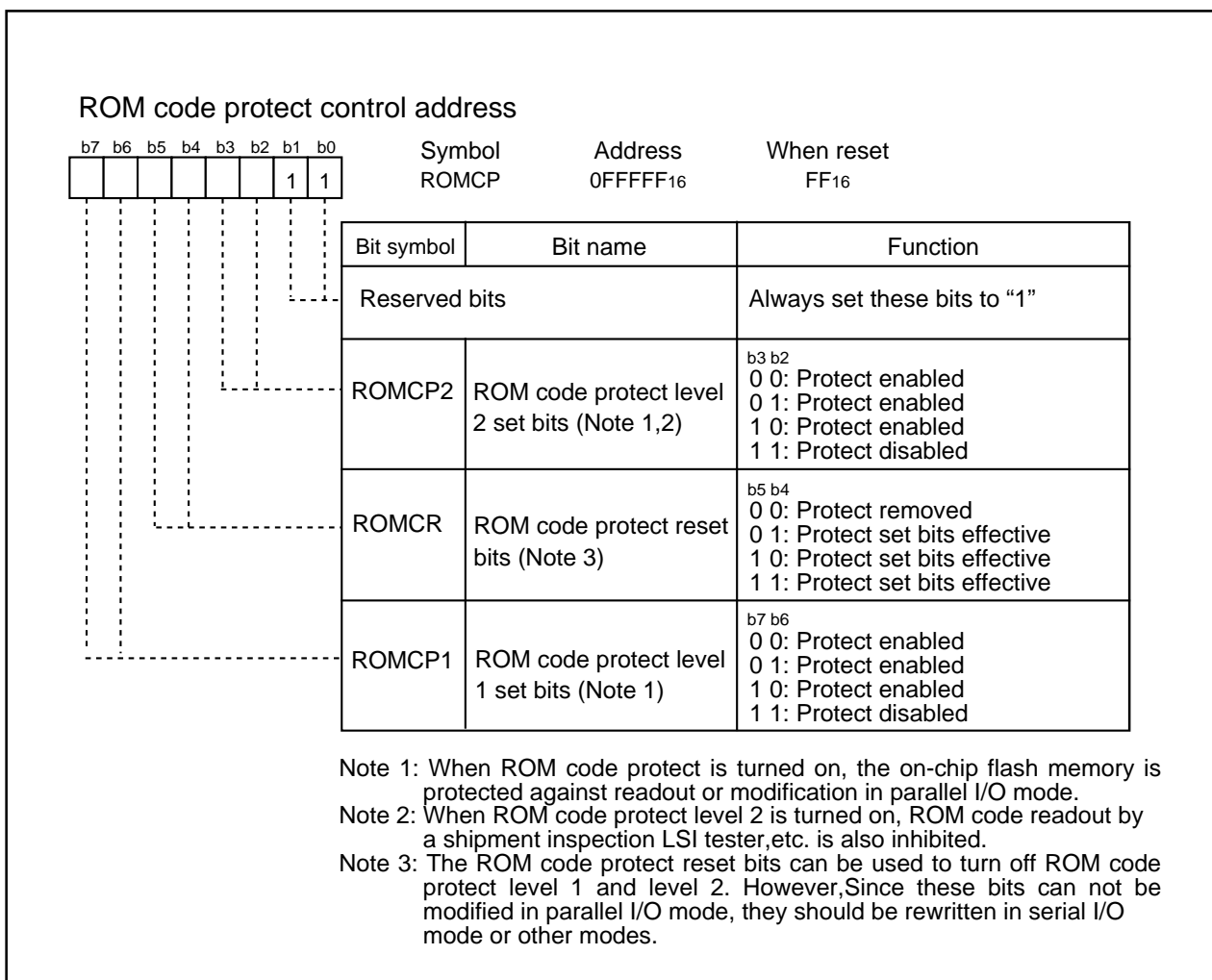

Fig.BB-6 ROM code protect control address

### ID code check function

The function is used in standard serial I/O mode. If the flash memory is not blank, the ID code sent from serial burner is compared with that inside flash memory to check the agreement. If the ID codes do not match, the commands from serial burner are not accepted. Each ID code consists of 8-bit data, the areas of which, beginning from the 1<sup>st</sup> byte, are 0FFFDF<sub>16</sub>, 0FFFE3<sub>16</sub>, 0FFFEB<sub>16</sub>, 0FFFEF<sub>16</sub>, 0FFFF3<sub>16</sub>, 0FFFF7<sub>16</sub>, 0FFFFB<sub>16</sub>. Write a program with the ID code at these addresses to the flash memory.

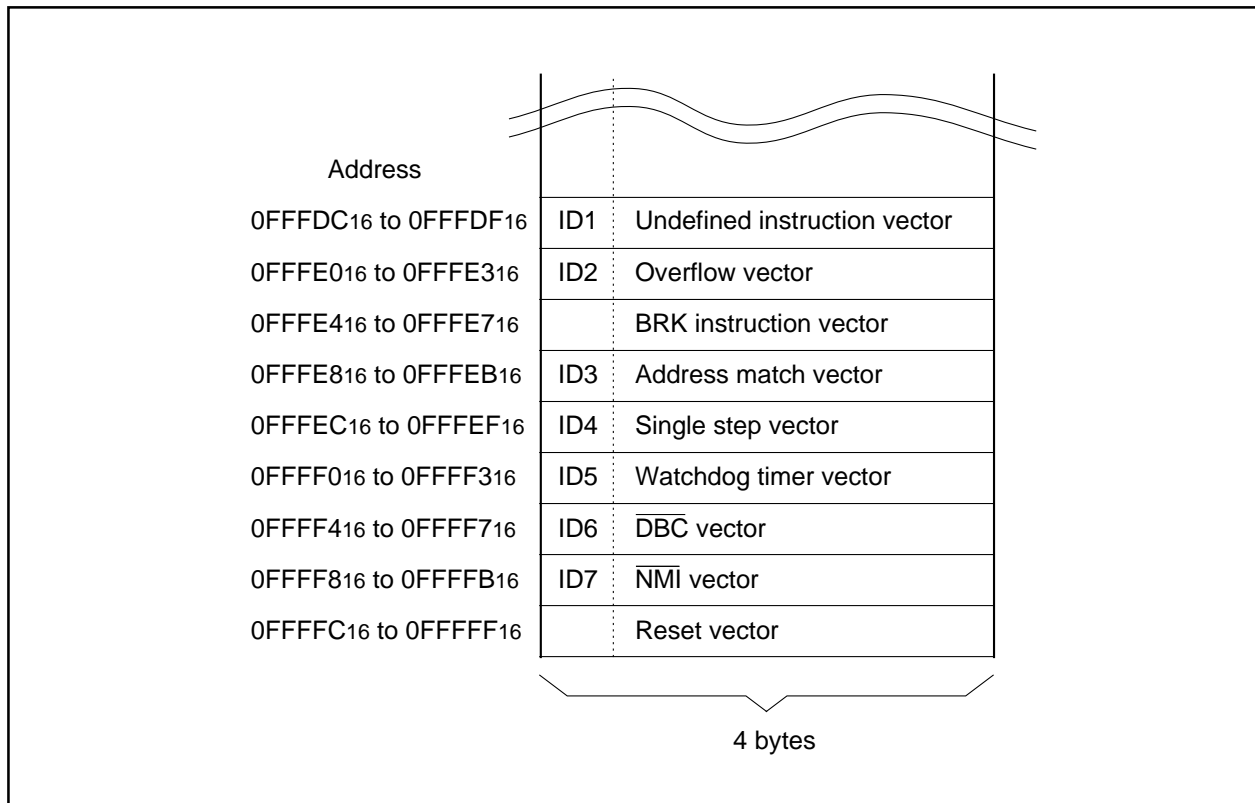

Fig.BB-7 ROM ID code addresses

### Parallel I/O mode

Parallel I/O mode is to input and output the software command, address and data in parallel to access the on-chip flash memory (read, program, erase etc.).

Please use the specific device (programmer) supported for M16C/6K7 Group. Referring to the guideline etc. of each device manufacture for the usage.

### User ROM area and boot ROM area

In parallel I/O mode, both user ROM area and boot ROM area showed in Fig.AB-1 can be reprogrammed. The access method to both areas is the same.

The size of boot ROM area is 4K bytes. The addresses are allocated in  $0FF000_{16}$ –  $0FFFFFF_{16}$ . Make sure program and block erase operations are always performed within this address range. (Access to any location outside this address range is prohibited.)

In the boot ROM area, erase block operation is applied to only one 4K bytes block. The boot ROM area has had a standard serial I/O mode control program stored in it when shipped from Mitsubishi factory. Therefore, if the standard serial I/O mode is used, the rewriting to the boot ROM area is not necessary.

Table EE-1 Pin function (Flash memory standard serial I/O mode)

Pin name	Name	I/O	
Vcc, Vss	Power supply		Apply $3.3 \pm 0.3V$ to Vcc, apply 0V to Vss
M0	M0	I	Connect to Vcc
RESET	Reset input	I	Reset input pin. While reset is "L", 20 cycles or more clocks input to XIN pin are needed.
XIN	Clock input	I	Connect a ceramic resonator or crystal oscillator between XIN and XOUT. If external clock is used, input it to XIN pin and open the XOUT pin.
XOUT	Clock output	O	
M1	M1	I	Connect to Vss
AVcc, AVss	Analog power supply		Connect AVss to Vss, AVcc to Vcc
VREF	Reference voltage	I	The input pin of reference voltage of AD converter
P00–P07	Input port P0	I	Input "H", "L" or open
P10–P17	Input port P1	I	Input "H", "L" or open
P20–P27	Input port P2	I	Input "H", "L" or open
P30–P37	Input port P3	I	Input "H", "L" or open
P40–P47	Input port P4	I	Input "H", "L" or open
P50–P57	Input port P5	I	Input "H", "L" or open
P60–P63	Input port P6	I	Input "H", "L" or open
P64	BUSY output	O	The output pin of BUSY signal
P65	SCLK input	I	The input pin of serial clock
P66	RxD input	I	The input pin if serial data
P67	TxD input	O	The output pin of serial data
P70–P77	Input port P7	I	Input "H", "L" or open
P80–P84 P86,P87	Input port P8	I	Input "H", "L" or open
P85	NMI input	I	Connect to Vcc
P90–P97	Input port P9	I	The input pin of serial data
P100–P107	Input port P10	I	The input pin of serial data
P110–P117	Input port P11	I	The input pin of serial data
P120–P127	Input port P12	I	The input pin of serial data
P130–P137	Input port P13	I	The input pin of serial data
P140–P147	Input port P14	I	The input pin of serial data
P150–P157	Input port P15	I	The input pin of serial data
P160,P161	Input port P16	I	The input pin of serial data

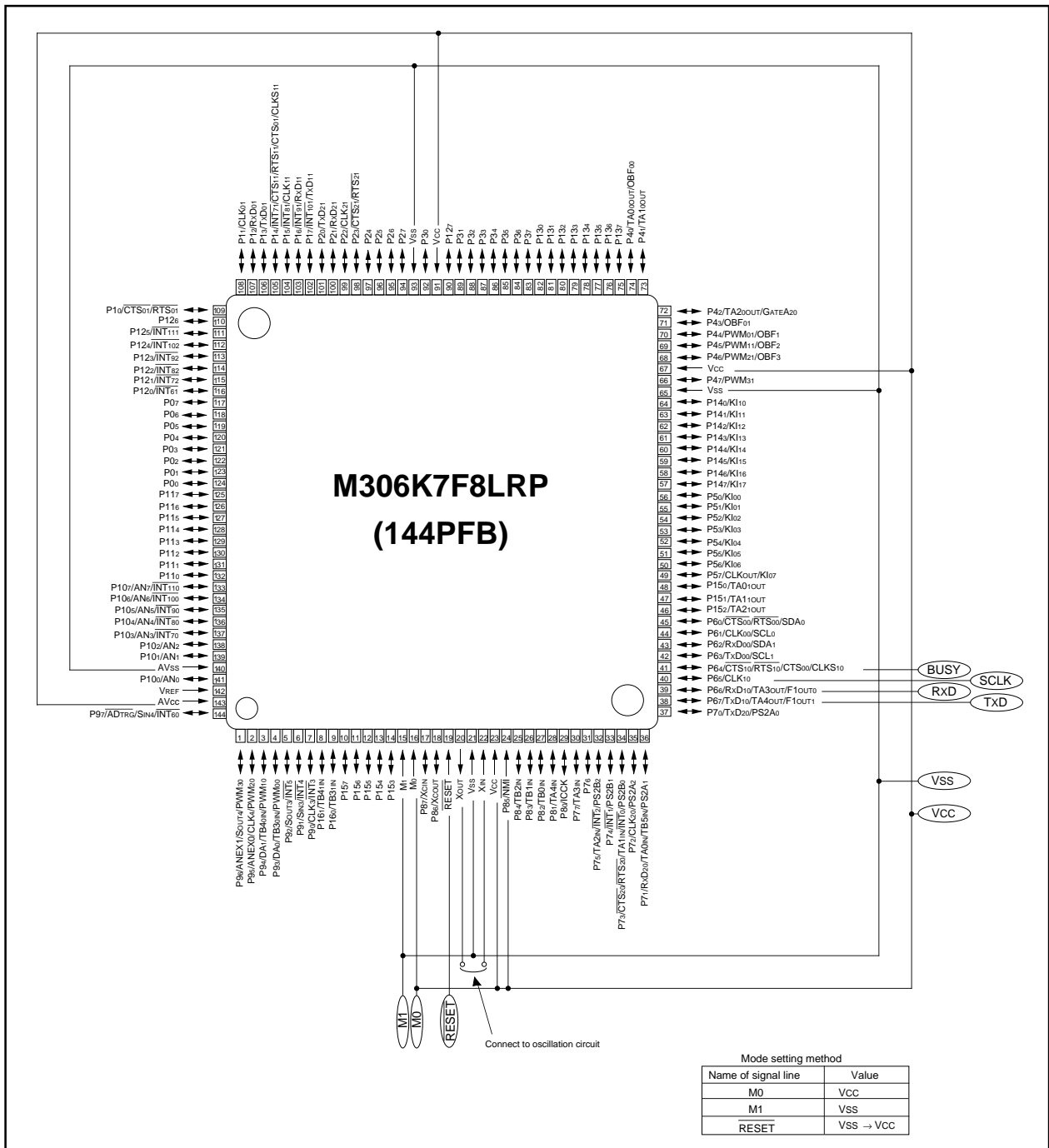

Fig.EE-1 Pin connections for serial I/O mode

### Standard serial I/O mode

The standard serial I/O mode inputs and outputs the S/W commands, addresses and data needed to operate (read, program, erase etc.) the on-chip flash memory with a dedicated serial programmer.

Different from parallel I/O mode, in standard serial mode, CPU controls the flash memory reprogramming (uses the CPU reprogram mode) and the input of serial reprogram data etc. The standard serial I/O mode is started by connecting M0 to "H", M1 to "L" with the release of reset. (To connect M0 to "L" in normal microcomputer mode.)

This control program is written in boot ROM area when the product is shipped from Mitsubishi factory. Make sure that the standard serial I/O mode cannot be used if boot ROM area is written in parallel I/O mode. Fig EE-1 shows the pin connections for standard serial I/O mode. The input and output of serial data are processed in CLK10, RxD10, TxD10, RTS10 (BUSY) 4 pins of the UART1.

The CLK10 is clock input pin, which clock is input externally. The TxD10 is CMOS output pin. The RTS10 (BUSY) pin outputs "L" when ready for reception and outputs "H" when reception starts. The serial data are transferred in 8-bit unit.

In standard serial I/O mode, only the user ROM area shown in Fig.AB-1 can be reprogrammed. Boot ROM area cannot be reprogrammed.

In the standard serial I/O mode, a 7-byte ID code is used. If the flash memory is not blank, commands sent from programmer are not accepted unless the ID code matches.

**Outline (standard serial I/O mode)**

In standard serial I/O mode, S/W commands, addresses, and data etc. are input and output with the peripheral device (serial programmer) using 4-wire clock-synchronized serial I/O (UART1). In reception, S/W commands, addresses and program data are read from RxD<sub>10</sub> pin synchronized with the rising edge of the transfer clock that is input to the CLK<sub>10</sub> pin. In transmission, the read data and status are output to TxD<sub>10</sub> pin synchronized with the falling edge of the transfer clock.

The TxD<sub>10</sub> is CMOS output pin. Transfer is in 8-bit unit with LSB first.

During transmission, reception, erasing and programming, the RTS<sub>10</sub> (BUSY) pin is "H". Accordingly, always start the next transfer after the RTS<sub>10</sub> (BUSY) pin becomes "L".

The read after the input of S/W commands can get memory data and status register. Reading the status register can check the flash memory operation status, the normal/error end of erasing or programming operation. The following are the explanation of S/W commands, status register etc.

## S/W commands

Table EE-2 lists the S/W commands. In standard serial I/O mode, the S/W commands, which transferred from RxD pin, control of erase, program and read etc. The S/W commands in standard serial I/O mode are similar with that in parallel I/O mode. ID check function, download function, version information output function, boot ROM area output function and read check data, 5 commands are added.

**Table EE-2 The list of S/W commands (standard serial I/O mode)**

	Control command	1 <sup>st</sup> byte transfer	2 <sup>nd</sup> byte	3 <sup>rd</sup> byte	4 <sup>th</sup> byte	5 <sup>th</sup> byte	6 <sup>th</sup> byte	–	If ID unmatched
1	Page read	FF <sub>16</sub>	Address (middle)	Address (high)	Data output	Data output	Data output	259 <sup>th</sup> byte data output	Not acceptable
2	Page program	41 <sub>16</sub>	Address (middle)	Address (high)	Data input	Data input	Data input	259 <sup>th</sup> byte data input	Not acceptable
3	Block erase	20 <sub>16</sub>	Address (middle)	Address (high)	D0 <sub>16</sub>				Not acceptable
4	Read status register	70 <sub>16</sub>	SRD output	SRD1 output					Acceptable
5	Clear status register	50 <sub>16</sub>							Not acceptable
6	ID check function	F5 <sub>16</sub>	Address (low)	Address (middle)	Address (high)	ID size	ID1	–ID7	Acceptable
7	Download function	FA <sub>16</sub>	Address (low)	Address (high)	Check sum	Data input	No. of times required	–ID7	Not acceptable
8	Version information output function	FB <sub>16</sub>	Version data output	Version data output	Version data output	Version data output	Version data output	–9 <sup>th</sup> byte Version data output	Acceptable
9	Boot ROM area output function	FC <sub>16</sub>	Address (middle)	Address (high)	Data output	Data output	Data output	–259 <sup>th</sup> byte data output	Not acceptable
10	Read check data	FD <sub>16</sub>	Check data (low)	Check data (high)					Not acceptable

Note 1: Shading indicates transfer from flash memory on chip microcomputer to serial programmer.

The else indicates transfer from serial programmer to flash memory on chip microcomputer.

Note 2: SRD means status register data. SRD1 means status register 1 data.

Note 3: All commands are acceptable if the flash memory is blank.



**The following are the descriptions of S/W commands**

**Page read command**

The command reads the specified page (256 bytes) of the flash memory sequentially one byte at a time.

Execute the page read command as following:

- (1) Transfer the "FF16" command code in the 1<sup>st</sup> byte.
- (2) Transfer addresses A8– A15 and A16– A23 in the 2<sup>nd</sup> and 3<sup>rd</sup> byte respectively.
- (3) From the 4<sup>th</sup> byte onward, data (D7–D0) of the page specified by the address (A23–A8) will be output sequentially from the smallest address sync with the falling edge of the clock.

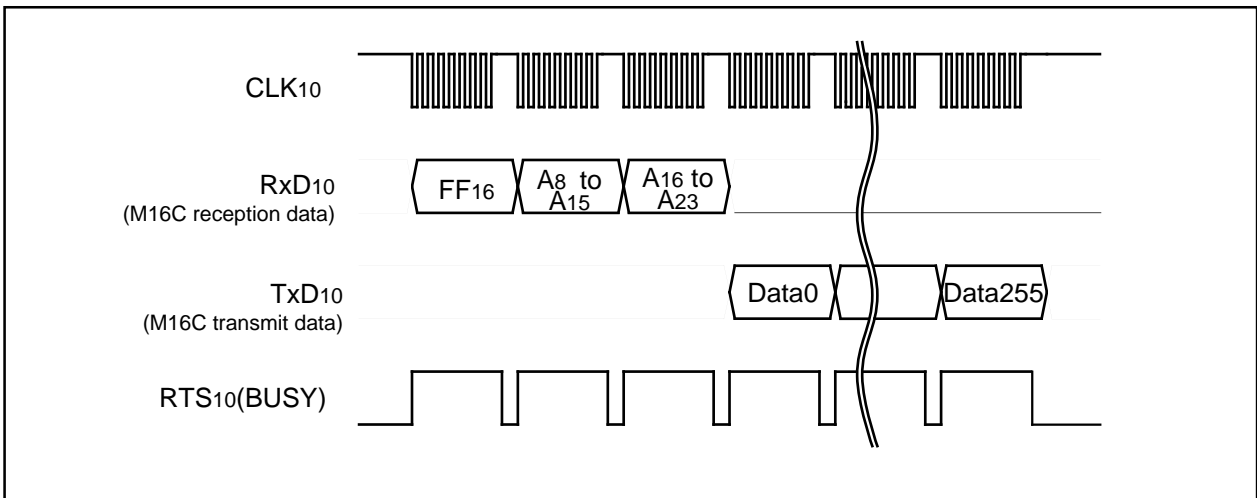

**Fig.EE-2 Timing of page read**

**Read status register command**

The command is for reading status information. When command code "7016" is sent in the 1<sup>st</sup> byte, the contents of status register (SRD) and status register 1 (SRD1) will be output in the 2<sup>nd</sup> and 3<sup>rd</sup> byte respectively sync with the falling edge of the clock.

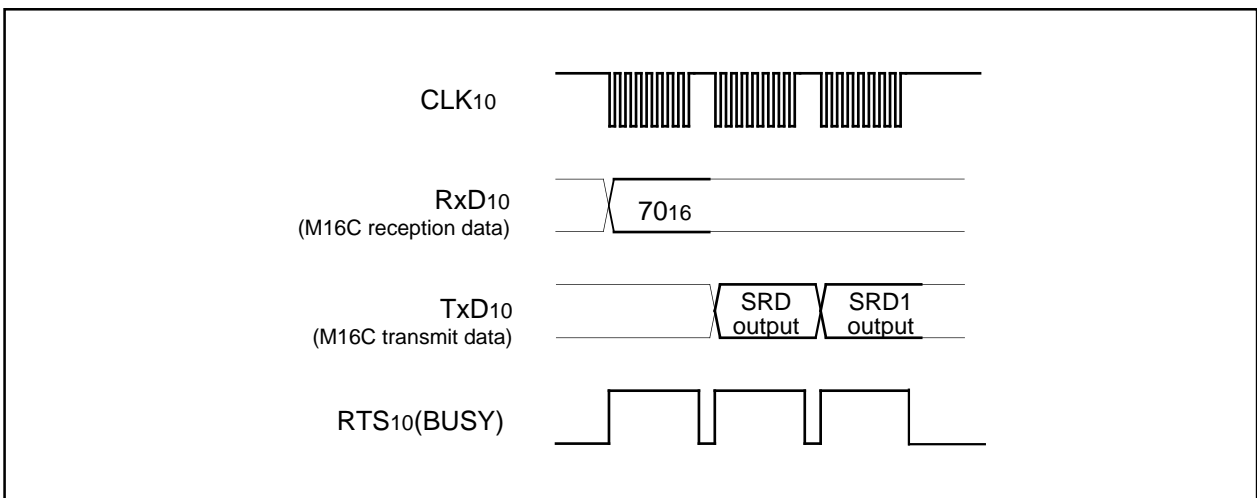

**Fig.EE-3 Timing of read status register**

**Clear status register command**

The command clears the bits (SR4–SR5), which are set when operation ended in error. When command code “50<sub>16</sub>” is sent in the 1<sup>st</sup> byte, the aforementioned bits are cleared. When the clear status register operation ends, the RTS<sub>10</sub> (BUSY) signal changes from “H” to “L”.

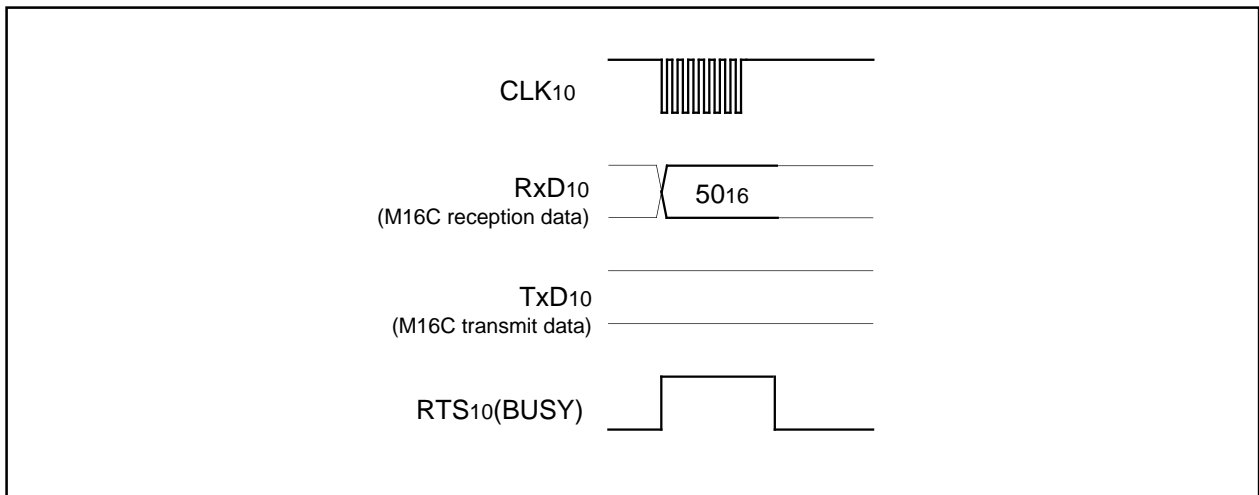

Fig.EE-4 Timing of clear status register

**Page program command**

The command programs the specified page (256 bytes) of flash memory sequentially one byte a time. Execute the command as follows:

- (1) Transfer the command code “41<sub>16</sub>” in the 1<sup>st</sup> byte.
- (2) Transfer addresses A<sub>15</sub>–A<sub>8</sub> and A<sub>23</sub>–A<sub>16</sub> in the 2<sup>nd</sup> and 3<sup>rd</sup> bytes respectively.
- (3) From the 4<sup>th</sup> byte onward, after inputting 256 bytes program data (A<sub>7</sub>–A<sub>0</sub>) from the smallest address of the specified page, the page program operation will be executed automatically.

When the reception for the next 256 bytes is setup, the RTS<sub>10</sub> (BUSY) signal changes from “H” to “L”.

The result of the page program can be known by reading the status register. For more detail, see the section on the status register.

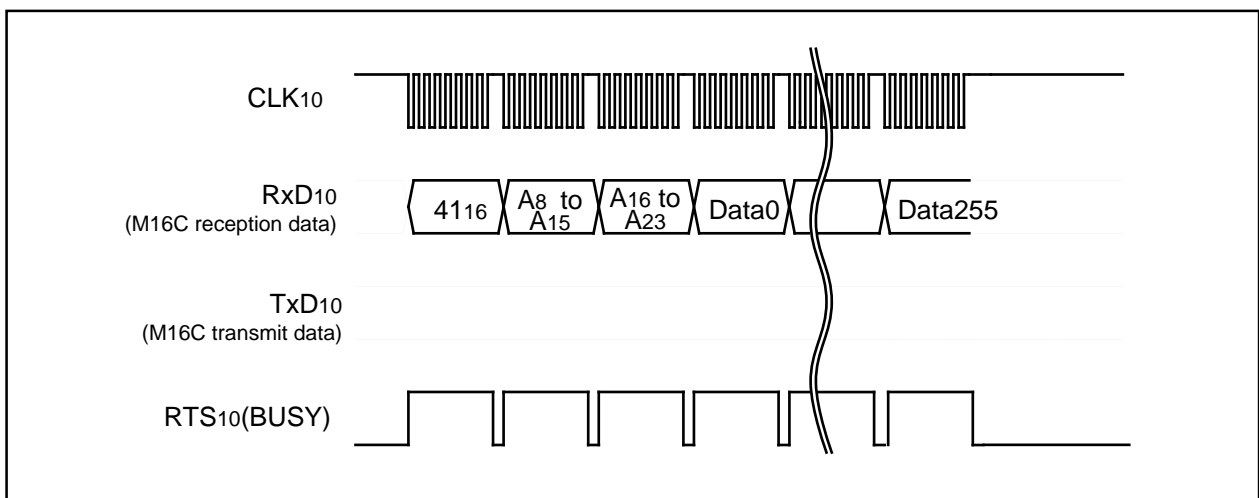

Fig.EE-5 Timing of page program

**Block erase command**

The command erases the data in the specified block. Execute the command as follows:

- (1) Transfer the command code "2016" in the 1<sup>st</sup> byte.
- (2) Transfer addresses A15–A8 and A23–A16 in the 2<sup>nd</sup> and 3<sup>rd</sup> bytes respectively.
- (3) After transferring the verify command code "D016" in the 4<sup>th</sup> byte, the erase operation starts for the specified block of the flash memory. Issue the biggest address of the specified block to A23–A8.

After the completion of block erase, the RTS<sub>10</sub> (BUSY) signal changes from "H" to "L". The result of the block erase can be known by reading the status register. For more detail, see the section on the status register.

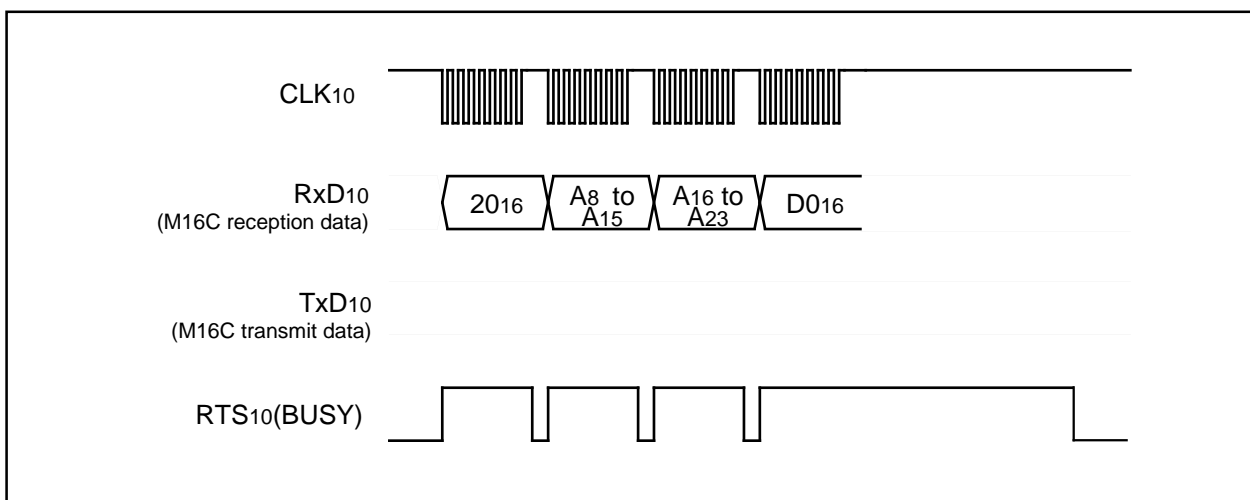

**Fig.EE-6 Timing of block erase**

**Download function**

The command downloads an execution program to RAM. Execute the command as follows:

- (1) Transfer the command code "FA16" in the 1<sup>st</sup> byte.
- (2) Transfer the program size in the 2<sup>nd</sup> and 3<sup>rd</sup> bytes.
- (3) Transfer the checksum in the 4<sup>th</sup> byte. Check sum is calculated from all transferred data from the 5<sup>th</sup> byte onward.
- (4) The execution program is transferred from 5<sup>th</sup> byte onward.

After the entire program data have been transferred, the downloaded execution program will be executed if the checksum matches.

The program size allowed to transfer varies according to the size of on-chip RAM.

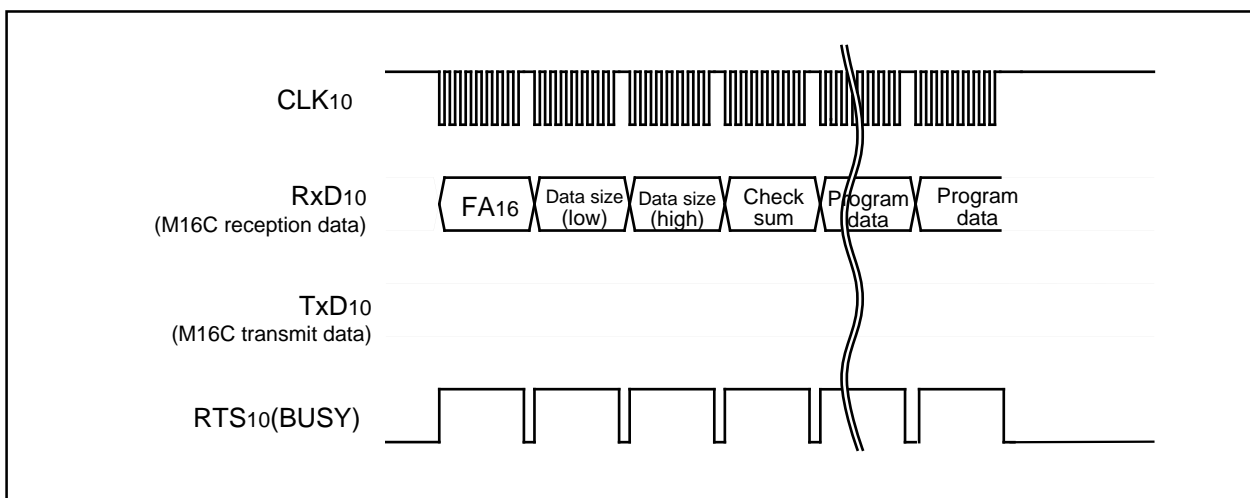

**Fig.EE-7 Timing of download function**

**Version information output function**

The version information of the control program stored in boot ROM area can be output by the function.

Execute the command as follows:

- (1) Transfer the command code "FB16" in the 1<sup>st</sup> byte.
- (2) From the 2<sup>nd</sup> byte onward, the version information will be output. The information is composed of 8 ASCII character code.

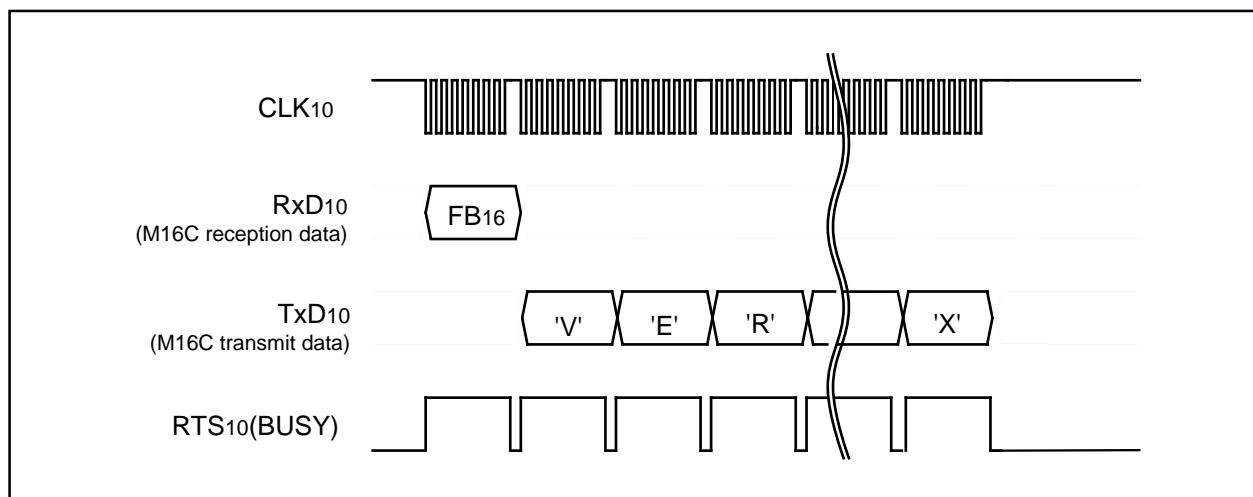

**Fig.EE-8 Timing of version information output function**

**Boot ROM area output function**

The control program stored in boot ROM area can be read out in page (256 bytes) unit by the function.

Execute the command as follows:

- (1) Transfer the command code "FC16" in the 1<sup>st</sup> byte.
- (2) Transfer addresses A15–A8 and A23–A16 in the 2<sup>nd</sup> and 3<sup>rd</sup> bytes respectively.

From the 4<sup>th</sup> byte onward, the data (D7–D0) specified in page (256 bytes) address A23–A8 will be output sequentially from the smallest address in sync with the rising edge of the clock.

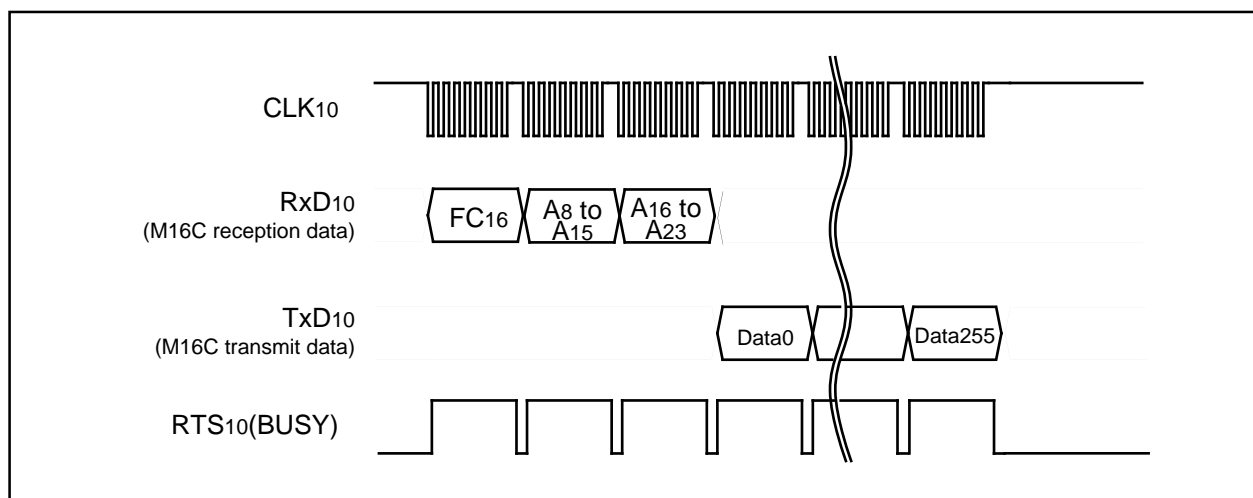
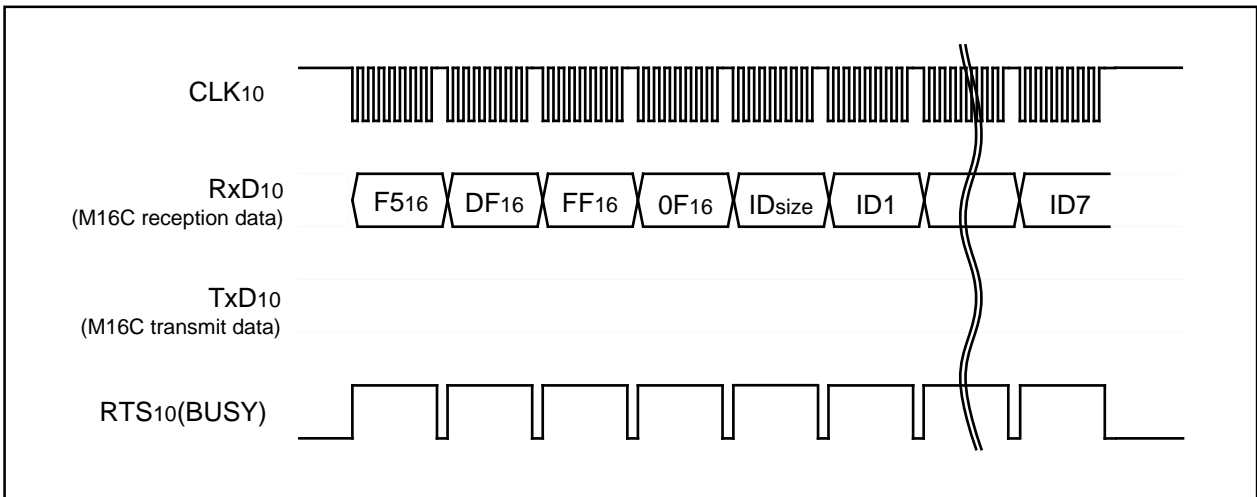

**Fig.EE-9 Timing of boot ROM area output function**

**ID check function**

The command checks the ID code. Execute the command as follows:

- (1) Transfer the command code "F5<sub>16</sub>" in the 1<sup>st</sup> byte.
- (2) Transfer addresses A7–A0, A15–A8 and A23–A16 of 1<sup>st</sup> ID code (ID1) in the 2<sup>nd</sup>, 3<sup>rd</sup> and 4<sup>th</sup> bytes respectively.
- (3) Transfer the number of the ID code in the 5<sup>th</sup> byte.
- (4) From the 6<sup>th</sup> byte onward, transfer the IDs from the 1<sup>st</sup> ID code (ID1).



**Fig.EE-10 Timing of ID check function**

**ID code**

If the flash memory is not blank, the input ID codes are compared with that written in flash memory. If they do not match, the input commands will not be accepted. Each ID code contains 8 bits data. Beginning from the 1<sup>st</sup> ID byte, the address of each ID code is 0FFFDF<sub>16</sub>, 0FFFE0<sub>16</sub>, 0FFFE3<sub>16</sub>, 0FFFE4<sub>16</sub>, 0FFFE7<sub>16</sub>, 0FFFE8<sub>16</sub>, 0FFFEB<sub>16</sub>, 0FFFEF<sub>16</sub>, 0FFFF0<sub>16</sub>, 0FFFF3<sub>16</sub>, 0FFFF4<sub>16</sub>, 0FFFF7<sub>16</sub>, 0FFFF8<sub>16</sub>, 0FFFFB<sub>16</sub> and 0FFFFC<sub>16</sub> to 0FFFFF<sub>16</sub> respectively. Write the program with the ID codes in these addresses to the flash memory.

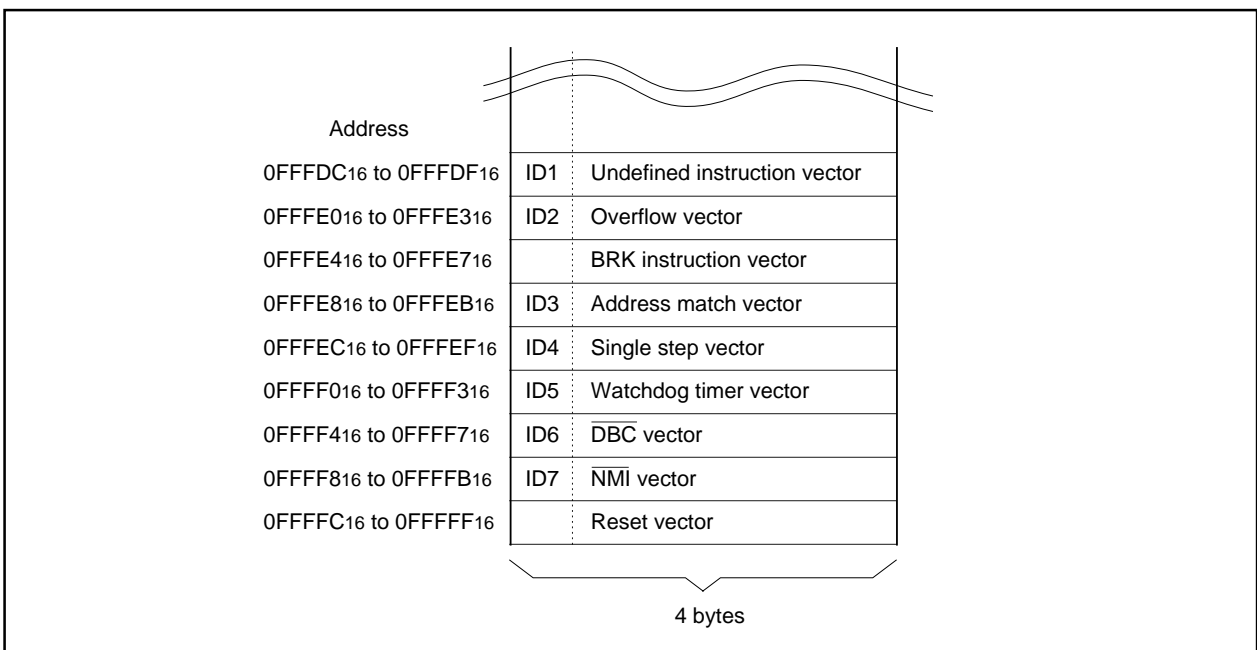

**Fig.EE-11 ID code addressed**

**Read check data**

Read check data command is for conforming if the reprogram data sent after page program command have been received correctly.

- (1) Transfer the command code "FD16" in the 1<sup>st</sup> byte.
- (2) Transfer check data (low) and check data (high) in the 2<sup>nd</sup> and 3<sup>rd</sup> bytes respectively.

When using read check data command, the command should be issued at first to initialize the check data. The next is to issue the page program command and related reprogram data. After that, by issuing the read check data command again, the check data for the reprogram data issued between the two read check data command can be read out.

Adding the reprogram data in byte unit and then calculating the lower 2 bytes of the added data in two's complement gives out the check data.

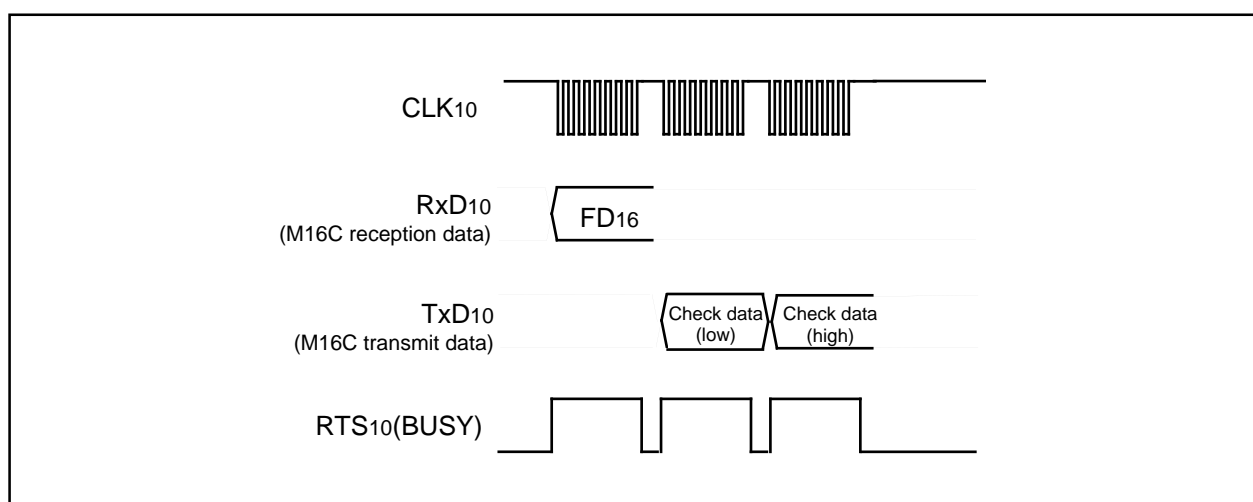

**Fig.EE-12 Timing of read check data command**

**Status register**

Status register indicates if the operation to the flash memory ends successfully or in error. It can be read by issuing the read status register command (70<sub>16</sub>). The status register can be cleared by issuing the clear status register command (50<sub>16</sub>).

Table EE-3 shows the definition of each bit of the register.

After reset, status register outputs "80<sub>16</sub>".

**Table EE-3 Status register (SRD)**

Symbol	Status	Definition	
		"1"	"0"
SR7 (D7)	Sequencer status	Ready	Busy
SR6 (D6)	Reserved	-	-
SR5 (D5)	Erase status	Terminated in error	Terminated normally
SR4 (D4)	Program status	Terminated in error	Terminated normally
SR3 (D3)	Reserved	-	-
SR2 (D2)	Reserved	-	-
SR1 (D1)	Reserved	-	-
SR0 (D0)	Reserved	-	-

**Sequencer status (SR7)**

After power-on, the sequencer status is set to "1" (ready).

The bit is set to "0" (busy) during program and erase operations and is set to "1" upon the completion of these operations.

**Erase status (SR5)**

Erase status indicates the status of erase operation. When erase error occurs, it is set to "1".

The bit becomes "0" when it is cleared.

**Program status (SR4)**

Program status indicates the status of program operation. When program error occurs, it is set to "1".

The bit becomes "0" when it is cleared.



**Status register 1 (SRD1)**

Status register 1 indicates the status of serial communication, the result of ID codes comparison, the result of checksum comparison etc. It can be read after SDR by issuing the read status register command (70<sub>16</sub>). The register can be cleared by issuing the clear status register command (50<sub>16</sub>).

Table EE-4 shows the definition of each bit of the register.

After power on, status register 1 outputs "00<sub>16</sub>".

Table EE-4 Status register (SRD1)

Each bit of SRD	Status name	Definition	
		"1"	"0"
SR15 (bit7)	Boot update completed bit	Update completed	Not update
SR14 (bit6)	Reserved	-	-
SR13 (bit5)	Reserved	-	-
SR12 (bit4)	Check sum match bit	Match	Mismatch
SR11 (bit3) SR10 (bit2)	ID check completed bits	00 Not verified 01 Verified with mismatch 10 Reserved 11 Verified with match	
SR9 (bit1)	Timeout of data reception	Timeout	Normal operation
SR8 (bit0)	Reserved	-	-

**Boot update completed bit (SR15)**

The flag indicates that if the control program has been downloaded to RAM with download function.

**Check sum match bit (SR12)**

The flag indicates if the check sum is matched when downloading the control program with download function.

**ID check completed bits (SR11, SR10)**

These bits indicate the result of ID checks. Some commands cannot be accepted without the ID checks.

**Timeout of data reception bit (SR9)**

The flag indicates if timeout occurs during data reception. If the bit is set to "1" during data reception, microcomputer will discard the received data and return to wait state.

**Full status check**

By performing full status check, the execution result of erase and program operations can be known. Fig.EE-13 shows the full status check flowchart and the method to deal with the error.

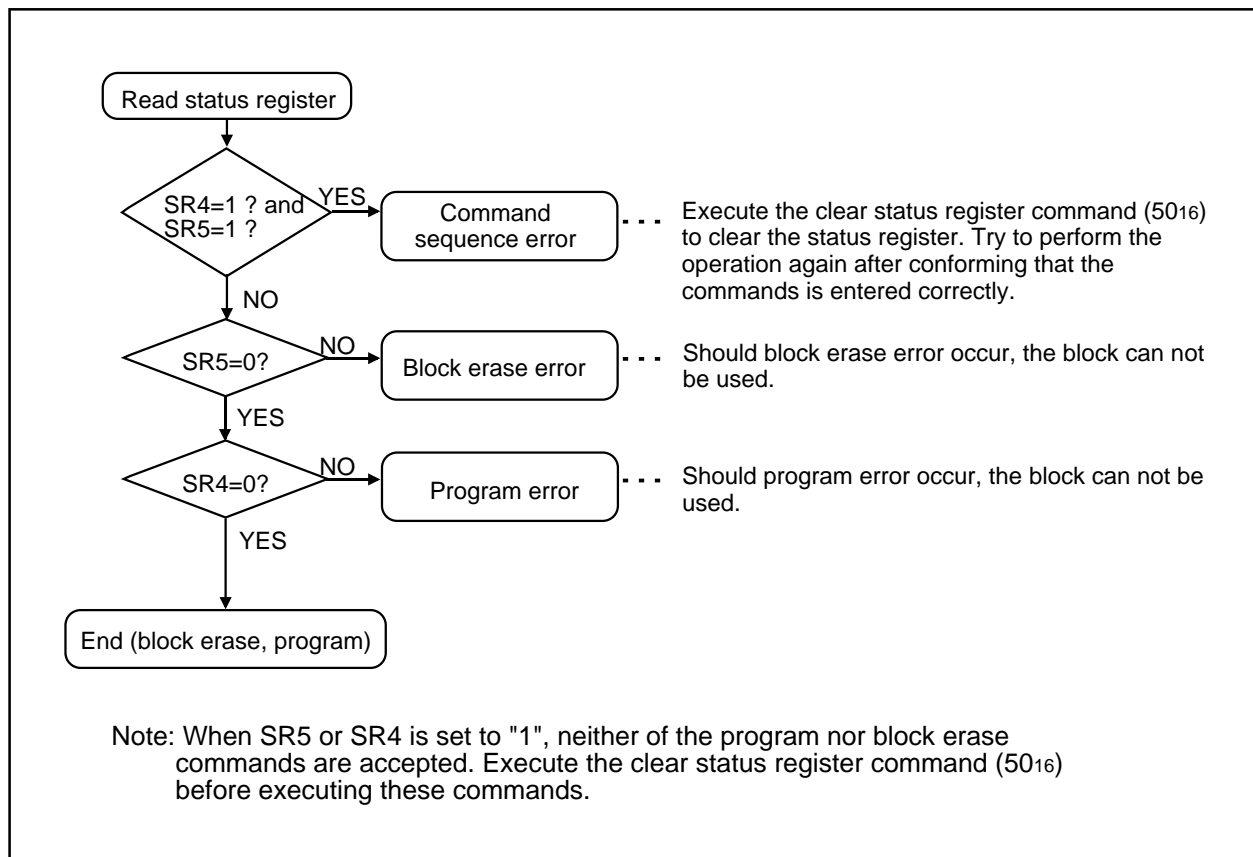

**Fig.EE-13 Full status check flowchart and the method to deal with errors**

**Circuit applied for standard serial I/O mode (example)**

The figure below shows a circuit applied for standard serial I/O mode. The control pins vary by different programmer. Refer to programmer manual for the detail.

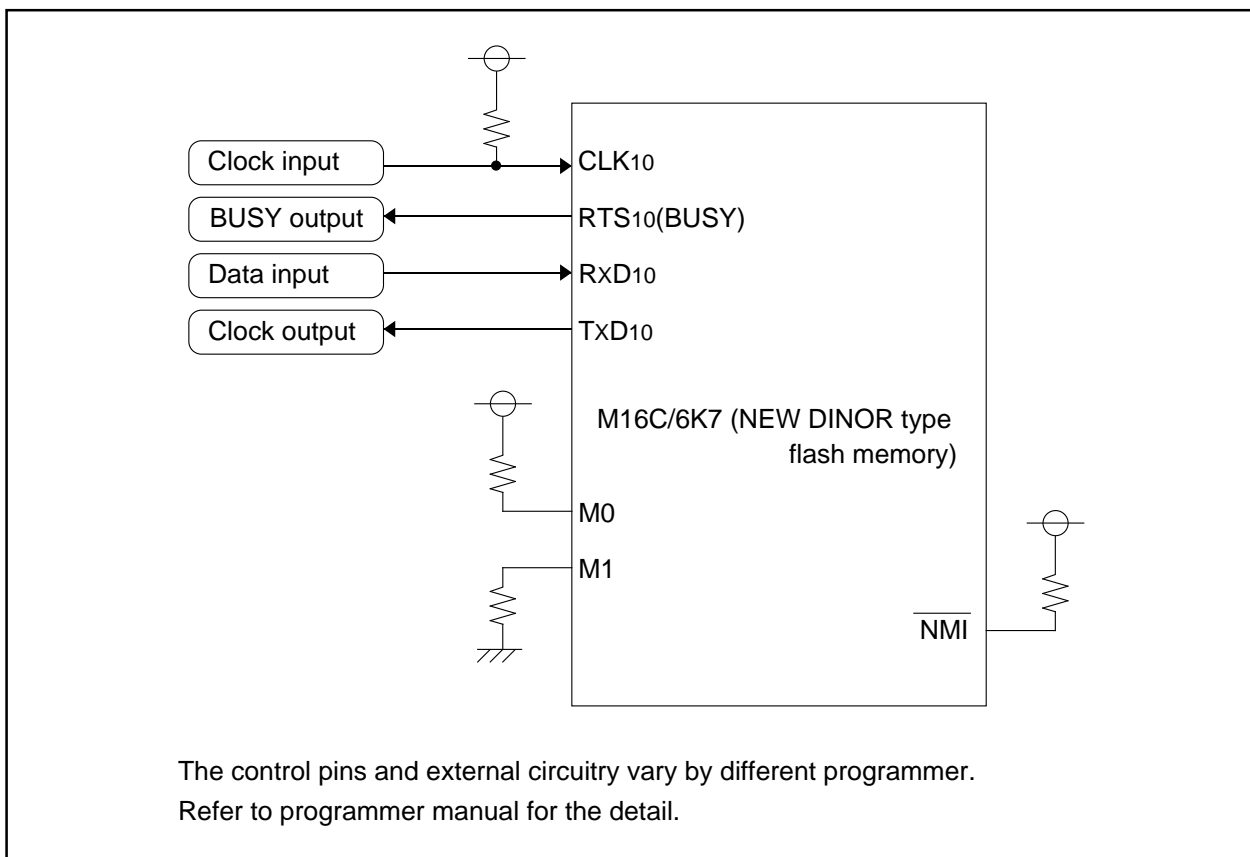

**Fig.EE-14 Example circuit applied for the standard serial I/O mode**

REVISION HISTORY

M16C / 6K7 GROUP DATA SHEET

Rev.	Date	Description	
		Page	Summary
1.0	'01.10.23	149 168  169 170	Misprints, omissions and text styles are revised. Table GF-1 is added. Explanation of "●OBF0 mergence function" is added. Explanation of Figure SI-5 is revised. Figure SI-6 is added. Explanation of "●Serial interrupt control register 2 SERCON2" is added. Figure SI-7 is added.

# Renesas Technology Corp.

Nippon Bldg., 6-2, Otemachi 2-chome, Chiyoda-ku, Tokyo, 100-0004 Japan

## Keep safety first in your circuit designs!

- Mitsubishi Electric Corporation puts the maximum effort into making semiconductor products better and more reliable, but there is always the possibility that trouble may occur with them. Trouble with semiconductors may lead to personal injury, fire or property damage. Remember to give due consideration to safety when making your circuit designs, with appropriate measures such as (i) placement of substitutive, auxiliary circuits, (ii) use of non-flammable material or (iii) prevention against any malfunction or mishap.

## Notes regarding these materials

- These materials are intended as a reference to assist our customers in the selection of the Mitsubishi semiconductor product best suited to the customer's application; they do not convey any license under any intellectual property rights, or any other rights, belonging to Mitsubishi Electric Corporation or a third party.
- Mitsubishi Electric Corporation assumes no responsibility for any damage, or infringement of any third-party's rights, originating in the use of any product data, diagrams, charts, programs, algorithms, or circuit application examples contained in these materials.
- All information contained in these materials, including product data, diagrams, charts, programs and algorithms represents information on products at the time of publication of these materials, and are subject to change by Mitsubishi Electric Corporation without notice due to product improvements or other reasons. It is therefore recommended that customers contact Mitsubishi Electric Corporation or an authorized Mitsubishi Semiconductor product distributor for the latest product information before purchasing a product listed herein.  
The information described here may contain technical inaccuracies or typographical errors. Mitsubishi Electric Corporation assumes no responsibility for any damage, liability, or other loss rising from these inaccuracies or errors. Please also pay attention to information published by Mitsubishi Electric Corporation by various means, including the Mitsubishi Semiconductor home page (<http://www.mitsubishichips.com>).
- When using any or all of the information contained in these materials, including product data, diagrams, charts, programs, and algorithms, please be sure to evaluate all information as a total system before making a final decision on the applicability of the information and products. Mitsubishi Electric Corporation assumes no responsibility for any damage, liability or other loss resulting from the information contained herein.
- Mitsubishi Electric Corporation semiconductors are not designed or manufactured for use in a device or system that is used under circumstances in which human life is potentially at stake. Please contact Mitsubishi Electric Corporation or an authorized Mitsubishi Semiconductor product distributor when considering the use of a product contained herein for any specific purposes, such as apparatus or systems for transportation, vehicular, medical, aerospace, nuclear, or undersea repeater use.
- The prior written approval of Mitsubishi Electric Corporation is necessary to reprint or reproduce in whole or in part these materials.
- If these products or technologies are subject to the Japanese export control restrictions, they must be exported under a license from the Japanese government and cannot be imported into a country other than the approved destination.  
Any diversion or reexport contrary to the export control laws and regulations of Japan and/or the country of destination is prohibited.
- Please contact Mitsubishi Electric Corporation or an authorized Mitsubishi Semiconductor product distributor for further details on these materials or the products contained therein.