



4-Channel Quad-Mode™ LED Driver with Open/Short LED Detection

FEATURES

- Quad-mode charge pump: 1x, 1.33x, 1.5x, 2x
- Drives up to 4 LEDs at 30mA each
- Pin compatible with industry standard '604
- Open/short LED automatic detection
- Power efficiency up to 92%
- High resolution PWM dimming
- Low noise supply ripple in all modes
- Soft start and current limiting
- Short circuit and thermal overload protection
- 16-Pad TQFN package, 4mm x 4mm

APPLICATION

- LCD Display Backlight
- Cellular Phones
- Digital Still Cameras
- Handheld Devices

ORDERING INFORMATION

Part Number	Package	Qty per Reel	Marking
CAT3604VHV4-GT2	TQFN-16 ⁽¹⁾ 4 x 4mm	2000	CDAK
CAT3604VHV4-T2	TQFN-16 4 x 4mm	2000	CDAF

Note:

(1) NiPdAu Plated Finish, RoHS compliant
For other finishes, please contact factory

For Ordering Information details, see page 14.

PIN CONFIGURATION

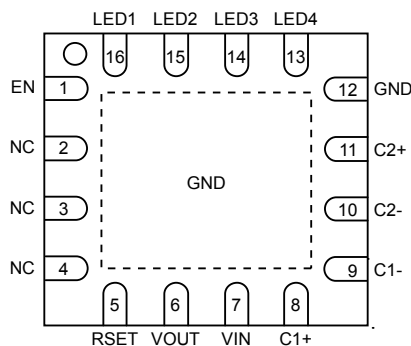

DESCRIPTION

The CAT3604V is a high efficiency Quad-Mode™ fractional charge pump that can drive up to four LEDs with input supply voltages as low as 2.5V.

An external RSET resistor is used to control the LED channel brightness while channel diagnostics include automatic detection for both short and open LED channel conditions, ensuring the CAT3604V maintains the highest efficiency level in all operating modes.

Each operating mode uses a constant high frequency switching scheme which allows the use of small form factor external ceramic capacitors while delivering excellent low noise input supply ripple up to 5.5 volts.

The EN input control supports direct PWM dimming and can accommodate dimming frequencies in excess of 10kHz thereby providing extremely high resolution brightness levels.

The device is available in the 16-pad low profile 0.8mm thin QFN (4mm x 4mm).

TYPICAL APPLICATION CIRCUIT

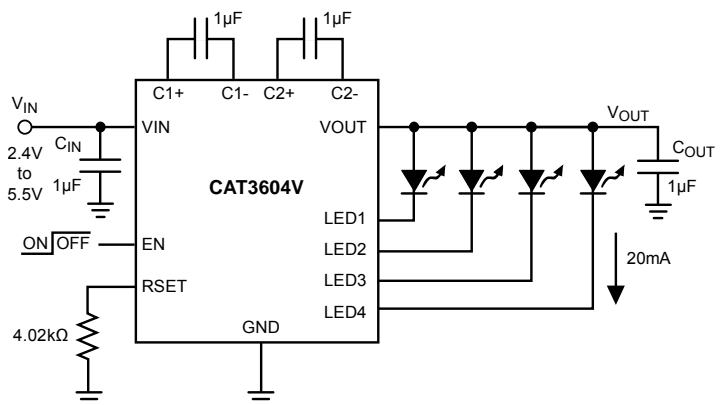

ABSOLUTE MAXIMUM RATINGS

Parameter	Rating	Unit
V _{IN} , LED _x , C1±, C2± voltage	6	V
V _{OUT} voltage	7	V
EN voltage	6	V
Storage Temperature Range	-65 to +160	°C
Junction Temperature Range	-40 to +150	°C
Lead Temperature	300	°C

RECOMMENDED OPERATING CONDITIONS

Parameter	Rating	Unit
V _{IN}	2.5 to 5.5	V
Ambient Temperature Range	-40 to +85	°C
I _{LED} per LED pin	0 to 25	mA
Total Output Current	0 to 100	mA
LED Forward Voltage Range	1.3 to 4.3	V

Typical application circuit with external components is shown on page 1.

ELECTRICAL OPERATING CHARACTERISTICS

(over recommended operating conditions unless specified otherwise) V_{IN} = 3.6V, EN = High, T_{AMB} = 25°C

Symbol	Name	Conditions	Min	Typ	Max	Units
I _Q	Quiescent Current	1x mode, no load		1.0		mA
		1.33x mode, no load		1.7		mA
		1.5x mode, no load		2.2		mA
		2x mode, no load		2.4		mA
I _{QSHDN}	Shutdown Current	V _{EN} = 0V			1	µA
I _{LED-ACC}	LED Current Accuracy	I _{LEDAVG} / I _{LEDAVG-NOMINAL}		±2		%
I _{LED-DEV}	LED Channel Matching	(I _{LED} - I _{LEDAVG}) / I _{LEDAVG}		±1.5		%
I _{LED}	Programmed LED Current	R _{SET} = 34.0kΩ		2.4		mA
		R _{SET} = 5.23kΩ		15		
		R _{SET} = 2.67kΩ		30		
V _{RSET}	RSET Regulated Voltage		0.58	0.6	0.62	V
R _{OUT}	Output Resistance (open loop)	1x mode		0.8		Ω
		1.33x mode, V _{IN} = 3V		5		Ω
		1.5x mode, V _{IN} = 2.7V		5		Ω
		2x mode, V _{IN} = 2.4V		10		Ω
F _{OSC}	Charge Pump Frequency	1.33x and 2x mode	0.8	1	1.3	MHz
		1.5x mode	1	1.3	1.6	MHz
I _{SC_MAX}	Output short circuit Current Limit	V _{OUT} < 0.5V		50		mA
I _{IN_MAX}	Input Current Limit	V _{OUT} > 1V		250		mA
LED _{TH}	1x to 1.33x, 1.33x to 1.5x or 1.5x to 2x Transition Thresholds at any LED pin			130		mV
V _{HYS}	1x Mode Transition Hysteresis			400		mV
R _{EN}	EN Pin					
V _{HI}	• Internal Pull-down Resistor		1.3	100		kΩ
V _{LO}	• Logic High Level					V
	• Logic Low Level				0.4	V
T _{SD}	Thermal Shutdown			150		°C
T _{HYS}	Thermal Hysteresis			20		°C
V _{UVLO}	Undervoltage lockout (UVLO) threshold		1.6	1.8	2.0	V

A.C. CHARACTERISTICS

For $2.5V \leq V_{IN} \leq 5.5V$, over full ambient temperature range -40 to $+85^{\circ}C$.

Symbol	Name	Conditions	Min	Typ	Max	Units
T_{LED}	LED current settling time from shutdown mode	1x mode, $V_{IN} = 4V$ 1.33x mode, $V_{IN} = 3.5V$		40 400		μs
T_{MD}	Mode transition time			500		μs
T_{PWRDWN}	Device power down delay			0.9	1.5	ms
T_{LED-ON}	LED on settling time			1		μs
$T_{LED-OFF}$	LED off settling time			120		ns

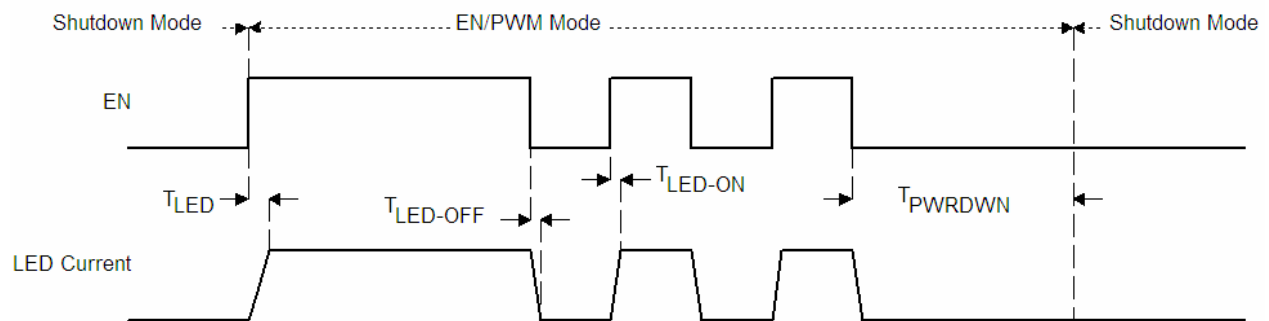

Figure 1. CAT3604V Timing Characteristics

LED Current Setting

The nominal LED current is set by the external resistor connected between the RSET pin and ground. Table 1 lists standard resistor values for several LED current settings.

LED current (mA)	RSET (k Ω)
2	40.0
5	15.8
10	7.87
15	5.23
20	4.02
25	3.16
30	2.67

Table 1. Resistor RSET and LED current

CAT3604V

TYPICAL PERFORMANCE CHARACTERISTICS

$V_{IN} = 3.6V$, $I_{OUT} = 80mA$ (4 LEDs at 20mA), $C_{IN} = C_{OUT} = C_1 = C_2 = 1\mu F$, $T_{AMB} = 25^\circ C$ unless otherwise specified.

Efficiency vs. Input Voltage

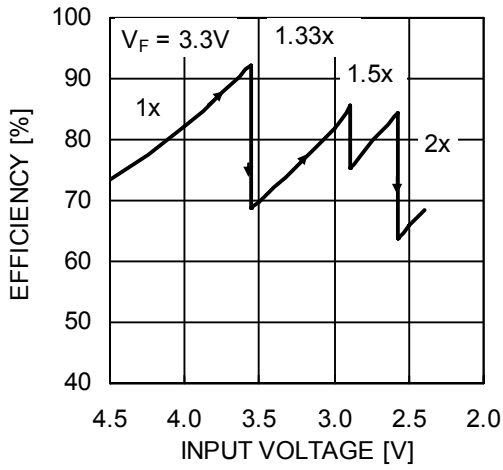

Efficiency vs. Li-Ion Voltage

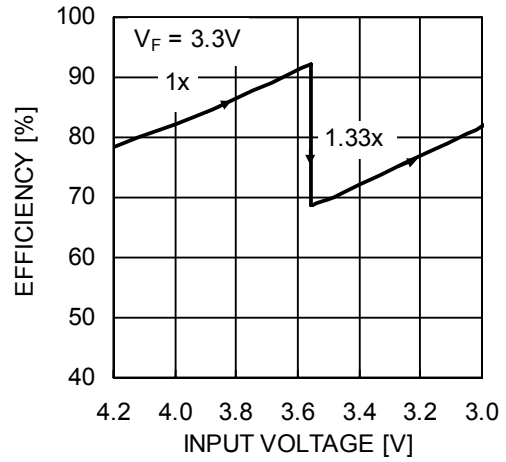

Quiescent Current vs. Input Voltage

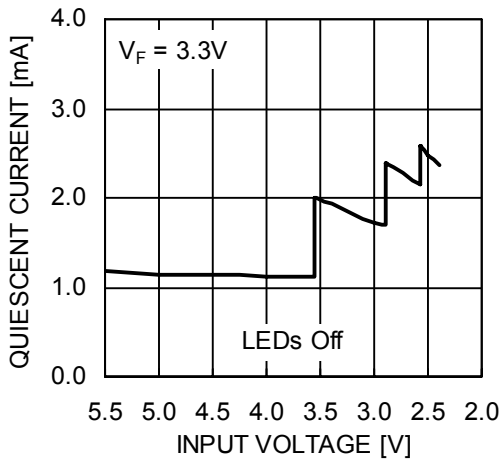

Quiescent Current vs. Temperature

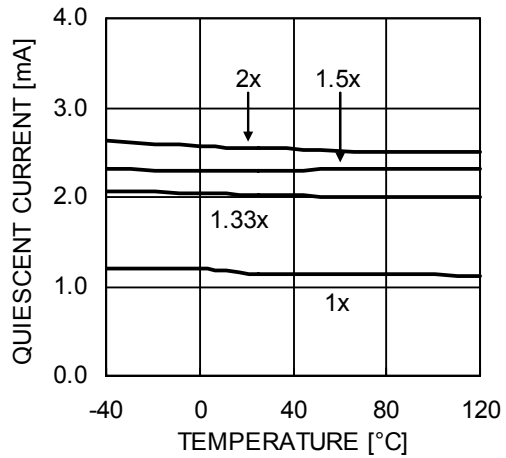

LED Current Change vs. Input Voltage

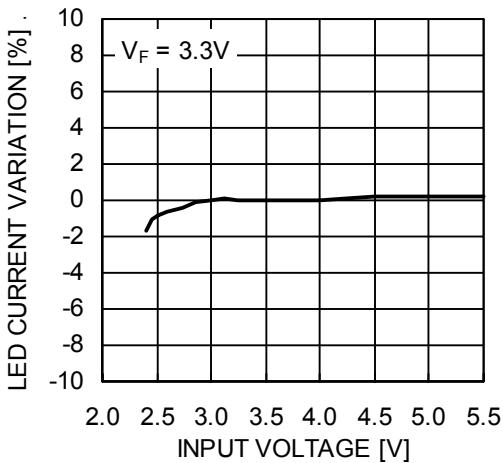

LED Current Change vs. Temperature

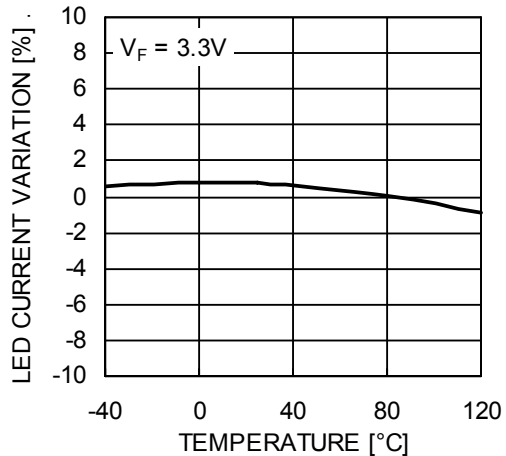

TYPICAL PERFORMANCE CHARACTERISTICS

$V_{IN} = 3.6V$, $I_{OUT} = 80mA$ (4 LEDs at 20mA), $C_{IN} = C_{OUT} = C_1 = C_2 = 1\mu F$, $T_{AMB} = 25^\circ C$ unless otherwise specified.

Switching Frequency vs. Temperature

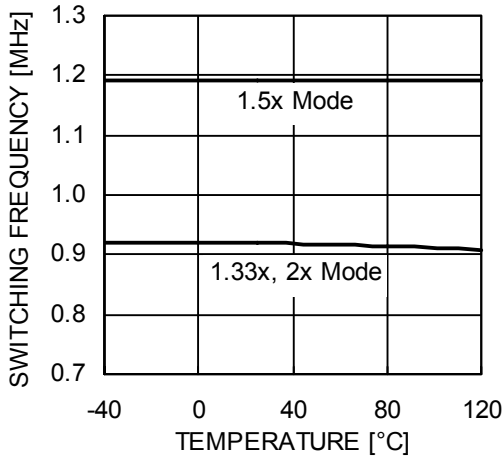

Output Resistance vs. Input Voltage

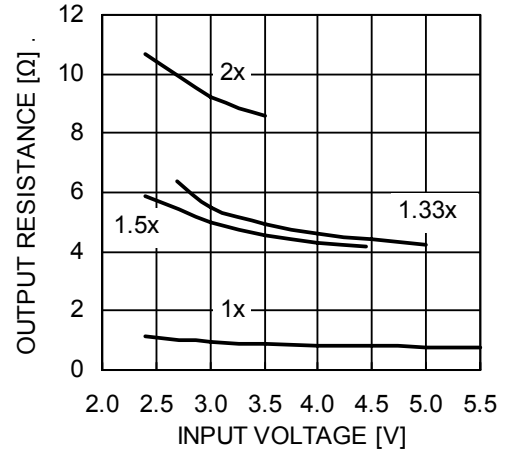

Foldback Current Limit

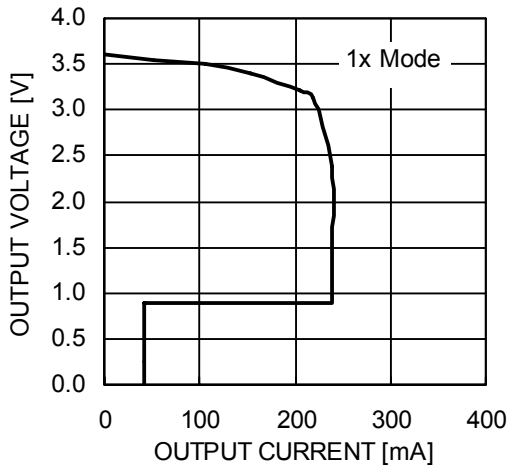

LED Current vs. LED Pin Voltage

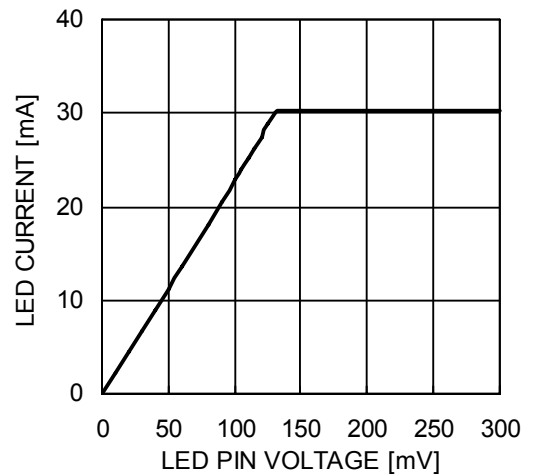

LED Current vs. RSET Resistance

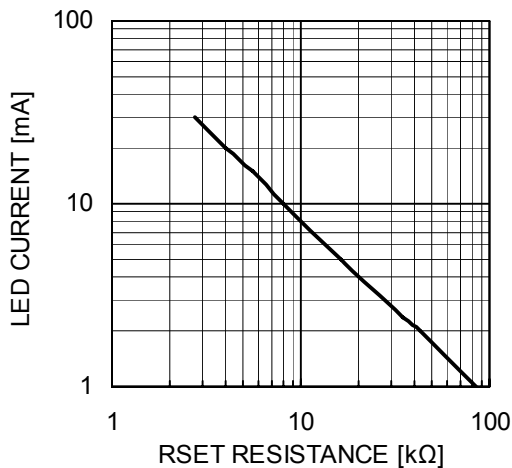

Line Transient Response (3.6V to 4.9V)

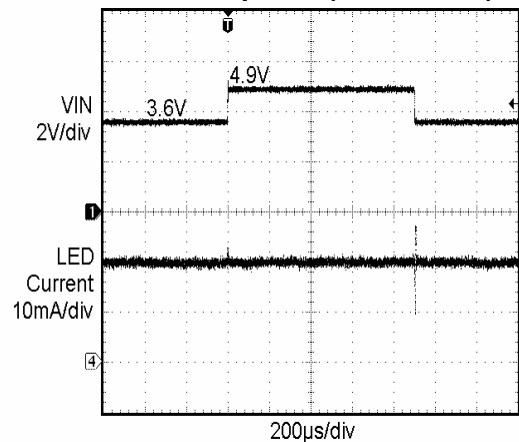

TYPICAL PERFORMANCE CHARACTERISTICS

$V_{IN} = 3.6V$, $I_{OUT} = 80mA$ (4 LEDs at 20mA), $C_{IN} = C_{OUT} = C_1 = C_2 = 1\mu F$, $T_{AMB} = 25^{\circ}C$ unless otherwise specified.

Operating Waveforms in 1x Mode

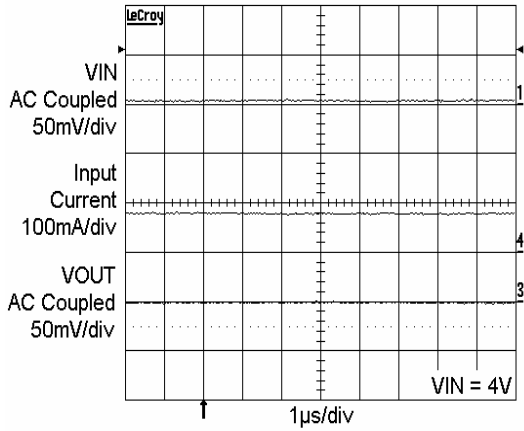

Switching Waveforms in 1.33x Mode

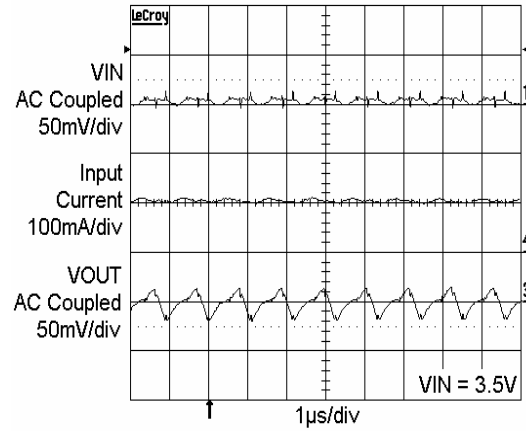

Switching Waveforms in 1.5x Mode

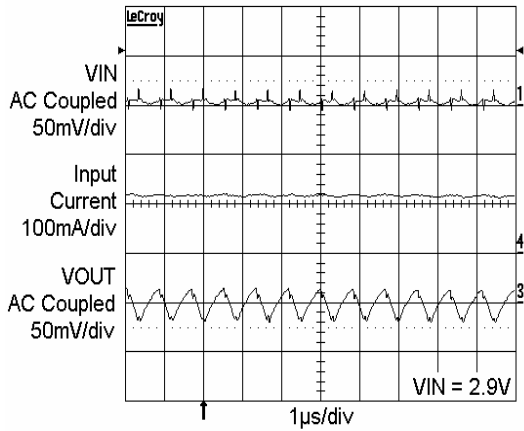

Switching Waveforms in 2x Mode

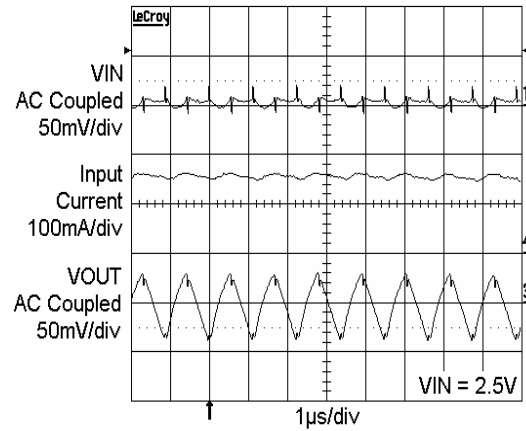

TYPICAL PERFORMANCE CHARACTERISTICS

$V_{IN} = 3.6V$, $I_{OUT} = 80mA$ (4 LEDs at 20mA), $C_{IN} = C_{OUT} = C_1 = C_2 = 1\mu F$, $T_{AMB} = 25^\circ C$ unless otherwise specified.

Cold Power Up in 1x Mode

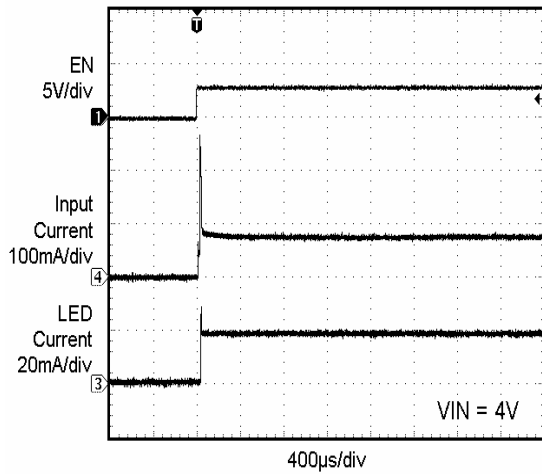

Cold Power Up in 1.33x Mode

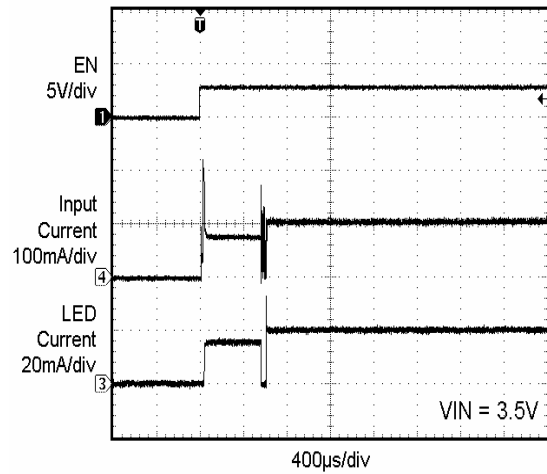

Cold Power Up in 1.5x Mode

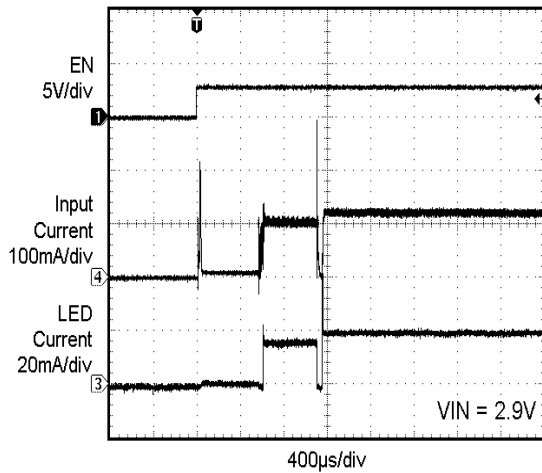

Cold Power Up in 2x Mode

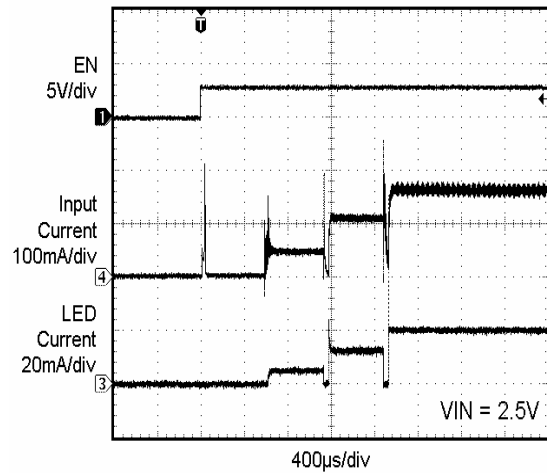

Cold Power Up (1x Mode)

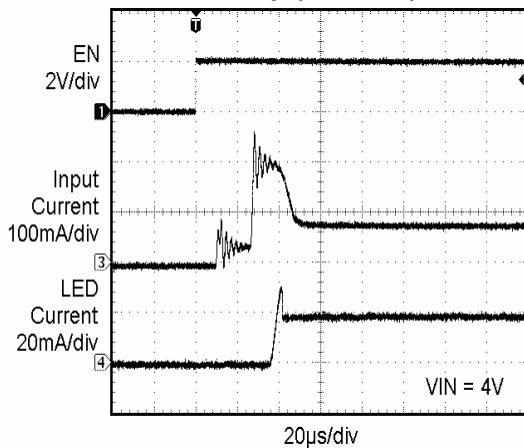

Power Down (1x Mode)

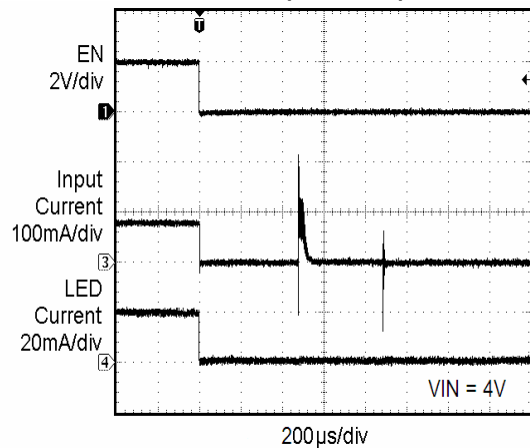

PIN DESCRIPTION

Pin #	Name	Function
1	EN	Device enable (active high).
2	NC	Not connected inside the package.
3	NC	Not connected inside the package.
4	NC	Not connected inside the package.
5	RSET	Connect resistor RSET to set the LED current.
6	VOUT	Charge pump output connected to the LED anodes.
7	VIN	Charge pump input, connect to battery or supply.
8	C1+	Bucket capacitor 1 Positive terminal
9	C1-	Bucket capacitor 1 Negative terminal
10	C2-	Bucket capacitor 2 Negative terminal
11	C2+	Bucket capacitor 2 Positive terminal
12	GND	Ground Reference
13	LED4	LED4 cathode terminal.
14	LED3	LED3 cathode terminal.
15	LED2	LED2 cathode terminal.
16	LED1	LED1 cathode terminal.
TAB	GND	Connect to GND on the PCB.

PIN FUNCTION

VIN is the supply pin for the charge pump. A small 1 μ F ceramic bypass capacitor is required between the VIN pin and ground near the device. The operating input voltage range is from 2.5V to 5.5V. Whenever the input supply falls below the under-voltage threshold (1.8V), all the LED channels are disabled and the device enters shutdown mode.

EN is the enable input and the high resolution PWM dimming control. Levels of logic high and logic low are set at 1.3V and 0.4V respectively. When EN is initially taken high, the device becomes enabled and all LED currents are set according to the R_{SET} resistor. To place the device into “zero current” shutdown mode, the EN pin must be held low for at least 1.5ms.

VOUT is the charge pump output that is connected to the LED anodes. A small 1 μ F ceramic bypass capacitor is required between the V_{OUT} pin and ground near the device.

GND is the ground reference for the charge pump. The pin must be connected to the ground plane on the PCB.

C1+, C1- are connected to each side of the ceramic bucket capacitor C₁.

C2+, C2- are connected to each side of the ceramic bucket capacitor C₂.

LED1 to LED4 provide the internal regulated current source for each of the LED cathodes. These pins enter high-impedance zero current state whenever the device is placed in shutdown mode. If an LED pin is directly tied to VOUT, that channel is disabled.

TAB is the exposed pad underneath the package. For best thermal performance, the tab should be soldered to the PCB and connected to the ground plane.

RSET is connected to the resistor (R_{SET}) to set the current for the LEDs. The voltage at this pin regulated to 0.6V. The ground side of the external resistor should be star connected back to the GND of the PCB. In shutdown mode, RSET becomes high impedance.

BLOCK DIAGRAM

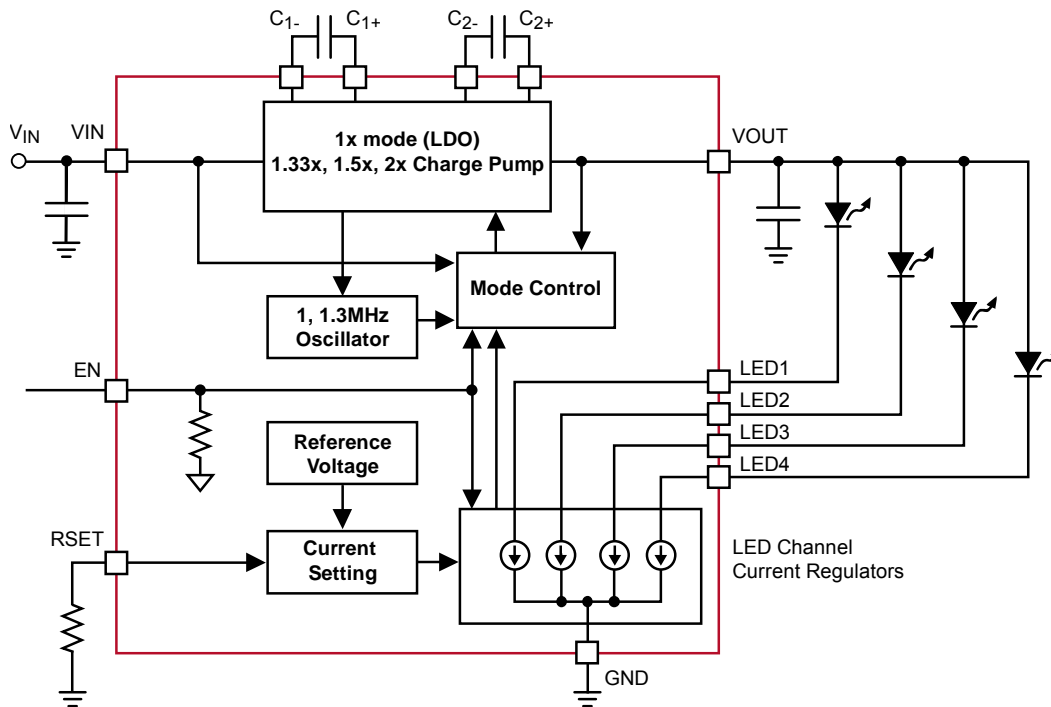

Figure 2. CAT3604V Functional Block Diagram

BASIC OPERATION

At power-up, the CAT3604V starts operating in 1x mode where the output will be approximately equal to the input supply voltage (less any internal voltage losses). If the output voltage is sufficient to regulate all LED currents, the device remains in 1x operating mode.

If the input voltage is insufficient or falls to a level where the regulated currents cannot be maintained, the device automatically switches into 1.33x mode (after a fixed delay time of about 400µs). In 1.33x mode, the output voltage is approximately equal to 1.33 times the input supply voltage (less any internal voltage losses).

This sequence repeats in the 1.33x and 1.5x mode until the driver enters the 2x mode. In 1.5x mode, the output voltage is approximately equal to 1.5 times the input supply voltage. While in 2x mode, the output is approximately equal to 2 times the input supply voltage.

If the device detects a sufficient input voltage is present to drive all LED currents in 1x mode, it will change automatically back to 1x mode. This only applies for changing back to the 1x mode. The difference between the input voltage when exiting 1x

mode and returning to 1x mode is called the 1x mode transition hysteresis (V_{HYS}) and is about 500mV

LED Current Selection

The LED current is set to by the external resistor RSET as follows:

$$\text{LED current} = 132 \times \frac{0.6V}{R_{SET}}$$

The EN pin enables and disables the device. The LED driver enters a “zero current” shutdown mode if EN is held low for 1.5ms or more.

As soon as the EN input goes low, all LED channels are instantly disabled, where the LED current is set to zero. As long as the CAT3604V is not in shutdown mode, the LEDs turn on as soon as the EN goes high.

CAT3604V

Unused LED Channels

For applications not requiring all the channels, it is recommended to connect the unused LED pins directly to VOUT (see Figure 3).

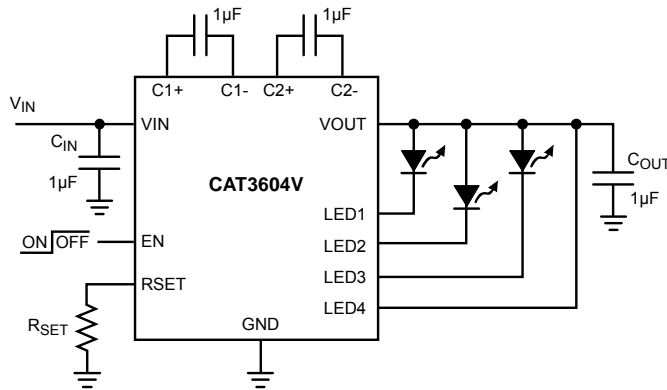

Figure 3. Application with 3 LEDs

Protection Mode

If an LED is disconnected, the device senses that, run the diagnostics, then ignores that channel and goes back to the most effective mode. When all LEDs are disconnected, the device runs diagnostics and goes to 1x mode where the output is basically equal to the input voltage.

As soon as the output exceeds about 6V, the driver resets itself and reevaluate the mode.

If the die temperature reaches +150°C, the device enters a thermal protection shutdown mode. When the device temperature drops to about +130°C, the device resumes normal operation.

LED Selection

LEDs with forward voltages (V_F) ranging from 1.3V to 4.3V may be used. Selecting LEDs with lower V_F is recommended in order to extend battery life and keep the driver in 1x mode longer as the battery voltage decreases.

For example, if a 3.3V V_F LED is selected instead of a 3.5V V_F LED, the driver will stay in 1x mode for a lower supply voltage of 0.2V.

External Components

The driver requires four external 1µF ceramic capacitors for decoupling input, output, and for the charge pump. Both capacitors type X5R and X7R are recommended for the LED driver application. In all charge pump modes, the input current ripple is kept very low by design and an input bypass capacitor of 1µF is sufficient.

In 1x mode, the device operates in linear mode and does not introduce switching noise back onto the supply.

Recommended Layout

In charge pump mode, the driver switches internally at a high frequency. It is recommended to minimize trace length to all four capacitors. A ground plane should cover the area under the driver IC as well as the bypass capacitors. Short connection to ground on capacitors C_{IN} and C_{OUT} can be implemented with the use of multiple via. A copper area matching the TQFN exposed pad (TAB) must be connected to the ground plane underneath. The use of multiple via improves the package heat dissipation.

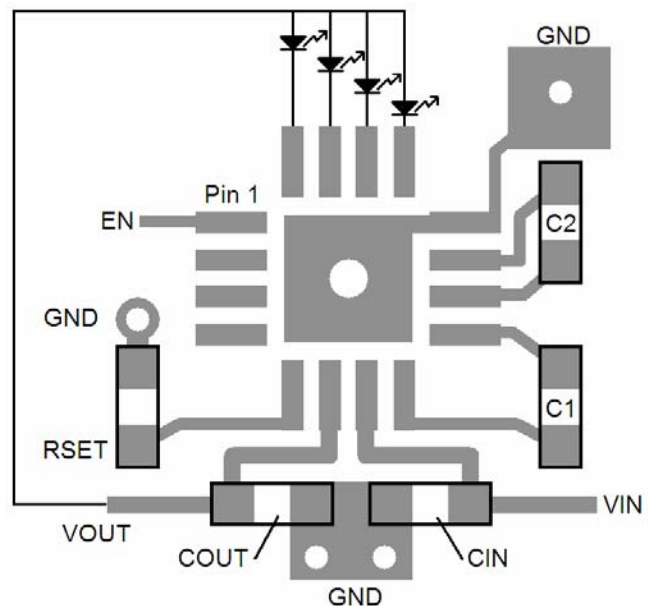

Figure 4. PCB Layout

PWM DIMMING

The EN pin is used to provide total Shutdown of the device as well as High Resolution PWM dimming control on the LED Channels.

Shutdown of the device occurs after the EN pin has been held low for 1.5ms. During the “soft-start” power-up sequence from the shutdown mode, the LED current typically settles within 40μs (for 1X mode operation). This LED current settling time becomes 400μs if 1.33X operation is needed (i.e low battery voltage).

For High Resolution PWM dimming control (typically frequencies at 2kHz or above), the device will remain powered and only the LED channels output will be switched on and off during the PWM (the rest of the device will remain powered-up). This allows the output channels to have “instant-on” response, where the LED current settles within 1μs of the applied PWM dimming signals. This “instant-on” modes makes the device suitable for extremely high frequency PWM dimming schemes.

Figure 5 shows the output current for PWM frequencies up to 100kHz and with duty cycles of 30% and 70%.

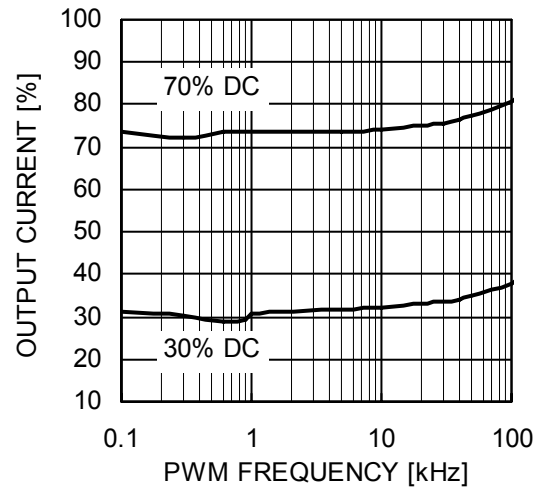

Figure 5. Output current vs. PWM frequency

For best performance, the duty cycle off-time T_{OFF} should meet the following timing limits:

- for slow frequency $\leq 600\text{Hz}$, $T_{OFF} \geq 800\mu\text{s}$
- for fast frequency $\geq 1\text{kHz}$, $T_{OFF} \leq 400\mu\text{s}$

CAT3604V

TYPICAL PERFORMANCE CHARACTERISTICS

$V_{IN} = 3.6V$, $I_{OUT} = 80mA$ (4 LEDs at 20mA), $C_{IN} = C_{OUT} = C_1 = C_2 = 1\mu F$, $T_{AMB} = 25^{\circ}C$ unless otherwise specified.

10kHz PWM waveform (1x mode)

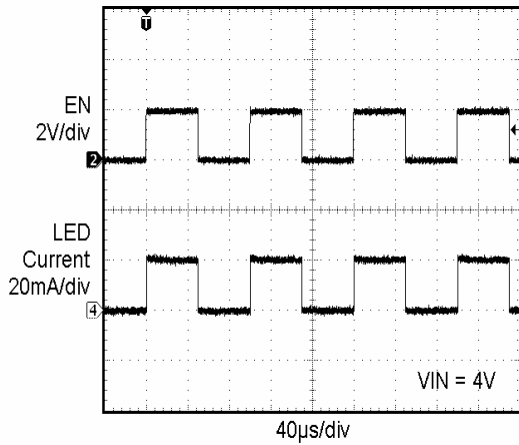

10kHz PWM waveform (1.33x mode)

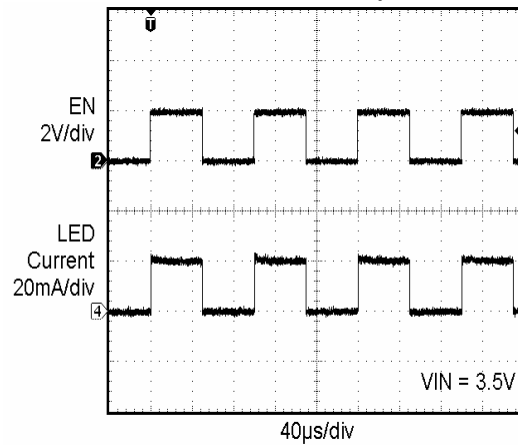

300Hz PWM waveform (1x mode)

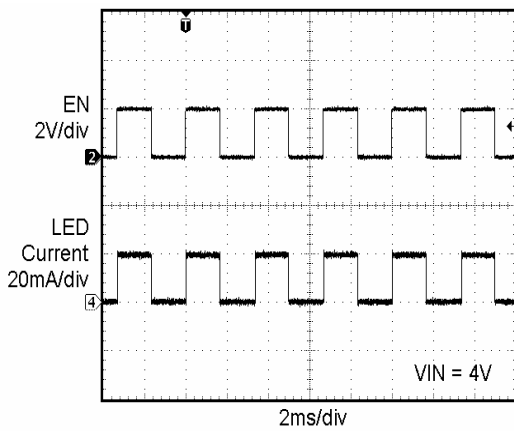

Dimming Linearity, PWM at 200Hz

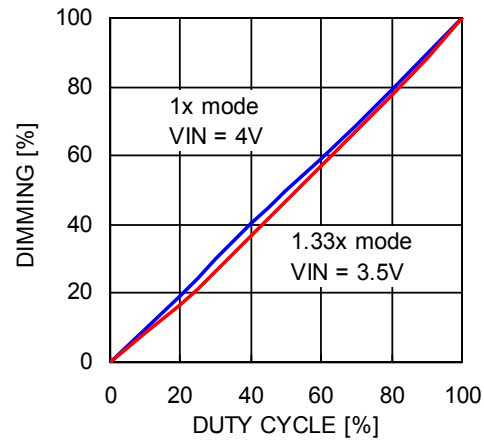

Dimming Linearity, PWM at 500Hz

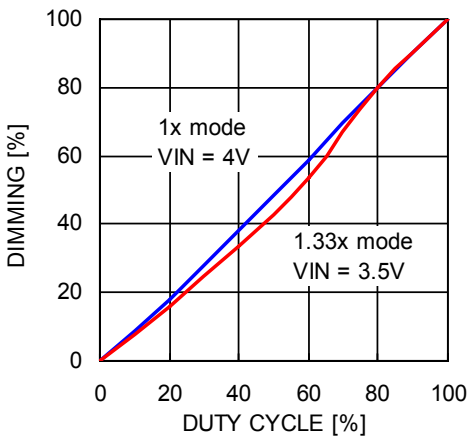

Dimming Linearity, PWM at 30kHz

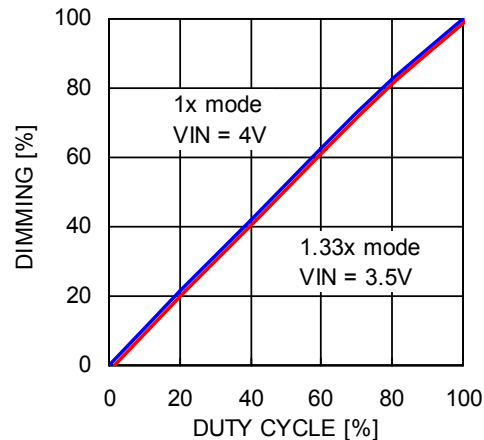

PACKAGE OUTLINE DRAWING

TQFN 16-Pad 4 x 4mm (HV4)⁽¹⁾⁽²⁾

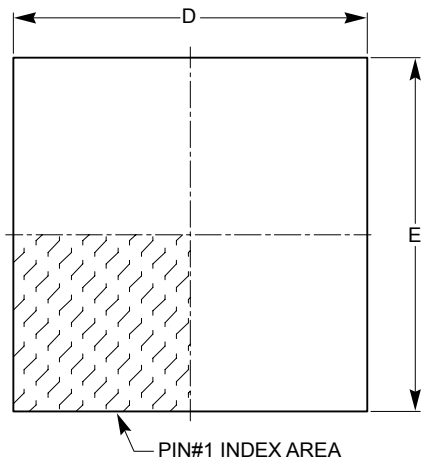

TOP VIEW

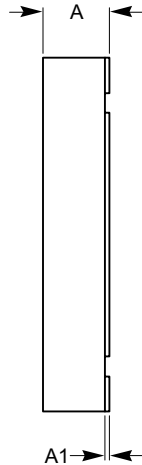

SIDE VIEW

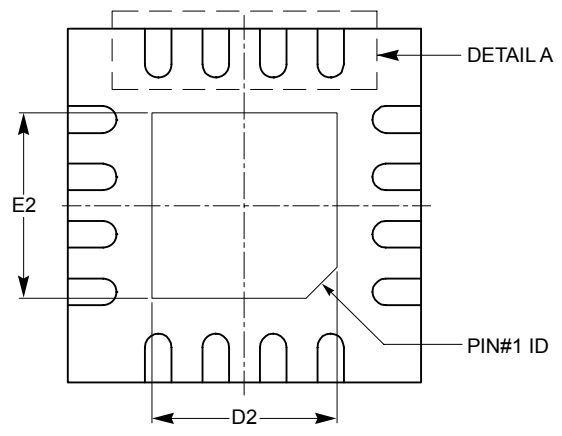

BOTTOM VIEW

SYMBOL	MIN	NOM	MAX
A	0.70	0.75	0.80
A1	0.00	0.02	0.05
A3	0.20 REF		
b	0.25	0.30	0.35
D	3.90	4.00	4.10
D2	2.00	-	2.90
E	3.90	4.00	4.10
E2	2.00	-	2.90
e	0.65 BSC		
L	0.30	-	0.60

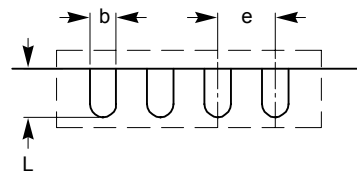

DETAIL A

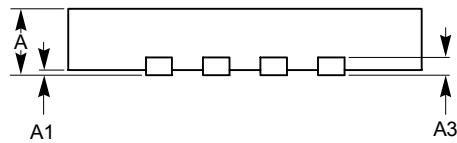

FRONT VIEW

**For current Tape and Reel information, download the PDF file from:
<http://www.catsemi.com/documents/tapeandreel.pdf>.**

Notes:

- (1) All dimensions are in millimeters.
- (2) Complies with JEDEC standard MO-220.

EXAMPLE OF ORDERING INFORMATION

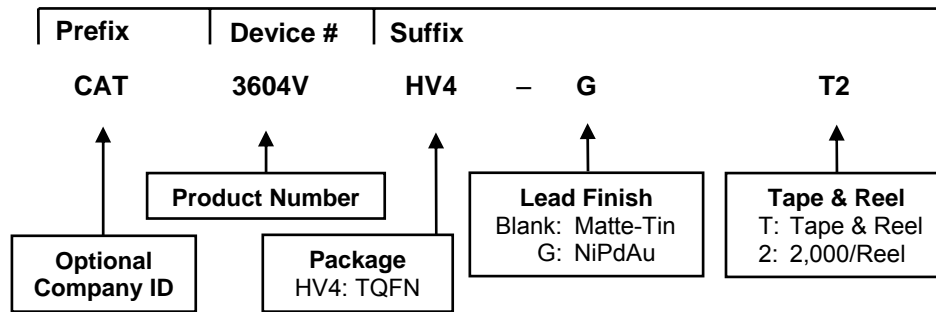

For Product Top Mark Codes, click here:
<http://www.catsemi.com/techsupport/producttopmark.asp>

Notes:

- (1) All packages are RoHS-compliant (Lead-free, Halogen-free).
- (2) The standard lead finish is NiPdAu.
- (3) The device used in the above example is a CAT3604VHV4-GT2 (TQFN, Tape & Reel, 2,000/Reel).
- (4) For additional package and temperature options, please contact your nearest Catalyst Semiconductor Sales office.

REVISION HISTORY

Date	Rev.	Reason
04-Dec-07	A	Initial Release
28-Apr-08	B	Update Package Outline Drawing – TQFN 16-Pad 4 x 4 (HV4)

Copyrights, Trademarks and Patents

© Catalyst Semiconductor, Inc.

Trademarks and registered trademarks of Catalyst Semiconductor include each of the following: Adaptive Analog™, Beyond Memory™, DPP™, EZDim™, LDD™, MiniPot™, Quad-Mode™ and Quantum Charge Programmable™

Catalyst Semiconductor has been issued U.S. and foreign patents and has patent applications pending that protect its products.

CATALYST SEMICONDUCTOR MAKES NO WARRANTY, REPRESENTATION OR GUARANTEE, EXPRESS OR IMPLIED, REGARDING THE SUITABILITY OF ITS PRODUCTS FOR ANY PARTICULAR PURPOSE, NOR THAT THE USE OF ITS PRODUCTS WILL NOT INFRINGE ITS INTELLECTUAL PROPERTY RIGHTS OR THE RIGHTS OF THIRD PARTIES WITH RESPECT TO ANY PARTICULAR USE OR APPLICATION AND SPECIFICALLY DISCLAIMS ANY AND ALL LIABILITY ARISING OUT OF ANY SUCH USE OR APPLICATION, INCLUDING BUT NOT LIMITED TO, CONSEQUENTIAL OR INCIDENTAL DAMAGES.

Catalyst Semiconductor products are not designed, intended, or authorized for use as components in systems intended for surgical implant into the body, or other applications intended to support or sustain life, or for any other application in which the failure of the Catalyst Semiconductor product could create a situation where personal injury or death may occur.

Catalyst Semiconductor reserves the right to make changes to or discontinue any product or service described herein without notice. Products with data sheets labeled "Advance Information" or "Preliminary" and other products described herein may not be in production or offered for sale.

Catalyst Semiconductor advises customers to obtain the current version of the relevant product information before placing orders. Circuit diagrams illustrate typical semiconductor applications and may not be complete.



Catalyst Semiconductor, Inc.
Corporate Headquarters
2975 Stender Way
Santa Clara, CA 95054
Phone: 408.542.1000
Fax: 408.542.1200
www.catsemi.com

Document No: MD-5029
Revision: B
Issue Date: 04/28/08