

HD75161A

Octal General Purpose Interface Bus Transceivers

REJ03D0309-0200Z
 (Previous ADE-205-591 (Z))
 Rev.2.00
 Jul.16.2004

Description

The HD75161A is an 8 channel general purpose interface bus transceiver designed to meet the requirements of IEEE standard 488-1978. The transceiver is to provide the bus management and data transfer signals during operating in a controller instrumentation system. When combined with the HD75160A octal bus transceiver, the HD75161A provides the complete 16 wire interface for the IEEE 488 bus. The HD75161A features eight driver receiver pairs connected in a front to back configuration to form input/output ports at both the bus and terminal sides. The direction of data through these driver receiver pairs is determined by the DC and TE enable signals. The device exhibits a high impedance to the bus when $V_{CC} = 0\text{ V}$ since the bus terminating resistors are built in. It features driver outputs which can handle loads up to 48 mA of sink current. Each receiver features p n p transistor inputs for high input impedance and guaranteed hysteresis of 400 mV for increased noise immunity.

Features

- Ordering Information

Part Name	Package Type	Package Code	Package Abbreviation	Taping Abbreviation (Quantity)
HD75161AP	DILP-20 pin	DP-20N, -20NEV	P	—

Pin Arrangement

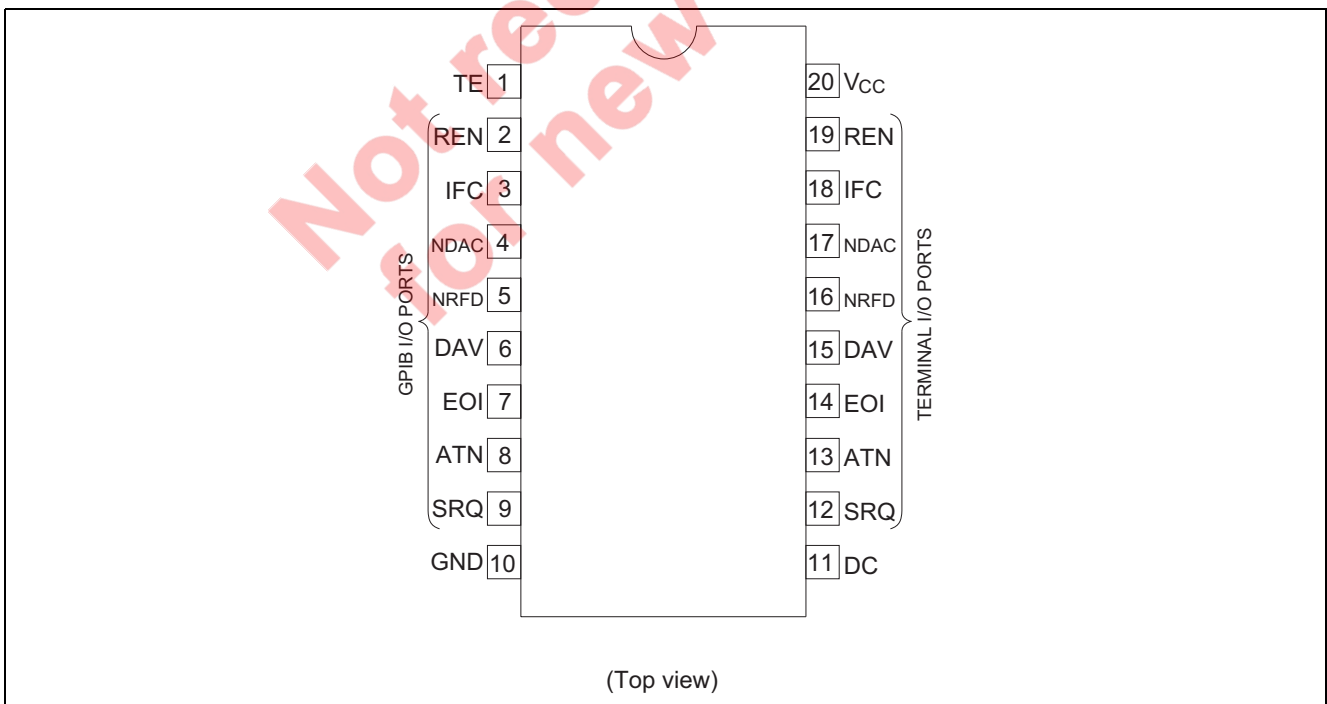

Table Of Abbreviation

DRIVERS		
Name	Identity	Class
DC	Direction Control	Control
TE	Talk Enable	
ATN	Attention	Bus Management
SRQ	Service Request	
REN	Remote Enable	
IFC	Interface Clear	
EOI	End Or Identify	
DAV	Data Valid	
NDAC	Not Data Accepted	Data Transfer
NRFD	Not Ready For Data	

Function Table

Controls			Bus management Channels				Data transfer Channels			
			ATN* ¹	SRQ	REN	IFC	EOI	DAV	NDAC	NRFD
DC	TE	ATN	Controlled By DC				EOI	Controlled by TE		
H	H	H	R	T	R	R	T	T	R	R
H	H	L					R			
L	L	H	T	R	T	T	R	R	T	T
L	L	L					T			
H	L	X	R	T	R	R	R	R	T	T
L	H	X	T	R	T	T	T	T	R	R

- H : High level
- L : Low level
- X : Irrelevant
- R : Receiver
- T : Transmit

- Notes: 1. ATN is a normal transceiver channel that functions additionally as an internal direction control or talk enable for EOI whenever the DC and TE inputs are in the same state.
2. Direction of data transmission is from the terminal side to the bus side and the direction of data receiving is from the bus side to the terminal side. Data transfer is noninverting in both directions.

Absolute Maximum Ratings

Item	Symbol	Rating	Unit
Supply Voltage	V _{CC}	7	V
Input Voltage	V _{IC}	5.5	V
Output Current	I _{OL}	100	mA
Power Dissipation (Ta = 25°C)	P _T	1150	mW
Operating Temperature Range	T _{opr}	0 to 70	°C
Storage Temperature Range	T _{stg}	-65 to +150	°C

- Note: 1. The absolute maximum ratings are values which must not individually be exceeded, and furthermore, no two of which may be realized at the same time.

Recommended Operating Conditions

Item	Symbol	Min	Typ	Max	Unit
Supply Voltage	V_{CC}	4.75	5.00	5.25	V
Output Current	Bus Ports With 3 State Outputs	—	—	-5.2	mA
	Terminal Ports	—	—	-800	μ A
Output Current	Bus Ports With 3 State Outputs	—	—	48	mA
	Terminal Ports	—	—	16	
Operating Temperature	T_{opr}	0	—	70	$^{\circ}$ C

Logic Diagram

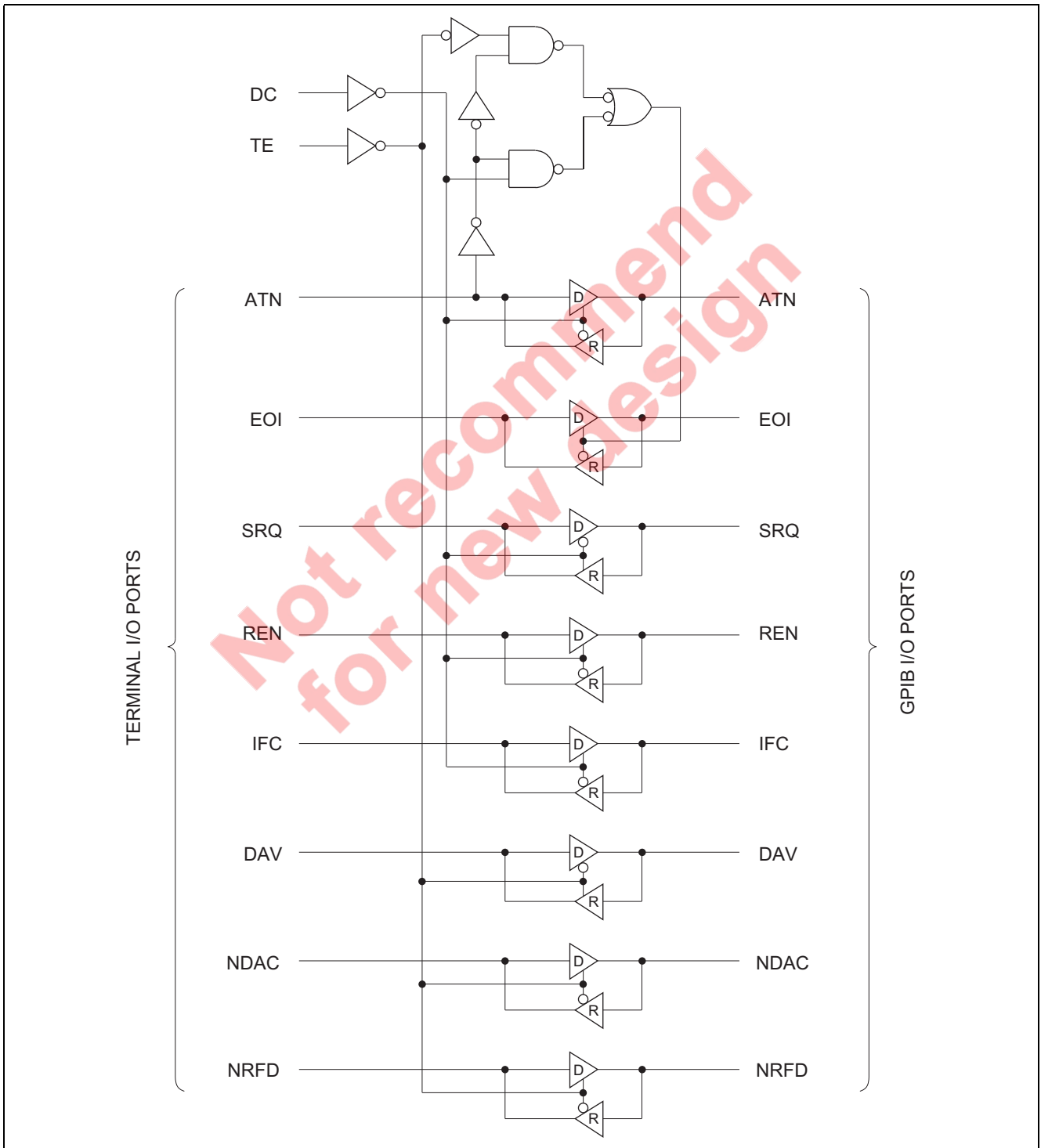

DC Electrical Characteristics (Ta = 0 to 70°C)

Item	Symbol	V _{CC}	Min	Max	Unit	Conditions	
Input Voltage	V _{IH}	2	—	—	V		
	V _{IL}	—	—	0.8			
Input Clamp Voltage	V _{IK}	—	—	-1.5	V	I _I = -18 mA	
Hysteresis	Bus	V _T ⁺ - V _T ⁻	0.4	—	V		
Output Voltage	Terminal	V _{OH}	2.7	—	V	I _{OH} = -800 μA	
	Bus		2.5	—		I _{OH} = -5.2 mA	
	Terminal	V _{OL}	—	0.5	V	I _{OL} = 16 mA	
	Bus		—	0.5		I _{OL} = 48 mA	
Input Current	Terminal	I _I	—	100	μA	V _I = 5.5 V	
	Terminal And Control Inputs	I _{IH}	—	20		V _I = 2.7 V	
		I _{IL}	—	-100		V _I = 0.5 V	
Voltage at Bus Port	V _{I/O (bus)}	2.5	—	3.7	V	Driver I _{I(bus)} = 0	
		—	—	-1.5		Disabled I _{I(bus)} = -12 mA	
Current Into Bus Port	V _{CC} ON	I _{I/O (bus)}	-1.3	—	—	mA	Driver V _{I(bus)} = -1.5 V to 0.4 V
			0	—	-3.2		Disabled V _{I(bus)} = 0.4 V to 2.5 V
			—	—	+2.5		V _{I(bus)} = 2.5 V to 3.7 V
			—	—	-3.2		
			0	—	2.5		V _{I(bus)} = 3.7 V to 5 V
	0.7		—	2.5		V _{I(bus)} = 5 V to 5.5 V	
V _{CC} OFF	—	—	40	μA	V _{CC} = 0, V _{I(bus)} = 0 V to 2.5 V		
Short Circuit Output Current	Terminal	I _{OS}	-15	—	-75	mA	
	Bus		-25	—	-125		
Supply Voltage	I _{CC}	—	—	100	mA	No Load TE, DC, low	
Bus port Capacitance	C _{I/O (bus)}	—	30	—	pF	V _{CC} = 5 V or 0 V, V _{I/O} = 0 to 2 V, f = 1 MHz	

Note: 1. V_{CC} = 5 V, Ta = 25°C

Switching Characteristics (V_{CC} = 5 V, Ta = 25°C)

Item	Symbol	Input	Output	Min	Typ	Max	Unit	Test Circuit	Test Conditions		
Propagation Delay Time	t _{PLH}	Terminal	BUS	—	14	20	ns	1	C _L = 30 pF R _L = 38.3 Ω to 2.3 V		
	t _{PHL}			—	14	20					
	t _{PLH}	BUS	Terminal	—	12	20				2	C _L = 30 pF R _L = 240 Ω to 5 V
	t _{PHL}			—	16	22					
Output Enable Time	t _{ZH}	TE DC	BUS	—	—	60	3	C _L = 15 pF R _L = 480 Ω to 0 V			
Output Disable Time	t _{HZ}		ATTN, EO1	—	—	45					
Output Enable Time	t _{ZL}		REN, IFC and DAY	—	—	60					
Output Disable Time	t _{LZ}		—	—	55	4			C _L = 15 pF R _L = 38.3 Ω to 2.3 V		
Output Enable Time	t _{ZH}	Terminal	—	—	55						
Output Disable Time	t _{HZ}	—	—	50	C _L = 15 pF R _L = 3 kΩ to 0 V						
Output Enable Time	t _{ZL}	—	—	45							
Output Disable Time	t _{LZ}	—	—	55	C _L = 15 pF R _L = 280 Ω to 5 V						

Switching Time Test Method

1. t_{PLH} , t_{PHL}

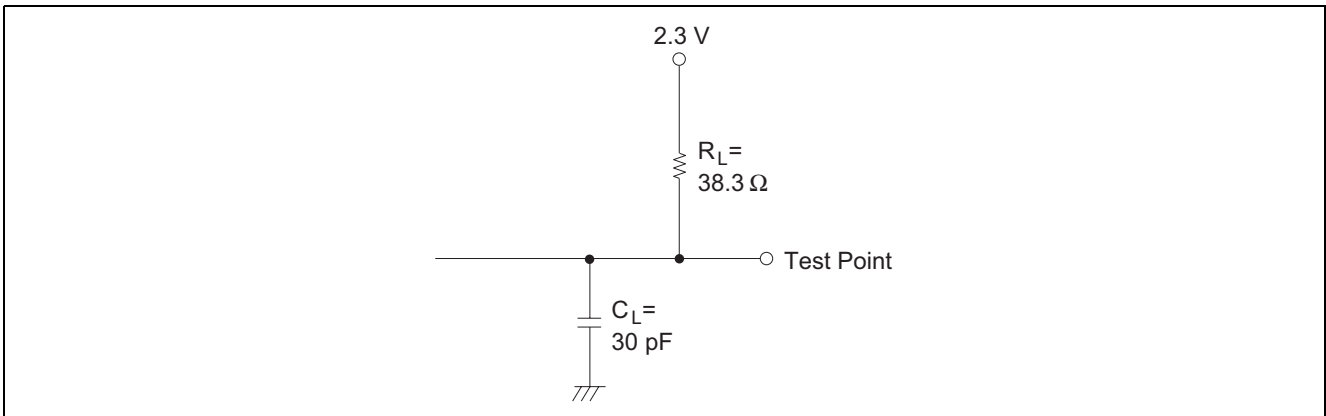

Waveforms-1

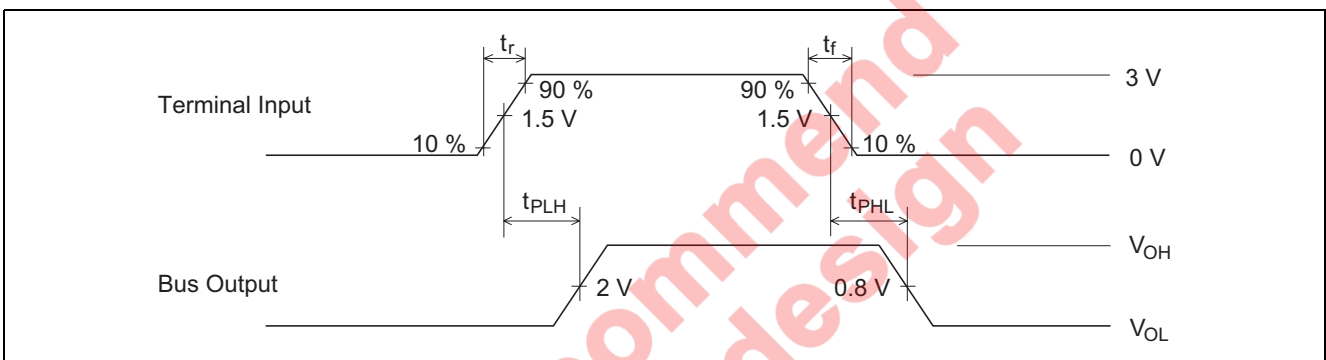

Not recommended for new design

2. t_{PLH} , t_{PHL}

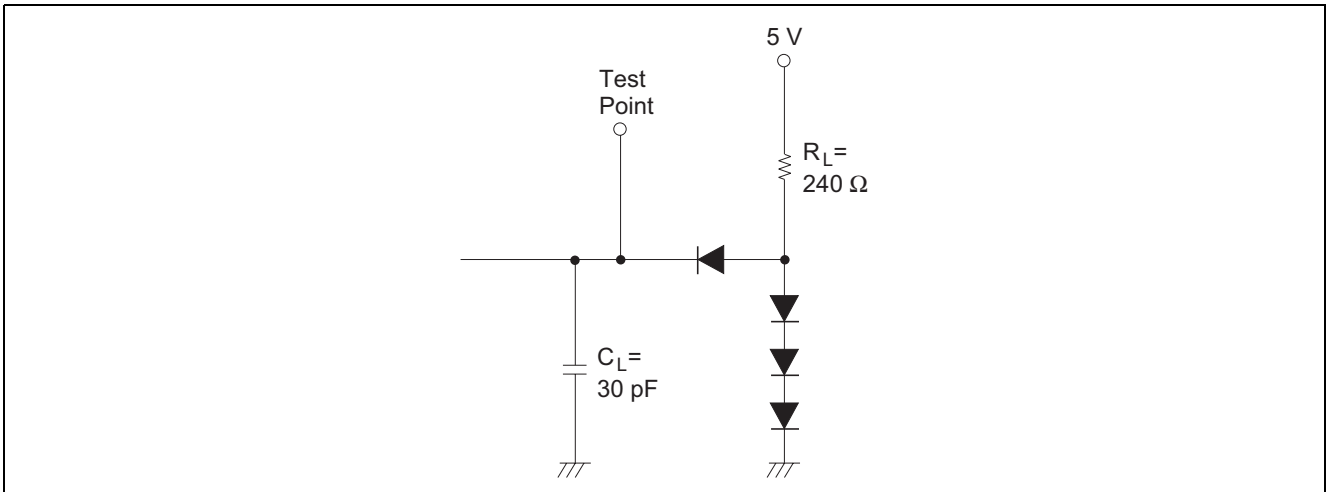

Waveforms-2

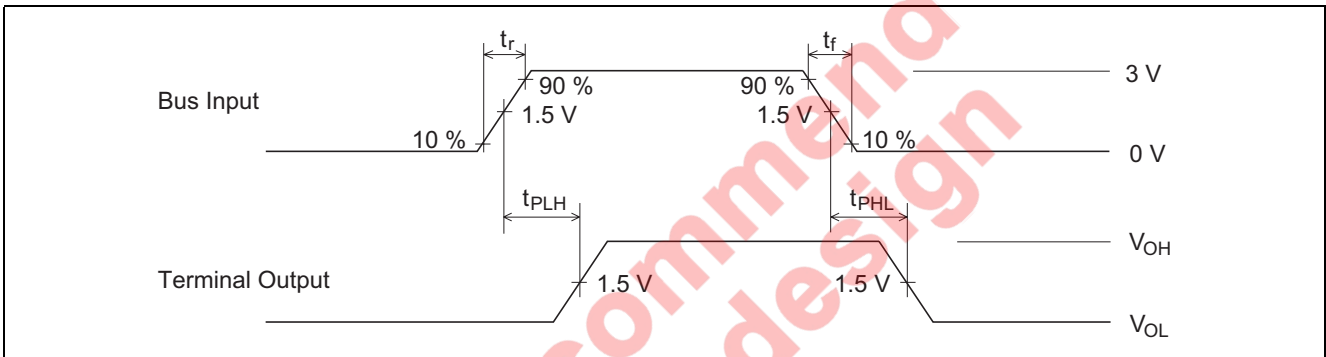

Not recommended for new design

3. t_{ZH} , t_{HZ} , t_{ZL} , t_{LZ}

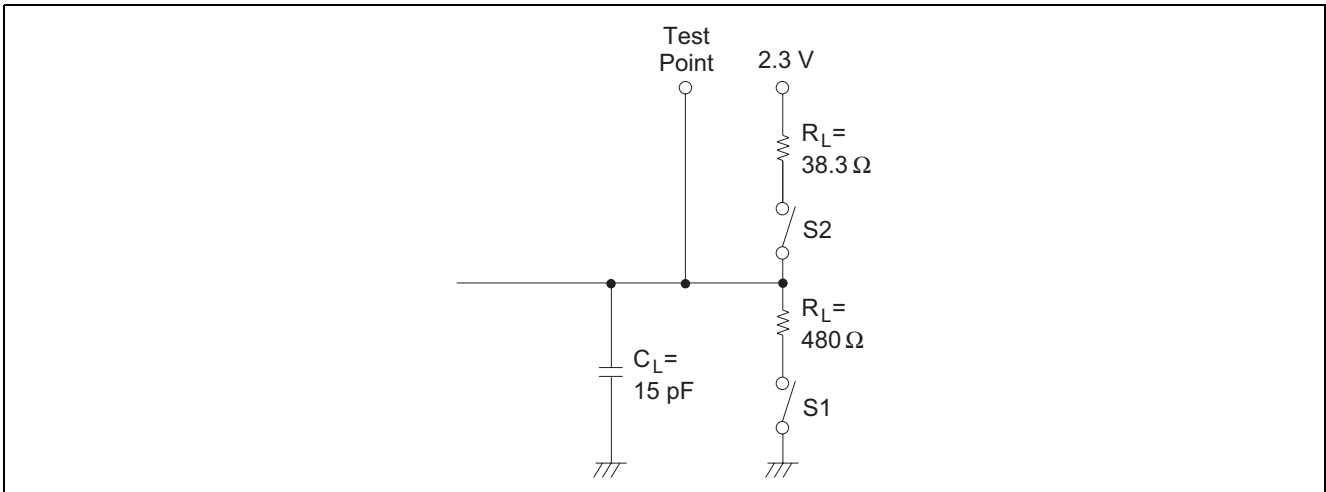

Waveforms-3

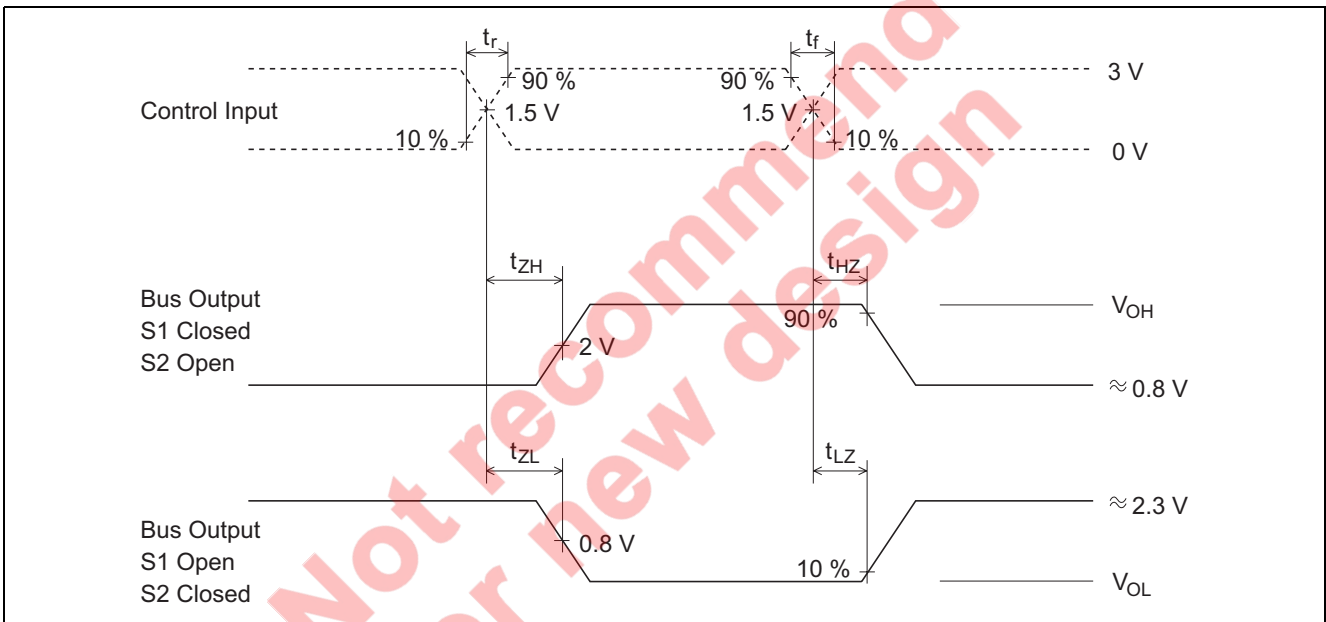

4. t_{ZH} , t_{HZ} , t_{ZL} , t_{LZ}

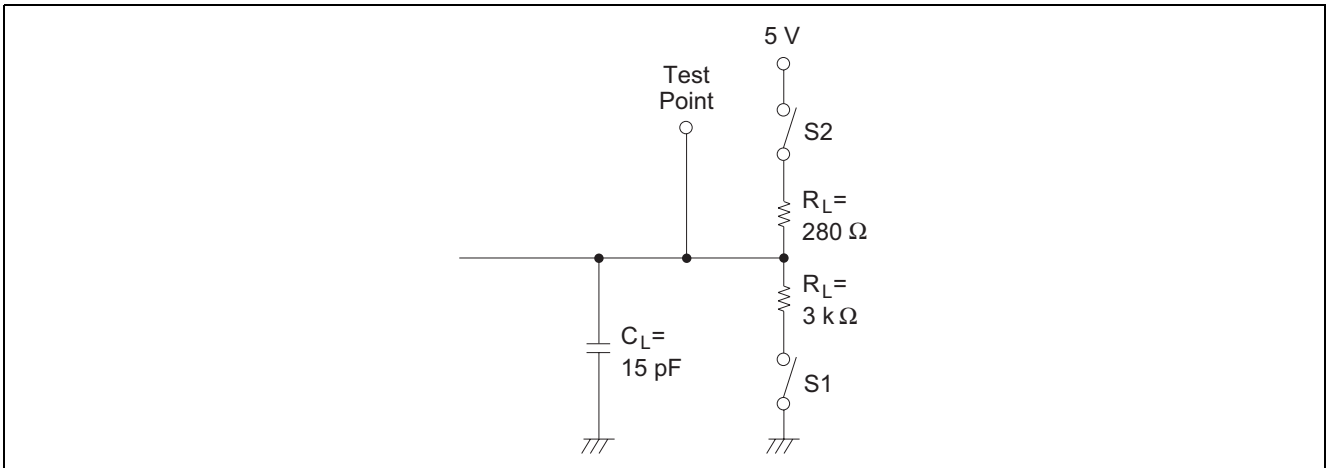

Waveforms-4

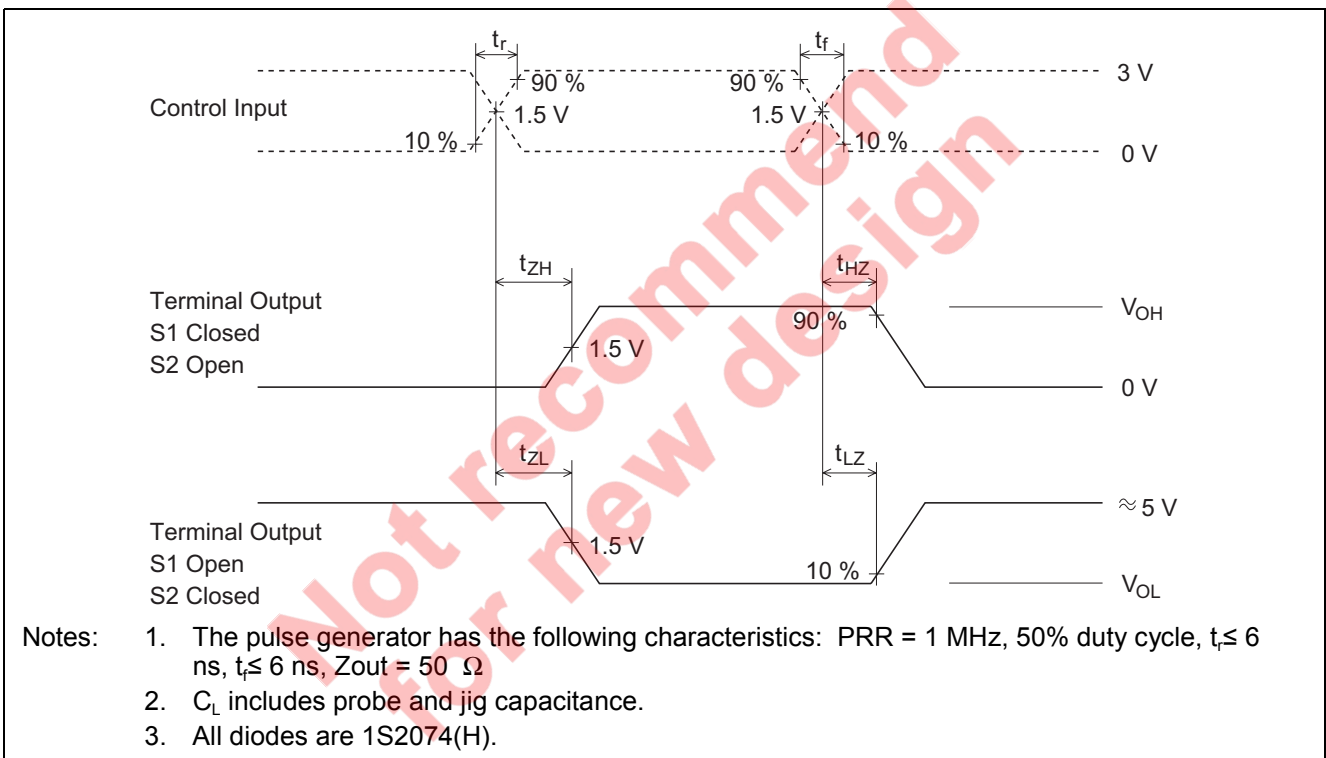

Characteristics Of Driver And Receiver

(a) Driver Output

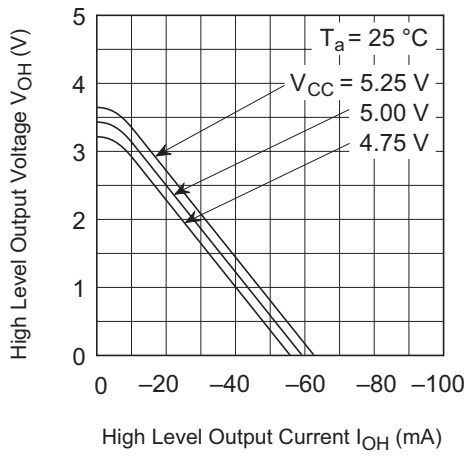

(b) Driver Output

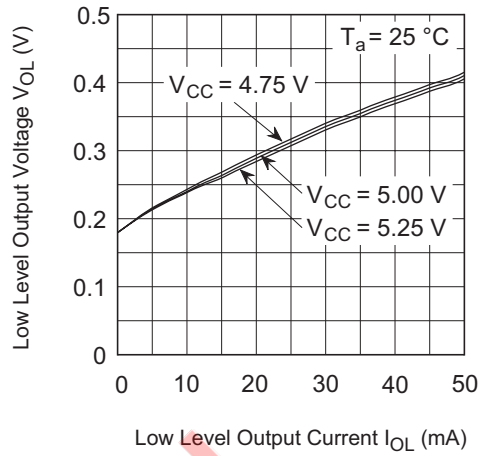

(c) Receiver Output

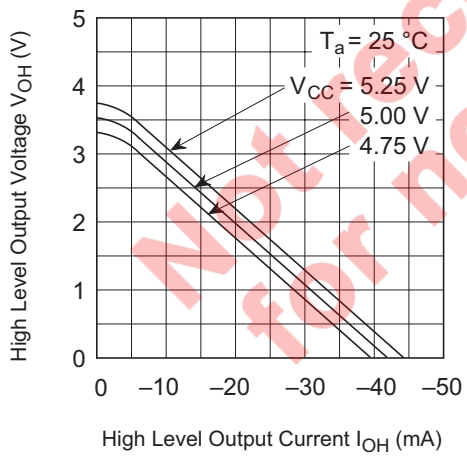

(d) Receiver Output

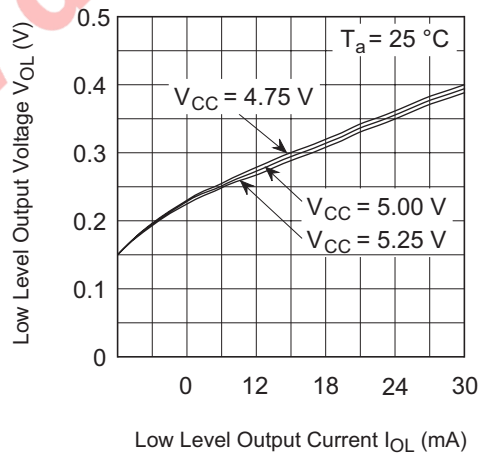

(e) Input / Output Characteristics at Receiver

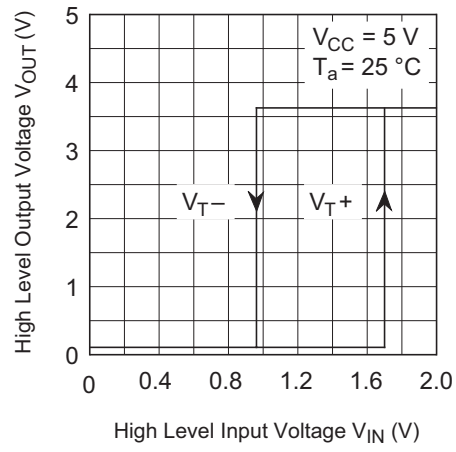

Not recommend
for new design

Package Dimensions

As of January, 2003
Unit: mm

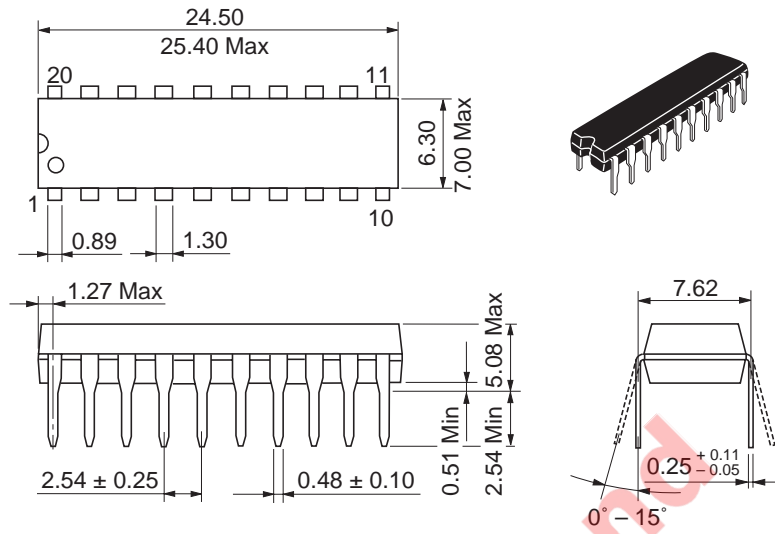

Package Code	DP-20N
JEDEC	—
JEITA	Conforms
Mass (reference value)	1.26 g

Unit: mm

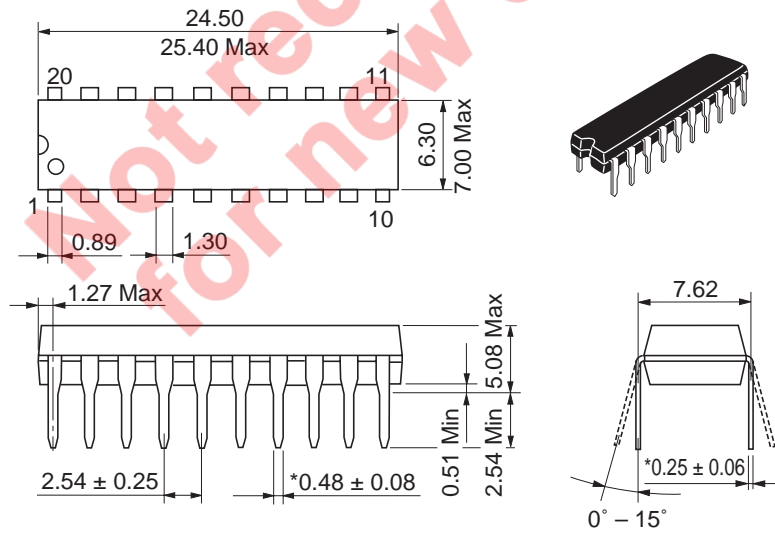

*Ni/Pd/AU Plating

Package Code	DP-20NEV
JEDEC	—
JEITA	Conforms
Mass (reference value)	1.26 g

Keep safety first in your circuit designs!

1. Renesas Technology Corp. puts the maximum effort into making semiconductor products better and more reliable, but there is always the possibility that trouble may occur with them. Trouble with semiconductors may lead to personal injury, fire or property damage. Remember to give due consideration to safety when making your circuit designs, with appropriate measures such as (i) placement of substitutive, auxiliary circuits, (ii) use of nonflammable material or (iii) prevention against any malfunction or mishap.

Notes regarding these materials

1. These materials are intended as a reference to assist our customers in the selection of the Renesas Technology Corp. product best suited to the customer's application; they do not convey any license under any intellectual property rights, or any other rights, belonging to Renesas Technology Corp. or a third party.
 2. Renesas Technology Corp. assumes no responsibility for any damage, or infringement of any third-party's rights, originating in the use of any product data, diagrams, charts, programs, algorithms, or circuit application examples contained in these materials.
 3. All information contained in these materials, including product data, diagrams, charts, programs and algorithms represents information on products at the time of publication of these materials, and are subject to change by Renesas Technology Corp. without notice due to product improvements or other reasons. It is therefore recommended that customers contact Renesas Technology Corp. or an authorized Renesas Technology Corp. product distributor for the latest product information before purchasing a product listed herein.
The information described here may contain technical inaccuracies or typographical errors.
Renesas Technology Corp. assumes no responsibility for any damage, liability, or other loss rising from these inaccuracies or errors.
Please also pay attention to information published by Renesas Technology Corp. by various means, including the Renesas Technology Corp. Semiconductor home page (<http://www.renesas.com>).
 4. When using any or all of the information contained in these materials, including product data, diagrams, charts, programs, and algorithms, please be sure to evaluate all information as a total system before making a final decision on the applicability of the information and products. Renesas Technology Corp. assumes no responsibility for any damage, liability or other loss resulting from the information contained herein.
 5. Renesas Technology Corp. semiconductors are not designed or manufactured for use in a device or system that is used under circumstances in which human life is potentially at stake. Please contact Renesas Technology Corp. or an authorized Renesas Technology Corp. product distributor when considering the use of a product contained herein for any specific purposes, such as apparatus or systems for transportation, vehicular, medical, aerospace, nuclear, or undersea repeater use.
 6. The prior written approval of Renesas Technology Corp. is necessary to reprint or reproduce in whole or in part these materials.
 7. If these products or technologies are subject to the Japanese export control restrictions, they must be exported under a license from the Japanese government and cannot be imported into a country other than the approved destination.
Any diversion or reexport contrary to the export control laws and regulations of Japan and/or the country of destination is prohibited.
 8. Please contact Renesas Technology Corp. for further details on these materials or the products contained therein.
-



RENESAS SALES OFFICES

<http://www.renesas.com>

Renesas Technology America, Inc.

450 Holger Way, San Jose, CA 95134-1368, U.S.A
Tel: <1> (408) 382-7500 Fax: <1> (408) 382-7501

Renesas Technology Europe Limited.

Dukes Meadow, Millboard Road, Bourne End, Buckinghamshire, SL8 5FH, United Kingdom
Tel: <44> (1628) 585 100, Fax: <44> (1628) 585 900

Renesas Technology Europe GmbH

Dornacher Str. 3, D-85622 Feldkirchen, Germany
Tel: <49> (89) 380 70 0, Fax: <49> (89) 929 30 11

Renesas Technology Hong Kong Ltd.

7/F., North Tower, World Finance Centre, Harbour City, Canton Road, Hong Kong
Tel: <852> 2265-6688, Fax: <852> 2375-6836

Renesas Technology Taiwan Co., Ltd.

FL 10, #99, Fu-Hsing N. Rd., Taipei, Taiwan
Tel: <886> (2) 2715-2888, Fax: <886> (2) 2713-2999

Renesas Technology (Shanghai) Co., Ltd.

26/F., Ruijin Building, No.205 Maoming Road (S), Shanghai 200020, China
Tel: <86> (21) 6472-1001, Fax: <86> (21) 6415-2952

Renesas Technology Singapore Pte. Ltd.

1, Harbour Front Avenue, #06-10, Keppel Bay Tower, Singapore 098632
Tel: <65> 6213-0200, Fax: <65> 6278-8001