

HA16117F Series

CMOS Watchdog Timer

REJ03F0142-0300
(Previous: ADE-204-018B)
Rev.3.00
Jun 15, 2005

Description

The HA16117F Series of ICs make a micro-processor (MPU) system fail-safe by monitoring its power supply to detect voltage drops, and monitoring a P-RUN (program running) pulse to detect system crashes. Also referred to as watchdog timers, these devices are essential in systems that aim for high levels of crash protection. Fabricated by a CMOS process, they consume little power and are ideally suited for battery-operated systems.

These ICs are available in versions for industrial and communications equipment and automotive applications, as well as for consumer products.

Functions

- Power-on reset
Sends a $\overline{\text{RES}}$ signal to the MPU for a fixed time at power-on
- Watchdog timer (WDT)
Monitors a P-RUN signal from the MPU and sends the MPU a $\overline{\text{RES}}$ signal if P-RUN departs from a set frequency range
- Auto-reset
Outputs $\overline{\text{RES}}$ signals to the MPU at clocked intervals while P-RUN remains abnormal
- Supply voltage supervision
Outputs a low $\overline{\text{RES}}$ signal if the supply voltage (same as the MPU's V_{CC}) falls below a low threshold level (V_{TL}). The threshold differs for different ICs in the series, allowing designers to choose an IC matching system requirements (see ordering information)

Features

- Low power consumption : Operating (ACC pin low) = 0.5 mW (Typ)
: Standby (ACC pin high) = 0.2 mW (Typ)
- Watchdog timer on/off control by ACC input signal
- Independent auto-reset high and low times (t_{RH} and t_{RL})
- Watchdog monitoring by frequency filtering (independent of duty cycle)
- High-precision low voltage detection ($\pm 2\%$)
- Space- and weight-saving 8-pin SOP package

Ordering Information

The HA16117F Series includes three ICs with different low threshold levels (V_{TL}).

Type No.	Low Threshold Voltage (V_{TL})
HA16117FPA/FPAJ	4.4 V Typ
HA16117FPB/FPBJ	4.2 V Typ
HA16117FPC/FPCJ	4.0 V Typ

Pin Arrangement

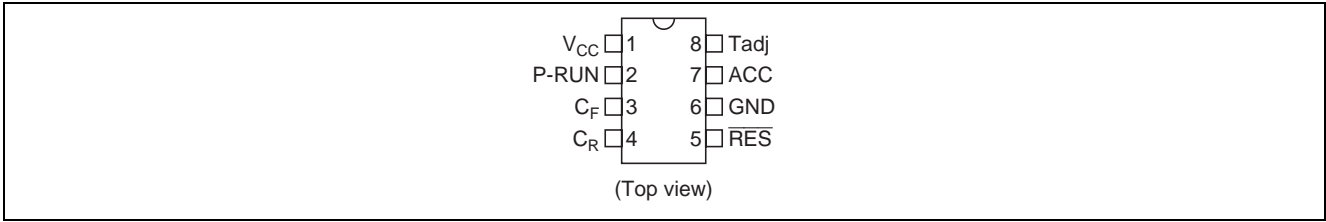

Pin Description

Pin No.	Symbol	Function
1	V _{CC}	Power supply voltage input
2	P-RUN	Watchdog timer (WDT) input
3	C _F	Connected capacitor C _F determines WDT filter characteristic (normal frequency range)
4	C _R	Connected capacitor C _R determines t _{ON} for power-on reset and t _{OFF} , t _{RH} , and t _{RL} for auto-reset
5	RES	Reset signal output from WDT and voltage supervision circuits
6	GND	Ground
7	ACC	WDT on/off control input (on when ACC is low)
8	Tadj *	For adjusting t _{RH} and t _{OFF} (divide V _{CC} to get the adjustment voltage)

Note: The low-voltage threshold cannot be modified by changing the external resistors connected to the Tadj pin.

Not recommended for new designs

Block Diagram

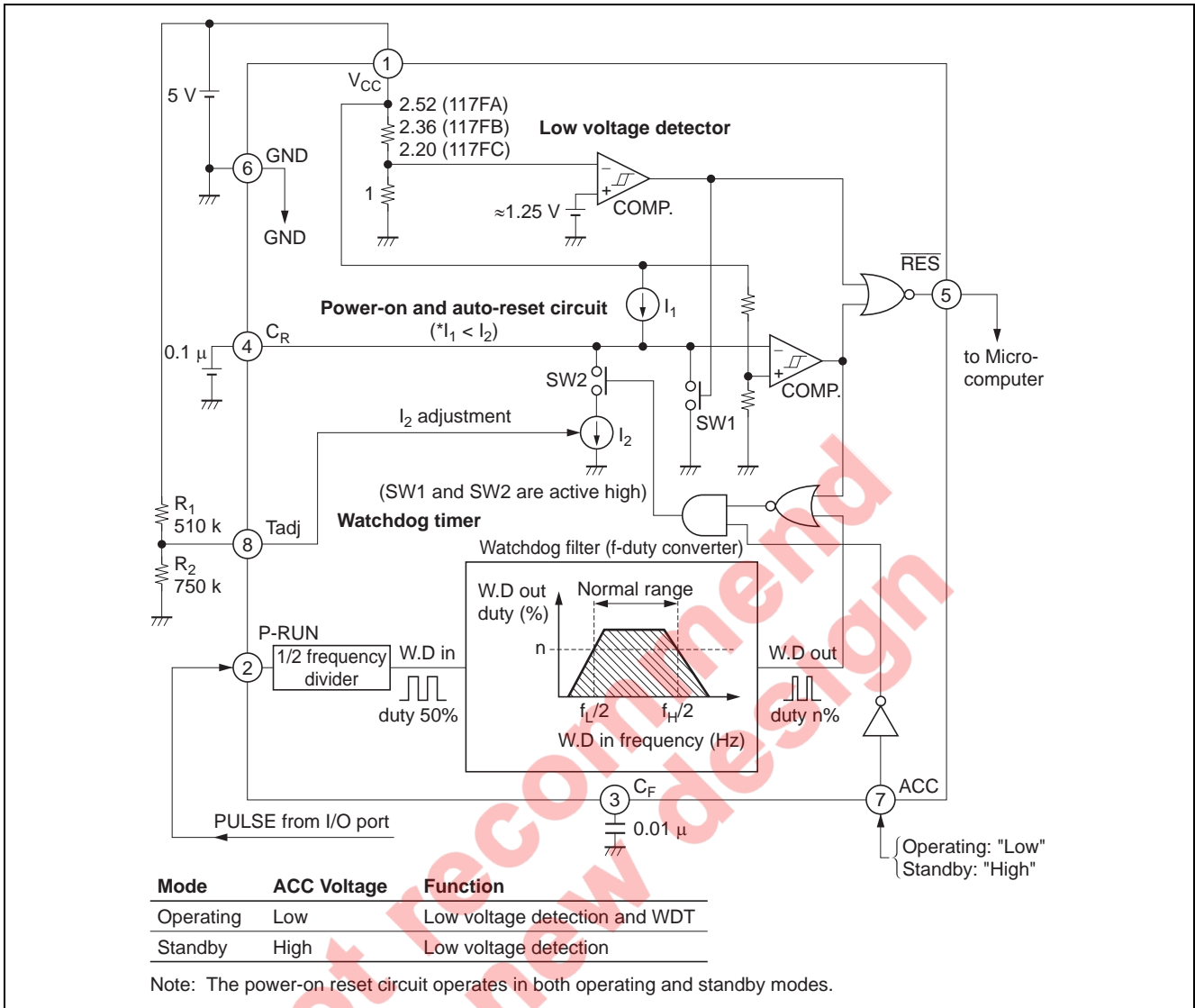

The HA16117F consists of a low voltage detector, power-on and auto-reset circuit, and watchdog timer.

Low Voltage Detector

Uses a reference voltage source ($\approx 1.25\text{ V}$) and high-precision comparator to detect drops in the supply voltage.

Power-On and Auto-Reset Circuit

Generates the $\overline{\text{RES}}$ waveform, using a multivibrator consisting of a current source I_1 that charges the external capacitor C_R , a current source I_2 that discharges C_R , and a comparator.

Watchdog Timer

Reshapes the P-RUN signal (programming-running pulse) from the MPU to obtain a 50% duty cycle, then converts frequency to duty cycle in the watchdog filter (WD filter).

The watchdog filter is a bandpass filter. The duty cycle of the filter output is highest in the normal frequency range of P-RUN.

The watchdog filter output controls I_2 in the multivibrator, the higher the duty cycle of the watchdog filter output, the shorter the time during which I_2 discharges C_R . If the duty cycle is high enough then C_R is held at a high potential, preventing the multivibrator from firing, and the $\overline{\text{RES}}$ output remains high.

Absolute Maximum Ratings

(Ta = 25°C)

Item	Symbol	Ratings		Unit
		HA16117FPA/FPB/FPC	HA16117FPAJ/FPBJ/FPCJ	
Power supply voltage	V _{CC}	-0.3 to +14	-0.3 to +14	V
P-RUN input voltage	V _P	V _{CC}	V _{CC}	V
ACC input voltage	V _{ACC}	14	14	V
RES output current	I _{RES}	10	10	mA
Permissible dissipation *1	P _T	300	300	mW
Operating temperature range	T _{opr}	-30 to +85	-40 to +85	°C
Storage temperature	T _{stg}	-55 to +125	-55 to +125	°C

Note: 1. This is the value when mounted on a glass epoxy substrate with 30% wiring density, up to an ambient temperature of 83°C. Above that temperature, derate by 7.14 mW/°C.

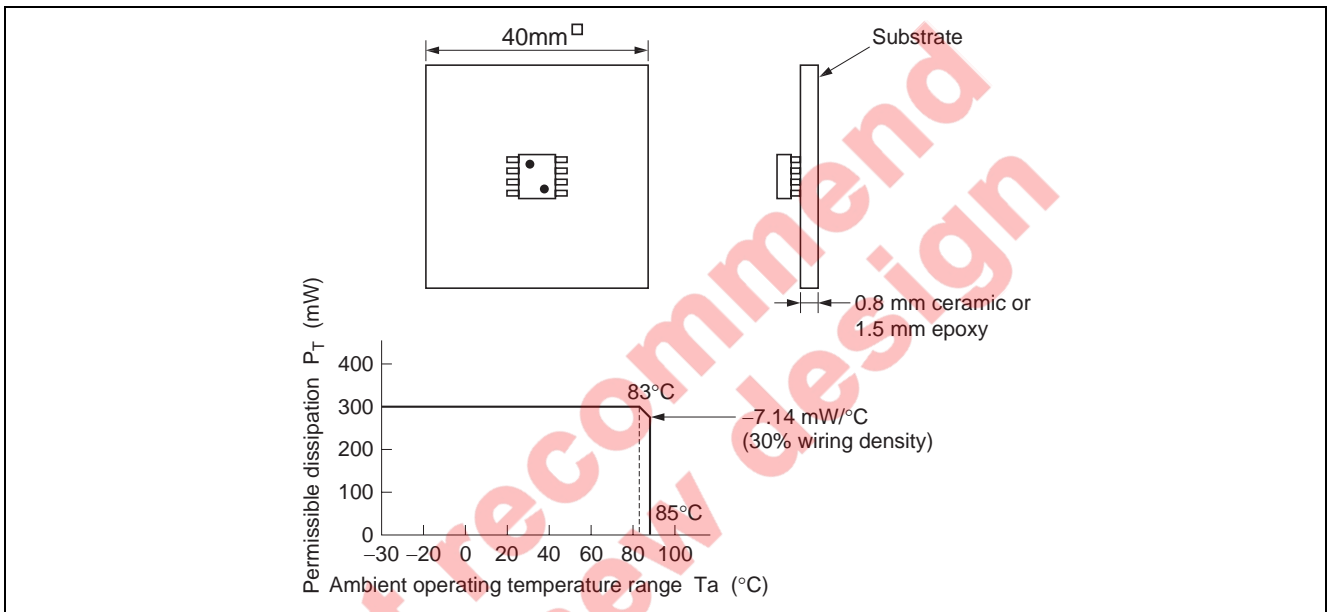

Electrical Characteristics

($V_{CC} = 5\text{ V}$, $T_a = 25^\circ\text{C}$, $C_F = 0.01\ \mu\text{F}$, $C_R = 0.1\ \mu\text{F}$, $R_1 = 510\ \text{k}\Omega$, $R_2 = 750\ \text{k}\Omega$)

Item		Symbol	Min	Typ	Max	Unit	Test Conditions	
General	Operating supply current	I_{CC1}	–	100	–	μA	$V_{ACC} = 0\text{ V}$, $f_{P-RUN} = 100\text{ Hz}$	
		I_{CC2}	–	200	600	μA	$V_{ACC} = 0\text{ V}$, $f_{P-RUN} = 20\text{ kHz}$	
	Standby supply current	I_{STBY}	–	43	100	μA	$V_{ACC} = 12\text{ V}$	
Low voltage detector	Low voltage threshold level	HA16117FPA/FPAJ	V_{TL}	4.3	4.4	4.5	V	When V_{CC} drops 
		HA16117FPB/FPBJ		4.1	4.2	4.3	V	
		HA16117FPC/FPCJ		3.9	4.0	4.1	V	
	Hysteresis width	V_{HYS}	50	100	150	mV		
ACC	Low input voltage	V_{IL1}	–	–	0.8	V		
	High input voltage	V_{IH1}	2.0	–	–	V		
P-RUN input	Low input voltage	V_{IL2}	–	–	0.8	V		
	High input voltage	V_{IH2}	2.0	–	–	V		
WDT	Power-on reset time	t_{ON}	24	40	56	ms		
	Reset-clock off time	t_{OFF}^{*1}	78	130	182	ms		
	Reset low time	t_{RL}	12	20	28	ms		
	Reset high time	t_{RH}	36	60	84	ms	P-RUN pin = 0 V	
	Low setup time	t_{SL}	1	–	–	ms		
	High setup time	t_{SH}	–	–	1	ms		
RES output	$\overline{\text{RES}}$ low voltage	V_{OL}	–	–	0.4	V	$I_{OL} = 1\text{ mA}$	
	$\overline{\text{RES}}$ high voltage	V_{OH}	–	V_{CC}	–	V	Open	
	Reset function starting voltage	V_{RES}	–	0.8	1.4	V		
Constant range	Constant range of R_1 and R_2	K	0.55	0.6	0.8	–	$K = R_2 / (R_1 + R_2)$	
Operating supply voltage range		V_{CCRNG}	V_{TL}	–	6.0	V		

Note: 1. Reset-clock off time t_{OFF} is provided as shown in the under figure.

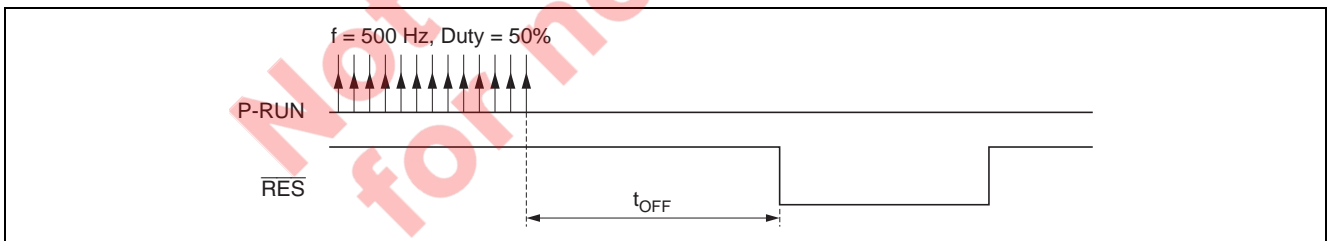

Timing Waveforms and Functional Description

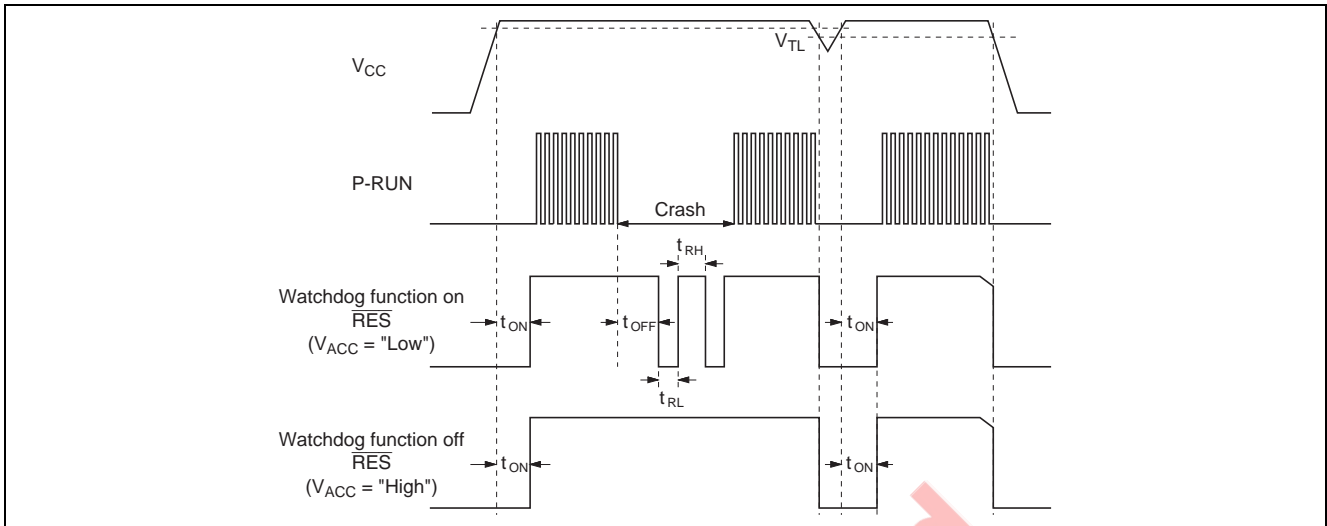

Figure 1 Timing Waveforms

Watchdog On/Off Function

A feature of the HA16117F is that watchdog supervision can be switched on and off. When the watchdog function is switched on, both the supply voltage and

P-RUN input are monitored to detect abnormal conditions. When the watchdog function is switched off (standby mode), only the supply voltage is monitored. Watchdog supervision is switched on and off by the input at the ACC pin (pin 7): Supervision is on when ACC is low, and off when ACC is high.

Many MPUs have a standby mode in which the CPU stops running but memory contents are retained. In standby mode, program execution halts and I/O ports go to the high-impedance state, so there is no need for the watchdog timer to supervise pulse output from an I/O port to detect abnormal conditions. Power can be saved by placing both the MPU and HA16117F in standby mode at the same time. The HA16117F is designed to draw a typical standby current I_{STBY} of only 43 μ A Typ when the watchdog function is switched off.

ACC Pin (pin 7) and $\overline{\text{RES}}$ Output

When the MPU returns from standby mode to normal operation it generally takes 10 to 200 ms for the clock oscillator in the MPU to stabilize. The $\overline{\text{RES}}$ signal is not output during this setup time. After the setup time (t_{SL}) has elapsed, $\overline{\text{RES}}$ is output if the P-RUN signal from the MPU is still abnormal.

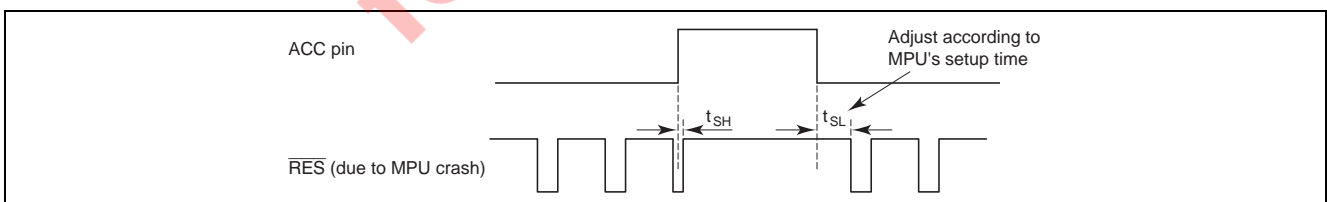

Figure 2 ACC Pin and $\overline{\text{RES}}$ Output

Internal Operation and Usage Notes

Figure 3 shows an equivalent circuit of the watchdog timer block with a V_{CC} pin level of 5 V and ACC pin level of 0 V, and the following pages show internal operation timing charts for different P-RUN frequencies. (Descriptions apply to conditions $C_F = 0.01 \mu\text{F}$, $C_R = 0.1 \mu\text{F}$, $R_2/(R_1 + R_2) = 0.6$.)

Operation

The power-on and auto-reset circuit is a multivibrator with timing controlled by C_R charge current I_1 and discharge current I_2 . As $I_1 : I_2 \approx 3 : 1$ (Typ design value), when the (WD) (watchdog filter circuit output) on-duty is 25% or above, the C_R pin potential does not fall below 1.6 V. Therefore, (C) in the figure below is fixed low, and $\overline{\text{RES}}$ is not output. The (WD) on-duty varies according to the P-RUN frequency. If the frequency is lower or higher than the design value, the (WD) on-duty decreases, and at 25% or below, $\overline{\text{RES}}$ is output. Refer to the timing charts on the following pages for an explanation of the operation of the watchdog filter.

Usage Notes

- When the P-RUN frequency reaches 20 kHz or above, t_{OFF} is short (see the timing charts on the following pages). This must be borne in mind in the design stage.
- If the P-RUN frequency fluctuates, $\overline{\text{RES}}$ may also be output within the normal detection set frequency (see the timing charts on the following pages).
- Detection frequencies f_H and f_L described in the Data Book are Typ values, and a certain amount of dispersion can be expected. A margin of $\pm 30\%$ or more should be allowed for in the design.

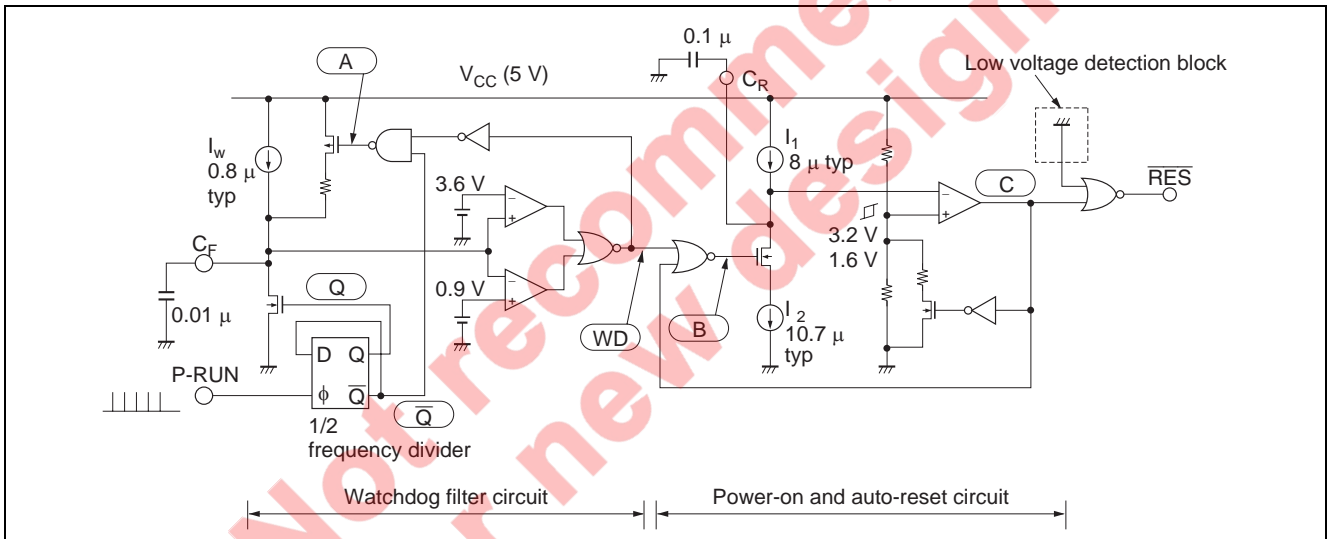
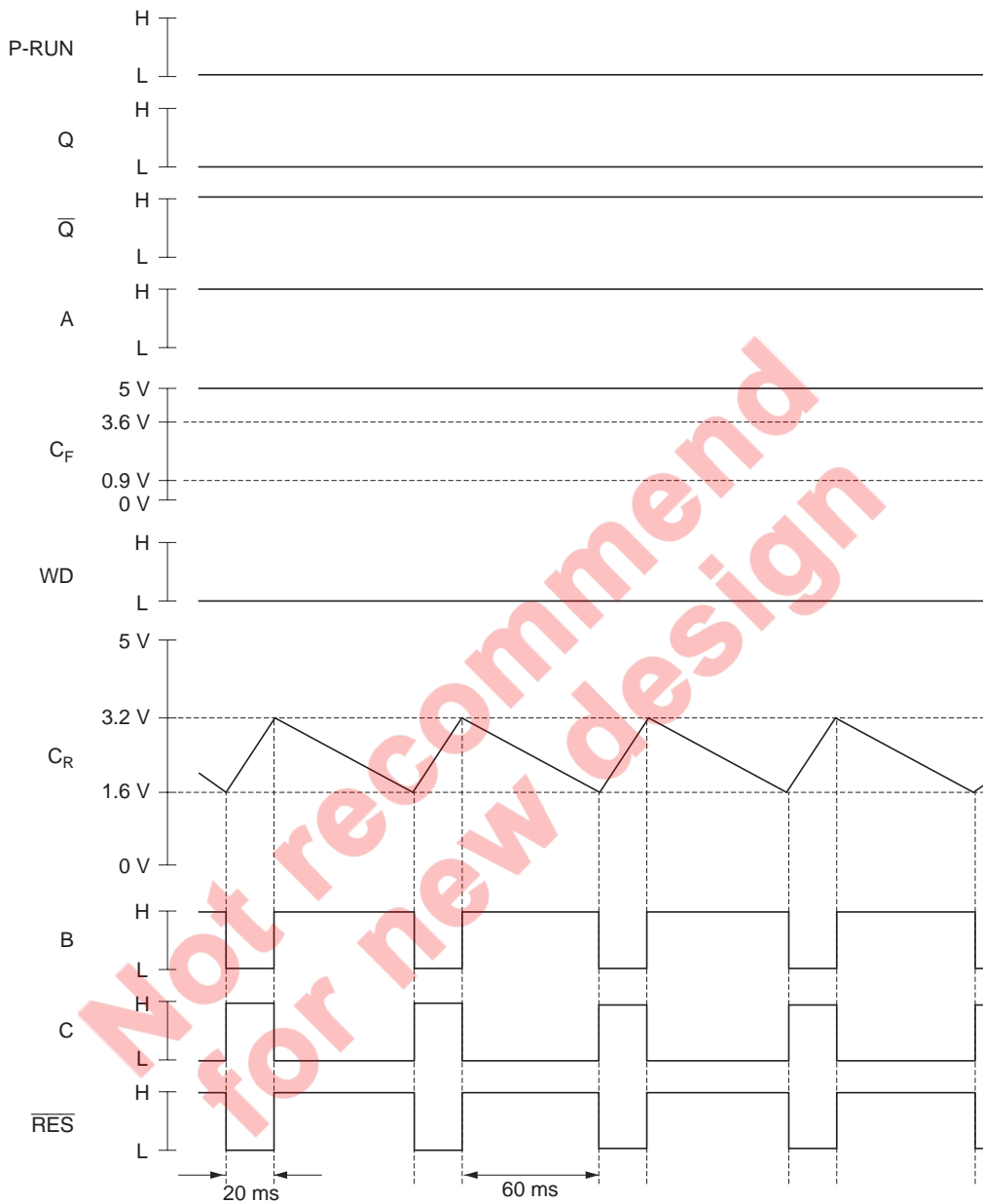

Figure 3 Watchdog Timer Evaluation Circuit

1. When P-RUN signal is not input

The watchdog filter circuit output (WD) is fixed low, so the $\overline{\text{RES}}$ signal is output as shown in the figure below in accordance with power-on and auto-reset circuit C_R charge/discharge.



2. With a low-frequency P-RUN signal (≈ 13 Hz to 26 Hz)

When f_{P-RUN} is 13 Hz to 26 Hz, the WD duty ($D = 100 \times t_2/2T$) is 25% to 50%. When the WD duty is 25% or above, multivibrator (power-on and auto-reset circuit) oscillation stops. As a result, the \overline{RES} signal is fixed high.

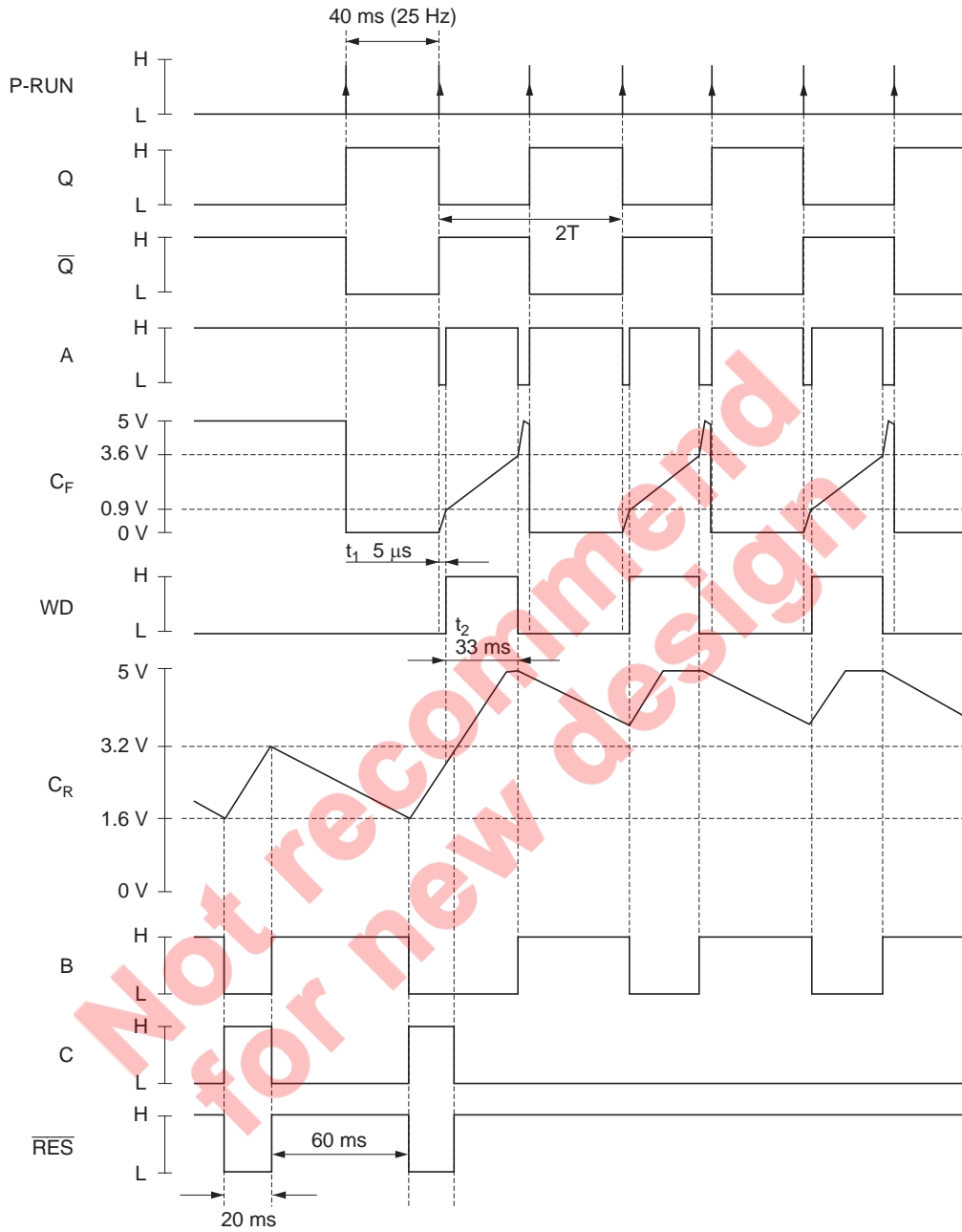

3. With a 10 kHz P-RUN signal

When f_{P-RUN} is 10 kHz, the WD duty ($D = 100 \times (T - t_2)/2T$) is 48%. As the duty is above 25%, the multivibrator (power-on and auto-reset circuit) does not oscillate. The \overline{RES} signal remains high.

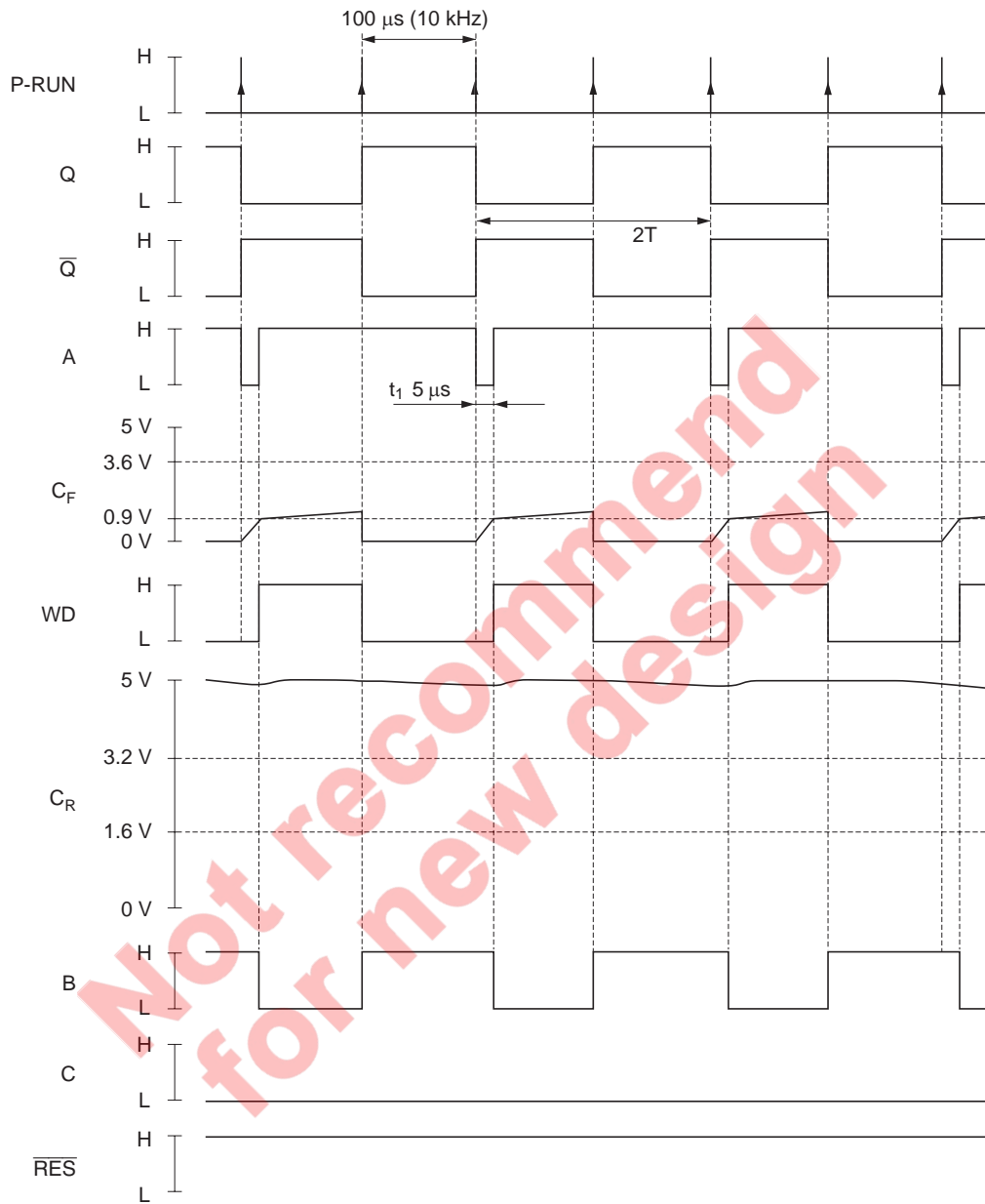

4. With a 150 kHz P-RUN signal

When f_{P-RUN} is 100 kHz or above, the WD duty ($D = 100 \times (T - t_2)/2T$) is 25% or below. Therefore, C_R is discharged, and the \overline{RES} signal is output at the instant that the pin potential falls to the comparator circuit threshold value ($V_{TL} = 1.6\text{ V}$).

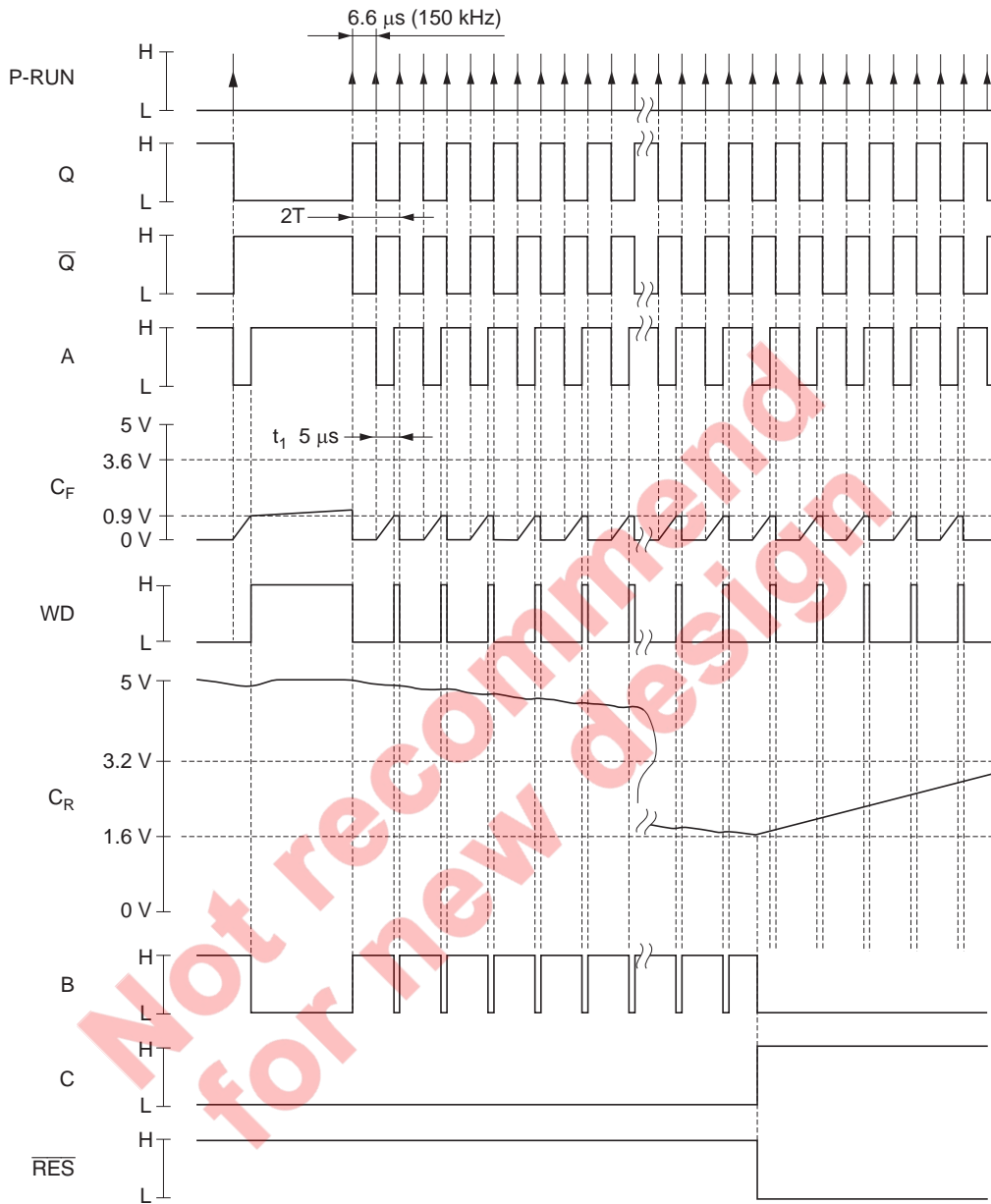

5. t_{OFF} when P-RUN signal ≈ 90 kHz

When the P-RUN frequency is high, even though within specification, the C_R pin potential falls. If the P-RUN frequency falls sharply at this time, t_{OFF} may be short. With values of $C_F = 0.01 \mu\text{F}$ and $C_R = 0.1 \mu\text{F}$, the C_R pin potential will not fall as long as the P-RUN frequency is 20 kHz or below.

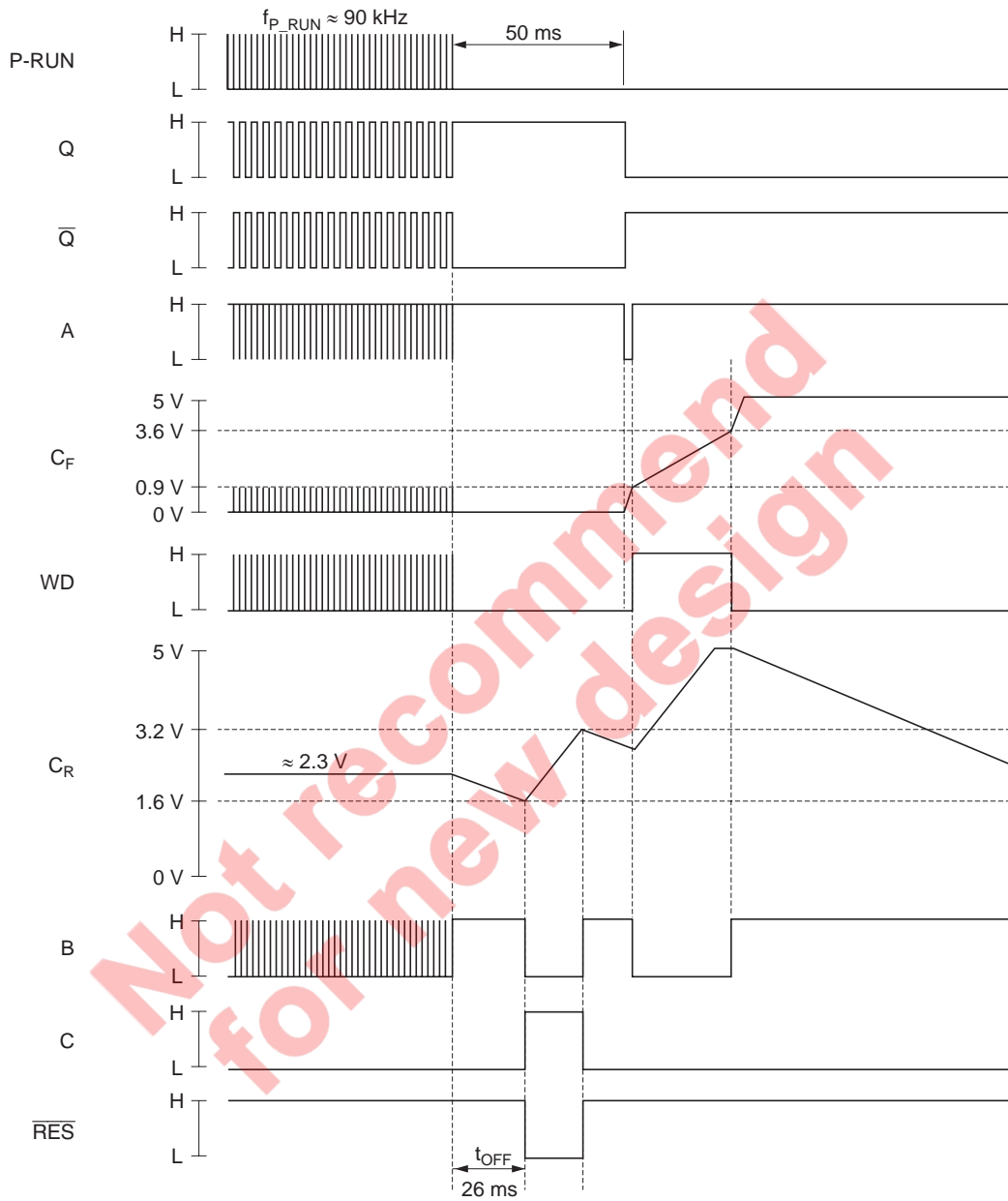

6. When P-RUN frequency fluctuates (1)

If there is a double-pulse in P-RUN, the WD filter duty will be decreased and $\overline{\text{RES}}$ will be output, as shown in the figure below, for example. In this case, the condition for non-output of the $\overline{\text{RES}}$ signal is a value of 3 or less for the ratio of P-RUN pulse interval minimum value to maximum value (when $f_{\text{P-RUN}} \leq 20 \text{ kHz}$). This is because the C_{R} pin charge/discharge current ratio is 3.

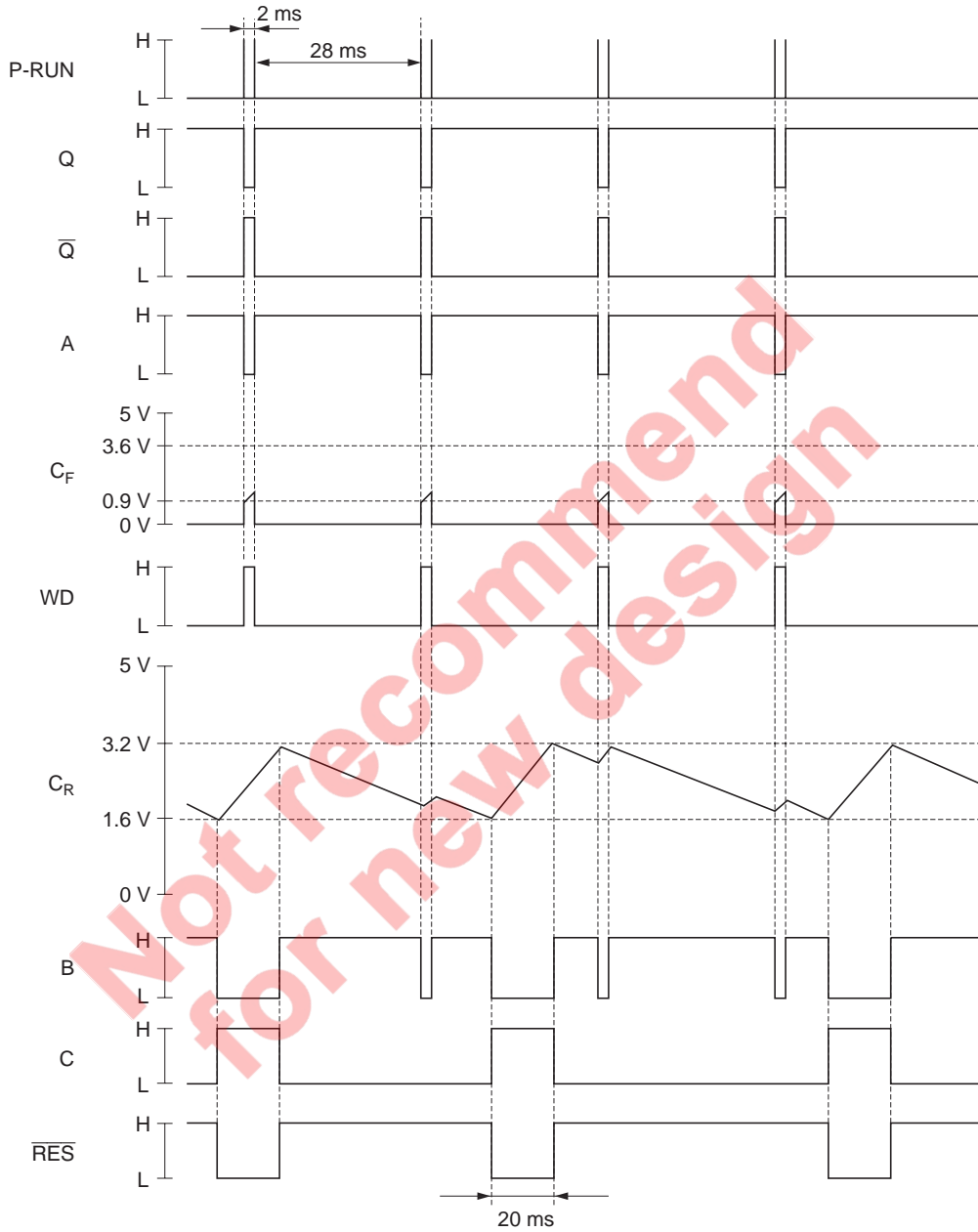

7. When P-RUN frequency fluctuates (2)

If there is a double-pulse in P-RUN, $\overline{\text{RES}}$ will not be output as long as the ratio of P-RUN pulse interval minimum value to maximum value is 3 or less. The timing chart for a P-RUN minimum interval of 8 ms and maximum interval of 22 ms is shown below.

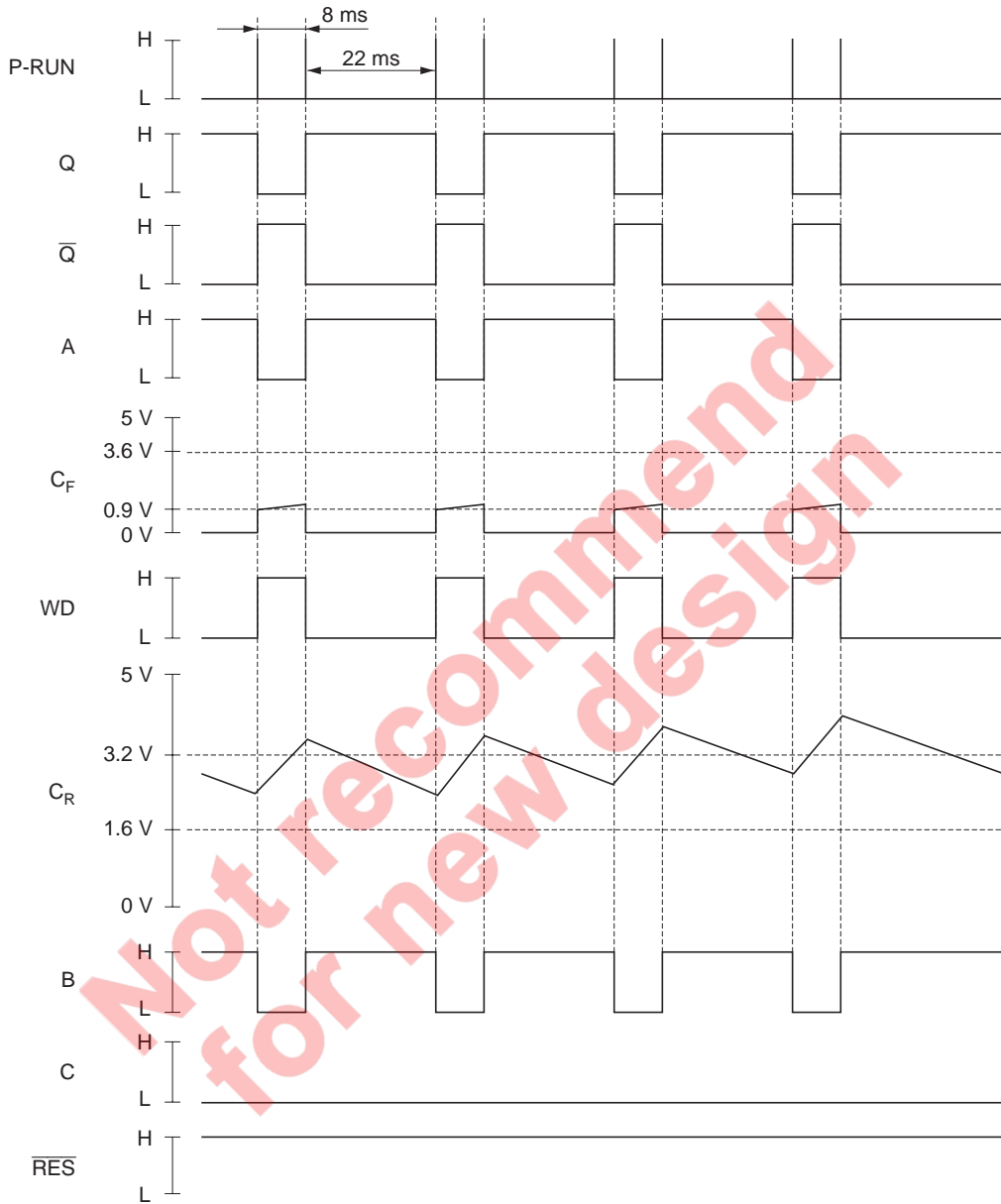

8. Summary of cases where P-RUN frequency fluctuates

If there is a double-pulse in P-RUN, \overline{RES} may be output if the double-pulse has multiple frequency components. If the P-RUN frequency fluctuates, refer to the following when making the P-RUN setting.

- P-RUN normal detection region, duty dependency

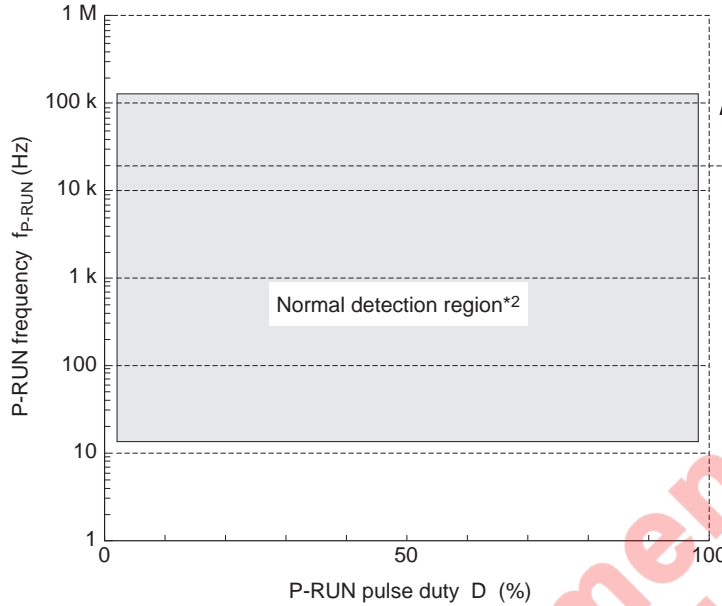

Note: 1
When $f_{P-RUN} \geq 20$ kHz, t_{OFF} is frequency-dependent, so care is required when making the P-RUN setting (see figure below).

Note: 2. This is the region when f_{P-RUN} is constant.
If f_{P-RUN} fluctuates within the normal detection region, the following applies:
Normal detection is performed when the condition $f_{P-RUN H}/f_{P-RUN L} < M$ is satisfied.

- f_{P-RUN} dependency of V_{CR} , t_{OFF} , M

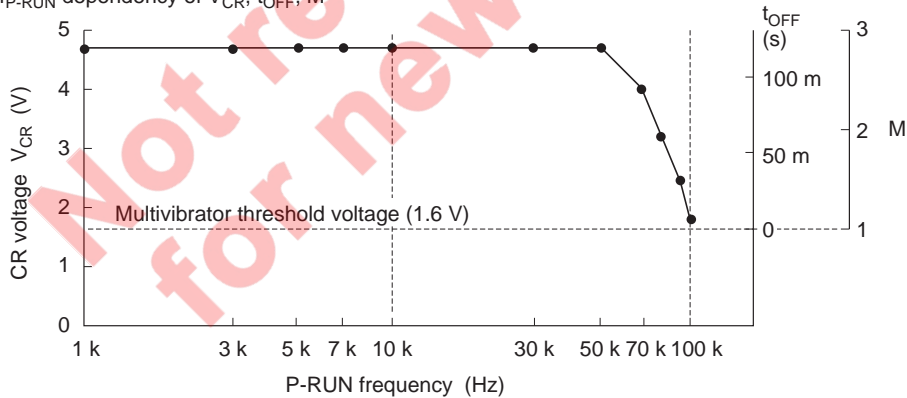

Setting of $\overline{\text{RES}}$ Timing and Watchdog Frequency Range

Different MPUs have different $\overline{\text{RES}}$ timing requirements. The minimum reset time (t_{ON}) required at power-on (rise of V_{CC}) is 20 ms for some MPUs and 100 ms for others.

$\overline{\text{RES}}$ timing waveform parameters must be selected according to the MPU. With the HA16117F the timing of the $\overline{\text{RES}}$ output and the watchdog frequency range can both be set by external constants (C_F , C_R , and K).

Item	Symbol	Parameters		
		CR (pin 4)	CF (pin 3)	K (pin 8) *1
Power-on reset time	t_{ON}	●		
Reset-clock off time	t_{OFF}	●	▲ *2	●
Reset low time	t_{RL}	●		
Reset high time	t_{RH}	●		●
Watchdog frequency high	f_{H}		●	●
Watchdog frequency low	f_{L}	●	●	●

Notes: 1. $K = R_2 / (R_1 + R_2)$

2. Variability of t_{OFF} increases with increasing C_F . The variability Δt_{OFF} is approximately $3.3 \text{ (M}\Omega) \times C_F \text{ (}\mu\text{F)}$, so $C_F \leq 0.01 \text{ (}\mu\text{F)}$ is recommended.

3. External constants should be selected with reference to the formulas in tables 1 and 2.

Table 1 Calculation of $\overline{\text{RES}}$ Output Timing

Item	Formula	Notes
t_{ON} (ms)	$400 \text{ (}\Omega) \times C_R \text{ (}\mu\text{F)}$	t_{ON} and t_{OFF} can be set independently
t_{OFF} (ms)	$1.99 \times t_{\text{RH}}$ (ms)	
t_{RL} (ms)	$0.5 \times t_{\text{ON}}$ (ms)	t_{RL} and t_{RH} can be set independently
t_{RH} (ms)	$\frac{1.6 \text{ (V)}}{K \times 31 \text{ (}\mu\text{A)} - 15.8 \text{ (}\mu\text{A)}} \times C_R \text{ (}\mu\text{F)} \times 10^3$	
t_{SL} (ms)	$\approx t_{\text{OFF}}$ (ms)	

Table 2 Calculation of Watchdog Frequency Range

Item	Formula
f_{H} (MHz)	$\frac{1}{500 \text{ (}\Omega) \times C_F \text{ (}\mu\text{F)}} \times \frac{t_{\text{RH}} \text{ (ms)} - t_{\text{RL}} \text{ (ms)}}{t_{\text{RH}} \text{ (ms)} + t_{\text{RL}} \text{ (ms)}}$
f_{L} (Hz)	$\frac{1}{1.7 \text{ (M}\Omega) \times C_F \text{ (}\mu\text{F)}} \times \frac{t_{\text{RL}} \text{ (ms)}}{t_{\text{RH}} \text{ (ms)} + t_{\text{RL}} \text{ (ms)}}$ or $\frac{1}{t_{\text{OFF}} \text{ (ms)}} \times 10^3$ Whichever is larger

Selection of External Constants

If the reset duration necessary for the MPU to operate reliably at power-on is known, there is a simple procedure for selecting external constants, starting from the power-on reset time (t_{ON}).

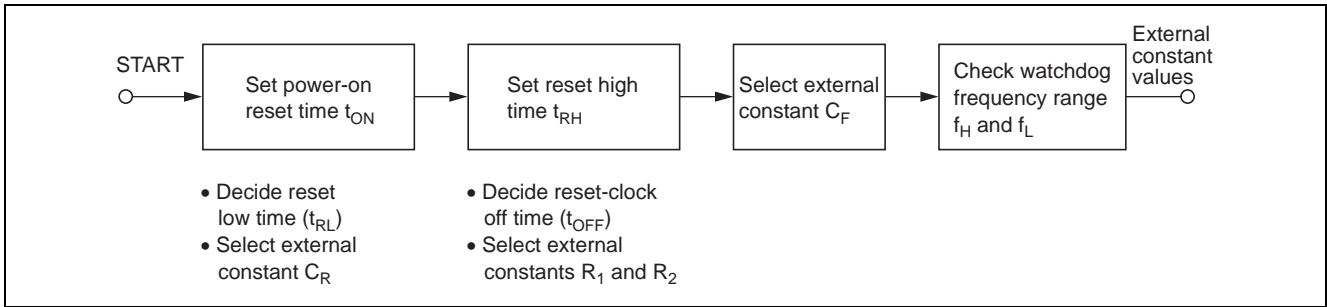
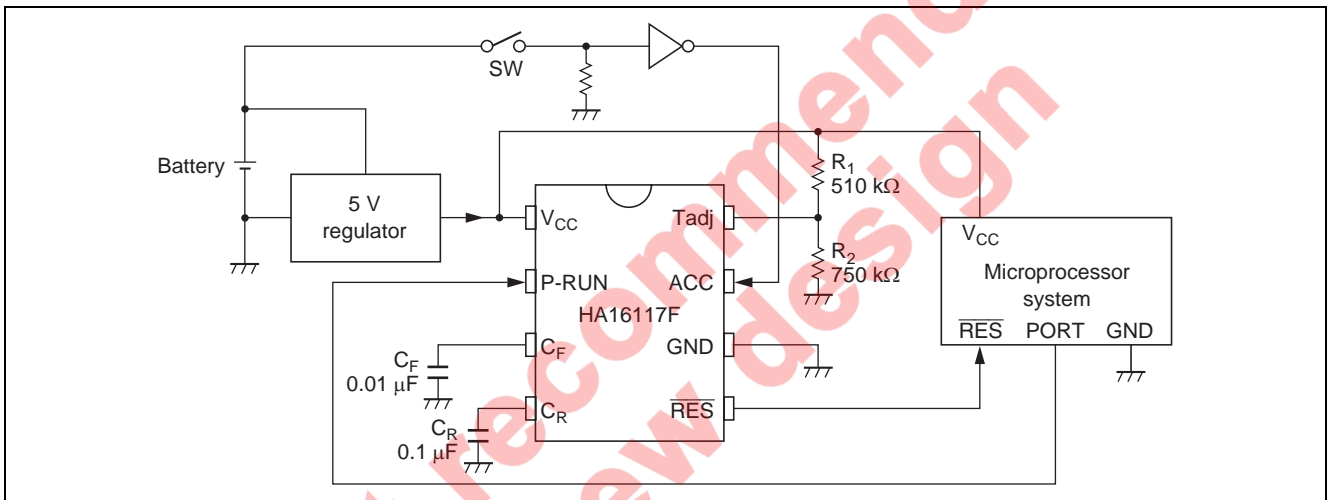
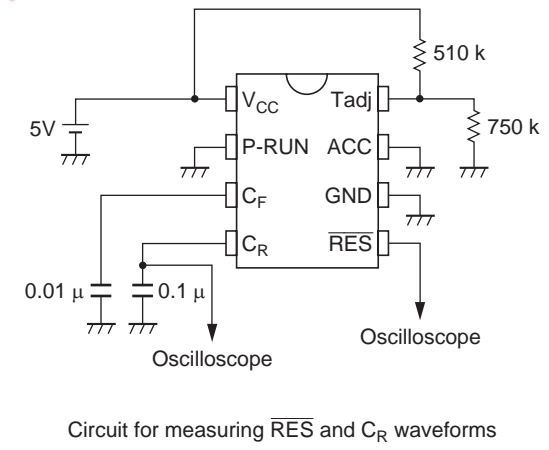
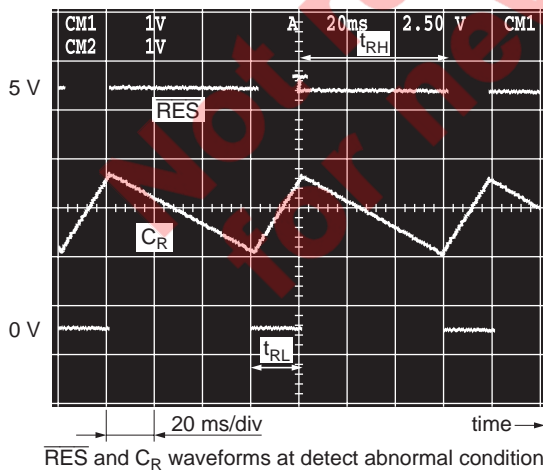
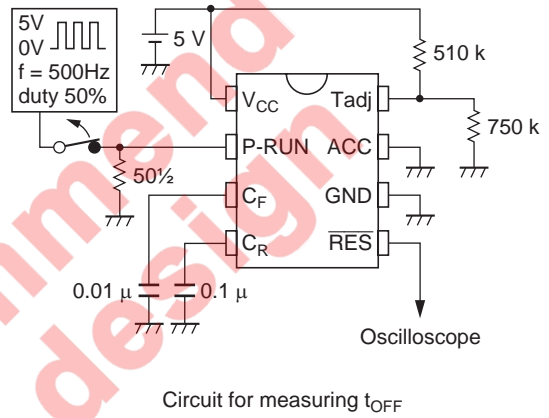
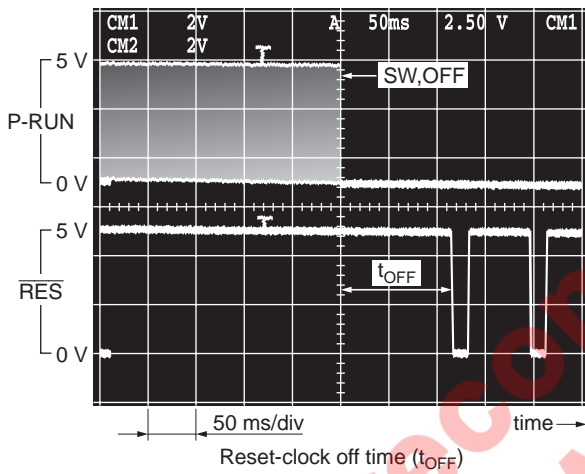
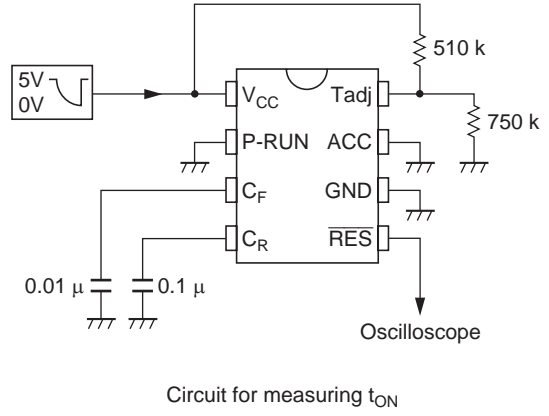
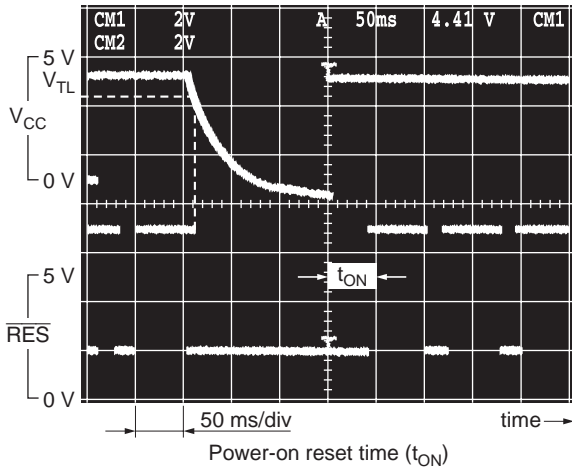

Figure 4 Procedure for Selecting External Constants

Application Example



Operating Characteristics and Test Circuits



Low Voltage Threshold vs. Ambient Temperature

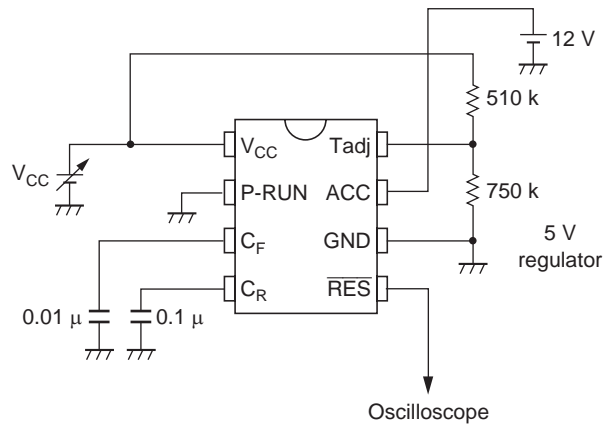
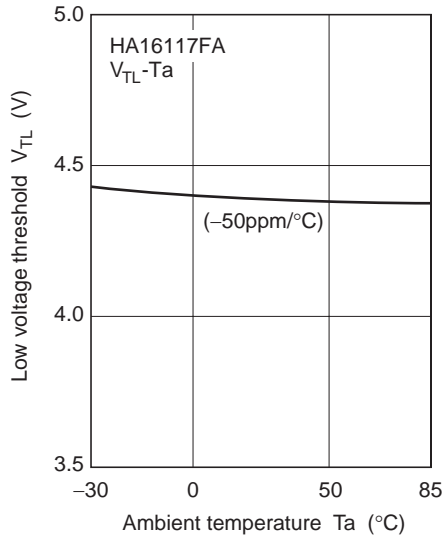

Test circuit

Threshold Hysteresis Width vs. Ambient Temperature

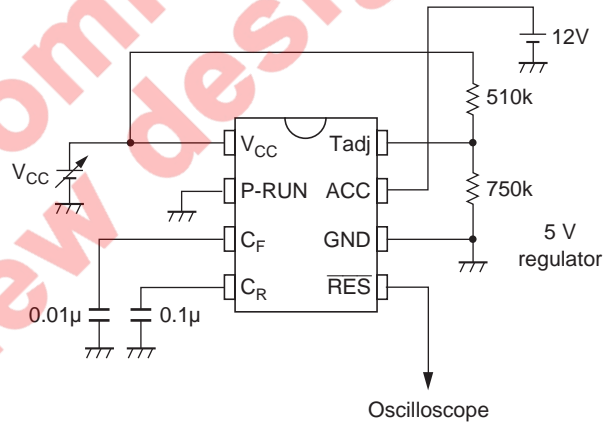
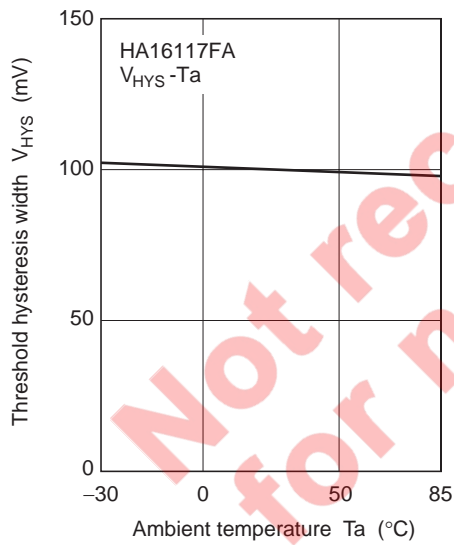

Test circuit

Operating Supply Current vs. P-RUN Input Frequency

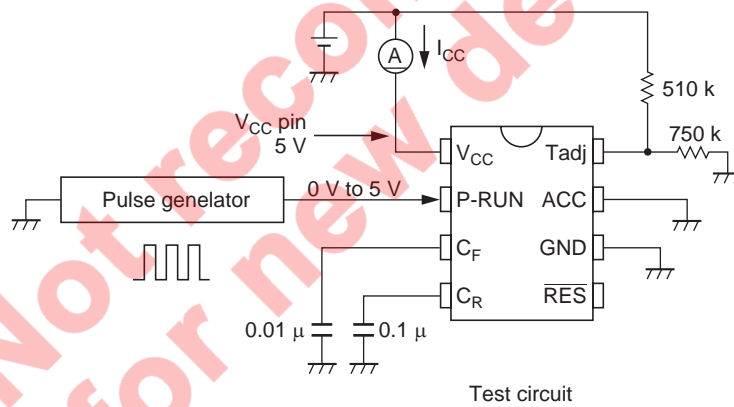
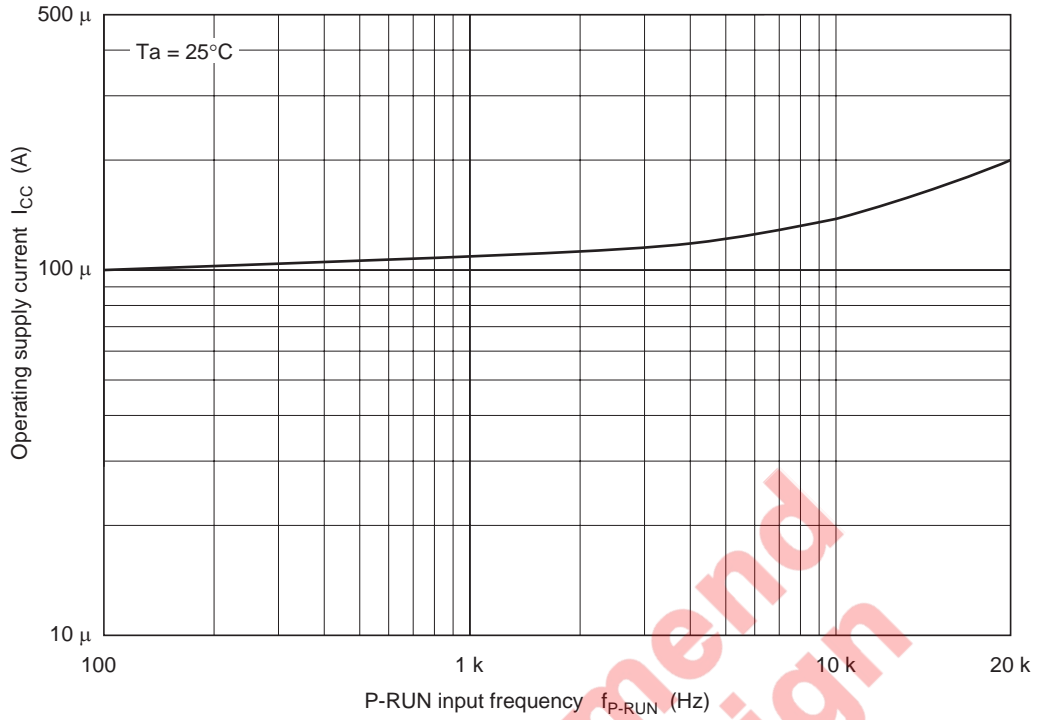

Standby Supply Current vs. Supply Voltage

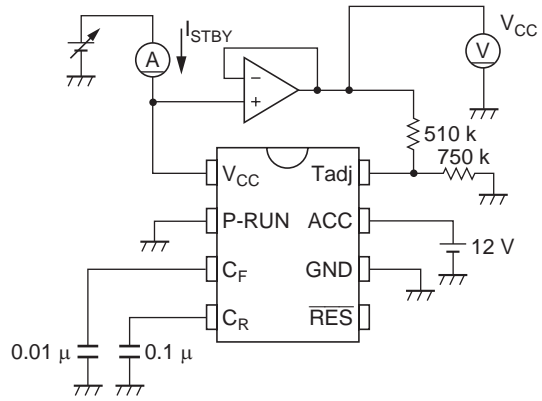
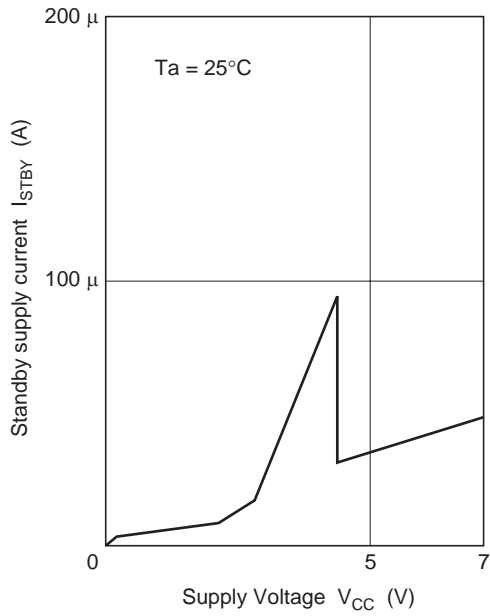

Test circuit

Supply Current vs. Ambient Temperature

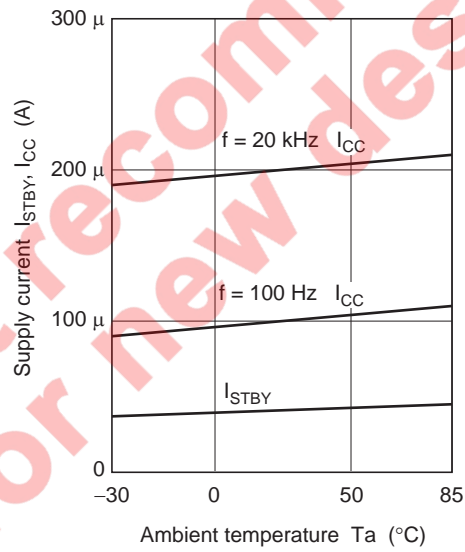

$\overline{\text{RES}}$ Low Voltage vs. $\overline{\text{RES}}$ pin Sink Current

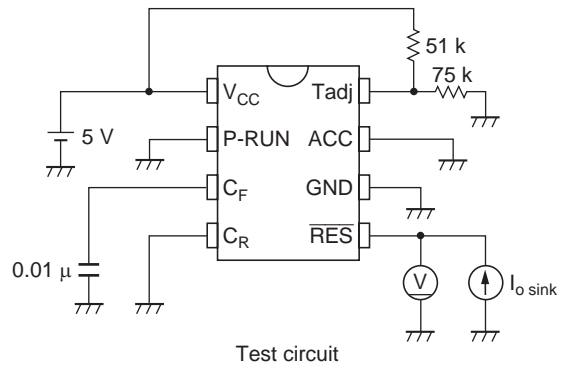
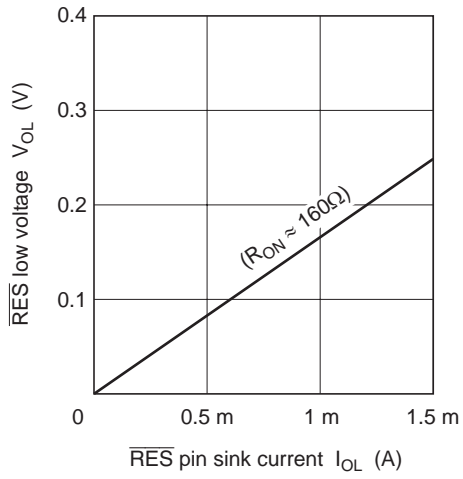

$\overline{\text{RES}}$ Low Voltage vs. Ambient Temperature

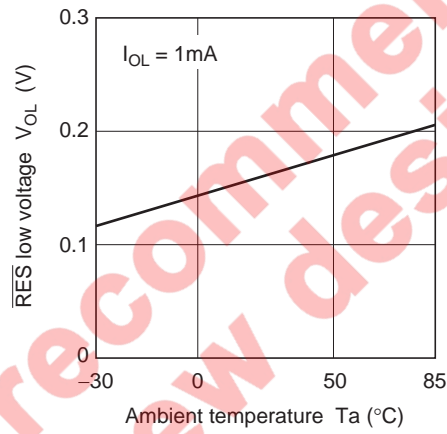

Not recommended for new design

RES High Voltage vs. RES pin Source Current

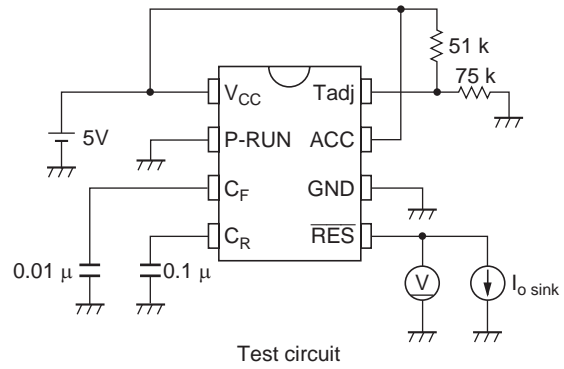
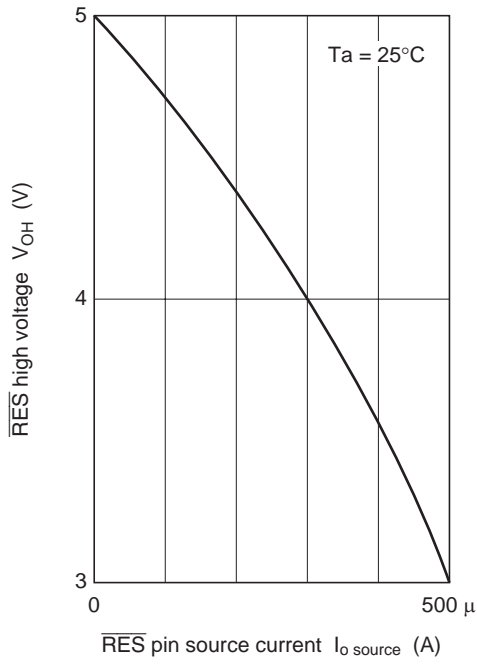

Not recommend
for new design

Power-on Reset Time vs. C_R Capacitance

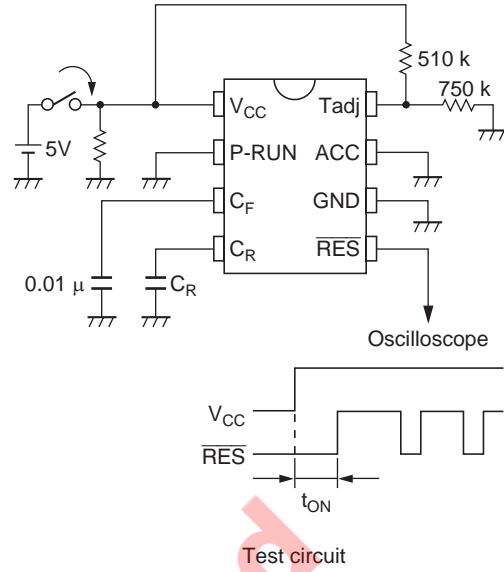
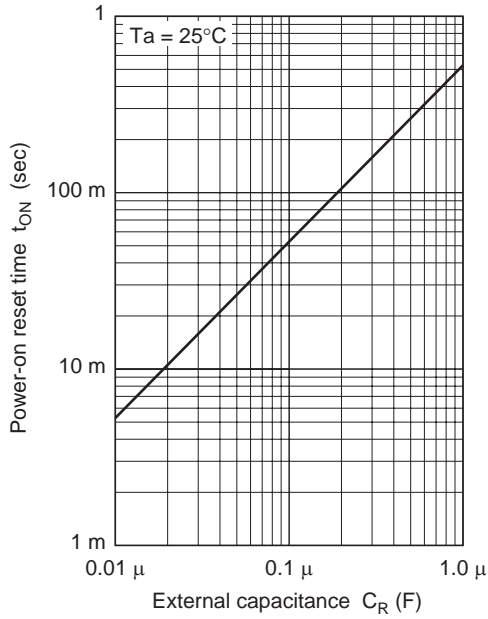

$\overline{\text{RES}}$ Output Timing vs. C_R Capacitance

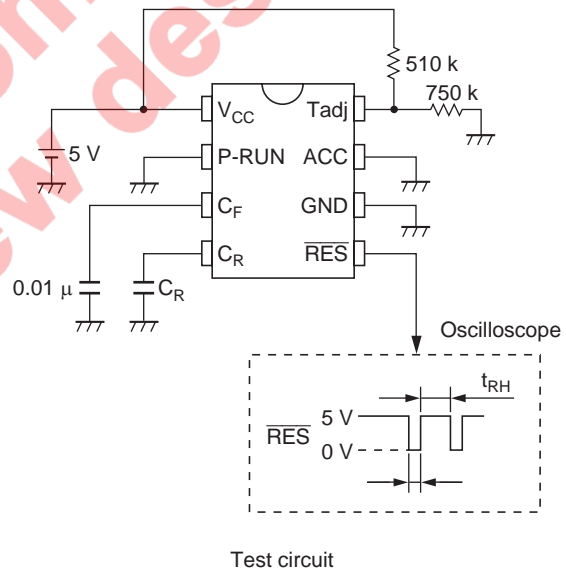
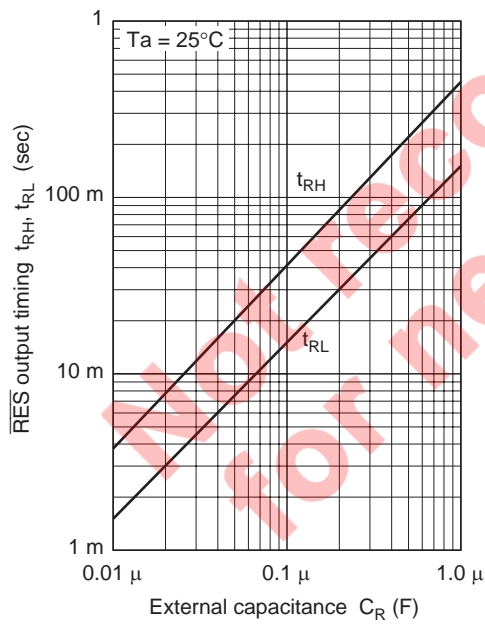

High Setup Time vs. C_R Capacitance

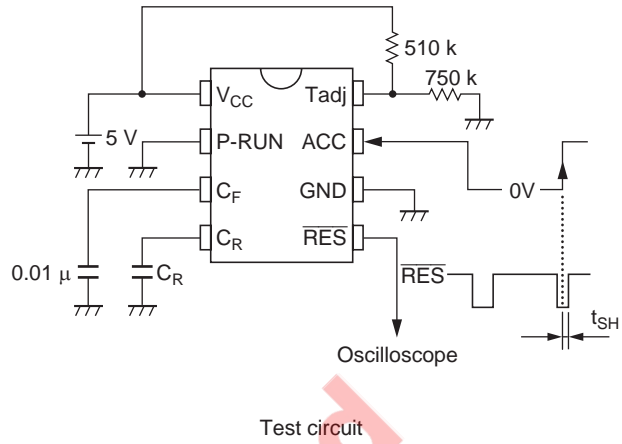
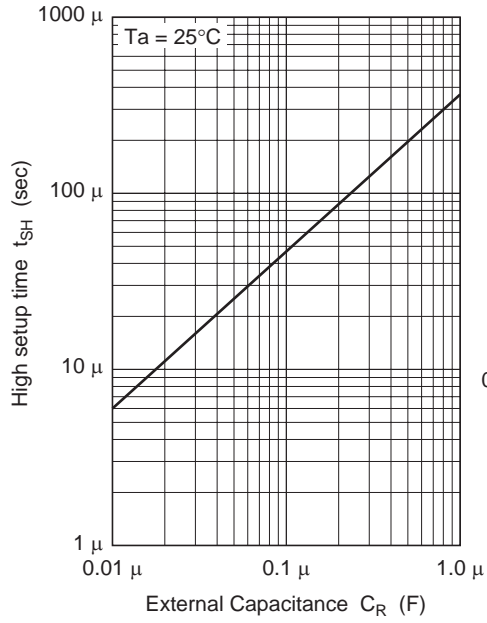

Low Setup Time vs. C_R Capacitance

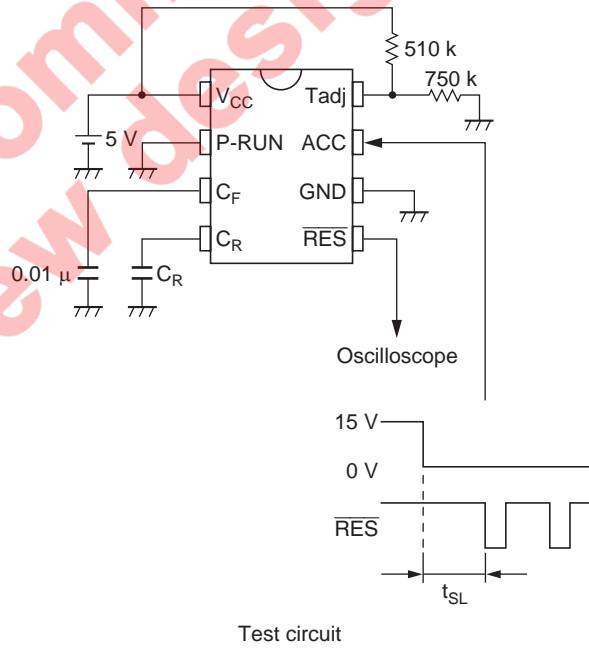
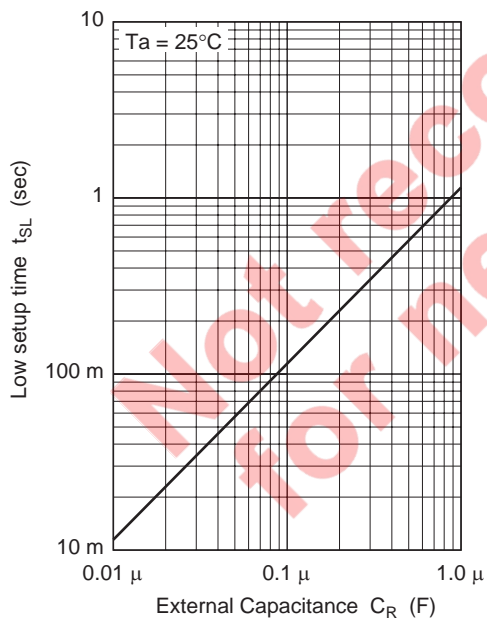

Reset High Time vs. K (Tadj Constant)

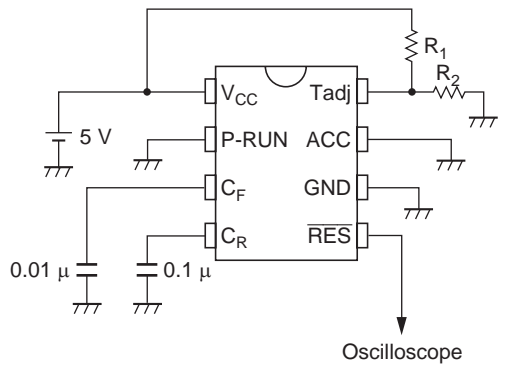
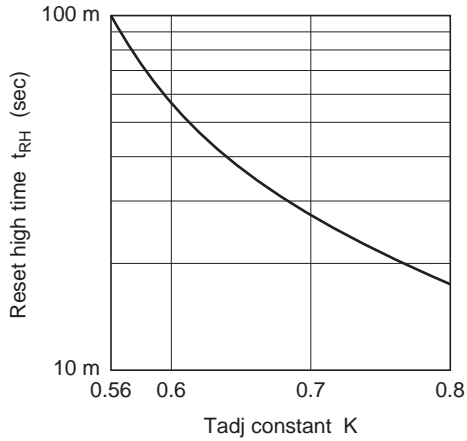

Test circuit

$$K = \frac{R_2}{R_1 + R_2}$$

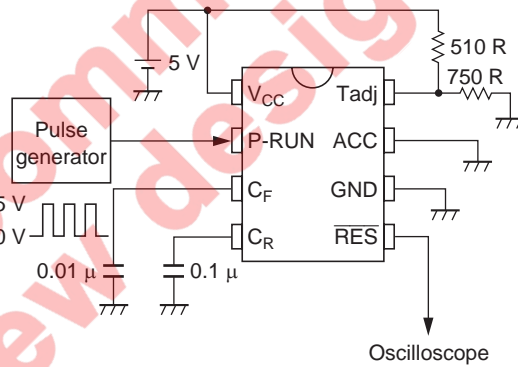
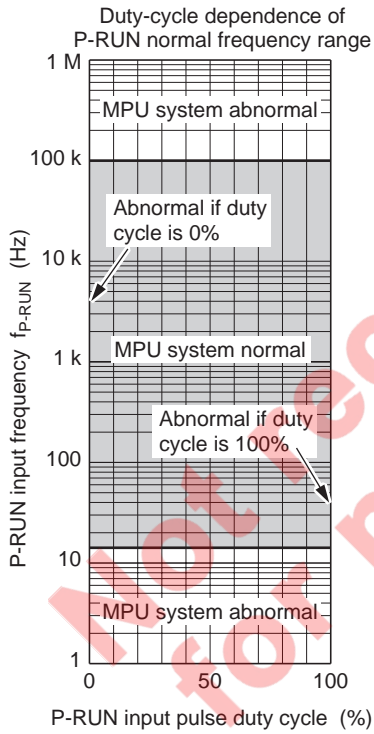

Test circuit

- Notes: 1. Normal detection is assumed when $\overline{\text{RES}}$ is not output.
 2. The figure at left is for a constant P-RUN frequency. See "8. Summary of cases where P-RUN frequency fluctuates" for cases where the frequency fluctuates.

P-RUN Input Frequency vs. K (Tadj constant)

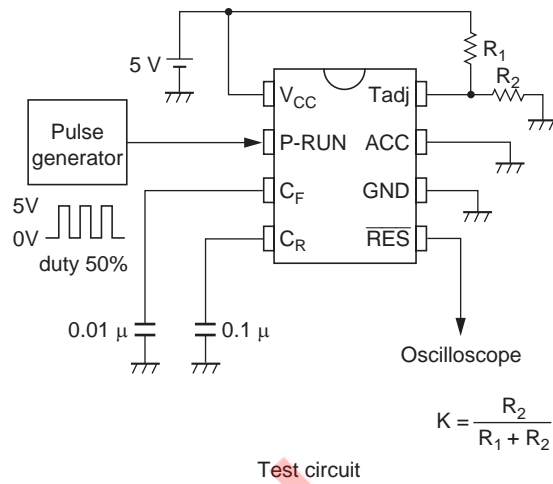
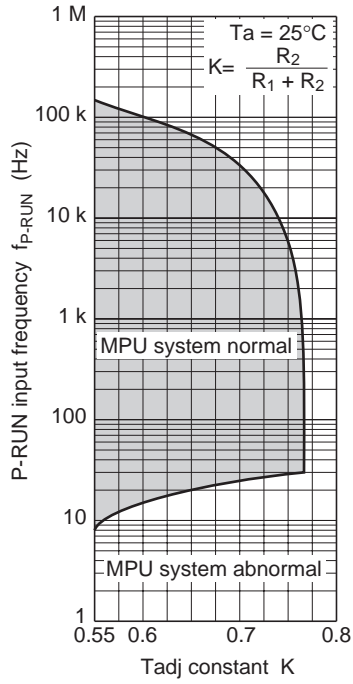

- Notes: 1. Normal detection is assumed when $\overline{\text{RES}}$ is not output.
 2. The figure at left is for a constant P-RUN frequency.

P-RUN High Threshold Frequency vs. C_F Capacitance

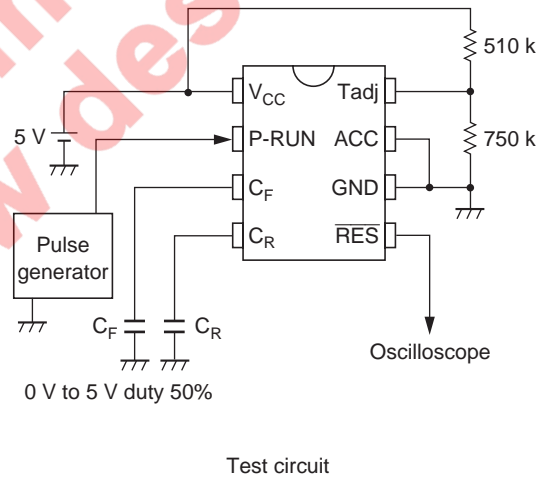
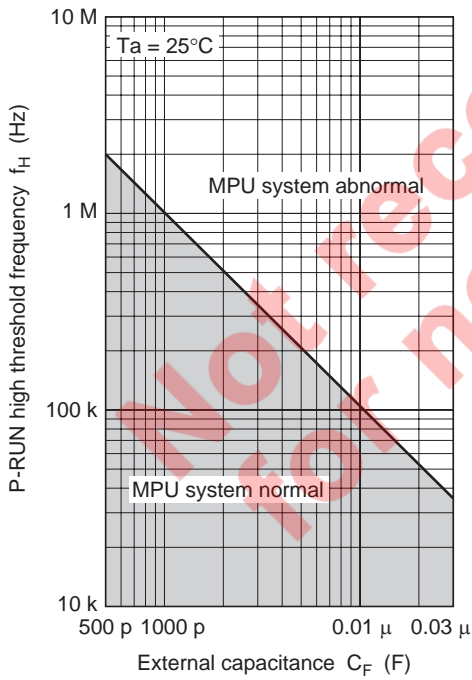

- Notes: 1. Normal detection is assumed when $\overline{\text{RES}}$ is not output.
 2. The figure at left is for a constant P-RUN frequency.

P-RUN Low Threshold Frequency vs. C_F Capacitance

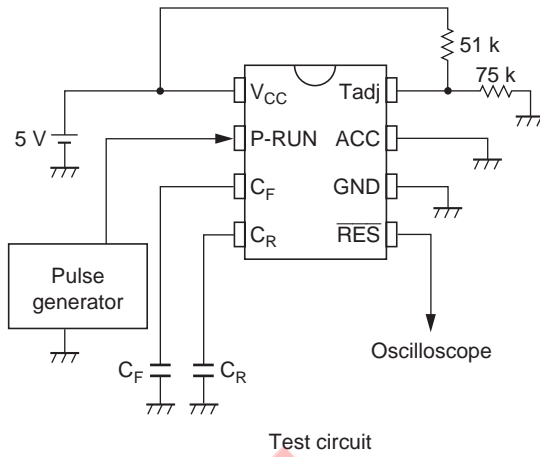
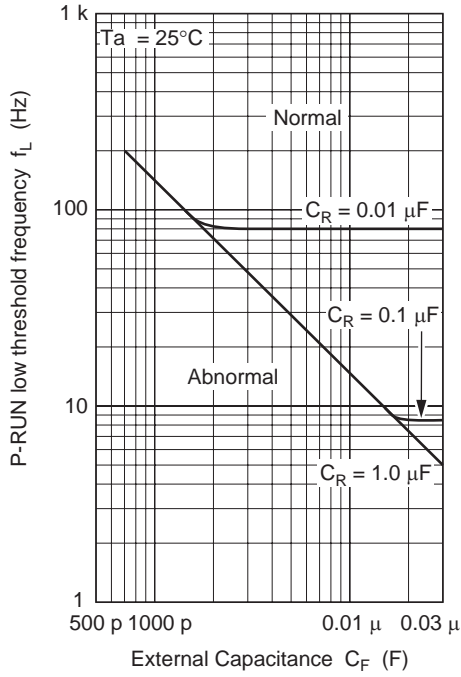

- Notes: 1. Normal detection is assumed when $\overline{\text{RES}}$ is not output.
- 2. The figure at left is for a constant P-RUN frequency.

P-RUN Input Frequency vs. Ambient Temperature

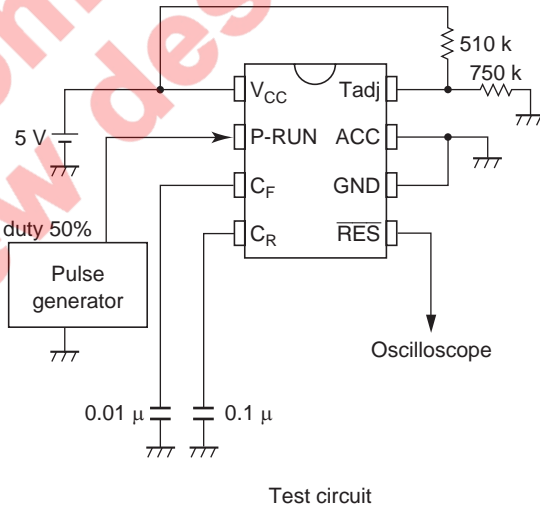
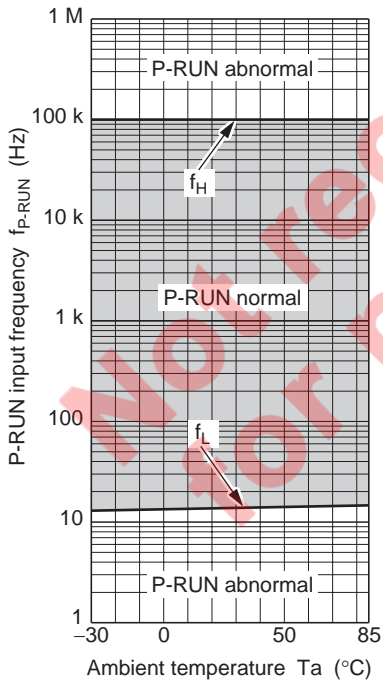

- Notes: 1. Normal detection is assumed when $\overline{\text{RES}}$ is not output.
- 2. The figure at left is for a constant P-RUN frequency.

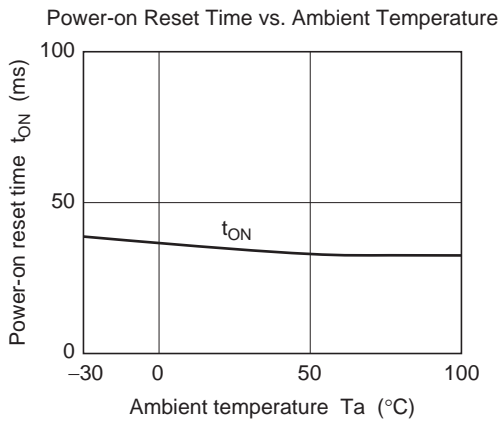

Power-on Reset Time vs. Ambient Temperature

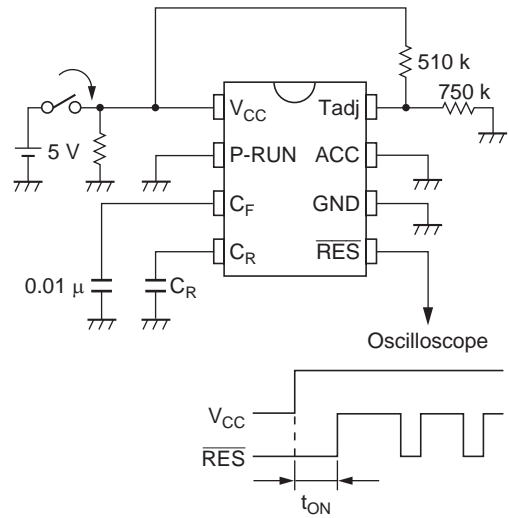
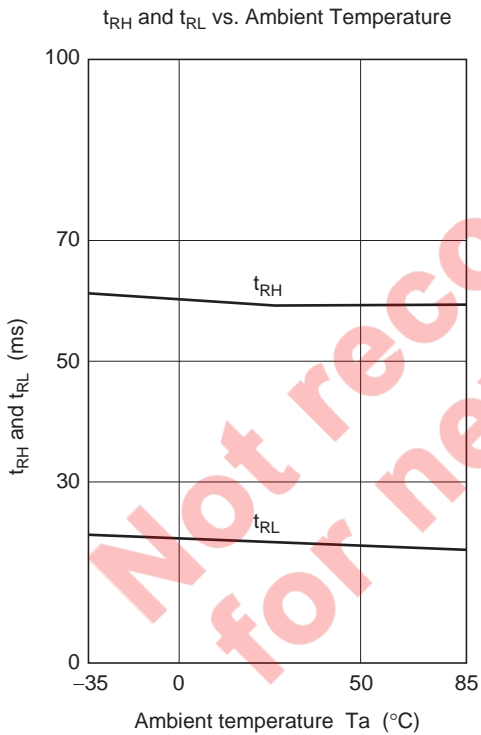

Test circuit

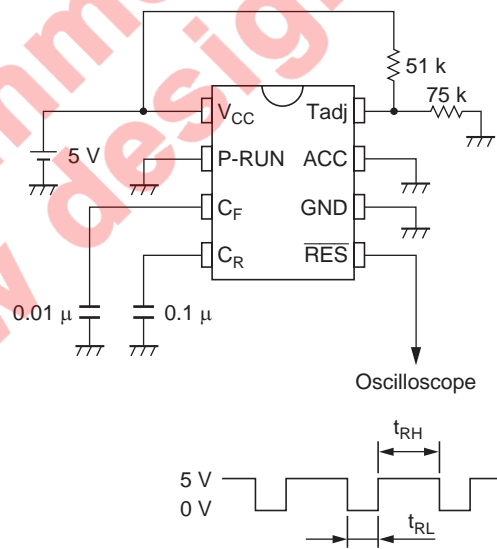

Test circuit

Package Dimensions

JEITA Package Code	RENESAS Code	Previous Code	MASS[Typ.]
P-SOP8-4.4x4.85-1.27	PRSP0008DE-A	FP-8D	0.1g

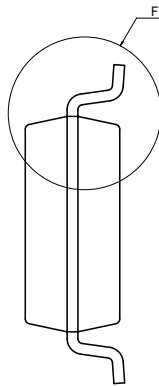
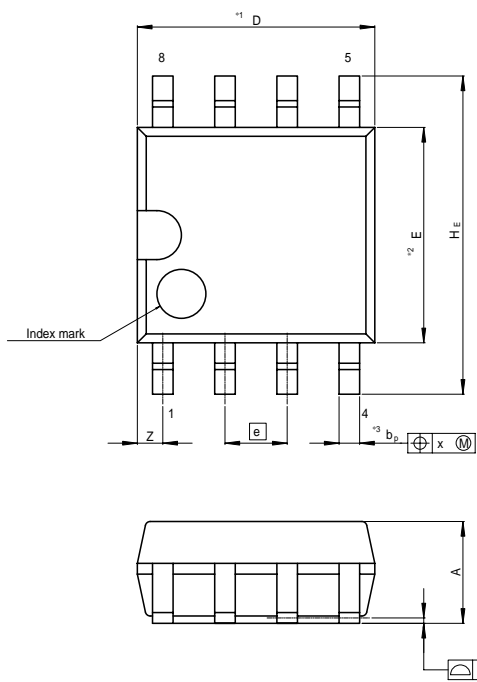

NOTE)
 1. DIMENSIONS*1 (Nom)*AND*2*
 DO NOT INCLUDE MOLD FLASH.
 2. DIMENSION*3*DOES NOT
 INCLUDE TRIM OFFSET.

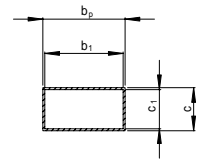

Terminal cross section

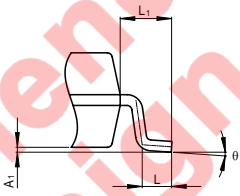

Detail F

Reference Symbol	Dimension in Millimeters		
	Min	Nom	Max
D	—	4.85	5.25
E	—	4.4	—
A ₂	—	—	—
A ₁	0.00	0.10	0.20
A	—	—	2.03
b _p	0.34	0.42	0.50
b ₁	—	0.40	—
c	0.17	0.22	0.27
c ₁	—	0.20	—
θ	0°	—	8°
H _E	6.35	6.50	6.75
e	—	1.27	—
x	—	—	0.12
y	—	—	0.15
Z	—	—	0.75
L	0.42	0.60	0.85
L ₁	—	1.05	—

Not recommended for new design

Renesas Technology Corp. Sales Strategic Planning Div. Nippon Bldg., 2-6-2, Ohte-machi, Chiyoda-ku, Tokyo 100-0004, Japan

Keep safety first in your circuit designs!

1. Renesas Technology Corp. puts the maximum effort into making semiconductor products better and more reliable, but there is always the possibility that trouble may occur with them. Trouble with semiconductors may lead to personal injury, fire or property damage.
Remember to give due consideration to safety when making your circuit designs, with appropriate measures such as (i) placement of substitutive, auxiliary circuits, (ii) use of nonflammable material or (iii) prevention against any malfunction or mishap.

Notes regarding these materials

1. These materials are intended as a reference to assist our customers in the selection of the Renesas Technology Corp. product best suited to the customer's application; they do not convey any license under any intellectual property rights, or any other rights, belonging to Renesas Technology Corp. or a third party.
 2. Renesas Technology Corp. assumes no responsibility for any damage, or infringement of any third-party's rights, originating in the use of any product data, diagrams, charts, programs, algorithms, or circuit application examples contained in these materials.
 3. All information contained in these materials, including product data, diagrams, charts, programs and algorithms represents information on products at the time of publication of these materials, and are subject to change by Renesas Technology Corp. without notice due to product improvements or other reasons. It is therefore recommended that customers contact Renesas Technology Corp. or an authorized Renesas Technology Corp. product distributor for the latest product information before purchasing a product listed herein.
The information described here may contain technical inaccuracies or typographical errors.
Renesas Technology Corp. assumes no responsibility for any damage, liability, or other loss rising from these inaccuracies or errors.
Please also pay attention to information published by Renesas Technology Corp. by various means, including the Renesas Technology Corp. Semiconductor home page (<http://www.renesas.com>).
 4. When using any or all of the information contained in these materials, including product data, diagrams, charts, programs, and algorithms, please be sure to evaluate all information as a total system before making a final decision on the applicability of the information and products. Renesas Technology Corp. assumes no responsibility for any damage, liability or other loss resulting from the information contained herein.
 5. Renesas Technology Corp. semiconductors are not designed or manufactured for use in a device or system that is used under circumstances in which human life is potentially at stake. Please contact Renesas Technology Corp. or an authorized Renesas Technology Corp. product distributor when considering the use of a product contained herein for any specific purposes, such as apparatus or systems for transportation, vehicular, medical, aerospace, nuclear, or undersea repeater use.
 6. The prior written approval of Renesas Technology Corp. is necessary to reprint or reproduce in whole or in part these materials.
 7. If these products or technologies are subject to the Japanese export control restrictions, they must be exported under a license from the Japanese government and cannot be imported into a country other than the approved destination.
Any diversion or reexport contrary to the export control laws and regulations of Japan and/or the country of destination is prohibited.
 8. Please contact Renesas Technology Corp. for further details on these materials or the products contained therein.
-

RENESAS SALES OFFICES



<http://www.renesas.com>

Refer to "<http://www.renesas.com/en/network>" for the latest and detailed information.

Renesas Technology America, Inc.
450 Holger Way, San Jose, CA 95134-1368, U.S.A
Tel: <1> (408) 382-7500, Fax: <1> (408) 382-7501

Renesas Technology Europe Limited
Dukes Meadow, Millboard Road, Bourne End, Buckinghamshire, SL8 5FH, U.K.
Tel: <44> (1628) 585-100, Fax: <44> (1628) 585-900

Renesas Technology Hong Kong Ltd.
7th Floor, North Tower, World Finance Centre, Harbour City, 1 Canton Road, Tsimshatsui, Kowloon, Hong Kong
Tel: <852> 2265-6688, Fax: <852> 2730-6071

Renesas Technology Taiwan Co., Ltd.
10th Floor, No.99, Fushing North Road, Taipei, Taiwan
Tel: <886> (2) 2715-2888, Fax: <886> (2) 2713-2999

Renesas Technology (Shanghai) Co., Ltd.
Unit2607 Ruijing Building, No.205 Maoming Road (S), Shanghai 200020, China
Tel: <86> (21) 6472-1001, Fax: <86> (21) 6415-2952

Renesas Technology Singapore Pte. Ltd.
1 Harbour Front Avenue, #06-10, Keppel Bay Tower, Singapore 098632
Tel: <65> 6213-0200, Fax: <65> 6278-8001