



# 500mA Dual Channel Movie/Flash LED Driver

## FEATURES

- Dual Mode (Movie or Flash) operation
- Independent Movie/Flash LED current control
- Can drive 2, 3, 4 or 6 LEDs
- High LED Current (250mA max per channel)
- Power efficiency up to 85%
- Dual frequency mode 1.2MHz and 900kHz
- Soft-start inrush current
- Adjustable overvoltage protection
- Thermal shutdown protection
- Operating temperature range -40°C to +85°C
- 12-pad TDFN 3mm x 3mm package

## APPLICATIONS

- Camera flash
- Flash light
- High-power white LEDs
- Digital still cameras
- Color LCD backlighting

## ORDERING INFORMATION

Part Number	Package	Quantity per Reel	Package Marking
CAT4134HV2-T2	TDFN-12 <sup>(1)</sup>	2,000	HAAS
CAT4134HV2-GT2	TDFN-12 <sup>(2)</sup>	2,000	HAAU

Notes: (1) Matte-Tin Plated Finish (RoHS-compliant).  
(2) NiPdAu Plated Finish (RoHS-compliant).

## DESCRIPTION

The CAT4134 is a high power, dual channel boost converter which provides two matched LED currents. Output current levels are controlled by one of two resistors RSET or RFLASH. When the FLASH input pin is low (movie mode), RSET sets the current. When FLASH is high (flash mode), the resistor RFLASH sets the LED current. Each channel drives two or three white LEDs in series and provides a regulated current to control their brightness. Input supply down to 3V is supported, making the device ideal for Li-Ion battery applications.

High frequency low noise operation allows the device to be used with small external inductors and ceramic capacitors while still maintaining excellent efficiency. When not in use the device can be placed into a “zero” quiescent mode via the shutdown pin.

In addition to soft-start control and current limiting, the CAT4134 include thermal shutdown protection. A dedicated overvoltage pin (OVP) allows the user to limit the maximum LED supply voltage. The device is packaged in the 12-pad TDFN 3mm x 3mm.

For Ordering Information details, see page 12.

## PIN CONFIGURATION

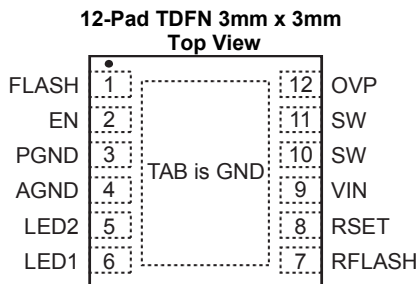

## TYPICAL APPLICATION CIRCUIT

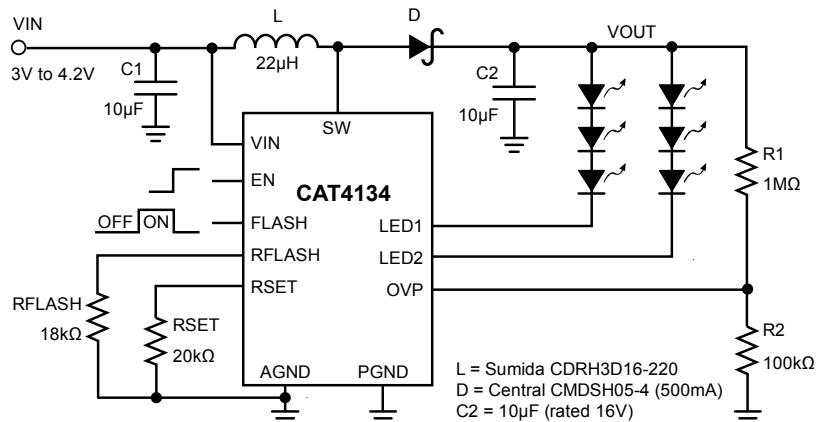

**ABSOLUTE MAXIMUM RATINGS**

Parameters	Ratings	Units
SW voltage	20	V
VIN voltage	8	V
EN, FLASH, RSET, RFLASH voltage	VIN + 0.6V	V
LED1, LED2 voltage	8	V
Output Current per Channel	300	mA
Storage Temperature Range	-65 to +160	°C
Junction Temperature Range	-40 to +125	°C
Lead Temperature	300	°C
ESD Rating – Human Body Model (HBM)	2000	V

**RECOMMENDED OPERATING CONDITIONS**

Parameter	Range	Units
VIN	2.8 to 4.2	V
Ambient Temperature Range	-40 to +85	°C
Flash mode current per channel	25 to 250	mA
Movie mode current per channel	5 to 50	mA

**ELECTRICAL OPERATING CHARACTERISTICS**

Over recommended operating conditions unless specified otherwise.

$V_{IN} = 3.6V$ ,  $EN = V_{IN}$  and at ambient temperature of 25°C.

Symbol	Parameter	Conditions	Min	Typ	Max	Unit
$I_Q$	Quiescent Current (not switching)	$V_{LED1} > 0.5V$ , $V_{LED2} > 0.5V$		100	250	$\mu A$
$I_{SD}$	Shutdown Current	$EN = 0V$		1		$\mu A$
$I_{SW}$	Switch Current Limit	Movie Mode (FLASH = Low) Flash Mode (FLASH = High)	0.5 1.7	1 2		A
$R_{SW}$	Switch Resistance	$I_{SW} = 1000mA$		0.3	0.5	$\Omega$
$I_{LK}$	Switch Leakage Current	Switch Off, $V_{SW} = 5V$			5	$\mu A$
$F_{OSC}$	Oscillator Frequency	Movie Mode Flash Mode		1.2 0.9		MHz
$V_{OVP}$	OVP pin threshold		1.10	1.20	1.30	V
$\eta$	Efficiency	$V_{OUT} = 10V$ , Load = 200mA		85		%
$T_{SD}$	Thermal Shutdown			150		°C
$T_{HYST}$	Thermal Hysteresis			20		°C
$V_{UVLO}$	Undervoltage Lock Out (UVLO) Threshold	Disabled when $V_{IN} < V_{UVLO}$		1.9	2.2	V

**EN LOGIC CONTROL INPUT**

$V_{SDHI}$	Logic High Threshold	$EN > V_{SDHI}$ Enables Device	0.4	0.7	1.5	V
$V_{SDLO}$	Logic Low Threshold			0.7		
$I_{SDBIAS}$	Input Bias current	$EN = 3V$		10	40	$\mu A$

**ELECTRICAL OPERATING CHARACTERISTICS (continued)**

Over recommended operating conditions unless specified otherwise.

 $V_{IN} = 3.6V$ ,  $EN = V_{IN}$  and at ambient temperature of  $25^{\circ}C$ .

Symbol	Parameter	Conditions	Min	Typ	Max	Unit
$V_{RSET}$	RSET pin voltage	$22k\Omega < R_{SET} < 200k\Omega$	1.10	1.20	1.30	V
$V_{RFLASH}$	RFLASH pin voltage	$22k\Omega < R_{FLASH} < 200k\Omega$	1.10	1.20	1.30	V
$V_{LED}$	LED1, LED2 Pin Voltage (whichever is the lower)	Both Flash and Movie Mode (lower voltage pin is regulated)		400		mV
$I_{LED}$	Programmed LED Current	$R_{SET} = 21.6k\Omega$ $R_{FLASH} = 43.2k\Omega$ $R_{FLASH} = 21.6k\Omega$		20 50 100		mA
$I_{LED-RAN}$	LED Current Adjust Range per LED output	In Movie mode In Flash mode	5 25		50 200	mA
$I_{LED-ACC}$	LED Current Accuracy			$\pm 5$		%
$I_{LED-DEV}$	LED Current Matching			$\pm 5$		%

**FLASH CONTROL LOGIC INPUT**

$V_{FHI}$	Logic High Threshold	$FLASH > V_{FHI}$ Flash Enabled	0.4	0.7	1.5	V
$V_{FLO}$	Logic Low Threshold			0.7		
$I_{INPUT}$	Input Bias current	$FLASH = 3V$		10	40	$\mu A$

### TYPICAL CHARACTERISTICS

V<sub>IN</sub> = 3.6V, FLASH = V<sub>IN</sub>, C<sub>IN</sub> = 4.7μF, C<sub>OUT</sub> = 10μF, L = 22μH with 2 LEDs at 100mA, T<sub>AMB</sub> = 25°C, unless otherwise specified.

**LED Current Regulation (100mA load)**

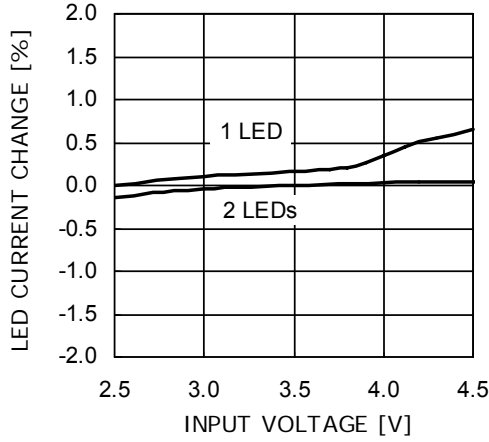

**LED Current Regulation (200mA load, Flash)**

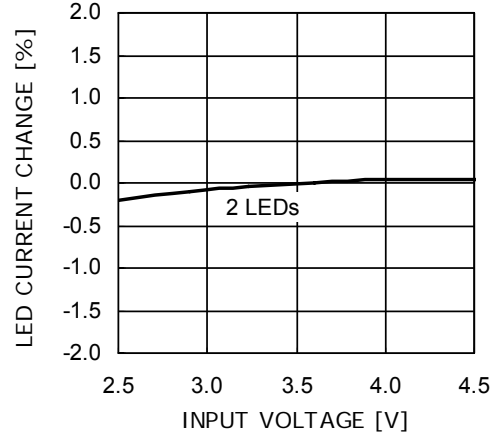

**Current Gain vs. RFLASH**

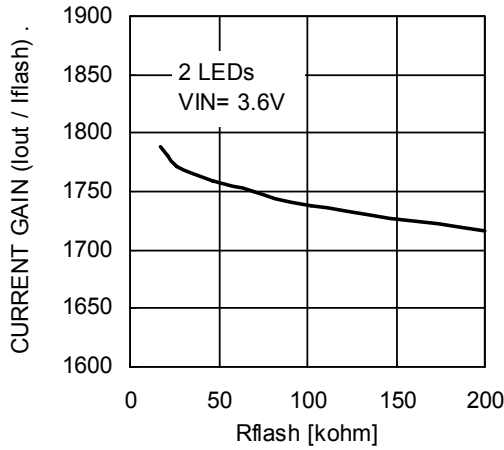

**LED Current Regulation (100mA load, Flash)**

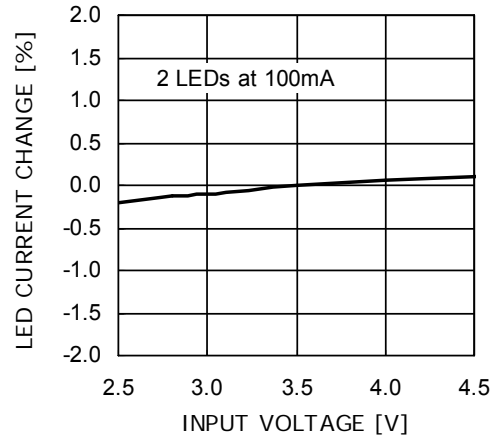

**Efficiency vs. Output Current (Flash mode)**

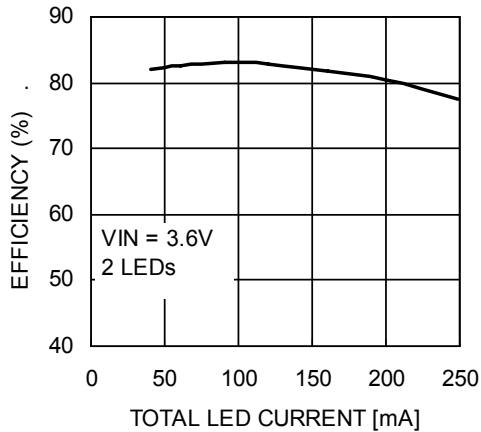

**Efficiency vs. Input Voltage (Flash mode)**

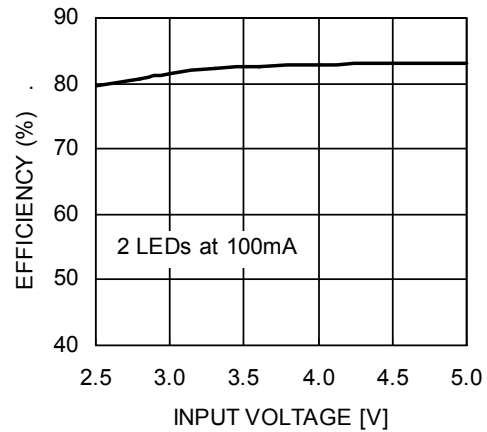

**TYPICAL CHARACTERISTICS**

VIN = 3.6V, FLASH = VIN, CIN = 4.7µF, COUT = 10µF, L = 22µH with 2 LEDs at 100mA, TAMB = 25°C, unless otherwise specified.

**Power-up Transient (2 LEDs at 200mA)**

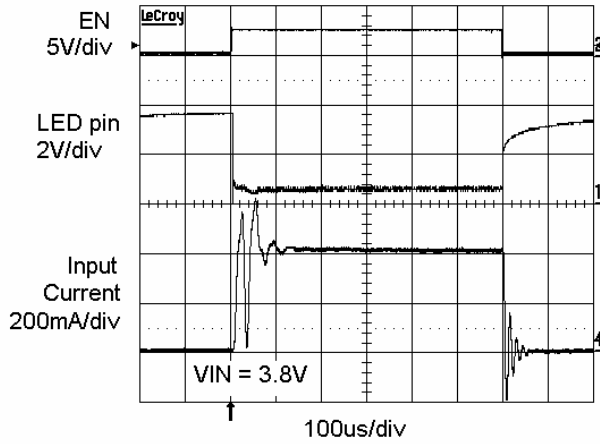

**Power-up Transient (2 LEDs at 200mA)**

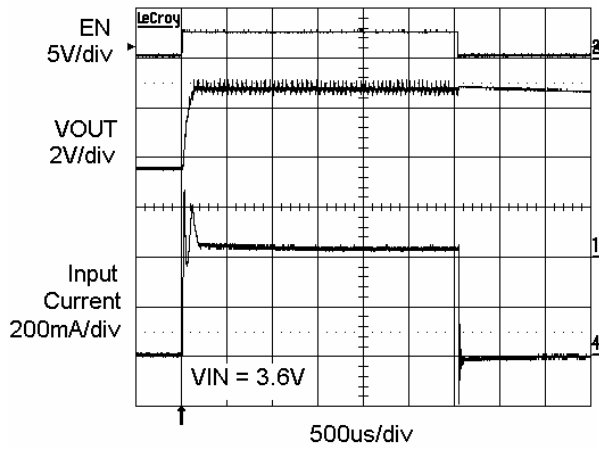

**Power-up Transient (2 LEDs at 200mA)**

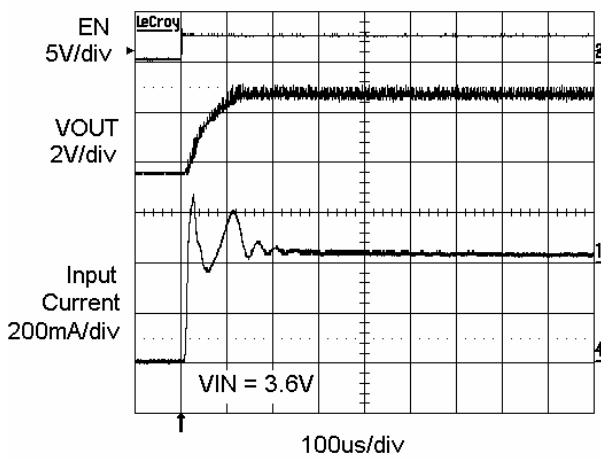

**Power-up Transient (2 LEDs at 200mA)**

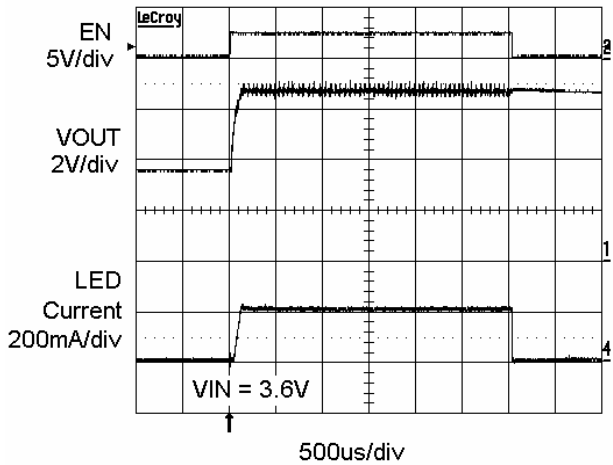

**Switching Waveform in Flash mode (2 LEDs)**

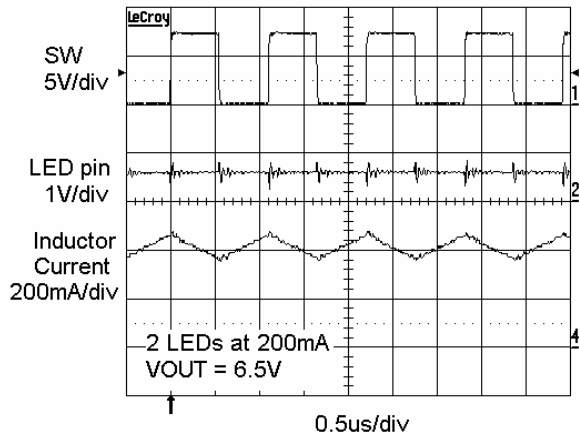

### TYPICAL CHARACTERISTICS

V<sub>IN</sub> = 3.6V, C<sub>IN</sub> = 4.7μF, C<sub>OUT</sub> = 10μF, L = 22μH with 2 LEDs at 100mA, T<sub>AMB</sub> = 25°C, unless otherwise specified.

**Switching Frequency vs. Supply Voltage**

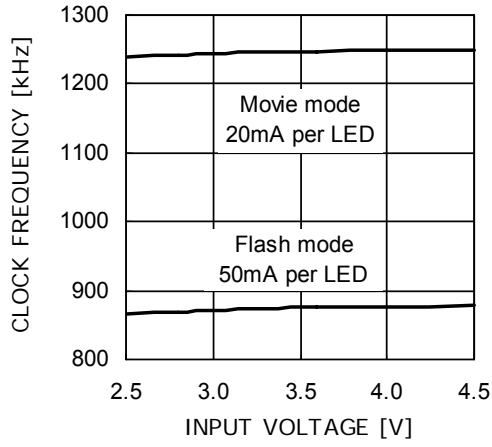

**Enable Flash waveform**

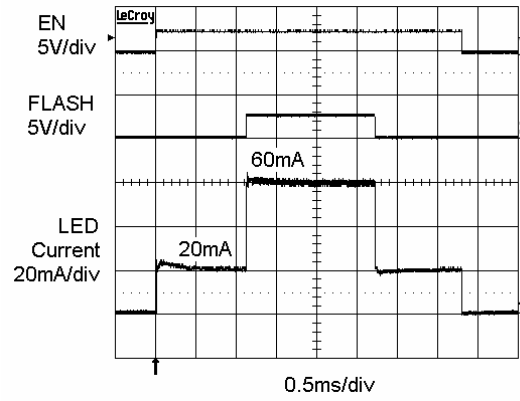

## PIN DESCRIPTION

Pin #	Name	Function
1	FLASH	Logic input, set high to select the flash mode.
2	EN	Enable control logic input (Active High).
3	PGND	Power ground reference.
4	AGND	Analog ground reference.
5	LED2	LED channel 2, connected to the LED cathode.*
6	LED1	LED channel 1, connected to the LED cathode.*
7	RFLASH	Resistor connection to set Flash mode LED current.
8	RSET	Resistor connection to set Movie mode LED current.
9	VIN	Power supply input.
10,11	SW	Drain connection of low resistance power MOSFET.
12	OVP	Over Voltage Protection comparator input

\* LED1 or LED2 pin should not be left floating.

## PIN FUNCTION

**VIN** is the supply voltage input. The device is compatible with supply voltages down to 2.8V and up to 4.2V. Internal under-voltage lockout (UVLO) circuitry will automatically prevent the device from operating whenever the supply falls below 1.9V. For operation up to maximum rated loads a bypass ceramic capacitor of 10µF is recommended between the VIN and GND pins near the device.

**EN** is the enable logic input (active high). When the pin voltage is taken below 0.4V, the device enters shutdown mode, drawing nearly zero current. At pin voltages greater than 1.4V, the device is fully enabled.

**FLASH** is the logic input (active high) used to control Flash mode operation. When the pin voltage is taken above 1.4V, the device transitions from Movie mode to Flash mode. When the pin voltage is taken back below 0.4V, the device returns back to Movie mode operation.

**RSET, RFLASH** pins allow to set the LED current respectively in Movie and Flash mode. These pins, regulated at 1.2V, must be connected to a pull-down resistor tied to ground. The LED current is a function of the resistor value.

**GND** is the ground reference for the driver. The pin must be connected to the ground plane on the PCB.

**SW** pin is the drain terminal of the internal low resistance power switch. The inductor and the Schottky diode anode should be connected to the SW pin. Traces going to the SW pin should be as short as possible with minimum loop area. This pin contains over-voltage circuitry which becomes active above 18V. In the event of an “open-LED” fault condition, the device will enter a low power mode and the SW pin will be clamped to approximately 21V.

**LED1, LED2** provide the internal regulated current for each of the LED cathodes. These pins enter a high impedance zero current state whenever the device is placed in shutdown mode. In applications with only one string of LEDs, the two LED pins should be tied together. LED pins should not be left floating.

**OVP** is the overvoltage protection input pin. When the pin voltage exceeds the 1.2V overvoltage threshold ( $V_{OVP}$ ), the driver stops switching. The output VOUT then drops down. As soon as the OVP pin voltage falls under the  $V_{OVP}$  threshold, the part starts switching again.

**TAB** is the exposed pad underneath the package. For best thermal performance, the tab should be soldered to the PCB and connected to the ground plane.

## DEVICE OPERATION

The device is powered from the input pin VIN. A switching frequency of 1.2MHz is used in Movie mode, when the FLASH input is low. Continuous LED current up to 50mA is controlled by the RSET resistor. For higher load current, the Flash mode is selected by setting the FLASH input pin high. RFLASH now controls the LED current. In flash mode, the driver efficiency is kept high even under high load current by using a lower switching frequency of 900kHz. In movie mode, the higher frequency of 1.2MHz provides a lower noise operation.

### Overvoltage Protection (OVP)

To prevent the SW pin voltage from exceeding the internal switch maximum voltage rating, an overvoltage protection (OVP) function is supported. The OVP pin allows to set the maximum operating voltage on the output VOUT using external resistors R1 and R2. The

resistor ratio sets the maximum output voltage as shown in the equation below:

$$R1/R2 = (VOUT_{MAX} / 1.2) - 1.2$$

$VOUT_{MAX}$  should always be higher than the total LED forward voltage ( $\Sigma Vf$ ) plus 1.2V. Also  $VOUT$  must be less than  $\Sigma Vf + 8V$ .

$$\Sigma Vf + 1.2V < VOUT_{MAX} < \Sigma Vf + 8V < 16V$$

If the overvoltage protection is not needed, then the OVP pin should be connected to Ground. In that case, the maximum voltage on the SW pin is set to 17V.

## BLOCK DIAGRAM

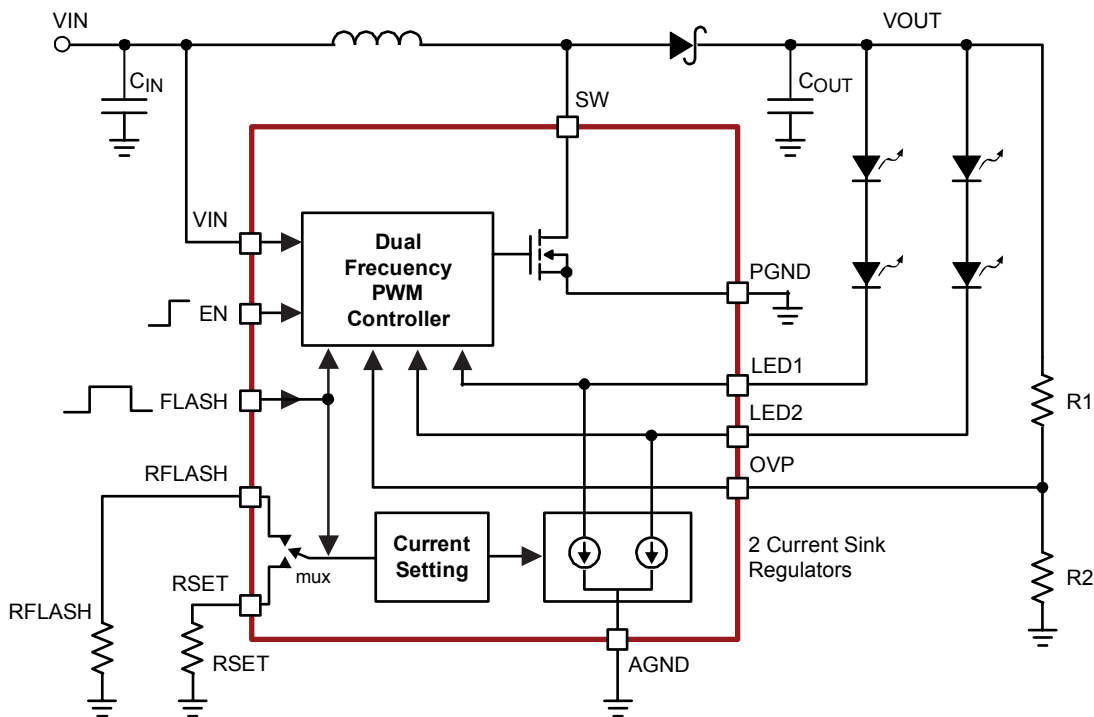



## APPLICATION INFORMATION

The typical application for the CAT4134 is in a camera-equipped cellular phone where the LEDs are used for illumination in flash mode with short duration high-current pulse and in movie mode with continuous lighter load. In movie mode, the FLASH pin is set low.

**Note:**

Hot-plugging the LEDs while the output is fully charged is not recommended. If the LEDs are disconnected, the device should first be powered-down and the output discharged before reconnecting the LEDs to the output and the LED pins.

## TIMING DIAGRAM

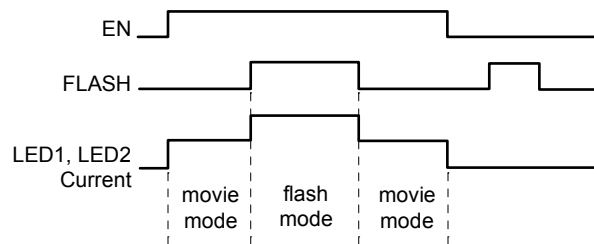

## LED CURRENT SETTING

### Flash Mode

The enable EN and FLASH logic input signals control the LED current. When both the EN and FLASH inputs are high, the driver is in flash or strobe mode. In this mode, the LED1 and LED2 pin currents are set by the resistor RFLASH and are regulated to 1800 times the current in the RFLASH resistor and follows the equation:

$$\text{LED current} = 1800 \times 1.2\text{V} / \text{RFLASH}$$

### Movie Mode

When the EN input is high and FLASH is low, the driver is in movie mode. In this mode, the LED1 and LED2 pin currents are set by the resistor RSET and are regulated to 360 times the current in the RSET resistor and follows the equation:

$$\text{LED current} = 360 \times 1.2\text{V} / \text{RSET}$$

Table 1 lists the various LED currents and the associated resistor values in movie and flash modes.

**Table 1. Resistor Selection in Movie and Flash Mode**

Movie Mode		Flash Mode	
LED Current (mA)	RSET (kΩ)	LED Current (mA)	RFLASH (kΩ)
5	86.4	50	43.2
10	43.2	75	28.8
20	21.6	100	21.6
30	14.4	150	14.4

### Shutdown Mode

When the EN input is low, the driver is in shutdown mode and there is no current flowing in either LED1 or LED2 pins.

## TYPICAL APPLICATIONS

The CAT4134 can drive one or two strings of 2 to 3 LEDs in series resulting in combinations of 2, 3, 4, 6 LEDs.

The resistor ratio  $R1/R2$  sets the maximum  $V_{OUT}$  during an open-LED fault condition and provides the overvoltage protection.

For applications with 2 LEDs in series and  $V_{OUT\_MAX}$  at 10V, the ratio  $R1/R2$  is 7.

For applications with 3 LEDs in series and  $V_{OUT\_MAX}$  at 13.5V, the ratio  $R1/R2$  is 10.

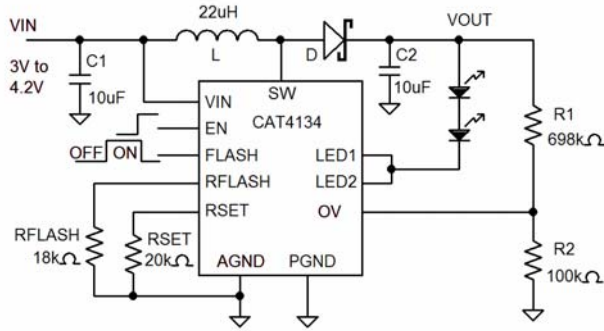

**2 LED Application**

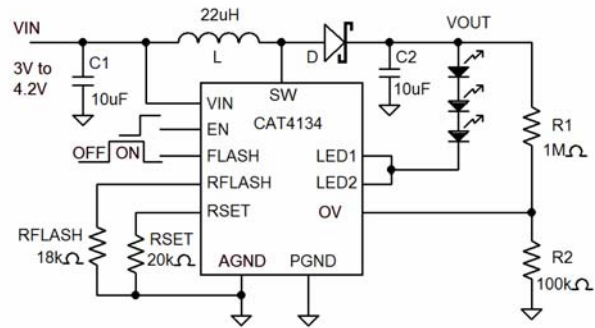

**3 LED Application**

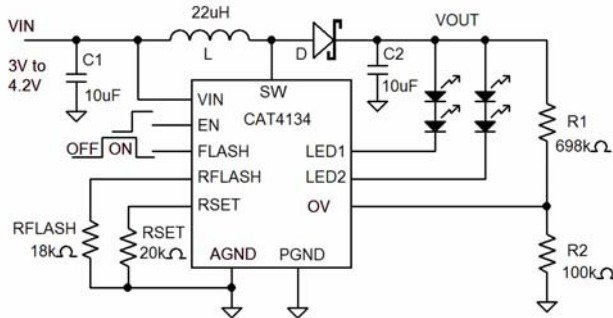

**4 LED Application**

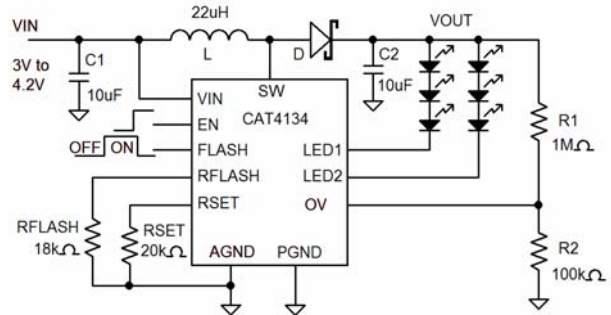

**6 LED Application**

**PACKAGE OUTLINE DRAWINGS**

TDFN 12-Pad 3mm x 3mm, (HV2) <sup>(1) (2)</sup>

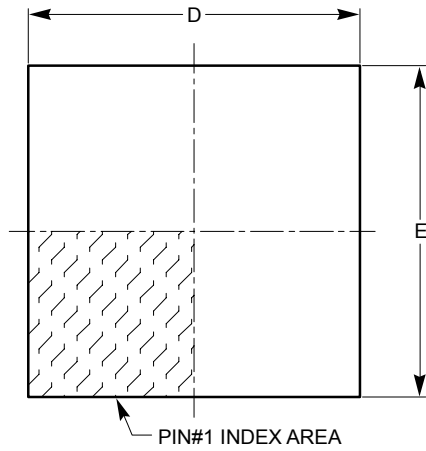

TOP VIEW

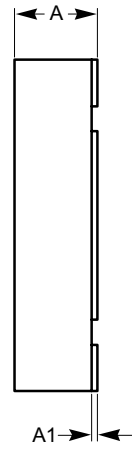

SIDE VIEW

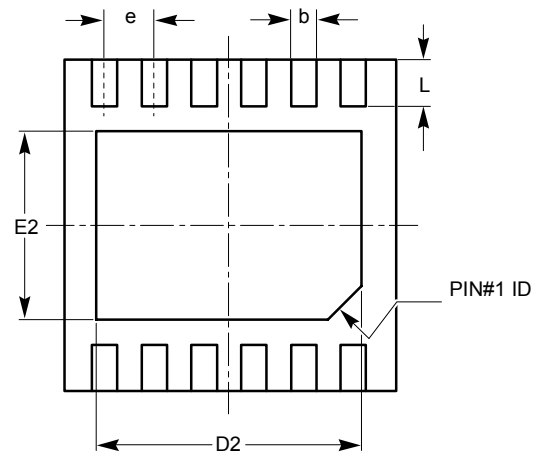

BOTTOM VIEW

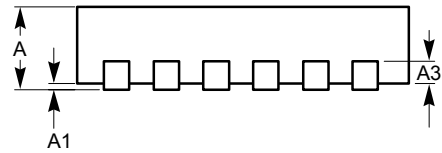

FRONT VIEW

SYMBOL	MIN	NOM	MAX
A	0.70	0.75	0.80
A1	0.00	0.02	0.05
A3	0.178	0.203	0.228
b	0.18	0.23	0.30
D	2.90	3.00	3.10
D2	2.30	2.40	2.50
E	2.90	3.00	3.10
E2	1.55	1.70	1.75
e	0.45 BSC		
L	0.30	0.40	0.50
M	0.25	0.30	0.35
N	0.60	0.70	0.80
P	2.70	3.00	3.10
R	2.25 TYP		

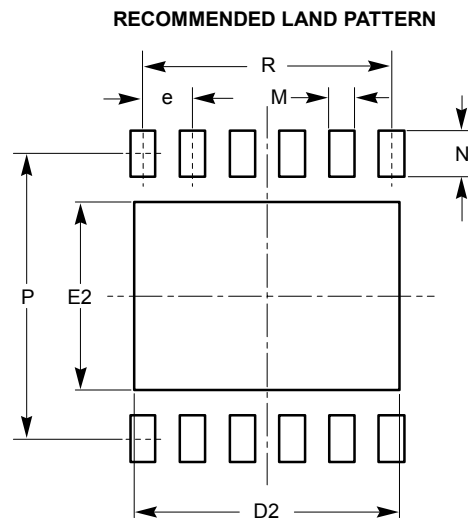

For current Tape and Reel information, download the PDF file from:  
<http://www.catsemi.com/documents/tapeandreel.pdf>.

**Notes:**

- (1) All dimensions are in millimeters.
- (2) Complies with JEDEC standard MO-229

**EXAMPLE OF ORDERING INFORMATION**

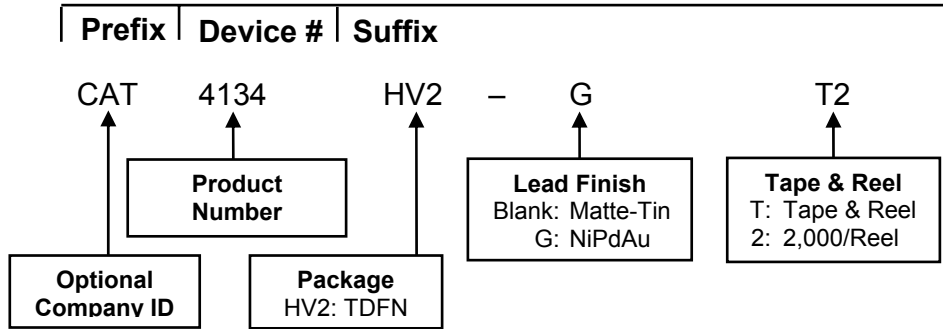

**For Product Top Mark Codes, click here:**  
<http://www.catsemi.com/techsupport/producttopmark.asp>

**Notes:**

- (1) All packages are RoHS-compliant (Lead-free, Halogen-free).
- (2) The standard lead finish is NiPdAu.
- (3) The device used in the above example is a CAT4134HV2-GT2 (TDFN, NiPdAu, Tape and Reel, 2,000/Reel).
- (4) For additional package and temperature options, please contact your nearest Catalyst Semiconductor Sales office.

## REVISION HISTORY

Date	Rev.	Reason
18-Oct-06	A	Initial Issue
13-May-08	B	Add TDFN in NiPdAu plated finish. Update Package Outline Drawing. Update Example of Ordering Information. Add MD- to the document number.

---

### *Copyrights, Trademarks and Patents*

© Catalyst Semiconductor, Inc.

Trademarks and registered trademarks of Catalyst Semiconductor include each of the following:

Adaptive Analog™, Beyond Memory™, DPP™, EZDim™, LDD™, MiniPot™, Quad-Mode™ and Quantum Charge Programmable™

Catalyst Semiconductor has been issued U.S. and foreign patents and has patent applications pending that protect its products.

*CATALYST SEMICONDUCTOR MAKES NO WARRANTY, REPRESENTATION OR GUARANTEE, EXPRESS OR IMPLIED, REGARDING THE SUITABILITY OF ITS PRODUCTS FOR ANY PARTICULAR PURPOSE, NOR THAT THE USE OF ITS PRODUCTS WILL NOT INFRINGE ITS INTELLECTUAL PROPERTY RIGHTS OR THE RIGHTS OF THIRD PARTIES WITH RESPECT TO ANY PARTICULAR USE OR APPLICATION AND SPECIFICALLY DISCLAIMS ANY AND ALL LIABILITY ARISING OUT OF ANY SUCH USE OR APPLICATION, INCLUDING BUT NOT LIMITED TO, CONSEQUENTIAL OR INCIDENTAL DAMAGES.*

Catalyst Semiconductor products are not designed, intended, or authorized for use as components in systems intended for surgical implant into the body, or other applications intended to support or sustain life, or for any other application in which the failure of the Catalyst Semiconductor product could create a situation where personal injury or death may occur.

Catalyst Semiconductor reserves the right to make changes to or discontinue any product or service described herein without notice. Products with data sheets labeled "Advance Information" or "Preliminary" and other products described herein may not be in production or offered for sale.

Catalyst Semiconductor advises customers to obtain the current version of the relevant product information before placing orders. Circuit diagrams illustrate typical semiconductor applications and may not be complete.

---



Catalyst Semiconductor, Inc.

Corporate Headquarters

2975 Stender Way

Santa Clara, CA 95054

Phone: 408.542.1000

Fax: 408.542.1200

www.catsemi.com

Document No: MD-5021

Revision: B

Issue date: 05/13/08