

*Preliminary*

# 5-30GHz ATTENUATOR

## GaAs Monolithic Microwave IC

### Description

The CHT4690 is a variable 5-30GHz attenuator designed for a wide range of applications, from military to commercial communication systems. The backside of the chip is both RF and DC grounds. This helps simplify the assembly process. The circuit is manufactured with a MESFET process, 0.7µm gate length, via holes through the substrate and air bridges.

It is supplied in chip form.

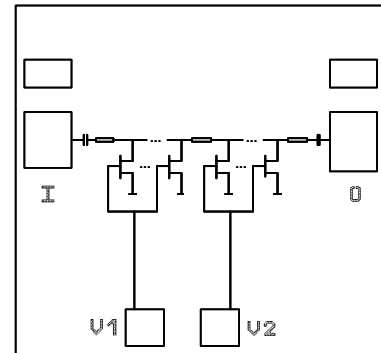

### Main Features

- | Broadband performance : 5-30GHz
- | 25dBm typical input 1dB compression point (any attenuation)
- | 30dB dynamic range
- | DC bias : -5V<V1<0V ; -5V<V2<0V

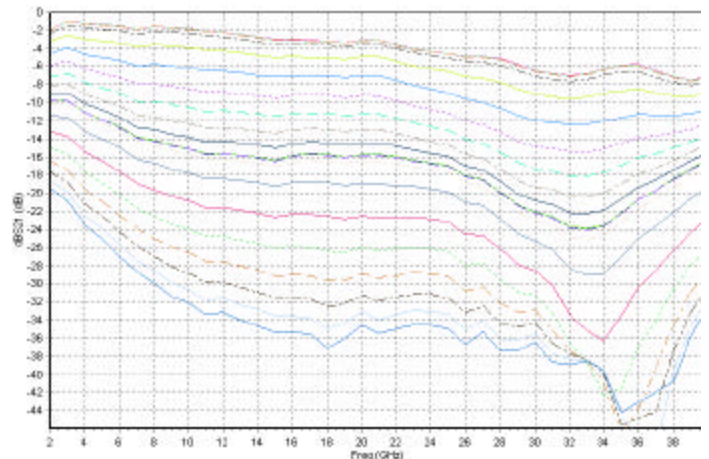

### Main Characteristics

Tamb. = 25°C

Symbol	Parameter	Min	Typ	Max	Unit
Fin	Input frequency range	5		30	GHz
Min Att.	S21  (V1=-5V;V2=-5V) (5 to 20GHz)		-3		dB
Max Att.	S21  (V1=0V;V2=0V) (10 to 30GHz)		-30		dB
Pin1dB	Input 1dB compression point (any attenuation)		25		dBm

ESD Protection : Electrostatic discharge sensitive device. Observe handling precautions !

*Preliminary*

## Electrical Characteristics

Tamb. = 25°C

Symbol	Parameter	Min	Typ	Max	Unit
Fin	Input frequency range	5		30	GHz
Min Att.	S21  (V1=-5V;V2=-5V) ( 5 to 12GHz)		-2.5	-3	dB
	S21  (V1=-5V;V2=-5V) ( 13 to 30GHz)		-6.5	-7.5	dB
Max Att.	S21  (V1=0V;V2=0V) (5 to 12GHz)		-25		dB
	S21  (V1=0V;V2=0V) (13 to 30GHz)		-34		dB
VSWRin	Input VSWR (any attenuation) ( 5 to 30GHz)			2.3:1	
VSWRout	Output VSWR (any attenuation) ( 8 to 30GHz)			2.5:1	
Pin1dB	Input 1dB compression point (any attenuation) (5 to 20GHz)		25		dBm
C/I3	C/I3 @ Pin/tone=12dBm (any attenuation) (up to 26GHz)		40		dB

ESD Protection : Electrostatic discharge sensitive device. Observe handling precautions !

## Absolute Maximum Ratings (1)

Tamb. = 25°C

Symbol	Parameter	Values	Unit
V1	V1 control voltage	-6V	V
V2	V2 control voltage	-6V	V
Pin	RF input power	30	dBm
Ta	Operating temperature range	-40 to +85	°C
Tstg	Storage temperature range	-55 to +155	°C

(1) Operation of this device above any one of these parameters may cause permanent damage.

## Typical Bias Conditions

for an ambient Temperature of +25°C

Symbol	Parameter	Values	Unit
V1	V1 control voltage	-5 to 0	V
V2	V2 control voltage	-5 to 0	V

## Typical results

Chip Typical Response ( On wafer Sij ) :

Tamb = +25°C

V1 = -5V & V2= -5V

*Preliminary*

Freq (GHz)	dBS11 (dB)	PhS11 (°)	dBS12 (dB)	PhS12 (°)	dBS21 (dB)	PhS21 (°)	dBS22 (dB)	PhS22 (°)
2	-6.29	-104.78	-2.01	-9.01	-1.98	-9.34	-6.22	-97.53
3	-13.90	-142.32	-1.08	-46.74	-1.04	-47.05	-13.82	-126.13
4	-33.49	103.94	-1.27	-78.74	-1.25	-79.12	-27.95	-69.61
5	-18.92	-5.76	-1.42	-104.45	-1.38	-104.65	-19.19	-18.49
6	-15.43	-27.95	-1.52	-131.80	-1.49	-131.98	-14.88	-52.69
7	-13.73	-53.65	-1.94	-155.91	-1.89	-156.07	-14.92	-74.29
8	-15.09	-68.43	-1.58	179.46	-1.55	179.18	-15.12	-102.17
9	-16.08	-74.62	-1.72	153.40	-1.68	153.18	-19.19	-140.64
10	-16.59	-73.62	-1.86	127.70	-1.80	127.51	-26.46	148.17
11	-16.95	-64.41	-2.11	103.34	-2.04	103.15	-19.90	42.75
12	-14.53	-70.07	-2.26	78.02	-2.20	77.64	-15.17	4.12
13	-13.73	-75.66	-2.50	53.37	-2.44	53.10	-12.54	-20.65
14	-12.55	-82.11	-2.82	29.21	-2.76	28.89	-10.75	-41.79
15	-11.30	-89.63	-3.08	7.21	-3.02	6.92	-9.48	-62.60
16	-11.29	-108.06	-3.06	-16.89	-3.00	-17.20	-9.80	-84.27
17	-11.56	-127.91	-3.17	-38.98	-3.12	-39.35	-10.69	-104.87
18	-14.44	-138.27	-3.19	-63.43	-3.14	-63.66	-12.57	-123.19
19	-18.03	-154.90	-3.42	-85.65	-3.37	-85.77	-17.85	-136.13
20	-31.46	-65.09	-3.15	-107.92	-3.09	-108.07	-24.60	-74.92
21	-15.91	-56.73	-3.11	-135.35	-3.06	-135.53	-15.74	-46.79
22	-11.85	-81.87	-3.65	-160.66	-3.62	-160.76	-11.06	-67.33
23	-11.09	-104.33	-4.13	176.26	-4.05	176.14	-9.92	-88.92
24	-12.09	-121.81	-4.38	153.99	-4.32	153.77	-9.57	-105.06
25	-13.45	-129.91	-4.60	130.21	-4.54	129.98	-10.03	-120.22
26	-15.14	-142.57	-4.93	105.98	-4.87	105.80	-11.49	-132.20
27	-20.61	-151.15	-4.98	81.66	-4.90	81.38	-13.59	-133.90
28	-22.21	-48.69	-5.19	53.71	-5.14	53.38	-14.94	-123.67
29	-13.40	-56.86	-5.84	26.74	-5.76	26.39	-13.19	-115.78
30	-9.33	-83.86	-6.53	1.04	-6.47	0.67	-11.12	-124.99
31	-9.26	-107.23	-6.86	-23.20	-6.81	-23.52	-10.14	-136.08
32	-9.16	-124.74	-7.10	-48.20	-7.04	-48.73	-9.70	-155.88
33	-10.96	-143.12	-6.87	-72.14	-6.79	-72.51	-11.28	-173.54
34	-15.41	-159.05	-6.31	-99.51	-6.23	-99.96	-13.59	160.74
35	-24.19	-104.04	-5.88	-128.72	-5.81	-129.15	-23.56	143.93
36	-14.66	-71.35	-5.85	-159.29	-5.77	-159.70	-22.62	-104.16
37	-10.13	-86.82	-6.58	173.48	-6.50	173.15	-13.93	-110.93
38	-8.18	-105.93	-7.22	150.56	-7.12	150.10	-11.22	-138.54
39	-7.36	-123.76	-7.60	131.28	-7.49	131.09	-10.42	-158.76
40	-7.57	-143.67	-7.27	115.53	-7.17	115.09	-9.23	176.23

V1 = 0V &amp; V2= 0V

Freq (GHz)	dBS11 (dB)	PhS11 (°)	dBS12 (dB)	PhS12 (°)	dBS21 (dB)	PhS21 (°)	dBS22 (dB)	PhS22 (°)
2	-4.44	-143.24	-19.44	-26.13	-19.40	-26.38	-2.40	-126.78
3	-7.20	-171.22	-20.89	-76.86	-20.86	-77.07	-3.79	-155.50
4	-9.10	174.49	-23.49	-113.84	-23.47	-114.12	-4.82	-173.85
5	-10.80	164.52	-25.09	-145.87	-25.05	-146.02	-5.67	172.68
6	-12.09	159.75	-26.99	-173.25	-26.95	-173.28	-6.45	162.93
7	-12.93	156.90	-28.74	160.34	-28.69	160.31	-7.04	154.27
8	-13.99	154.84	-30.05	136.61	-30.01	136.37	-7.72	147.14
9	-14.44	154.65	-31.34	112.68	-31.30	112.60	-8.25	140.61
10	-14.69	154.72	-32.15	90.56	-32.10	90.54	-8.84	134.77
11	-14.72	151.66	-33.42	71.27	-33.35	71.25	-9.35	129.86
12	-14.91	150.39	-33.25	49.61	-33.19	49.38	-10.10	125.48
13	-14.90	146.38	-34.01	29.42	-33.95	29.35	-10.42	122.02
14	-15.05	141.41	-34.69	10.49	-34.61	10.53	-10.97	117.52
15	-15.44	134.90	-35.49	-9.63	-35.42	-9.82	-11.41	113.26
16	-15.91	127.63	-35.48	-22.24	-35.33	-22.55	-11.81	108.79
17	-16.49	121.21	-35.64	-38.98	-35.50	-39.00	-12.21	104.88
18	-17.20	112.41	-37.09	-55.23	-37.06	-55.58	-12.61	98.91
19	-17.85	101.71	-35.96	-62.20	-35.97	-62.19	-13.29	95.15
20	-19.65	85.00	-34.60	-84.28	-34.55	-84.31	-14.01	90.96
21	-21.55	71.59	-35.62	-104.90	-35.48	-104.90	-14.15	88.83
22	-24.36	50.12	-35.06	-121.53	-34.97	-121.54	-14.66	83.28
23	-27.84	26.69	-34.63	-142.27	-34.55	-142.68	-14.93	81.81
24	-31.47	-8.22	-34.59	-161.79	-34.52	-162.19	-15.47	77.97
25	-33.10	-47.36	-34.97	176.00	-34.95	176.30	-15.86	74.21
26	-29.54	-67.08	-36.67	170.42	-36.60	170.40	-16.13	68.56
27	-28.46	-98.46	-35.44	152.57	-35.32	152.17	-16.87	64.47
28	-27.50	-97.94	-37.59	134.66	-37.42	134.22	-16.78	62.16
29	-26.66	-105.16	-37.41	137.29	-37.37	136.97	-17.33	59.71
30	-24.45	-120.07	-36.45	118.83	-36.43	118.60	-17.65	62.80
31	-24.56	-139.96	-38.67	102.14	-38.69	101.74	-17.51	57.70
32	-25.41	-148.35	-38.96	107.86	-38.89	107.48	-17.68	60.32
33	-25.09	-152.31	-38.69	93.25	-38.58	93.33	-17.01	50.49
34	-26.83	-175.25	-39.68	75.15	-39.48	75.61	-16.68	54.96
35	-28.46	168.50	-44.22	42.32	-44.23	40.54	-16.74	48.74
36	-27.53	140.64	-57.99	14.39	-57.42	15.21	-15.91	53.83
37	-27.82	106.98	-51.31	-100.68	-51.46	-100.36	-15.24	45.02
38	-26.79	80.89	-40.98	-130.65	-40.84	-130.90	-14.40	42.19
39	-25.83	57.55	-35.91	-158.28	-35.85	-158.46	-14.25	35.29
40	-21.50	51.16	-32.54	-174.93	-32.44	-174.88	-13.39	44.33

## Typical Results on wafer

Tamb = +25°C

*Preliminary*

### Attenuation versus frequency

V1 = -5V to 0V & V2 = -5V and after V1 = 0V & V2 = -5V to 0V

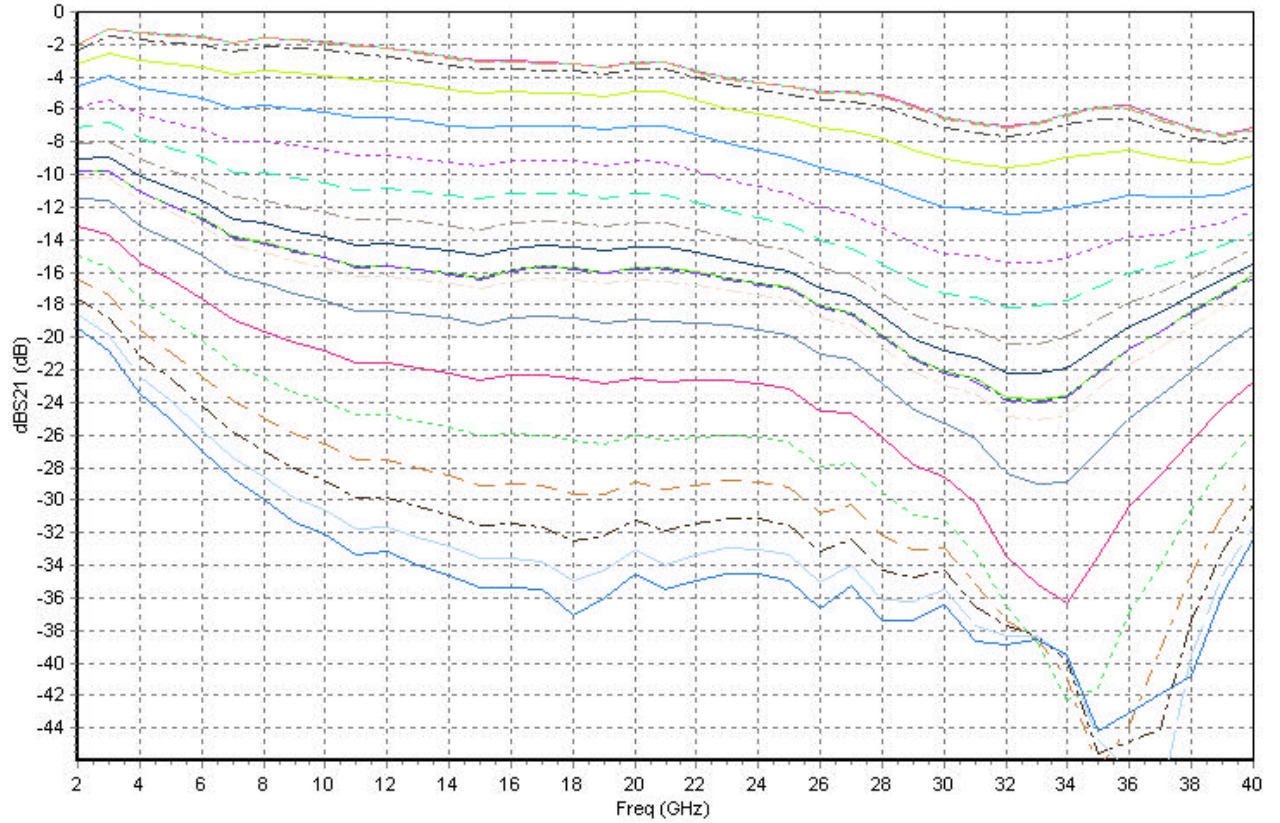

Input Return loss versus frequency in total attenuation range

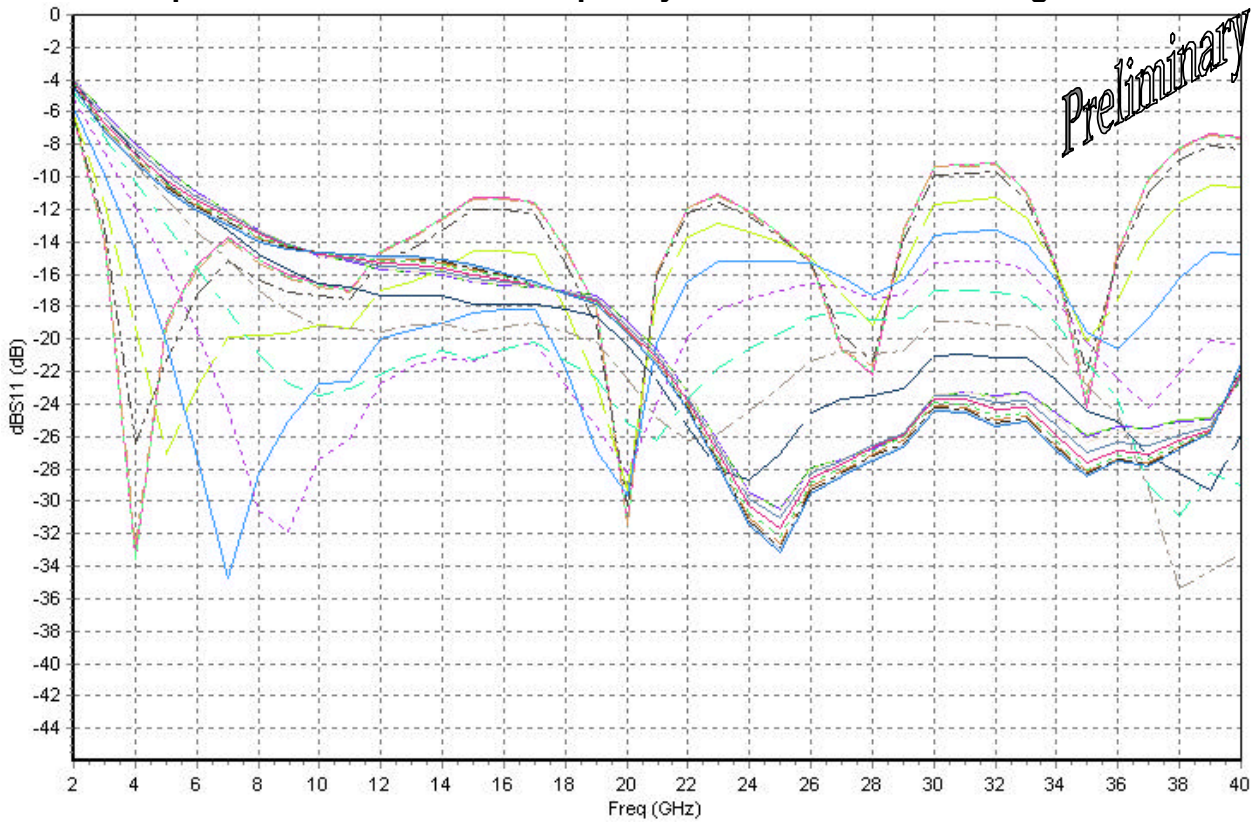

Output Return loss versus frequency in total attenuation range

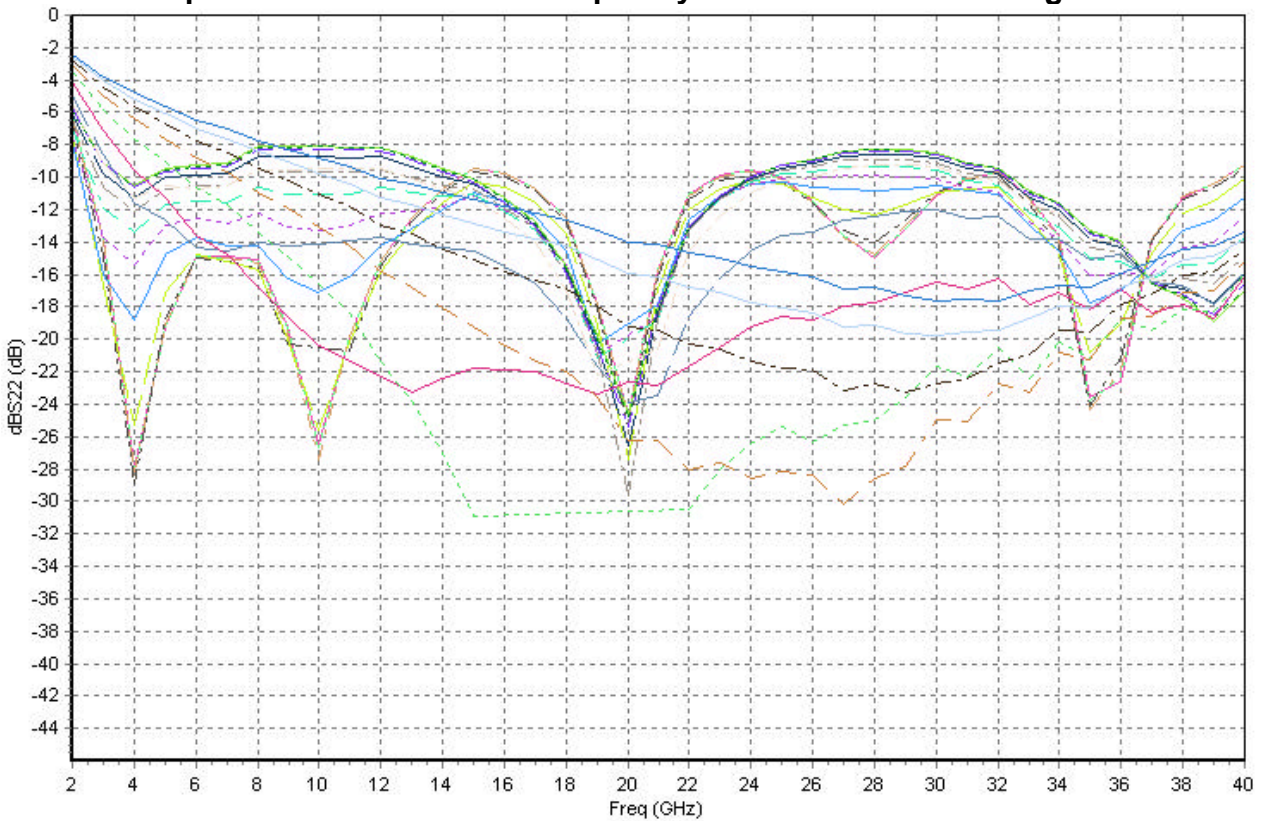

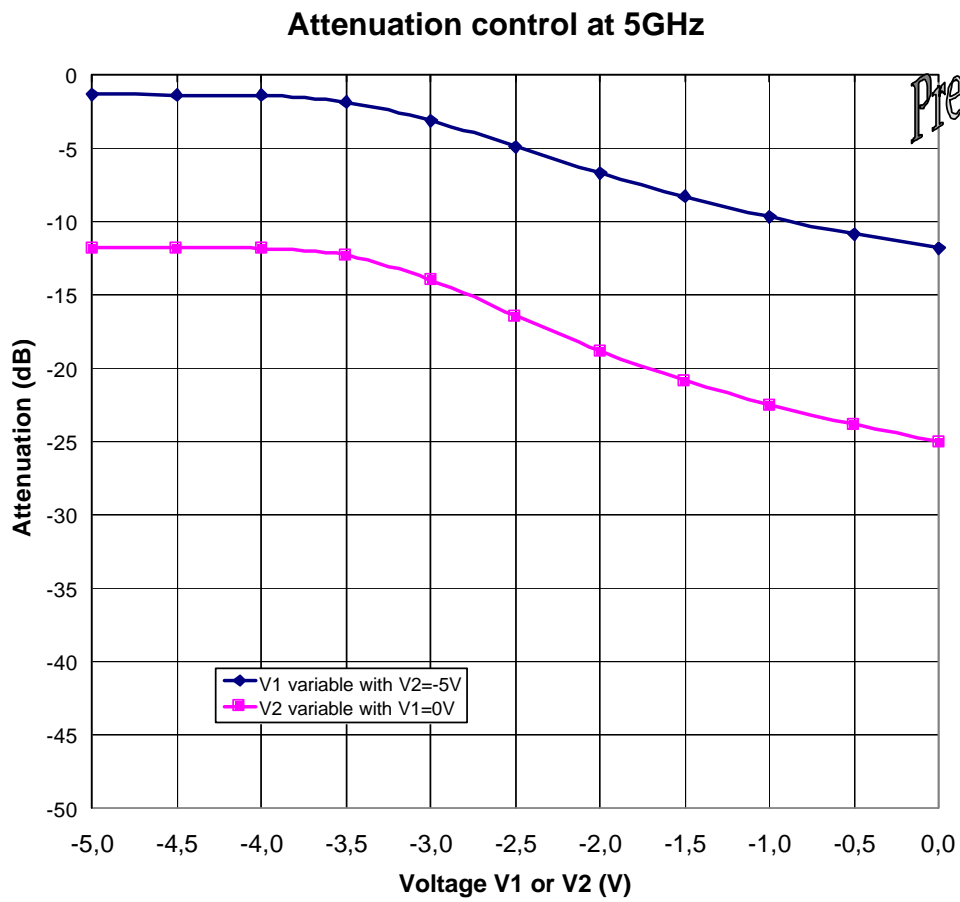

### Attenuation control at 15GHz

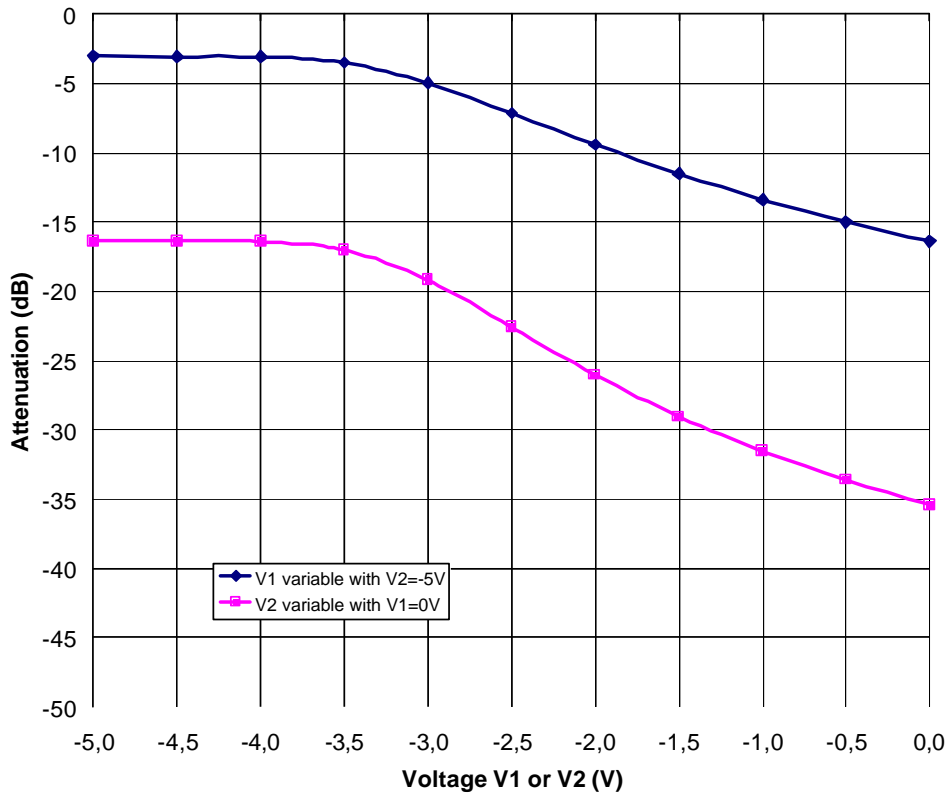

Attenuation control at 25GHz

*Preliminary*

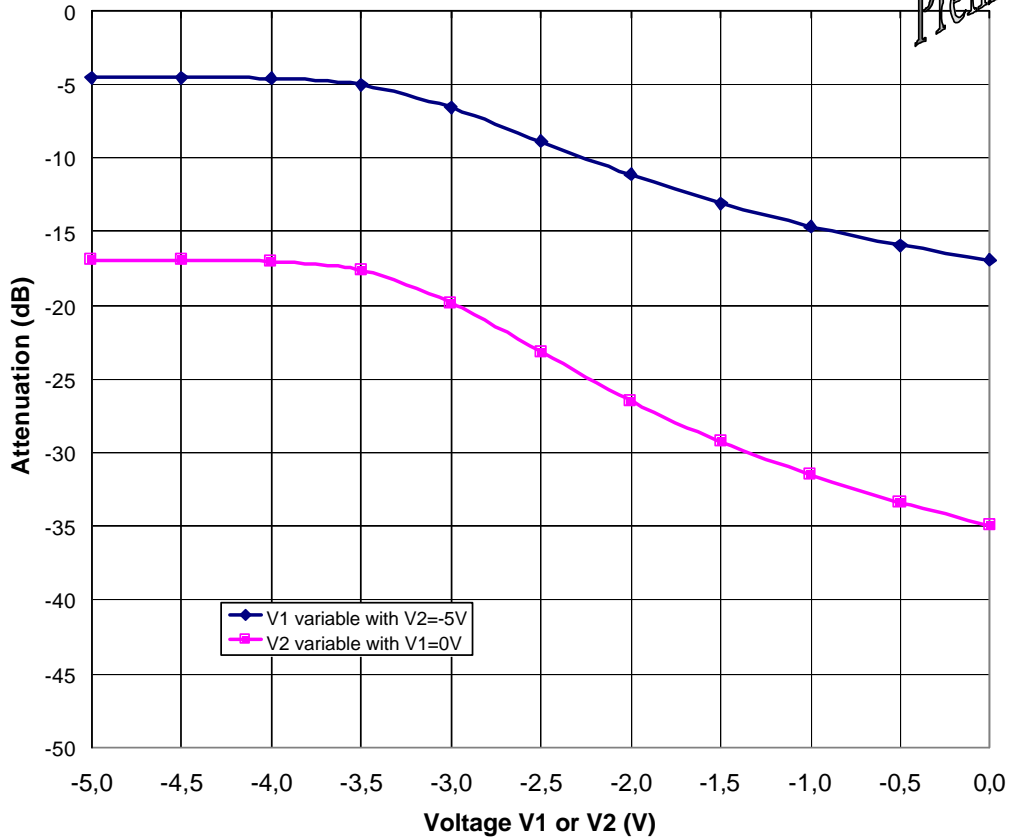



### Attenuation versus input power @ 20GHz

V1 = -5V to 0V & V2= -5V and after V1= 0V & V2 = -5V to 0V

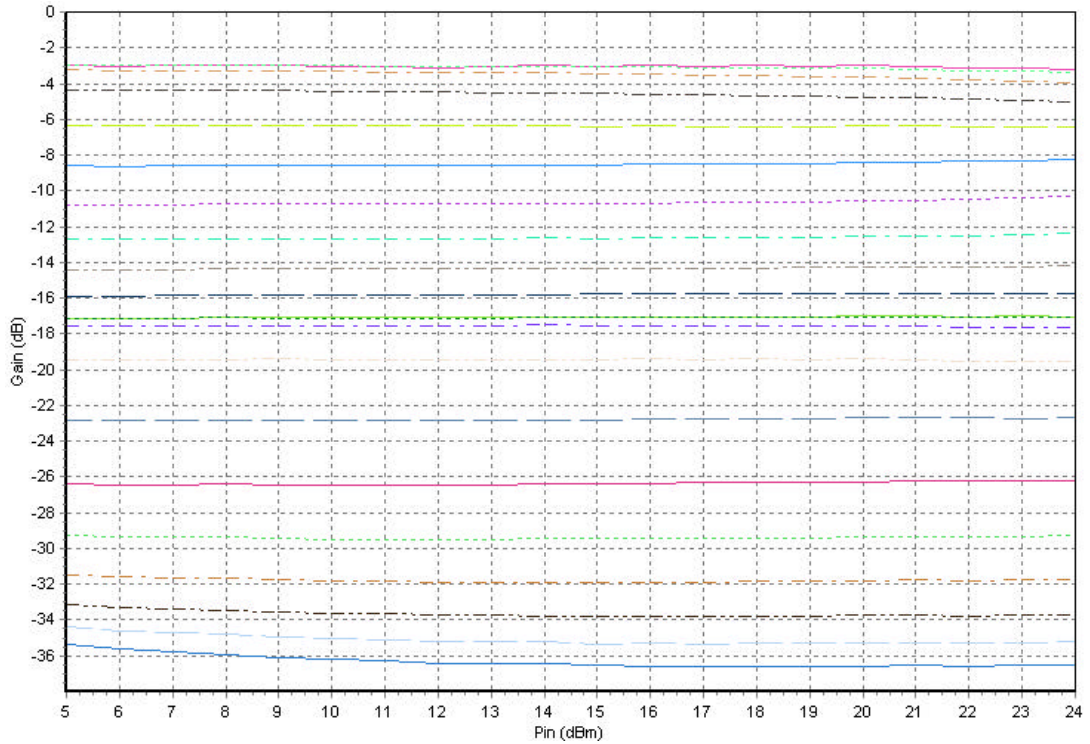

### Input IP3 versus input power

V1 = -3.5V & V2= -5V (worst case area for the linearity)

*Preliminary*

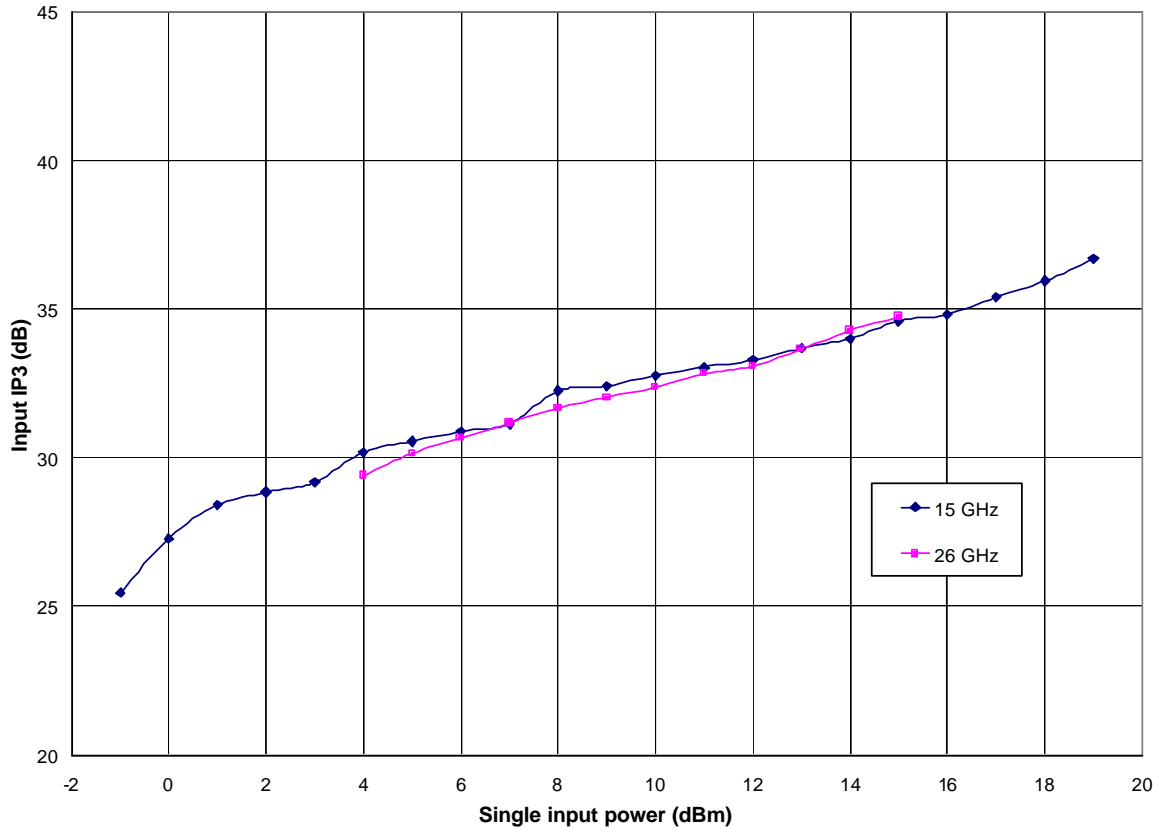

**C/I3 versus input power**

V1 = -3.5V & V2 = -5V (worst case area for the linearity)

*Preliminary*

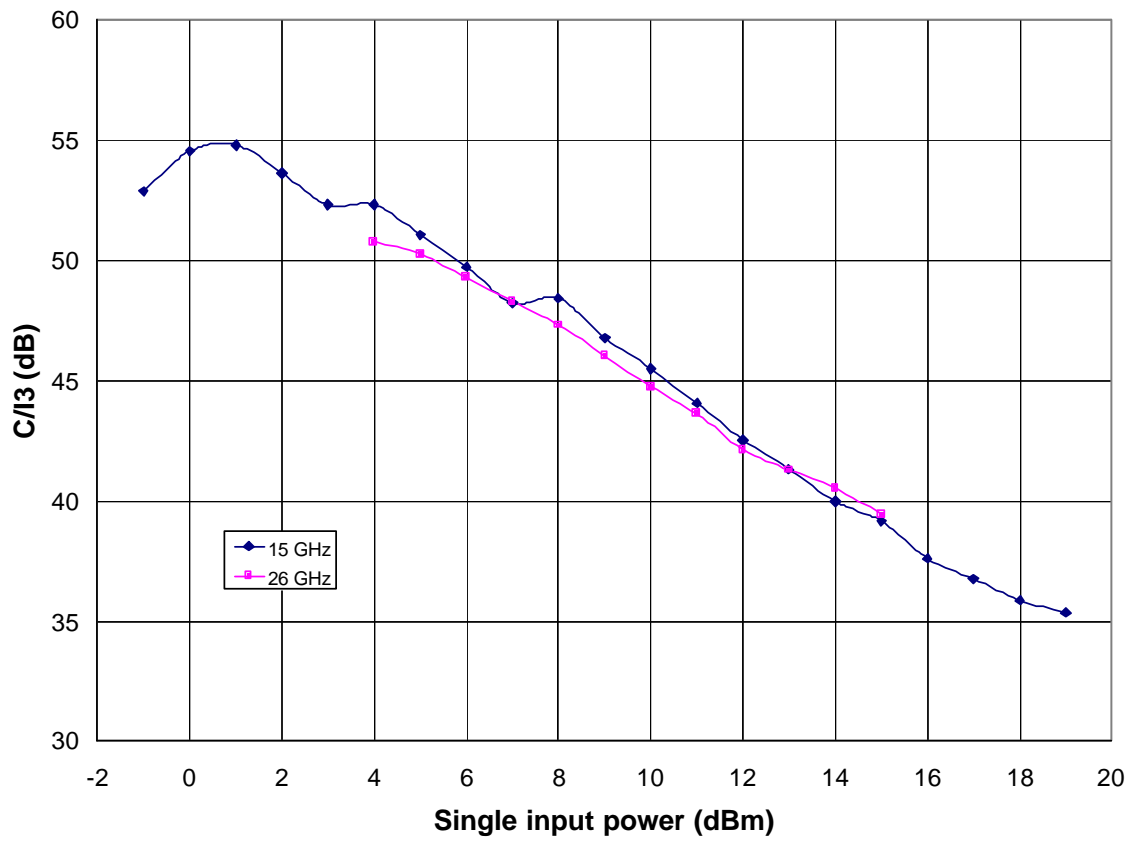

*Preliminary***Biasing sequence**

To obtain good performances in linearity, biasing voltage should be applied as following:

- Control of 1<sup>st</sup> stage attenuation with V1 from -5V to 0V, with V2 fixed at -5V
- Control of 2<sup>nd</sup> stage with V2 from -5V to 0V, with V1 fixed at 0V

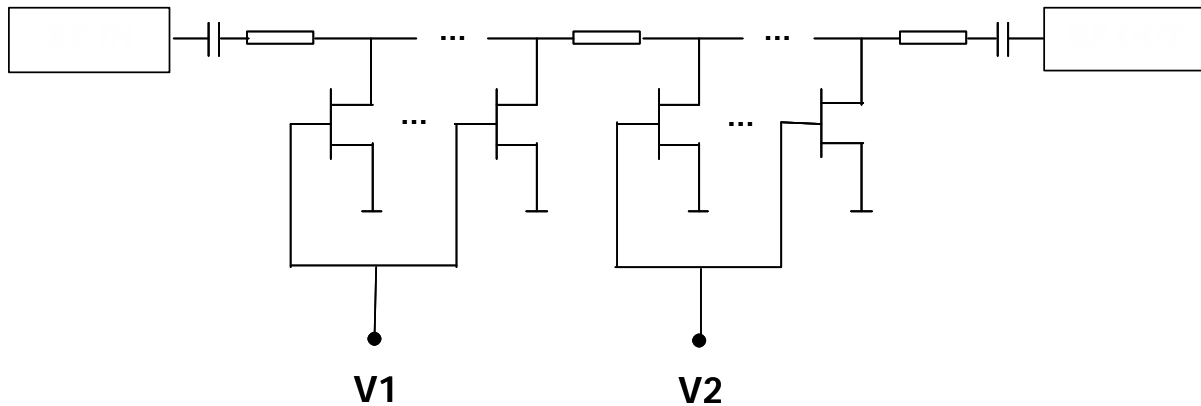
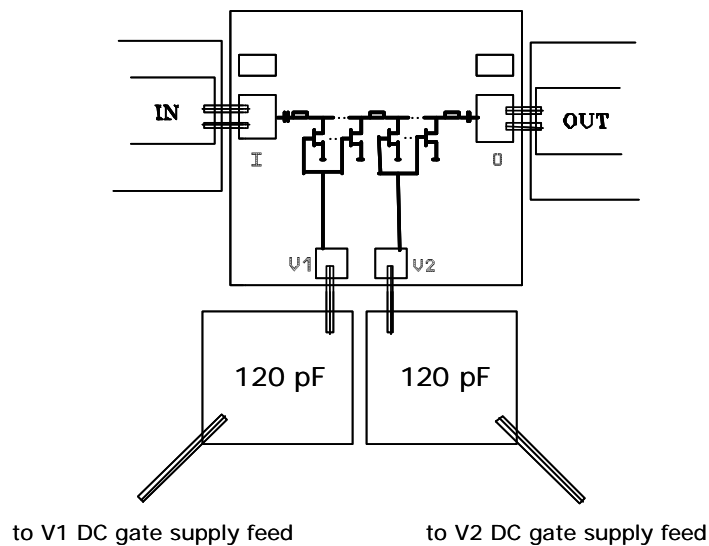
**Chip Assembly and Mechanical Data**

Note : Supply feed might be capacitively bypassed. 25 $\mu$ m diameter gold wire is to be preferred.

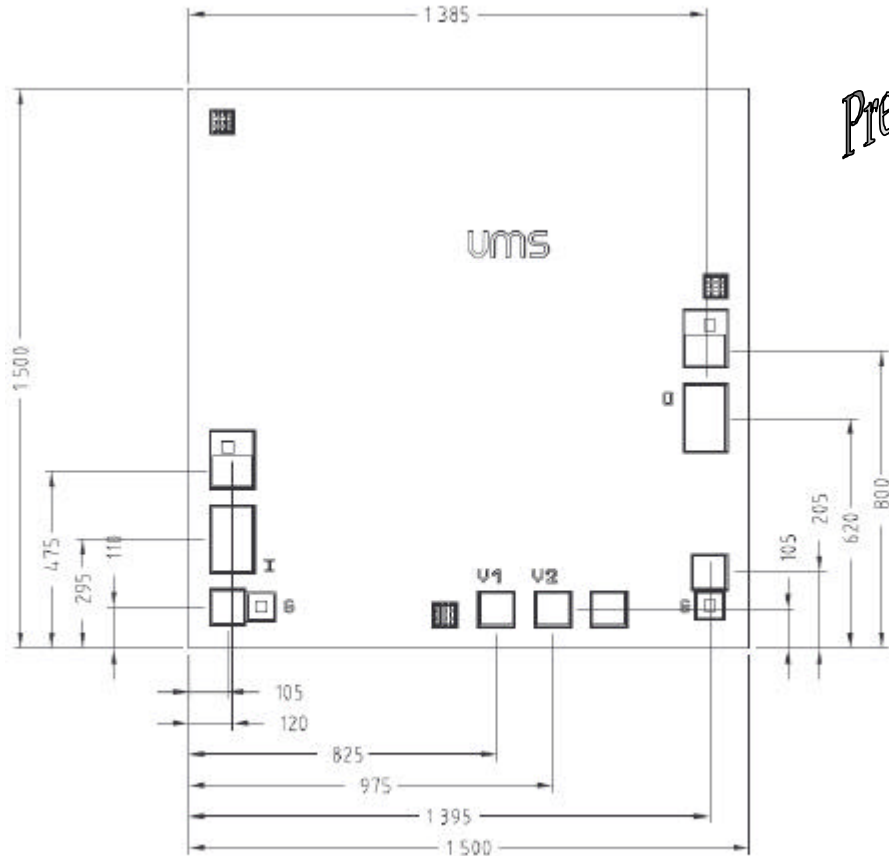

UNITS :  $\mu\text{m}$   
 Tol :  $\pm 35\mu\text{m}$

**Bonding pad positions.**

( Chip thickness : 100 $\mu\text{m}$ . All dimensions are in micrometers )

**Ordering Information**

Chip form : CHT4690-99F/00

Information furnished is believed to be accurate and reliable. However **United Monolithic Semiconductors S.A.S.** assumes no responsibility for the consequences of use of such information nor for any infringement of patents or other rights of third parties which may result from its use. No license is granted by implication or otherwise under any patent or patent rights of **United Monolithic Semiconductors S.A.S.** Specifications mentioned in this publication are subject to change without notice. This publication supersedes and replaces all information previously supplied. **United Monolithic Semiconductors S.A.S.** products are not authorised for use as critical components in life support devices or systems without express written approval from **United Monolithic Semiconductors S.A.S.**