

### Typical Applications

This HMC-ALH382 is ideal for:

- Short Haul / High Capacity Links
- Wireless LANs
- Military & Space

### Features

- Noise Figure: 3.8 dB
- P1dB: +12 dBm
- Gain: 21 dB
- Supply Voltage: +2.5V
- 50 Ohm Matched Input/Output
- Die Size: 1.55 x 0.73 x 0.1 mm

### Functional Diagram

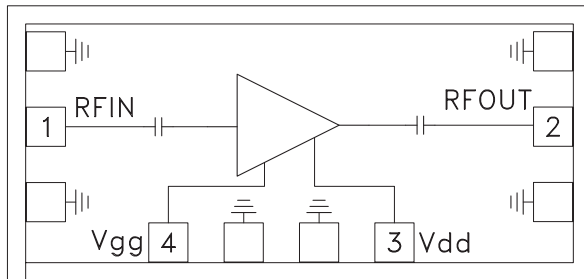

### General Description

The HMC-ALH382 is a high dynamic range, four stage GaAs HEMT MMIC Low Noise Amplifier (LNA) which operates between 57 and 65 GHz. The HMC-ALH382 features 21 dB of small signal gain, 4 dB of noise figure and an output power of +12 dBm at 1dB compression from a +2.5V supply voltage. All bond pads and the die backside are Ti/Au metallized and the amplifier device is fully passivated for reliable operation. This versatile LNA is compatible with conventional die attach methods, as well as thermocompression and thermosonic wirebonding, making it ideal for MCM and hybrid microcircuit applications. All data shown herein is measured with the chip in a 50 Ohm environment and contacted with RF probes.

### Electrical Specifications, $T_A = +25^\circ C$ , $V_{dd} = 2.5V$ , $I_{dd} = 64 mA^*$

Parameter	Min.	Typ.	Max.	Units
Frequency Range		57 - 65		GHz
Gain	19	21		dB
Noise Figure		4	5.5	dB
Input Return Loss		12		dB
Output Return Loss		10		dB
Output Power for 1 dB Compression (P1dB)		12		dBm
Supply Current ( $I_{dd}$ )( $V_{dd} = 2.5V, V_{gg} = -0.3V$ Typ.)		64	100	mA

\*Unless otherwise indicated, all measurements are from probed die  
 [2] Adjust Vgg between -1V to +0.3V (Typ. -0.2V) to achieve  $I_{dd_{total}} = 64 mA$

**Linear Gain vs. Frequency**

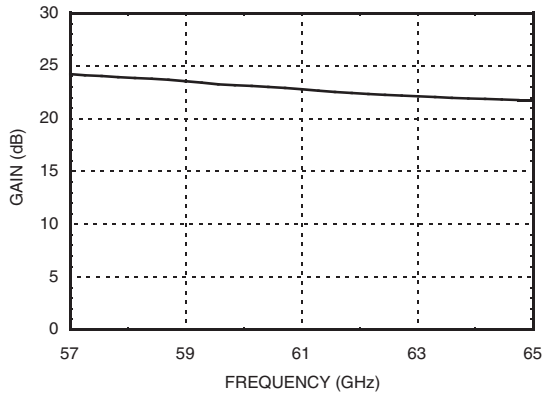

**Noise Figure vs. Frequency**

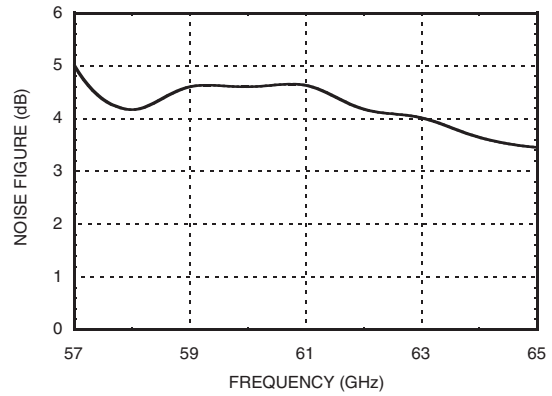

**Input Return Loss vs. Frequency**

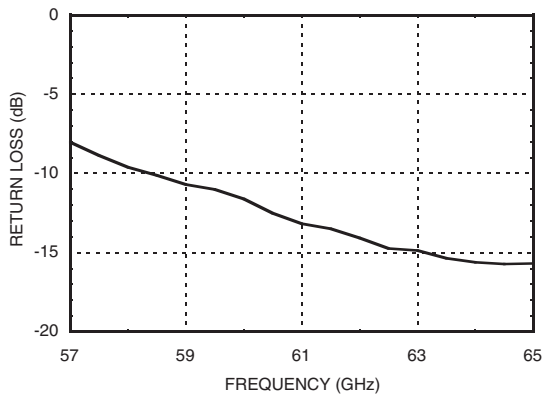

**Output Return Loss vs. Frequency**

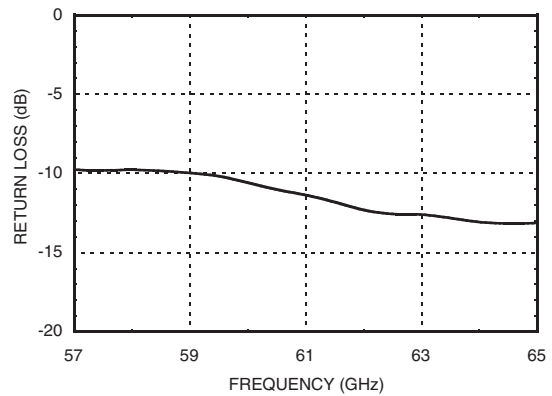

**Wideband Linear Gain**

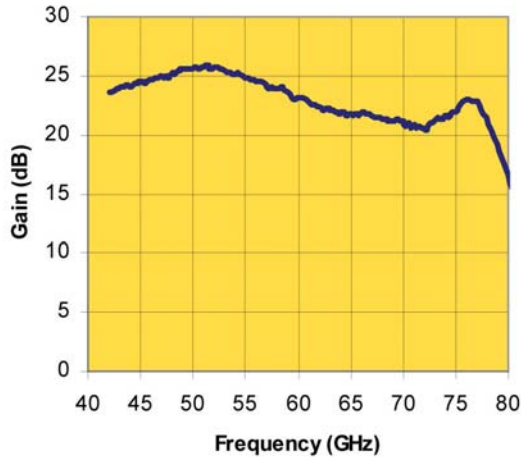

**Wideband Input Return Loss**

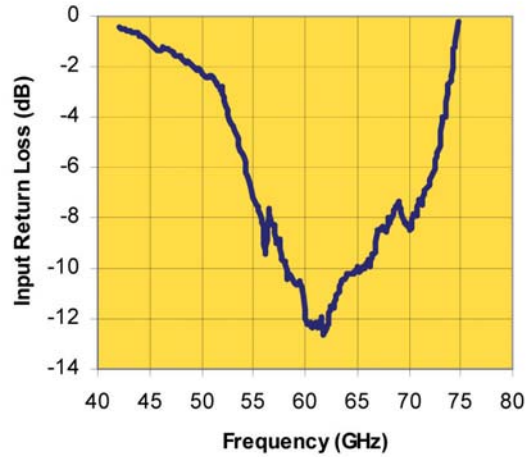

**Wideband Output Return Loss**

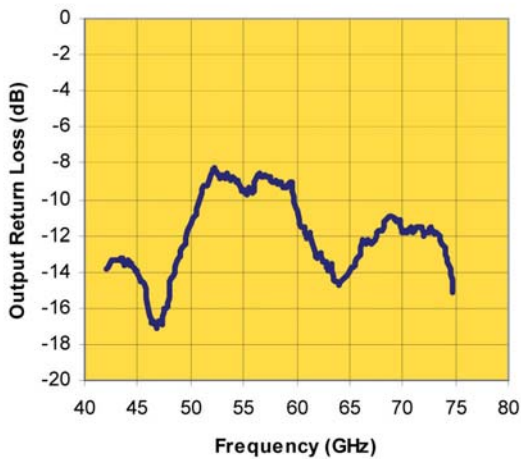

**Absolute Maximum Ratings**

Drain Bias Voltage	+5.5 Vdc
Gate Bias Voltage	-1 to +0.3 Vdc
RF Input Power	-5 dBm
Storage Temperature	-65 to +150 °C
Operating Temperature	-55 to +85 °C



ELECTROSTATIC SENSITIVE DEVICE  
OBSERVE HANDLING PRECAUTIONS

**Outline Drawing**

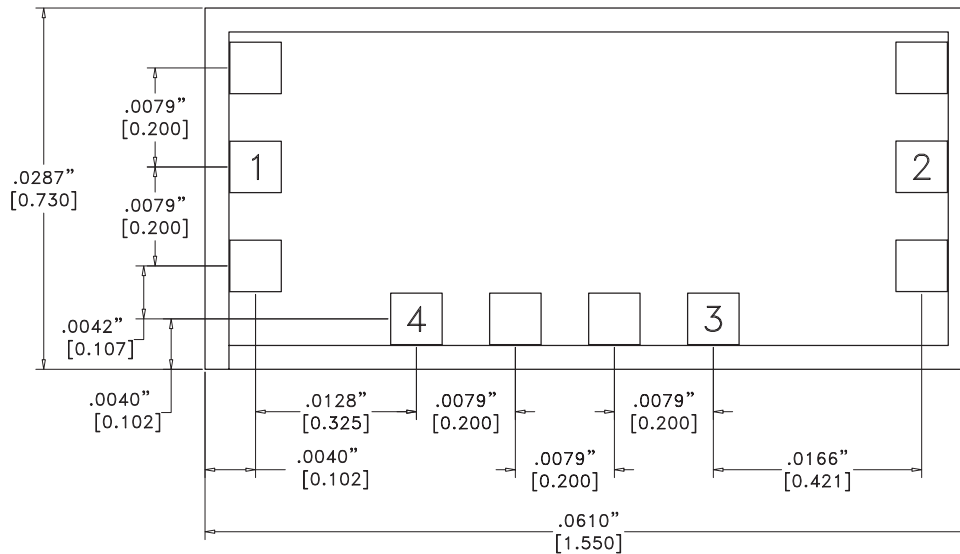

**Die Packaging Information <sup>[1]</sup>**

Standard	Alternate
WP - 8	[2]



[1] Refer to the "Packaging Information" section for die packaging dimensions.

[2] For alternate packaging information contact Hittite Microwave Corporation.

NOTES:

1. ALL DIMENSIONS ARE IN INCHES [MM].
2. TYPICAL BOND PAD IS .004" SQUARE.
3. BACKSIDE METALLIZATION: GOLD.
4. BACKSIDE METAL IS GROUND.
5. BOND PAD METALLIZATION: GOLD.
6. CONNECTION NOT REQUIRED FOR UNLABELED BOND PADS.
7. OVERALL DIE SIZE ±.002"

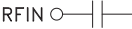
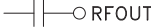
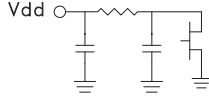
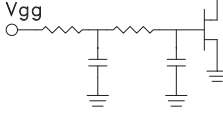
**Pad Descriptions**

Pad Number	Function	Description	Interface Schematic
1	RFIN	This pad is AC coupled and matched to 50 Ohms.	
2	RFOUT	This pad is AC coupled and matched to 50 Ohms.	
3	Vdd	Power Supply Voltage for the amplifier. See assembly for required external components.	
4	Vgg	Gate control for amplifier. Please follow "MMIC Amplifier Biasing Procedure" application note. See assembly for required external components.	
Die bottom	GND	Die bottom must be connected to RF/DC ground.	

**Assembly Diagram**

