



32-Tap Digital Up/Down Control Potentiometer

FEATURES

- 32-position linear taper potentiometer
- Low power CMOS technology
- Single supply operation: 2.5V – 5.5V
- Discrete step-up/step-down digital control
- Resistance values: 10kΩ, 50kΩ and 100kΩ
- Available in SOT-23 8-lead Pb-free package

APPLICATIONS

- Automated product calibration
- Remote control adjustments
- Offset, gain and zero control
- Tamper-proof calibrations
- Contrast, brightness and volume controls
- Motor controls and feedback systems
- Programmable analog functions

For Ordering Information details, see page 7.

DESCRIPTION

The CAT5128 is a single digitally programmable potentiometer (DPP™) designed as an electronic replacement for mechanical potentiometers and trim pots. Ideal for automated adjustments on high volume production lines, they are also well suited for applications where equipment requiring periodic adjustment is either difficult to access or located in a hazardous or remote environment.

The CAT5128 contains a 32-tap series resistor array connected between two terminals A and B. An up/down counter and decoder that are controlled by two input pins, determines which tap is connected to the wiper, W. Wiper-control of the CAT5128 is accomplished with two input control pins, \overline{UP} and \overline{DOWN} . A high-to-low transition on the \overline{UP} input increments the wiper position and a high-to-low transition on the \overline{DOWN} input decrements the wiper position. The tap position is not stored in memory. The wiper is always set to the mid point, tap 15 at power up.

The digitally programmable potentiometer can be used as a three-terminal resistive divider or as a two-terminal variable resistor. DPPs bring variability and programmability to a wide variety of applications including control, parameter adjustments, and signal processing.

FUNCTIONAL DIAGRAM

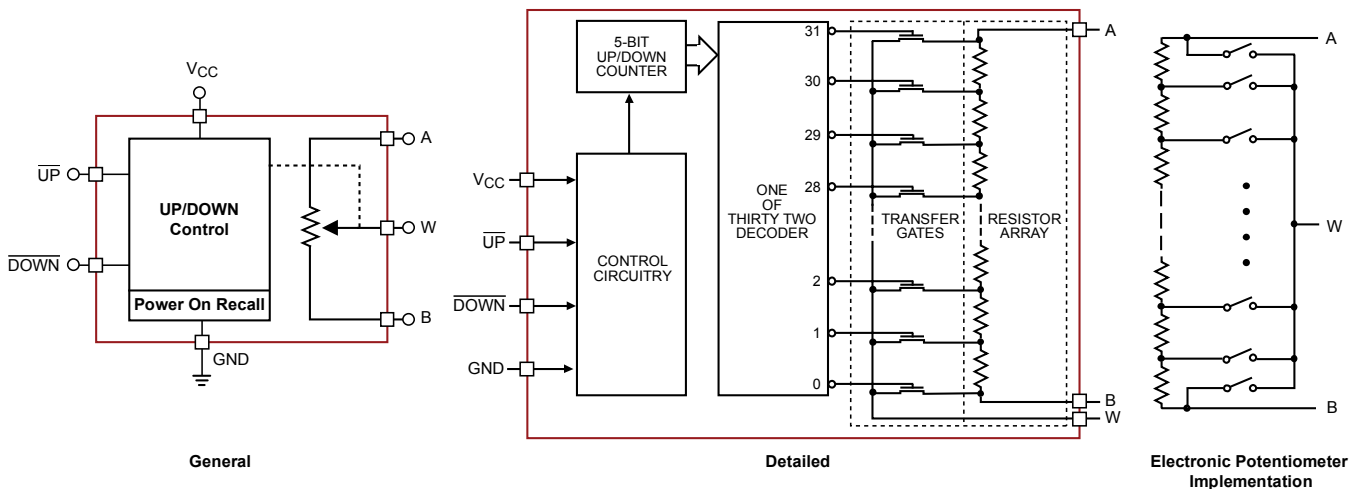

PIN CONFIGURATION

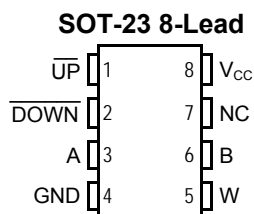

PIN DESCRIPTION

UP̄: Step-Up Control Input

When DOWN input is high, a high-to-low transition on UP input will cause the wiper to move one increment toward the A terminal.

DOWN: Step-Down Control Input

A high-to-low transition on DOWN input will cause the wiper to move one increment towards the B terminal.

A: High End Potentiometer Terminal

A is the high end terminal of the potentiometer. It is not required that this terminal be connected to a potential greater than the B terminal. Voltage applied to the A terminal cannot exceed the supply voltage, V_{CC} or go below ground, GND.

W: Wiper Potentiometer Terminal

W is the wiper terminal of the potentiometer. Its position on the resistor array is controlled by the control inputs, UP and DOWN. Voltage applied to the W terminal cannot exceed the supply voltage, V_{CC} or go below ground, GND.

B: Low End Potentiometer Terminal

B is the low end terminal of the potentiometer. It is not required that this terminal be connected to a potential less than the A terminal. Voltage applied to the B terminal cannot exceed the supply voltage, V_{CC} or go below ground, GND. B and A are electrically interchangeable.

PIN DESCRIPTIONS

Name	Function
UP̄	Step-Up Control
DOWN	Step-Down Control
A	Potentiometer High Terminal
GND	Ground
W	Wiper Terminal
B	Potentiometer Low Terminal
NC	Not Connected
V _{CC}	Supply Voltage

DEVICE OPERATION

The CAT5128 operates like a digitally controlled potentiometer with A and B equivalent to the high and low terminals and W equivalent to the mechanical potentiometer's wiper. There are 32 available tap positions including the resistor end points, A and B. There are 31 resistor elements connected in series between the A and B terminals. The wiper terminal is connected to one of the 32 taps and controlled by two inputs, UP and DOWN. These inputs control a five-bit up/down counter whose output is decoded to select the wiper position.

A high-to-low transition on DOWN input will decrement one step the wiper position (R_{WB} will decrease with 1LSB and R_{WA} will increase with 1LSB). If and only if DOWN input is high, a high-to-low transition on UP input will increment one step the wiper position (R_{WB} will increase with 1LSB and R_{WA} will decrease with 1LSB).

The wiper, when at either fixed terminal, acts like its mechanical equivalent and does not move beyond the last position. When the CAT5128 is powered-down, the wiper position is reset. When power is restored, the counter is set to the mid point, tap 15.

OPERATION MODES

\overline{UP}	\overline{DOWN}	Operation
High to Low	High	Wiper toward A – R_W Increment
X	Low	Wiper does not change
High	High to Low	Wiper toward B – R_W Decrement
High to Low	High to Low	Wiper toward B – R_W Decrement
Low	X	Wiper does not change
High	High	Wiper does not change

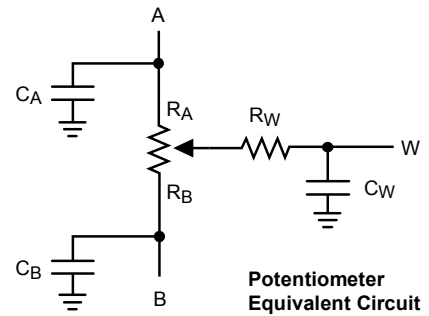

ABSOLUTE MAXIMUM RATINGS ⁽¹⁾

Parameters	Ratings	Units
Supply Voltage V_{CC} to GND	-0.5 to +7V	V
Inputs \overline{UP} to GND	-0.5 to $V_{CC} + 0.5$	V
\overline{DOWN} to GND	-0.5 to $V_{CC} + 0.5$	V
A, B, W to GND	-0.5 to $V_{CC} + 0.5$	V
Operating Ambient Temperature Industrial ('I' suffix)	-40 to +85	°C
Junction Temperature	+150	°C
Storage Temperature	-65 to 150	°C
Lead Soldering (10 seconds max)	+300	°C
Thermal Resistance θ_{JA}	230	°C/W

DC ELECTRICAL CHARACTERISTICS

$V_{CC} = +2.5V$ to $+5.5V$ unless otherwise specified

Power Supply

Symbol	Parameter	Conditions	Min	Typ	Max	Units
V_{CC}	Operating Voltage Range		2.5	–	5.5	V
I_{CC1}	Supply Current (Increment)	$V_{CC} = 5.5V, f = 1MHz, I_W = 0$	–	–	100	μA
		$V_{CC} = 5.5V, f = 250kHz, I_W = 0$	–	–	50	μA
$I_{SB1}^{(3)}$	Supply Current (Standby)	$\overline{UP}, \overline{DOWN} = V_{CC}$ or GND	–	0.01	1	μA

Notes:

- (1) Stresses above those listed under “Absolute Maximum Ratings” may cause permanent damage to the device. These are stress ratings only, and functional operation of the device at these or any other conditions outside of those listed in the operational sections of this specification is not implied. Exposure to any absolute maximum rating for extended periods may affect device performance and reliability.

LOGIC INPUTS

$V_{CC} = +2.5V$ to $+5.5V$ unless otherwise specified

Symbol	Parameter	Conditions	Min	Typ	Max	Units
I_{IH}	Input Leakage Current	$V_{IN} = V_{CC}$	–	–	10	μA
I_{IL}	Input Leakage Current	$V_{IN} = 0V$	–	–	-10	μA
V_{IH1}	TTL High Level Input Voltage	$4.5V \leq V_{CC} \leq 5.5V$	2	–	V_{CC}	V
V_{IL1}	TTL Low Level Input Voltage		0	–	0.8	V
V_{IH2}	CMOS High Level Input Voltage	$2.5V \leq V_{CC} \leq 5.5V$	$V_{CC} \times 0.7$	–	$V_{CC} + 0.3$	V
V_{IL2}	CMOS Low Level Input Voltage		-0.3	–	$V_{CC} \times 0.2$	V

POTENTIOMETER CHARACTERISTICS

$V_{CC} = +2.5V$ to $+5.5V$ unless otherwise specified

Symbol	Parameter	Conditions	Min	Typ ⁽¹⁾	Max	Units
R_{POT}	Potentiometer Resistance	-10 Device		10		k Ω
		-50 Device		50		
		-00 Device		100		
	Pot. Resistance Tolerance				± 20	%
V_A	Voltage on A pin		0		V_{CC}	V
V_B	Voltage on B pin		0		V_{CC}	V
	Resolution			3.2		%
INL	Integral Linearity Error	$I_W \leq 2\mu A$	-0.5	0.1	0.5	LSB
DNL	Differential Linearity Error	$I_W \leq 2\mu A$	-0.5	0.05	0.5	LSB
R_{WI}	Wiper Resistance	$V_{CC} = 5V, I_W = 1mA$		70		Ω
		$V_{CC} = 2.5V, I_W = 1mA$		150	300	Ω
I_W	Wiper Current	(2)			1	mA
TC_{RPOT}	TC of Pot Resistance	(3)		50		ppm/ $^{\circ}C$
TC_{RATIO}	Ratiometric TC	(3)		5	20	ppm/ $^{\circ}C$
$V_N^{(3)}$	Noise	100kHz / 1kHz		8/24		nV/ \sqrt{Hz}
$C_A/C_B/C_W$	Potentiometer Capacitances	(3)		8/8/25		pF
fc (3)	Frequency Response	Passive Attenuator, 10k Ω		1.7		MHz

Notes:

- (1) Typical values are for $T_A = 25^{\circ}C$ and nominal supply voltage.
 (2) I_W = source or sink.
 (3) These parameters are periodically sampled and are not production tested.

AC CONDITIONS OF TEST

V _{CC} Range	2.5V ≤ V _{CC} ≤ 5.5V
Input Pulse Levels	0.2V _{CC} to 0.7V _{CC}
Input Rise and Fall Times	10ns
Input Reference Levels	0.5V _{CC}

AC OPERATING CHARACTERISTICS

V_{CC} = +2.5V to +5.5V, V_H = V_{CC}, V_L = 0V, unless otherwise specified

Symbol	Parameter	Min	Typ ⁽¹⁾	Max	Units
t _{UP}	\overline{UP} LOW Period	500	–	–	ns
t _{DOWN}	\overline{DOWN} LOW Period	500	–	–	ns
t _{UP_CYC}	\overline{UP} Cycle Time	1	–	–	μs
t _{DOWN_CYC}	\overline{DOWN} Cycle Time	1	–	–	μs
t _{UP_R} , t _{UP_F} ⁽²⁾	\overline{UP} Rise and Fall Time	–	–	500	ns
t _{DOWN_R} , t _{DOWN_F} ⁽²⁾	\overline{DOWN} Rise and Fall Time	–	–	500	ns
t _{UP_SET}	\overline{UP} Settling Time	200	–	–	ns
t _{DOWN_SET}	\overline{DOWN} Settling Time	200	–	–	ns
t _{PU} ⁽²⁾	Power-up to Wiper Stable	–	–	1	ms

INTERFACE TIMING DIAGRAM

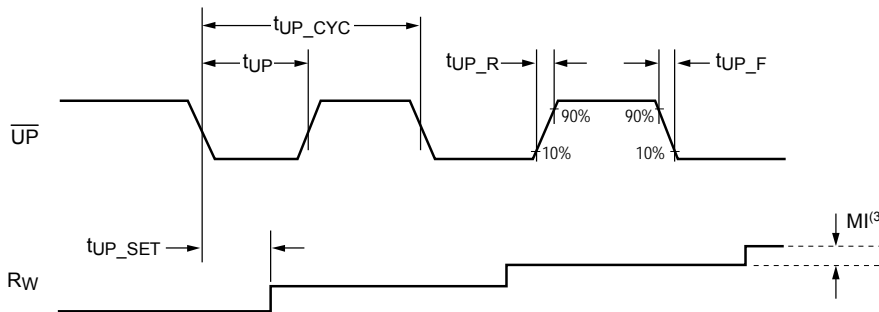

Increment R_w in Discrete Steps

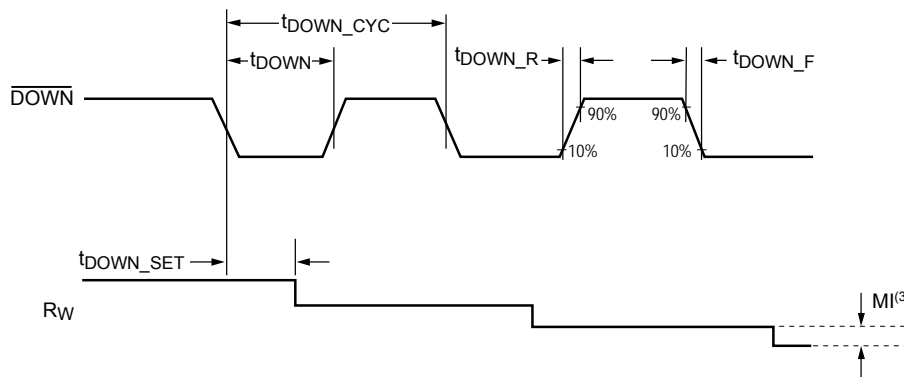

Decrement R_w in Discrete Steps

Notes:

- (1) Typical values are for T_A = 25°C and nominal supply voltage.
- (2) This parameter is periodically sampled and not 100% tested.
- (3) MI in the A.C. Timing diagram refers to the minimum incremental change in the W output due to a change in the wiper position.

PACKAGE OUTLINE DRAWING

SOT-23 8-Lead (TB) ⁽¹⁾⁽²⁾

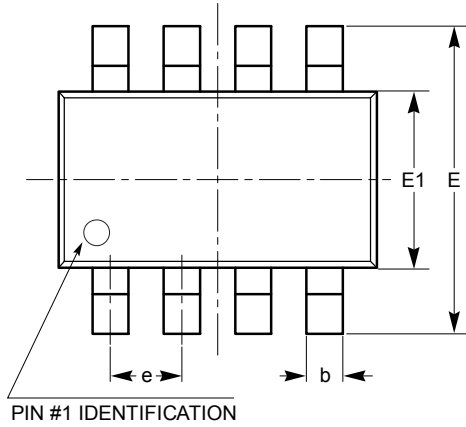

TOP VIEW

SYMBOL	MIN	NOM	MAX
A	0.90		1.45
A1	0.00		0.15
A2	0.90	1.10	1.30
A3	0.60		0.80
b	0.28		0.38
c	0.08		0.22
D	2.90 BSC		
E	2.80 BSC		
E1	1.60 BSC		
e	0.65 BSC		
L	0.30	0.45	0.60
L1	0.60 REF		
L2	0.25 REF		
θ	0°		8°

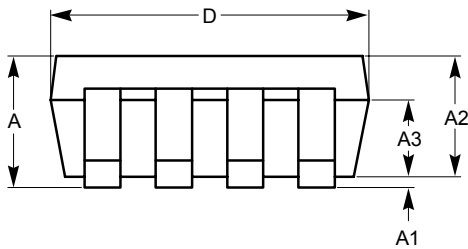

SIDE VIEW

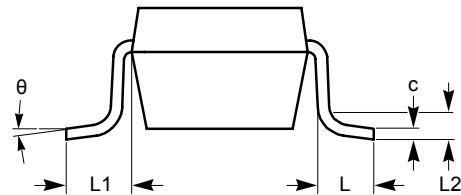

END VIEW

For current Tape and Reel information, download the PDF file from:
<http://www.catsemi.com/documents/tapeandreel.pdf>.

Notes:

- (1) All dimensions are in millimeters.
- (2) Complies with JEDEC standard MO-178.

EXAMPLE OF ORDERING INFORMATION

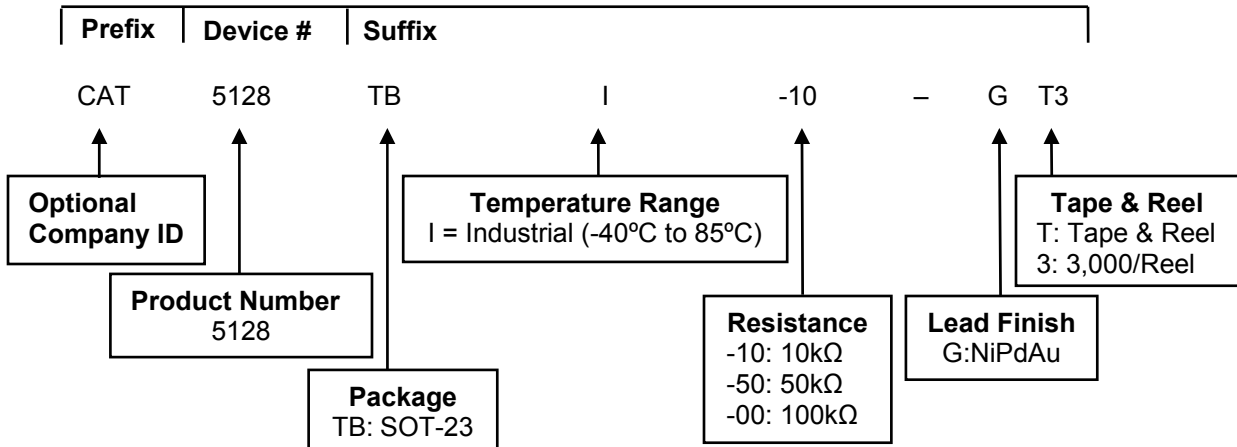

ORDERING PART NUMBER

	Resistance	Package
CAT5128TBI-10	10kΩ	SOT-23-8
CAT5128TBI-50	50kΩ	
CAT5128TBI-00 ⁽⁵⁾	100kΩ	

For Product Top Mark Codes, click here:
<http://www.catsemi.com/techsupport/producttopmark.asp>

Notes:

- (1) All packages are RoHS-compliant (Lead-free, Halogen-free).
- (2) The standard lead finish is NiPdAu.
- (3) This device used in the above example is a CAT5128TBI-10-GT3 (SOT-23, Industrial Temperature, 10kΩ, NiPdAu, Tape & Reel, 3,000/Reel) .
- (4) For additional package and temperature options, please contact your nearest Catalyst Semiconductor Sales office.
- (5) Contact factory for availability.

REVISION HISTORY

Date	Rev.	Reason
03/19/08	A	Initial Release

Copyrights, Trademarks and Patents

© Catalyst Semiconductor, Inc.

Trademarks and registered trademarks of Catalyst Semiconductor include each of the following:

Adaptive Analog™, Beyond Memory™, DPP™, EZDim™, LDD™, MiniPot™, Quad-Mode™ and Quantum Charge Programmable™

Catalyst Semiconductor has been issued U.S. and foreign patents and has patent applications pending that protect its products.

CATALYST SEMICONDUCTOR MAKES NO WARRANTY, REPRESENTATION OR GUARANTEE, EXPRESS OR IMPLIED, REGARDING THE SUITABILITY OF ITS PRODUCTS FOR ANY PARTICULAR PURPOSE, NOR THAT THE USE OF ITS PRODUCTS WILL NOT INFRINGE ITS INTELLECTUAL PROPERTY RIGHTS OR THE RIGHTS OF THIRD PARTIES WITH RESPECT TO ANY PARTICULAR USE OR APPLICATION AND SPECIFICALLY DISCLAIMS ANY AND ALL LIABILITY ARISING OUT OF ANY SUCH USE OR APPLICATION, INCLUDING BUT NOT LIMITED TO, CONSEQUENTIAL OR INCIDENTAL DAMAGES.

Catalyst Semiconductor products are not designed, intended, or authorized for use as components in systems intended for surgical implant into the body, or other applications intended to support or sustain life, or for any other application in which the failure of the Catalyst Semiconductor product could create a situation where personal injury or death may occur.

Catalyst Semiconductor reserves the right to make changes to or discontinue any product or service described herein without notice. Products with data sheets labeled "Advance Information" or "Preliminary" and other products described herein may not be in production or offered for sale.

Catalyst Semiconductor advises customers to obtain the current version of the relevant product information before placing orders. Circuit diagrams illustrate typical semiconductor applications and may not be complete.



Catalyst Semiconductor, Inc.
Corporate Headquarters
2975 Stender Way
Santa Clara, CA 95054
Phone: 408.542.1000
Fax: 408.542.1200
www.catsemi.com

Document No: MD-2128
Revision: A
Issue date: 03/19/08