

DESCRIPTION

The AMC79L05 is a 3-terminal fixed negative-voltage designed for a wide range of applications. This regulator can provide local on card regulation, eliminating the distribution problems associated with single point regulation. In addition, it can be used with power-pass elements to make high-current voltage regulators with 100mA output current.

Protection features such as thermal shutdown and current limiting have been designed internally which will protect the device from damage in case of overload or overheating.

FEATURES

- **±5% tolerance of output voltage**
- **Wide input range**
- **Internal thermal overload protection**
- **Output current $\geq 100\text{mA}$**
- **No External Components**
- **Short circuit protection**
- **Available in 3L plastic TO-92 and plastic 8 pin S.O.I.C.**
- **Identical pin assignment to earlier 79L05 series.**

APPLICATIONS

- Logic Systems
- Computer Add-On Cards
- Modem Cards
- Power Suppliers

PACKAGE PIN OUT

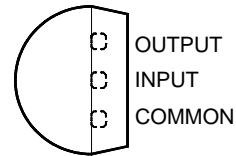

**3-Pin Plastic TO-92
(Top View)**

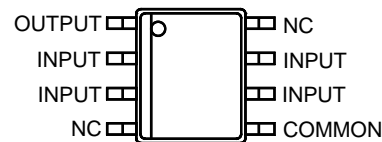

**8-Pin S.O.I.C
Surface Mount
(Top View)**

ORDER INFORMATION

| T_A (°C) | LP | Plastic TO-92 3-pin | DM | Plastic SO-8 8-pin |
|------------|-----------------------|------------------------|-----------------------|-----------------------|
| | 0 to 70 | AMC79L05LP | | AMC79L05DM |
| 0 to 70 | AMC79L05LP(Lead Free) | | AMC79L05DM(Lead Free) | |

Note: 1.All surface-mount and TO-92 packages are available in Tape & Reel. Append the letter "T" to part number (i.e. AMC79L05LPT or AMC79L05DMT).
2.For TO-92 in Tape & Box (without reel), add suffix "TB" (i.e. AMC79L05LPTB).
3.The letter "F" is marked for Lead Free process.

ABSOLUTE MAXIMUM RATINGS (Note 1)

| | |
|--|----------------|
| Input Voltage | -30V |
| Operating free-air temperature range, T_A | 0°C to 70°C |
| Storage temperature range | -65°C to 150°C |
| Lead temperature (soldering, 10 seconds) | 260°C |
| Note 1: Exceeding these ratings could cause damage to the device. All voltages are with respect to Ground. Currents are positive into, negative out of the specified terminal. | |

THERMAL DATA

| | |
|--|----------|
| LP PACKAGE: | |
| Thermal Resistance-Junction to Ambient, θ_{JA} | 156 °C/W |
| DM PACKAGE: | |
| Thermal Resistance-Junction to Ambient, θ_{JA} | 165 °C/W |
| Junction Temperature Calculation: $T_J = T_A + (P_D \times \theta_{JA})$. The θ_{JA} numbers are guidelines for the thermal performance of the device/pc-board system. All of the above assume no ambient airflow. | |

RECOMMENDED OPERATING CONDITIONS

| Parameter | Symbol | Recommended Operating Conditions | | | Units |
|--|-----------|----------------------------------|------|------|-------|
| | | Min. | Typ. | Max. | |
| Input Voltage | V_I | -7 | | -20 | V |
| Output Current | I_{OUT} | | | 100 | mA |
| Operating Virtual Junction Temperature | T_J | 0 | | 125 | °C |

ELECTRICAL CHARACTERISTICS

Unless otherwise specified, these specifications in **bold type** apply over the operating temperature range of $0^{\circ}\text{C} \leq T_J \leq +150^{\circ}\text{C}$, $V_{IN} = -10\text{V}$, $I_{OUT} = 40\text{mA}$, $C_{IN} = 0.33\mu\text{F}$, $C_{OUT} = 0.1\mu\text{F}$, and are for DC characteristics only. (Low duty cycle pulse testing techniques are used which maintains junction and case temperatures equal to the ambient temperature.)

| Parameter | Symbol | Test Conditions | AMC79L05 | | | Units |
|---------------------------------|-----------------|---|--------------|------|--------------|---------------|
| | | | Min. | Typ. | Max. | |
| Output Voltage | V_{OUT} | $T_J = 25^{\circ}\text{C}$ | -4.8 | -5.0 | -5.2 | V |
| | | $-7\text{V} \leq V_{IN} \leq -20\text{V}$, $1\text{mA} \leq I_{OUT} \leq 40\text{mA}$ | -4.75 | | -5.25 | |
| | | $1\text{mA} \leq I_{OUT} \leq 70\text{mA}$ | -4.75 | | -5.25 | |
| Line Regulation | ΔV_{OI} | $-7\text{V} \leq V_{IN} \leq -20\text{V}$, $T_J = 25^{\circ}\text{C}$ | | 15 | 150 | mV |
| | | $-8\text{V} \leq V_{IN} \leq -20\text{V}$, $T_J = 25^{\circ}\text{C}$ | | | 100 | |
| Load Regulation | ΔV_{OL} | $1\text{mA} \leq I_{OUT} \leq 100\text{mA}$, $T_J = 25^{\circ}\text{C}$ | | 20 | 60 | mV |
| | | $1\text{mA} \leq I_{OUT} \leq 40\text{mA}$, $T_J = 25^{\circ}\text{C}$ | | 10 | 30 | |
| Peak Output Current | I_{PEAK} | $T_J = 25^{\circ}\text{C}$ | | 140 | | mA |
| Dropout Voltage | | $T_J = 25^{\circ}\text{C}$ | | 1.7 | | V |
| Quiescent Current | I_Q | $T_J = 25^{\circ}\text{C}$ | | | 6.6 | mA |
| | | $T_J = 125^{\circ}\text{C}$ | | | 6.0 | |
| Quiescent Current Change | ΔI_Q | $-8\text{V} \leq V_{IN} \leq -20\text{V}$ | | | 1.5 | mA |
| | | $1\text{mA} \leq I_{OUT} \leq 40\text{mA}$ | | | 0.1 | |
| Ripple Rejection (note 2) | R_R | $f = 120\text{Hz}$, $-8\text{V} \leq V_{IN} \leq -18\text{V}$, $T_J = 25^{\circ}\text{C}$ | 41 | 49 | | dB |
| Output Noise Voltage (note 2) | V_{ORMS} | $10\text{Hz} \leq f \leq 100\text{KHz}$, $T_J = 25^{\circ}\text{C}$ | | 40 | | μV |

Note 2: These parameters, although guaranteed, are not 100% tested in production prior to shipment

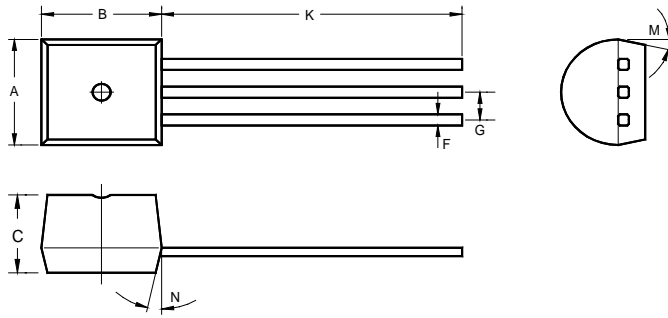
PACKAGE
3-Pin Plastic TO-92

Note: For TO-92 in tape & reel, refer to TO-92 package and carrier dimension data for lead dimensions.

| | INCHES | | | MILLIMETERS | | |
|---|--------|-------|-------|-------------|-------|------|
| | MIN | TYP | MAX | MIN | TYP | MAX |
| A | 0.175 | 0.180 | 0.205 | 4.45 | 4.57 | 5.21 |
| B | 0.170 | 0.180 | 0.210 | 4.32 | 4.57 | 5.33 |
| C | 0.125 | 0.142 | 0.165 | 3.18 | 3.62 | 4.19 |
| F | - | 0.015 | - | - | 0.38 | - |
| G | - | 0.050 | - | - | 1.27 | - |
| J | - | 0.150 | - | - | 3.81 | - |
| K | 0.500 | 0.580 | - | 12.70 | 14.73 | - |
| M | - | 5° | - | - | 5° | - |
| N | - | 5° | - | - | 5° | - |

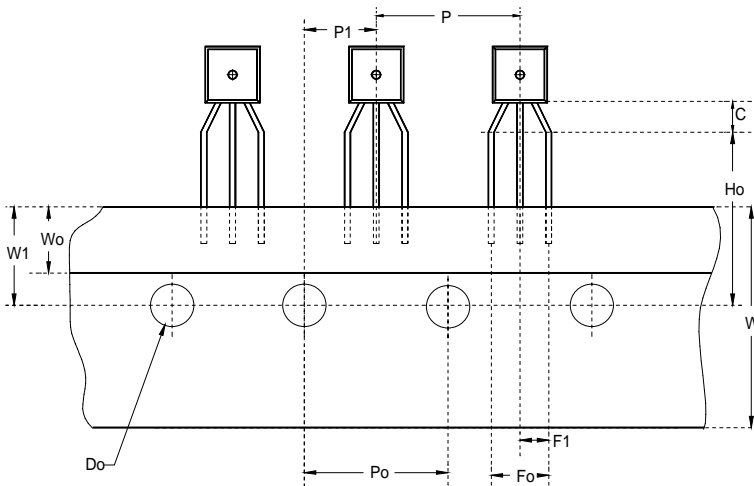
3-Pin Plastic TO-92 Package (Taped and Reeled) and Carrier Dimensions

Note: For 3L TO92, 2,000 units per Reel

| | INCHES | | | MILLIMETERS | | |
|----|--------|-------|-------|-------------|------|------|
| | MIN | TYP | MAX | MIN | TYP | MAX |
| C | 0.079 | - | - | 2.00 | - | - |
| P | 0.480 | 0.500 | 0.520 | 12.2 | 12.7 | 13.2 |
| Po | 0.488 | 0.500 | 0.512 | 12.4 | 12.7 | 13.0 |
| Do | 0.150 | 0.157 | 0.165 | 3.8 | 4.0 | 4.2 |
| P1 | 0.230 | 0.250 | 0.256 | 5.85 | 6.35 | 6.85 |
| Fo | 0.165 | 0.197 | 0.220 | 4.2 | 5.0 | 5.6 |
| W | 0.669 | 0.709 | 0.748 | 17.0 | 18.0 | 19.0 |
| Ho | 0.610 | 0.630 | 0.649 | 15.5 | 16.0 | 16.5 |
| W0 | 0.224 | 0.236 | 0.248 | 5.7 | 6.0 | 6.3 |
| W1 | 0.335 | 0.354 | 0.374 | 8.5 | 9.0 | 9.5 |

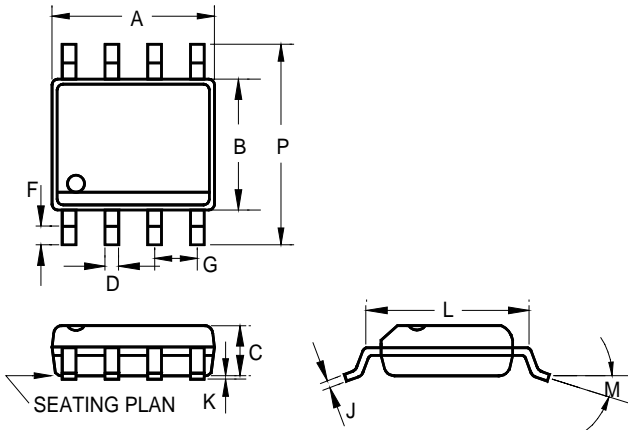
8-Pin Plastic S.O.I.C.

Note: For 8 pin S.O.I.C., 100 units per tube

| | INCHES | | | MILLIMETERS | | |
|---|-----------|-----|-------|-------------|-----|------|
| | MIN | TYP | MAX | MIN | TYP | MAX |
| A | 0.183 | - | 0.202 | 4.65 | - | 5.13 |
| B | 0.144 | - | 0.163 | 3.66 | - | 4.14 |
| C | 0.068 | - | 0.074 | 1.73 | - | 1.88 |
| D | 0.010 | - | 0.020 | 0.25 | - | 0.51 |
| F | 0.015 | - | 0.035 | 0.38 | - | 0.89 |
| G | 0.050 BSC | | | 1.27 BSC | | |
| J | 0.007 | - | 0.010 | 0.19 | - | 0.25 |
| K | 0.005 | - | 0.010 | 0.13 | - | 0.25 |
| L | 0.189 | - | 0.205 | 4.80 | - | 5.21 |
| M | - | - | 8° | - | - | 8° |
| P | 0.228 | - | 0.244 | 5.79 | - | 6.20 |

IMPORTANT NOTICE

ADDtek reserves the right to make changes to its products or to discontinue any integrated circuit product or service without notice, and advises its customers to obtain the latest version of relevant information to verify, before placing orders, that the information being relied on is current.

A few applications using integrated circuit products may involve potential risks of death, personal injury, or severe property or environmental damage. ADDtek integrated circuit products are not designed, intended, authorized, or warranted to be suitable for use in life-support applications, devices or systems or other critical applications. Use of ADDtek products in such applications is understood to be fully at the risk of the customer. In order to minimize risks associated with the customer's applications, the customer should provide adequate design and operating safeguards.

ADDtek assumes no liability to customer product design or application support. ADDtek warrants the performance of its products to the specifications applicable at the time of sale.

ADDtek Corp.

9F, No. 20, Sec. 3, Bade Rd., Taipei, Taiwan, 105

TEL: 2-25700299

FAX: 2-25700196
