

SSAC100

Solid State AC Controller(Anti-Parallel Thyristor-Thyristor Modules)

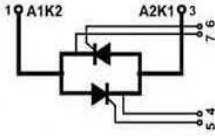
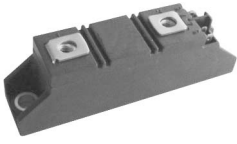

| Type | V_{RSM} | V_{RRM} |
|-------------|-----------|-----------|
| | V_{DSM} | V_{DRM} |
| | V | V |
| SSAC100GK08 | 900 | 800 |
| SSAC100GK12 | 1300 | 1200 |
| SSAC100GK14 | 1500 | 1400 |
| SSAC100GK16 | 1700 | 1600 |
| SSAC100GK18 | 1900 | 1800 |
| SSAC100GK20 | 2100 | 2000 |
| SSAC100GK22 | 2300 | 2200 |

Dimensions in mm (1mm=0.0394")

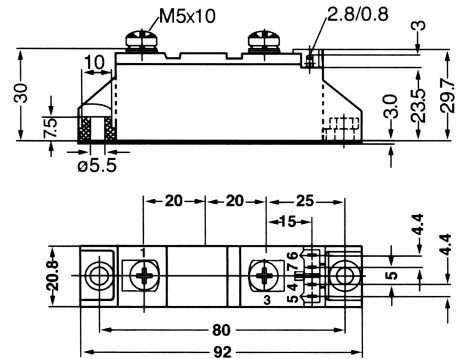

| Symbol | Test Conditions | Maximum Ratings | Unit | |
|------------------------------------|--|---|------------------|------------|
| I_{TRMS} , I_{FRMS} | $T_{VJ}=T_{VJM}$ | 180 | A | |
| I_{TAVM} , I_{FAVM} | $T_C=85^{\circ}C$; 180° sine | 100 | | |
| I_{TSM} , I_{FSM} | $T_{VJ}=45^{\circ}C$ $V_R=0$ | t=10ms (50Hz), sine t=8.3ms (60Hz), sine | A | |
| | $T_{VJ}=T_{VJM}$ $V_R=0$ | t=10ms(50Hz), sine t=8.3ms(60Hz), sine | | |
| $\int i^2 dt$ | $T_{VJ}=45^{\circ}C$ $V_R=0$ | t=10ms (50Hz), sine t=8.3ms (60Hz), sine | A ² s | |
| | $T_{VJ}=T_{VJM}$ $V_R=0$ | t=10ms(50Hz), sine t=8.3ms(60Hz), sine | | |
| $(di/dt)_{cr}$ | $T_{VJ}=T_{VJM}$ f=50Hz, $t_p=200\mu s$ $V_D=2/3V_{DRM}$ $I_G=0.45A$ $di/dt=0.45A/\mu s$ | repetitive, $I_T=250A$ | 150 | A/ μs |
| | | non repetitive, $I_T=I_{TAVM}$ | 500 | |
| $(dv/dt)_{cr}$ | $T_{VJ}=T_{VJM}$; $R_{GK}=\infty$; method 1 (linear voltage rise) | $V_{DR}=2/3V_{DRM}$ | 1000 | V/ μs |
| P_{GM} | $T_{VJ}=T_{VJM}$ $I_T=I_{TAVM}$ | $t_p=30\mu s$ | 10 | W |
| | | $t_p=300\mu s$ | 5 | |
| P_{GAV} | | | 0.5 | W |
| V_{RGM} | | | 10 | V |
| T_{VJ} T_{VJM} T_{stg} | | | -40...+125 | °C |
| | | | 125 | |
| | | | -40...+125 | |
| V_{ISOL} | 50/60Hz, RMS $I_{ISOL}\leq 1mA$ | t=1min | 3000 | V~ |
| | | t=1s | 3600 | |
| M_d | Mounting torque (M5) | | 2.5-4.0/22-35 | Nm/lb.in. |
| | Terminal connection torque (M5) | | 2.5-4.0/22-35 | |
| Weight | Typical including screws | | 90 | g |

SSAC100

Solid State AC Controller(Anti-Parallel Thyristor-Thyristor Modules)

| Symbol | Test Conditions | Characteristic Values | Unit |
|--------------------|---|-----------------------|-----------|
| I_{RRM}, I_{DRM} | $T_{VJ}=T_{VJM}; V_R=V_{RRM}; V_D=V_{DRM}$ | 15 | mA |
| V_T, V_F | $I_T, I_F=300A; T_{VJ}=25^{\circ}C$ | 1.74 | V |
| V_{TO} | For power-loss calculations only ($T_{VJ}=T_{VJM}$) | 0.85 | V |
| r_T | | 3.2 | $m\Omega$ |
| V_{GT} | $V_D=6V;$ $T_{VJ}=25^{\circ}C$ $T_{VJ}=-40^{\circ}C$ | 1.5 1.6 | V |
| I_{GT} | $V_D=6V;$ $T_{VJ}=25^{\circ}C$ $T_{VJ}=-40^{\circ}C$ | 100 200 | mA |
| V_{GD} | $T_{VJ}=T_{VJM};$ $V_D=2/3V_{DRM}$ | 0.25 | V |
| I_{GD} | $T_{VJ}=T_{VJM};$ $V_D=2/3V_{DRM}$ | 10 | mA |
| I_L | $T_{VJ}=25^{\circ}C; t_p=30\mu s; V_D=6V$ $I_G=0.45A; di_G/dt=0.45A/\mu s$ | 200 | mA |
| I_H | $T_{VJ}=25^{\circ}C; V_D=6V; R_{GK}=\infty$ | 150 | mA |
| t_{gd} | $T_{VJ}=25^{\circ}C; V_D=1/2V_{DRM}$ $I_G=0.45A; di_G/dt=0.45A/\mu s$ | 2 | μs |
| t_q | $T_{VJ}=T_{VJM}; I_T=150A; t_p=200\mu s; -di/dt=10A/\mu s$ $V_R=100V; dv/dt=20V/\mu s; V_D=2/3V_{DRM}$ | 185 | μs |
| Q_S | $T_{VJ}=T_{VJM}; I_T, I_F=50A; -di/dt=6A/\mu s$ | 170 | μC |
| I_{RM} | | 45 | A |
| R_{thJC} | per thyristor/diode; DC current per module | 0.22 0.11 | K/W |
| R_{thJK} | per thyristor/diode; DC current per module | 0.42 0.21 | K/W |
| d_s | Creeping distance on surface | 12.7 | mm |
| d_A | Creepage distance in air | 9.6 | mm |
| a | Maximum allowable acceleration | 50 | m/s^2 |

FEATURES

- * International standard package
- * Copper Base Plate with Inter-DCB
- * Planar passivated chips
- * Isolation voltage 3600 V~

APPLICATIONS

- * DC motor control
- * Softstart AC motor controller
- * Light, heat and temperature control

ADVANTAGES

- * Space and weight savings
- * Simple mounting with two screws
- * Improved temperature and power cycling
- * Reduced protection circuits

SSAC100

Solid State AC Controller (Anti-Parallel Thyristor-Thyristor Modules)

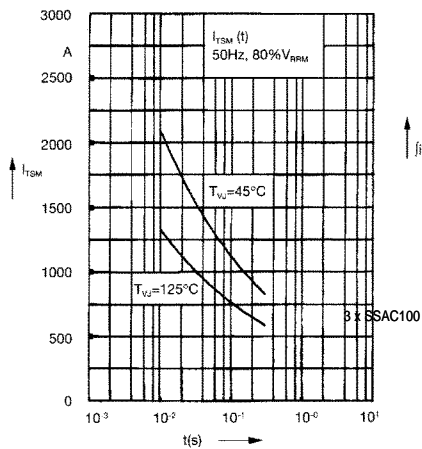

Fig. 1 Surge overload current
 I_{TSM} , I_{FSM} : Crest value, t : duration

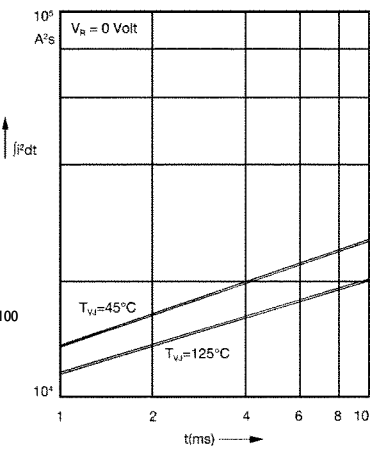

Fig. 2 $\int i^2 dt$ versus time (1-10 ms)

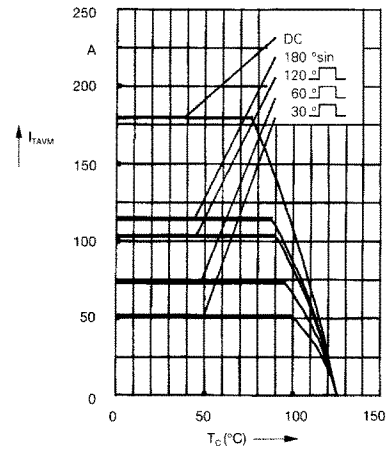

Fig. 2a Maximum forward current at case temperature

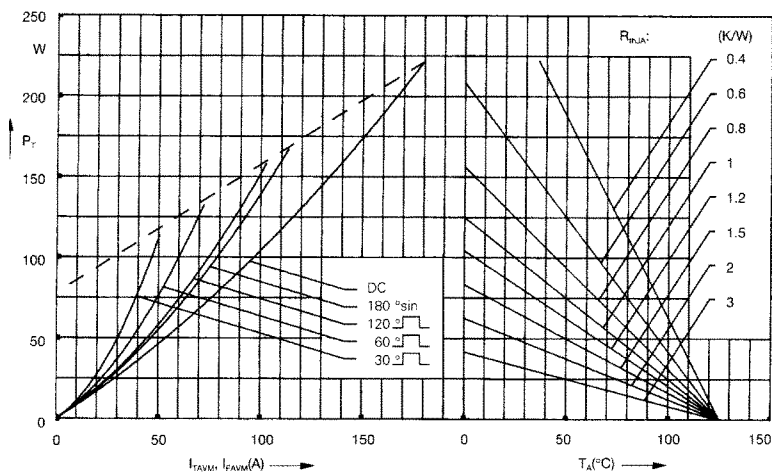

Fig. 3 Power dissipation versus on-state current and ambient temperature (per thyristor or diode)

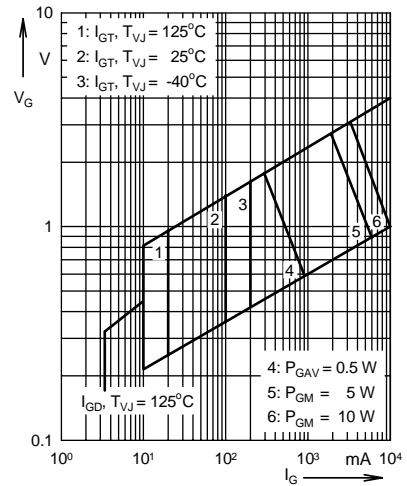

Fig. 4 Gate trigger characteristics

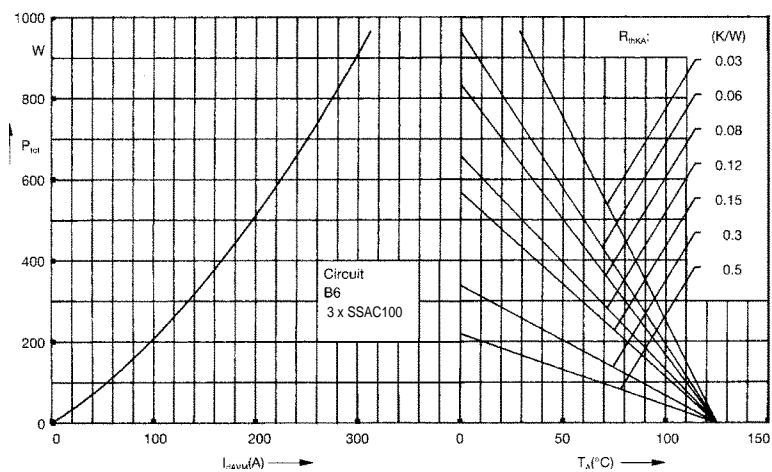

Fig. 5 Three phase rectifier bridge: Power dissipation versus direct output current and ambient temperature

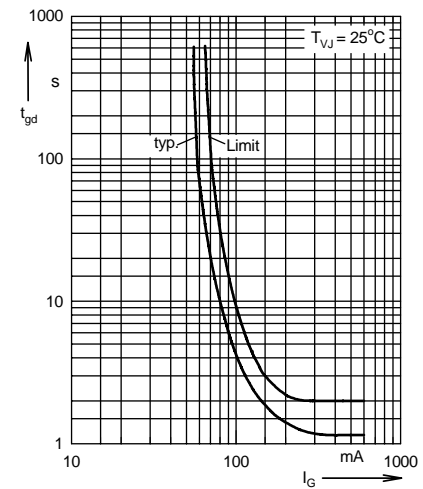

Fig. 6 Gate trigger delay time

SSAC100

Solid State AC Controller(Anti-Parallel Thyristor-Thyristor Modules)

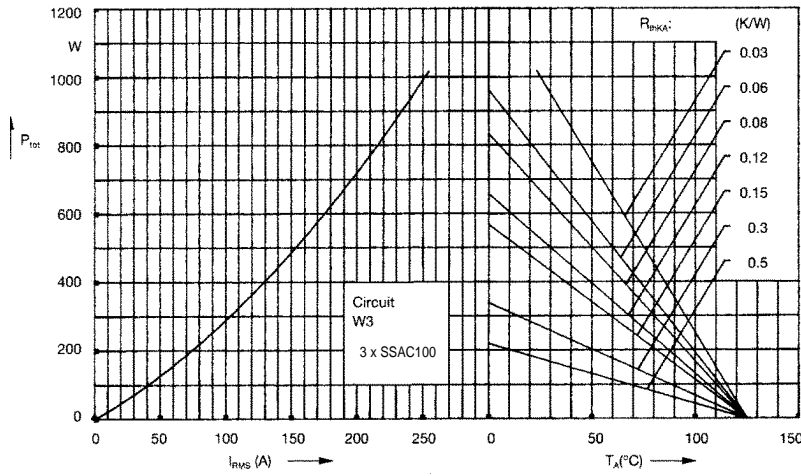

Fig. 7 Three phase AC-controller: Power dissipation versus RMS output current and ambient temperature

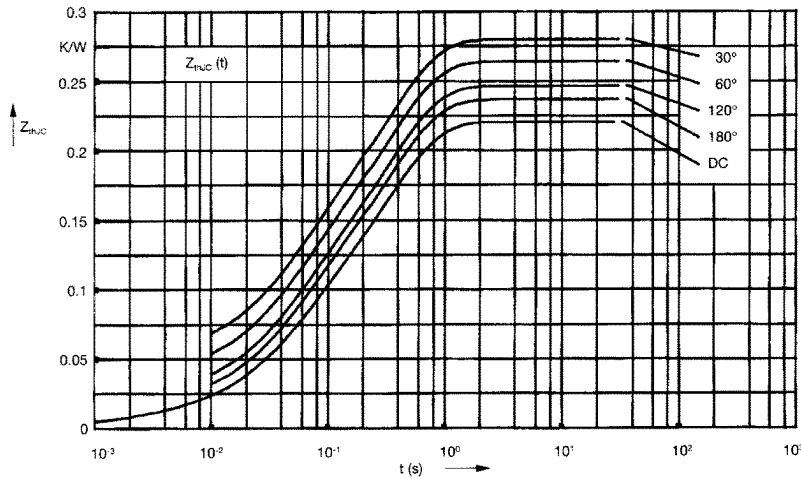

Fig. 8 Transient thermal impedance junction to case (per thyristor or diode)

R_{thJC} for various conduction angles d:

| d | R_{thJC} (K/W) |
|-------|------------------|
| DC | 0.22 |
| 180°C | 0.23 |
| 120°C | 0.25 |
| 60°C | 0.27 |
| 30°C | 0.28 |

Constants for Z_{thJC} calculation:

| i | R_{thi} (K/W) | t_i (s) |
|---|-----------------|-----------|
| 1 | 0.0066 | 0.0019 |
| 2 | 0.0678 | 0.0477 |
| 3 | 0.1456 | 0.344 |

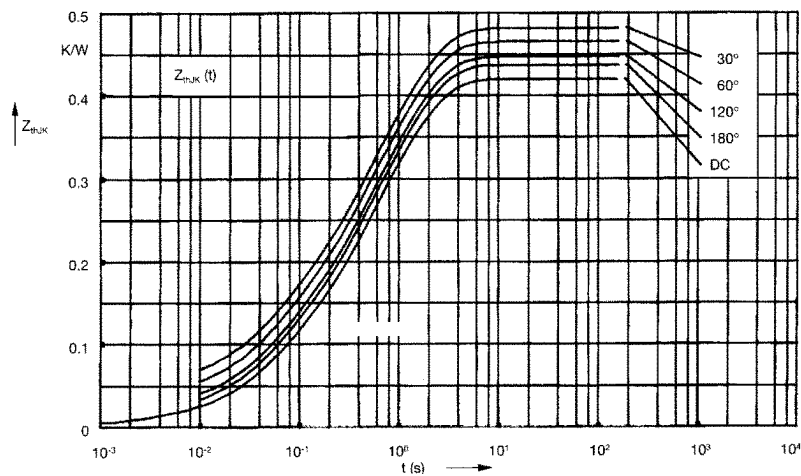

Fig. 9 Transient thermal impedance junction to heatsink (per thyristor or diode)

R_{thJK} for various conduction angles d:

| d | R_{thJK} (K/W) |
|-------|------------------|
| DC | 0.42 |
| 180°C | 0.43 |
| 120°C | 0.45 |
| 60°C | 0.47 |
| 30°C | 0.48 |

Constants for Z_{thJK} calculation:

| i | R_{thi} (K/W) | t_i (s) |
|---|-----------------|-----------|
| 1 | 0.0066 | 0.0019 |
| 2 | 0.0678 | 0.0477 |
| 3 | 0.1456 | 0.344 |
| 4 | 0.2 | 1.32 |